

16 POTENTIOMETRIC METHODS

CONTAINS :

- 16.1 Introduction
- 16.2 Theory
 - 16.2.1 General considerations
 - 16.2.2 End-point determination
- 16.3 Instrumentation
 - 16.3.1 Electrodes
 - 16.3.2 Automatic titrator (Preset end-point titrator)
- 16.4 Applications of potentiometric titrations in pharmaceutical analysis
 - 16.4.1 Cognate assays

16.1. INTRODUCTION

Generally speaking the actual concentration of a broad spectrum of solutes may be measured conveniently by forming an appropriate electrochemical cell. Thus, most electrochemical cells invariably comprise of *two* electrodes, namely : (a) an *Indicator Electrode*—the voltage of which solely depends on the thermodynamic activity (*i.e.*, concentration) of one specific component in the solution ; and (b) a *Reference Electrode*—the voltage of which must be absolutely independent of the nature and composition of the solutions wherein it is immersed. Placing together of these two electrodes in a solution obviously gives rise to an electrochemical cell ; and consequently the voltage thus generated across the electrodes may be determined by connecting it either to a potentiometer or a millivoltmeter that has a sensitivity to measure ± 0.2 mV, besides possessing a high impedance-input of minimum 10^{12} ohms (Ω).

Under these experimental parameters when an extremely feeble current, of the order of less than 5 pA, is drawn from the electrodes, the e.m.f. of the cell may be expressed as below :

$$E_{\text{cell}} = E_{+} - E_{-} + E_j \quad \dots(a)$$

where, E_j = e.m.f. at the liquid junction.

In Eq. (a), E_j may be eliminated completely by employing a saltbridge integral with the reference electrode. In usual practice, the loss of electrons or reduction occurs from the prevailing chemical system at the cathode ; whereas the gain of electrons or oxidation takes place at the anode.

16.2. THEORY

In a situation, where a metal M is placed in a solution containing its own ions M^{n+} , an electrode potential is established across the two electrodes, whose actual value is provided by the Nernst equation as shown below :

$$E = E^{\circ} + (RT/nF) \ln a M^{n+} \quad \dots (b)$$

From Eq. (b) the relationship to a cationic electrode, *i.e.*, sensitive only to a cation concentration, may be expressed as :

$$E = E^- Y^{n+}, Y + (RT/nF) \log aY^{n+} \quad \dots(c)$$

to an anionic electrode :

$$E = E^- X^{n-}, X - (RT/nF) \log a X^{n-} \quad \dots(d)$$

or to a redox electrode :

$$E = E^-_{\text{ox, red}} + (RT/nF) \log \frac{a_{\text{ox}}}{a_{\text{red}}} \quad \dots(e)$$

where, E^- = Standard electrode potential (SEP)

(or reduction potential of the half-cell involved),

a = Thermodynamic activity of the ion to which the electrode is sensitive,

R = Gas constant ($8.314 \text{ JK}^{-1} \text{ mol}^{-1}$),

T = Absolute temperature (K),

F = Faraday (96500 C/mole of electrons), and

n = Number of electrons involved in the electrode reaction.

Direct Potentiometry : The procedure adopted of employing a single measurement of electrode potential to determine the concentration of an ionic species in a solution is usually termed as **direct potentiometry**.

Disadvantages : Direct potentiometry has the following *two* serious disadvantages namely :

(a) **From the Nernst Eq. (b) :** Considering $n = 1$, temperature 25°C , RT/nF being a constant, and introducing the factor for the conversion of natural logarithms to logarithms to base 10, the term RT/nF shows a value of 0.0591 V. Therefore, for an ion M^+ (monovalent) a ten-time change in the electrode potential E by approximately 60 millivolts (mV) ; whereas for an ion M^{2+} (bivalent) a change in identical magnitude of activity shall bring forth alternation of E by about 30 mV. Hence, it is evident that to attain a desired accuracy and precision to the extent of 1% in the estimated value for the direct concentration using the technique of direct potentiometry, for M^+ ion—the E should be measurable correctly within 0.26 mV ; and for M^{2+} ion—within 0.1 mV.

(b) **Uncertainty due to liquid-junction potential (E_j) :** It has been observed that the liquid-junction potential (E_j) occurring between the two solutions, one related to the reference-electrode and the other to the indicator-electrode gives rise to a certain quantum of uncertainty with regard to e.m.f. measurement.

Remedial Measures : There are *two* ways to eliminate the above anomaly, namely :

(i) to replace the reference electrode with a concentration-cell *i.e.*, with an electrode comprised of a rod of the same metal as that employed in the indicator electrode plus a solution having the same cation as present in the test-solution, but with a known concentration. Thus, the ionic activity of the metal ion present in the test-solution may be represented by the following expression :

$$E_{\text{cell}} = (RT/nF) \log \frac{(\text{activity})_{\text{known}}}{(\text{activity})_{\text{unknown}}} \quad \dots(f)$$

(ii) by using one solution which contains a high concentration of KCl or NH_4NO_3 *i.e.*, such electrolytes that offer almost identical values for ionic conductivities for both cation as well as anion.

Keeping in view the above serious anomalies commonly encountered with direct potentiometry, such as : an element of uncertainty triggered by liquid junction potential (E_j) and high degree of sensitivity required to measure electrode potential (E), it promptly gave birth to the phenomenon of potentiometric titrations,

which subsequently received a high level of sophistication and ultimately turned into a versatile analytical method. As the name suggests, it is indeed a titrimetric method whereby a series of potentiometric measurements are recorded so as to locate the end-point as correctly as possible. In this procedure, it is particularly of more interest to know the exact changes in the observed electrode potential after each addition of the titrant, rather than a precise and accurate electrode potential often brought about by a given solution. Thus, in a way the impact due to liquid-junction-potential (E_j) has been eliminated completely. It is pertinent to mention here that in a potentiometric titration procedure the apparent change in cell e.m.f. takes place not only most rapidly but also most distinctly in the vicinity of the end-point.

16.2.1. GENERAL CONSIDERATIONS

The potentiometric titrations invariably cover a broad-spectrum of chemical reactions that may be classified as follows :

- (i) Neutralization reactions,
- (ii) Redox reactions,
- (iii) Precipitation reactions,
- (iv) Complexation reactions, and
- (v) Potentiometric titrations in non-aqueous solvents.

The general principles which govern the above different types of reactions will be discussed briefly in the sections that follow :

16.2.1.1. Neutralization Reactions

The accuracy and precision with which the end-point can be determined potentiometrically solely depends upon the quantum of change in the observed e.m.f. in the vicinity of the equivalence point, which in turn entirely depends upon the strength and the concentration of acid and base employed.

Merits of the Method : It is found to be useful to titrate a mixture of acids having a significant difference in their strengths, for instance : HCl and CH_3COOH (alcoholic). In this case, the first-break in the titration curve signifies that the stronger of the two acids *i.e.*, HCl, gets neutralized ; whereas, the second-break represents the entire completion (*i.e.*, HCl + CH_3COOH).

In order to get fruitful and reproducible results it is quite necessary that the strengths between either the two acids or bases in question must vary by at least 10^5 to 1.

Demerits of the Method : The neutralization reactions often found to be giving unsatisfactory results in the following *two* instances. They are :

- (a) when both the acid and the base are appreciably weak, and
- (b) when either the acid or the base is very weak (*i.e.*, $K < 10^{-8}$) and also the prevailing solutions are dilute.

Note : In (a) above, an accuracy upto 1% is achievable in 0.1 M solution.

Choice of Electrodes :

Indicator Electrodes : Hydrogen, Glass or Antimony electrodes ;

Reference Electrode : Calomel electrode.

16.2.1.2. Redox Reactions

In this particular case the ratio of the concentrations of the oxidized and reduced forms of ionic species establishes the determining factor. Considering the following reaction,



The electrode potential E is given by the following expression :

$$E = E^- + \frac{0.0591}{n} \log \frac{[\text{Ox}]}{[\text{Red}]} \quad \dots (g)$$

where, E^- = Standard potential of the system.

In other words, the potential of the immersed indicator electrode is solely controlled and monitored by the ratio of the ionic concentrations in Eq. (g). Furthermore, in the course of either reduction of an oxidizing agent or *vice-versa i.e.* the said ratio, and hence the observed potential, undergoes an instant rapid change in the proximity of the end-point of the redox reaction.

Example : A typical example is that of titrations of Fe^{2+} with potassium permanganate or potassium dichromate or cerium (IV) sulphate.

Choice of Electrode : Indicator Electrode : Pt wire or foil.

The oxidizing agent is usually taken in the burette.

16.2.1.3. Precipitation Reactions

In this the determining factor mainly rests on the solubility product of the resulting nearly insoluble material generated in the course of a precipitation reaction and its ionic concentration at the equivalence point. It is, however, pertinent to mention here that the indicator electrode must readily come into equilibrium with one of the ions.

Example : Titration of Ag^+ with a halide (Cl^- , Br^- or I^-) or with SCN^- (thiocyanate ion).

Choice of Electrodes :

Reference Electrodes : Saturated Calomel Electrode (SCE) :

Silver-silver chloride Electrode ;

Indicator Electrodes : Silver wire or Platinum wire or gauze plated with silver and sealed into a glass-tube.

(It should readily come into equilibrium with one of the ions of the precipitate).

Salt-Bridge : For the determination of a halide the salt-bridge should be a saturated solution of potassium nitrate.

Note : Ion-selective electrode can also be employed.

16.2.1.4. Complexation Reaction

Complexation invariably occurs by the interaction of a sparingly soluble precipitate with an excess amount of the reagent, for instance : the classical example of titration between KCN and AgNO_3 as expressed by the following reactions :

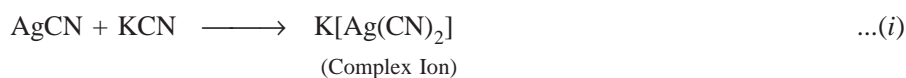

In Eq. (h) the precipitate of AgCN is produced at first instance ; consequently, the precipitate of AgCN initially produced gets dissolved by further addition of KCN to afford the complex ion $[\text{Ag}(\text{CN})_2]^-$ Eq. (i) and only a negligible quantum of Ag^+ ions remain in the solution. Thus, the entire process from *ab initio* to the final stage of titration may be divided into *three* distinct portions, namely :

(i) **Upto end-point :** Here, all the available CN^- ion has been virtually converted to the complex ion.

At this stage the ever increasing concentration reflects a gradually increasing concentration of Ag^+ ions, thereby slowly enhancing the potential of the Ag-electrode dipping in the solution,

(ii) **At the end-point :** It is usually visualized by a distinct and marked rise in potential, and

(iii) **Beyond end-point** : Further addition of AgNO_3 brings about only a gradual change in e.m.f. and AgCN gets precipitated. Ultimately, a second sudden change in potential may be visualized at this juncture when practically most of the CN^- ion gets precipitated as AgCN .

Choice of Electrodes :

Indicator Electrode : Silver electrode ;

Reference Electrodes : Calomel electrode ; Mercury-mercury (I) sulphate electrode.

Salt-Bridge : A saturated solution of KNO_3 or K_2SO_4 isolated from the reference electrode.

16.2.1.5. Potentiometric Titration in Non-Aqueous Solvents

The potentiometric technique has proved to be of great significance and utility for determining end-points of titrations in a non-aqueous media. The mV scale rather than the pH scale of the potentiometer must be used for obvious reasons, namely :

- (i) pH scale based upon buffers has no logical significance in a non-aqueous media, and
- (ii) the potentials in non-aqueous media may exceed the pH scale.

The resulting titration curves are more or less empirical and afford a reasonably dependable and reproducible means of end-point detection.

Choice of Electrodes :

Indicator Electrodes : Glass electrode ;

Reference Electrode : Calomel electrode ;

Salt-Bridge : A saturated solution of KCl.

16.2.2. END-POINT DETERMINATION

In fact, there are several acceptable means to graph the potentiometric titration data generated from an actual titration (Section : 16.2.1.1 to 16.2.1.5) in order to locate the exact (or nearest) end-point. These may be illustrated exclusively by employing the titration data provided in Table 16.1, between 25 ml of 0.01 M NaF and 0.01 M $\text{La}(\text{NO}_3)_3$.

**Table 16.1 : Data of Potentiometric Titration of 25.0 ml 0.01 M NaF
Against 0.01 M $\text{La}(\text{NO}_3)_3$**

Volume of $\text{La}(\text{NO}_3)_3$ (ml)	E (mV)	$\Delta E/\Delta V$ (mV ml ⁻¹)	$\Delta^2 E/\Delta V^2$ (mV ml ⁻²)
2.0	- 250	0.5	0.25
4.0	- 249	1	0
5.0	- 248	1	1
6.0	- 247	2	4
6.5	- 246	4	32
7.0	- 244	20	0
7.2	- 240	20	25
7.4	- 236	- 25	50
7.6	- 231	35	75
7.8	- 224	50	200
8.0	- 214	90	600
8.1	- 205	150	900
8.2	- 190	260	- 700
8.3	- 164	190	- 800

8.4	- 145	110	- 300
8.5	- 134	80	- 225
8.6	- 126	45	- 75
8.8	- 117	30	- 50
9.0	- 111	20	- 35
9.2	- 107	13	- 23
9.5	- 103	6	- 6
10.0	- 100	3	- 1
11.0	- 97	2	- 1
12.0	- 95	0.5	- 0.75

The simplest and the most commonly used method is to plot the cell voltage E , millivolts (mV), versus the volume (ml) of titrant added. Ultimately, the end-point is determined from the point of maximum slope of the curve *i.e.*, the point of inflexion, as depicted in Figure 16.1 (a). However, the degree of accuracy and precision with which this point of inflexion can be located from the plotted graph largely depends on the individual number of data points observed in the close proximities of the end-point.

Figure 16.1 (a) gives rise to a **sigmoid-curve** (or **S-shaped curve**) obtained either by using an appropriate equipment (automatic titrators) that plots the graph automatically* as the titration proceeds, or manually by plotting the raw experimental data. The central portion of the sigmoid curve, in fact is the critical zone where the point of inflexion resides and this may be located by adopting any one of the following *three* procedures, namely :

- (i) Method of parallel tangents,
- (ii) Method of bisection, and
- (iii) Method of circle fitting.

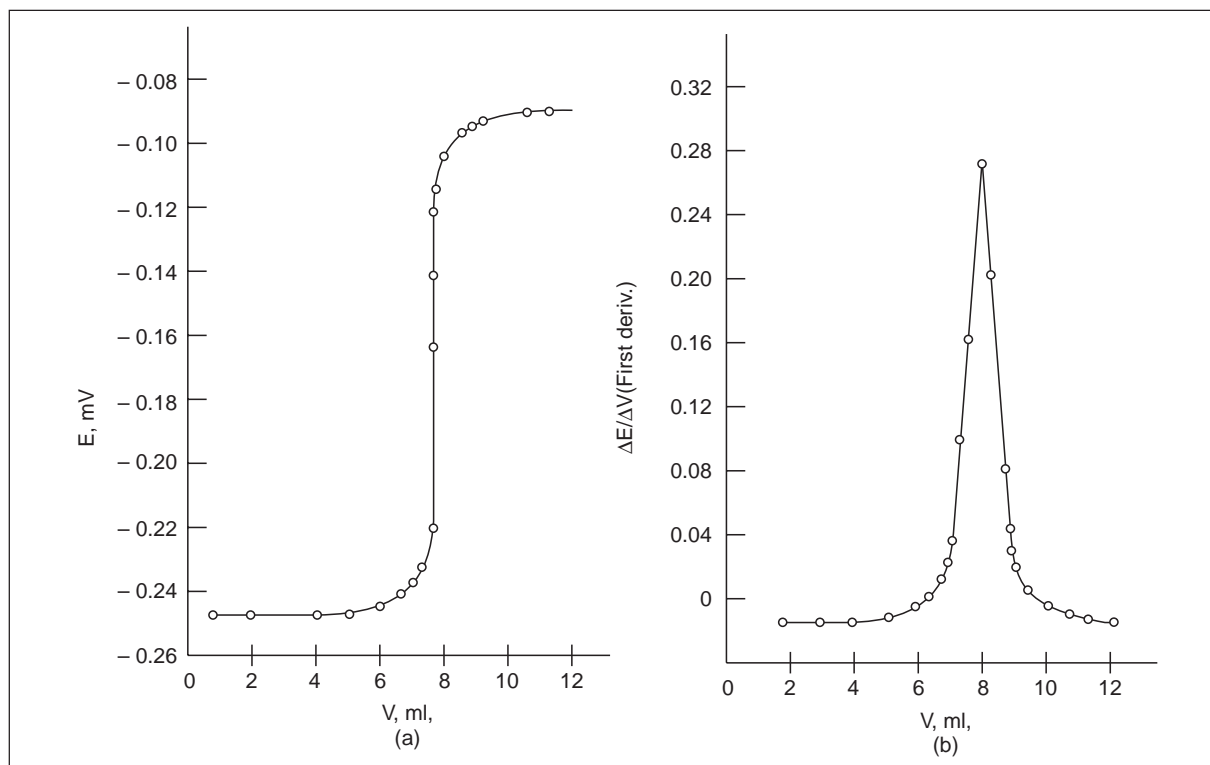

* Automatic titrators do not necessarily produce results that are more accurate than those obtained manually, but are much faster and capable of handling large samples.

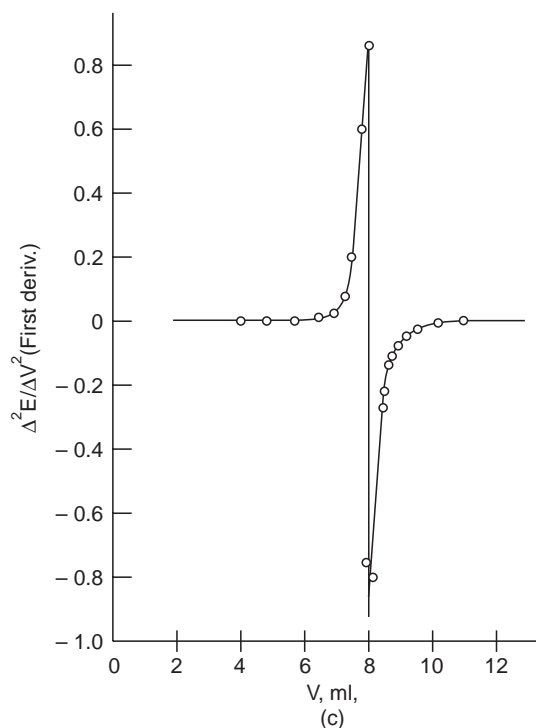

Figure 16.1 : Potentiometric Titration Curves of 25 ml of 0.01 M Sodium Fluoride Vs 0.01 M Lanthanum Nitrate ; (a) Sigmoid (Regular) Curve ; (b) First Derivative Curve ; (c) Second Derivative Curve.

Figure 16.1 (b) is obtained by plotting $\Delta E/\Delta V$ against V which is termed as the **first derivative curve**. It gives a maximum at the point of inflexion of the titration curve *i.e.*, at the end-point.

Figure 16.1 (c) is achieved by plotting the slope of the first derivative curve against the volume of titrant added *i.e.*, by plotting $\Delta^2 E/\Delta V^2$ Vs V and is known as the **second derivative curve**. Thus, the second derivative becomes zero at the point of inflexion and hence, affords a more exact measurement of the equivalence point.

The titration error (*i.e.*, difference between end-point and equivalence point) is found to be small when the potential change at the equivalence point is large. Invariably, in most of the reactions employed in potentiometric analysis, the titration error is normally quite small and hence may be neglected.

16.3. INSTRUMENTATION

Figure 16.2 illustrates a typical assembly for carrying out a potentiometric titration. Broadly speaking, the titration essentially comprises of measuring and subsequently recording a cell potential in terms of either mV or pH, after each sequentially known addition of reagents.

In usual practice, the titrant (*e.g.*, Lanthanum Nitrate) is added in large amounts at the initial stage ; as the end-point is approached, which is marked by distinct larger potential changes per addition, the subsequent increments are made smaller to the tune of 0.1 ml for each addition.

It is always advisable to allow sufficient time lapse after each addition of titrant so as to attain equilibrium. A gentle and uniform stirring by means of a magnetic stirrer also helps in hastening the ultimate achievement of equilibrium :

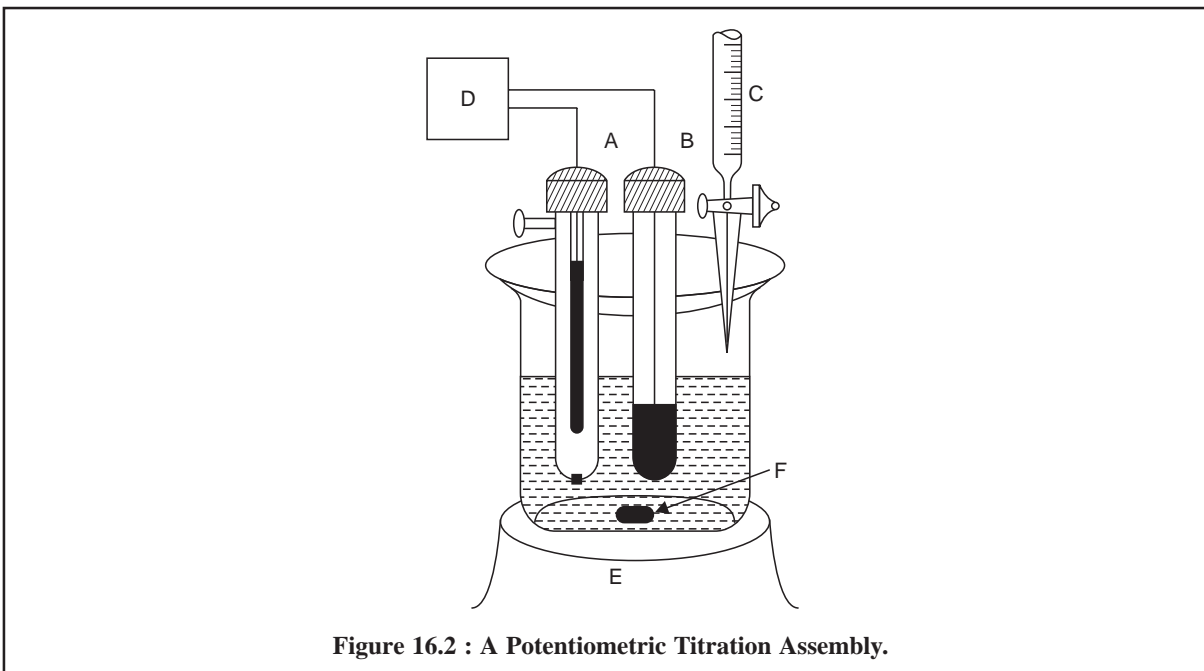

Figure 16.2 : A Potentiometric Titration Assembly.

The various components shown in Figure 16.2, are as follows :

- A = Saturated Calomel Electrode (SCE),
- B = Indicator Electrode,
- C = Burette to discharge titrant in the reacting vessel,
- D = pH Meter with a mV scale,
- E = Magnetic stirrer with variable speed, and
- F = Magnetic Guide.

16.3.1. ELECTRODES

The accurate, precise and effective potentiometric measurements are evidently made with the aid of the following *two* types of electrodes namely :

- (i) **Reference Electrodes**, such as :
 - (a) Standard Hydrogen Electrode,
 - (b) Saturated Calomel Electrode, and
 - (c) Silver-silver Chloride Electrode.
- (ii) **Indicator Electrodes**, such as :
 - (a) Metal Indicator Electrode, and
 - (b) Membrane Indicator Electrode.

These various kinds of electrodes will be discussed briefly, along with a diagrammatic representation wherever possible, in the sections that follow :

16.3.1.1. Reference Electrodes

In general, reference electrodes exhibit a potential which is absolutely independent of the solution wherein it is used. Besides, it must not display any significant change even when a small quantum of current is passed through it.

16.3.1.1.1. Standard Hydrogen Electrode (SHE)

The standard hydrogen electrode (SHE), as shown in Figure 16.3, is considered to be the universally accepted reference electrode. The metal electrode comprises of a small piece of platinum foil with a finely divided platinum, usually termed as **platinum black** because of its dark look. The coated foil is immersed in an acidic medium having a hydrogen ion activity of 0.1, and through which H_2 gas is bubbled at a partial pressure of 1.0 atm (unit activity). The Pt-black-foil possesses a relatively large-surface-area thereby enabling it to absorb an appreciable amount of H_2 gas, ultimately bringing it into direct contact with the surrounding H^+ ions at the electrode surface. Consequently, the Pt-electrode attains a potential which is finally estimated by the relative tendencies of H^+ ions to undergo reduction and H_2 (g) to undergo oxidation simultaneously. It is an usual convention to assign the potential of SHE a value exactly equal to zero at all temperatures.

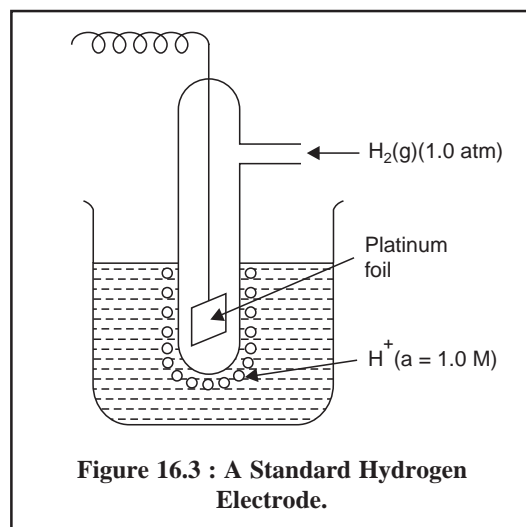

Figure 16.3 : A Standard Hydrogen Electrode.

16.3.1.1.2. Saturated Calomel Electrode

The schematic diagram of a commercial saturated calomel electrode (SCE) is depicted in Figure 16.4. It essentially consists of a platinum wire immersed in a slurry made up of pure mercury, solid mercurous chloride Hg_2Cl_2 (commonly known as **calomel**), and aqueous saturated solution of KCl, packed in the inner-tube (c) having a small hole (B). The outer-tube contains a saturated solution of KCl (D) having a porous ceramic fiber (A) at its lower end. It serves as a salt-bridge which allows the entire set-up immersed directly into the solution to be measured. The porous ceramic fiber permits establishment of electrical contact between one side of the salt-bridge and the solution under the examination and serves as a barrier between the said two solutions. The small opening at the top end of the salt-bridge tube serves as a fill-hole (E) through which either KCl solution may be filled or replaced as and when required. The different parts of the saturated calomel electrode are as follows :

- A = Porous ceramic fiber,
- B = Small-hole,
- C = Slurry of Hg, Hg_2Cl_2 and saturated KCl,
- D = Saturated KCl solution,
- E = Fill-hole, and
- F = Electrical lead.

The half-cell of SCE may be expressed as :



for which the half-reaction is :

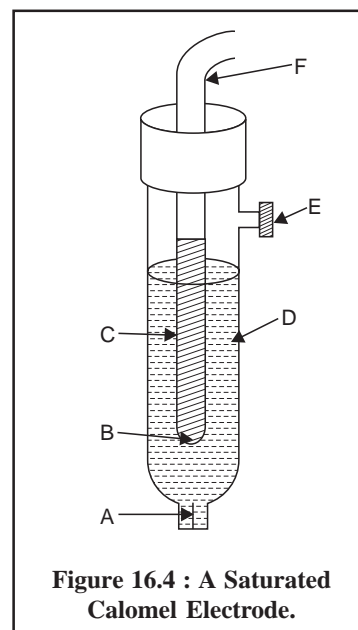
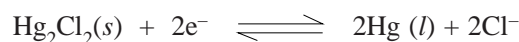

Figure 16.4 : A Saturated Calomel Electrode.

According to the Nernst equation, the potential of the electrode is represented by :

$$E = E^{\circ}_{\text{Hg}_2\text{Cl}_2/\text{Hg}} - \frac{0.0592}{2} \log \frac{(1) [\text{Cl}^-]^2}{1}$$

assuming the activities of Hg and Hg_2Cl_2 solid are both unity.

Advantages : The *two* major advantages of SCE are, namely :

- (a) Concentration of Cl^- does not alter appreciably even if some of the solvent gets evaporated, and
- (b) Generates a comparatively small junction potential (E_j) at the two salt-bridge solution interfaces.

16.3.1.1.3. Silver-silver Chloride Electrode

Figure 16.5 shows a silver-silver chloride electrode which comprises of a silver wire coated with silver chloride (B) and is duly placed in a 1 M KCl solution saturated with AgCl (C).

The half-cell of silver-silver chloride electrode may be represented as :

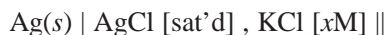

for which half-reaction would be :

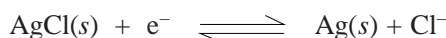

According to the Nernst equation, the potential of the electrode is expressed as :

$$E = E^{\circ}_{\text{AgCl}/\text{Ag}^+} - \frac{0.0592}{1} \log [\text{Cl}^-]$$

considering that the potential of the electrode is solely dependent on the concentration of Cl^- .

The various components of a silver-silver chloride electrode are, namely :

- A = Porous ceramic fiber,
- B = Ag wire coated with AgCl,
- C = 1 M KCl saturated with AgCl,
- D = Fill-hole, and
- E = Electrical lead.

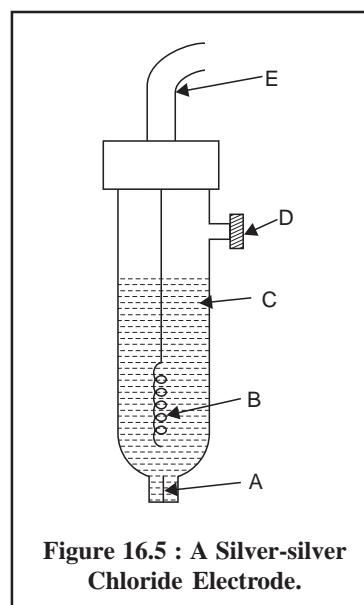

Figure 16.5 : A Silver-silver Chloride Electrode.

16.3.1.2. Indicator Electrodes

An indicator electrode is invariably used exclusively in conjunction with a reference electrode the response of which solely depends upon the concentration of the analyte.

16.3.1.2.1. Metal Indicator Electrode

Metal indicator electrodes develop a potential which is usually determined by the equilibrium position of a redox half-reaction at the electrode surface. These are further classified into the following *three* types, namely :

- (i) First order electrodes,
- (ii) Second order electrodes, and
- (iii) Inert electrodes.

which shall be discussed briefly below.

16.3.1.2.1.1. First-order electrodes

They are essentially comprised of a metal placed in a solution of its respective ions, for instance : a silver wire immersed into a AgNO_3 solution. Hence, the reversible half reaction may be represented as :

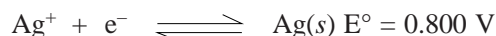

and the corresponding Nernst equation would be as follows :

$$E = 0.800 - \frac{0.0592}{1} \log \frac{1}{\text{Ag}^+}$$

The metals that display reversible half reactions with their respective ions and are found to be suitable for employing as first-order electrodes are Ag, Hg, Cu, Cd, Zn, Bi, Pb and Sn. However, several other metals like : Fe, Co, Cr and W are not useful due to the following reasons :

- (i) Non-reproducible potentials largely influenced by impurities,
- (ii) Irregular crystal structures in the solid-state, and
- (iii) Formation of oxide layers on their surfaces.

16.3.1.2.1.2. Second-order electrodes

Sometimes a metal electrode may be directly responsive to the concentration of an anion which either gives rise to a complex or a precipitate with the respective cations of the metal. Therefore, they are termed as **second-order electrodes** as they respond to an ion not directly involved in the electron transfer process. The silver-silver chloride electrode, as already described in Section 16.3.1.1.3, is a typical example of a second-order electrode. In this particular instance, the coated Ag wire when dipped in a solution, sufficient AgCl dissolves to saturate the layer of solution just in contact with the respective electrode surface. Thus, the Ag^+ ion concentration in the said layer of solution may be determined by the status of the solubility product (K_{sp}) equilibrium :

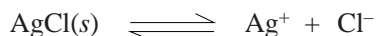

or
$$K_{sp} = [\text{Ag}^+] [\text{Cl}^-]$$

Disadvantages : The *four* serious disadvantages are, namely :

- (a) May be used effectively over a certain range of anion concentration only so that the solution must remain saturated with the substance coating the metal,
- (b) In the case of Ag-AgCl electrode, a very low Cl^- ion concentration would dissolve the AgCl-coating to a great extent,
- (c) Likewise, a very high concentration of Cl^- ion would result into the formation of soluble complex ions as shown below :

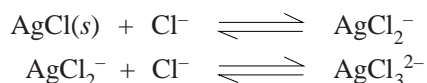

- (d) Ions like Br^- , I^- , SCN^- , CN^- and S^{2-} cause interference while using a Ag-AgCl electrode to estimate Cl^- ion concentrations because of the facts that these ions usually form salts with Ag^+ ion which are significantly less soluble than AgCl.

16.3.1.2.1.3. Inert electrodes

Inert electrodes comprise of chemically inert conductors, for instance : Au, Pt and C which do not necessarily take part either directly or indirectly in the various redox processes. However, the potential developed at an inert electrode solely depends upon both the nature as well as the prevailing concentration of the different redox-reagents present in the solution.

Example : A Pt-electrode placed in a solution consisting of both Fe^{3+} and Fe^{2+} ions develops a potential which is duly represented by the Nernst equation for ions as given below :

$$E = E^\circ_{\text{Fe}^{3+}/\text{Fe}^{2+}} - \frac{0.0592}{1} \log \frac{[\text{Fe}^{2+}]}{[\text{Fe}^{3+}]}$$

Advantages : The *two* main advantages of inert-electrodes are, namely :

- (a) Exhibit no chemical selectivity, and
- (b) Respond to any reversible redox-system.

16.3.1.2.2. Membrane Indicator Electrodes (or Ion-Selective Electrodes)

The underlying principle of this type of electrode is that the potential developed due to an unequal charge generated at the opposing surfaces of a 'special' membrane. The resulting charge at each surface of the membrane is exclusively controlled and monitored by the exact position of an equilibrium involving analyte ions, which in turn, solely depends upon the concentration of those ions present in the solution. Ion-selective electrodes occupy a very important place in the analytical chemistry by virtue of the fact that one may use the acquired skill, expertise and wisdom to design and commercially prepare membranes that are practically selective towards a specific ion besides producing potentials according to the Nernst-type equation. These are classified further into the following *four* kinds, namely :

- (i) Glass membrane electrodes,
- (ii) Polymer (liquid) membrane electrodes,
- (iii) Crystalline membrane electrodes, and
- (iv) Gas-sensing electrodes,

which will be described below briefly :

16.3.1.2.2.1. Glass Membrane Electrodes

The diagram of a typical glass-membrane electrode is depicted in Figure 16.6. The internal element essentially comprises of a Ag-AgCl electrode (B) dipped in a pH 7 buffer saturated with AgCl (A). The thin, ion-selective glass membrane (I) is carefully fused to the bottom of a high resistance non-responsive glass tube (H) so that the entire membrane may be immersed while taking measurements.

The half-cell of glass-membrane electrode may be expressed as :



According to the Nernst equation, the potential of the electrode is represented by :

$$E = E^\circ_{\text{AgCl}/\text{Ag}} - \frac{0.0592}{1} \log [\text{Cl}^-] + \frac{0.0592}{1} \log \frac{[\text{H}^+]_{\text{outside}}}{[\text{H}^+]_{\text{inside}}} \quad \dots(i)$$

Now, separating the ratio of H^+ ion concentrations into two log terms we may have :

$$E = E^\circ_{\text{AgCl}/\text{Ag}} - 0.0592 \log [\text{Cl}^-] + 0.0592 \log \frac{1}{[\text{H}^+]_{\text{inside}}} + 0.0592 \log [\text{H}^+]_{\text{outside}} \quad \dots(ii)$$

As the activities (*i.e.*, concentrations) of H^+ and Cl^- in the internal electrolyte solution are constant, the first three components on the right hand side of Eq. (ii) may be confined into a single constant, K, and the equation could be rewritten as :

$$E = K + 0.0592 \log [\text{H}^+]_{\text{outside}} \quad \dots(iii)$$

The various components of Figure 16.6 are as follows :

A = pH 7.0 buffer solution saturated with AgCl,

B = Ag-AgCl internal reference electrode,

C = Mercury connection,

D = Connecting wire,

E = Shield,

F = Cap,

G = Shielded and insulated connecting wire,

H = High resistance non-responsive glass, and

I = H⁺-selective glass membrane.

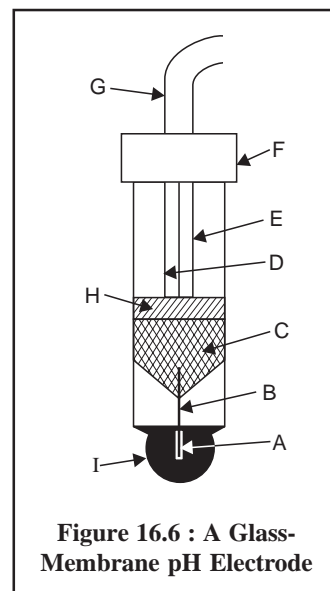
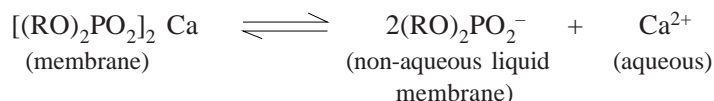

Figure 16.6 : A Glass-Membrane pH Electrode

16.3.1.2.2.2. Polymer (Liquid) Membrane Electrode

Figure 16.7. illustrates a calcium-ion polymer (liquid) membrane electrode. It has a close similarity to the glass pH electrode, and it essentially comprises of an internal Ag-AgCl electrode (B) and an internal reference solution having a fixed composition *e.g.*, aqueous CaCl₂ saturated with AgCl (C). The liquid calcium di (*n*-decyl) phosphate, [$\text{CH}_3(\text{CH}_2)_8\text{CH}_2\text{O}$]₂PO₂ Ca serves as the membrane, positioned at the lower end of the electrode, and strategically immobilized by a thin disk of PVC (polyvinyl chloride) (A) which is not penetrable with water.

Thus, the calcium di (*n*-decyl) phosphate forms an equilibrium with its ions at every membrane surface :



where, R = CH₃(CH₂)₈-CH₂- *i.e.*, *n*-decyl hydrocarbon chain.

Interestingly, the didecylphosphate anion represents a fixed component of the non-aqueous liquid membrane. As the concentration of Ca⁺ ions present in the solutions on either side of the membrane varies ; hence, the concentration of didecylphosphate anion at every membrane surface would also vary accordingly, thereby causing a potential that may be expressed by the following equation :

$$E = E^\circ_{\text{AgCl}/\text{Ag}^+} - \frac{0.0592}{1} \log [\text{Cl}^-] + \frac{0.0592}{2} \log \frac{[\text{Ca}^{2+}]_{\text{outside}}}{[\text{Ca}^{2+}]_{\text{inside}}} \quad \dots(i)$$

Again, separating the ratio of Ca²⁺ ion concentration into two log terms we have :

$$E = E^\circ_{\text{AgCl}/\text{Ag}^+} - \frac{0.0592}{1} \log [\text{Cl}^-] + \frac{0.0592}{2} \log \frac{1}{[\text{Ca}^{2+}]_{\text{inside}}} + \frac{0.0592}{2} \log [\text{Ca}^{2+}]_{\text{outside}} \quad \dots(ii)$$

Since the activities of Ca²⁺ and Cl⁻ in the internal electrolyte solution are more or less constant, the first three terms on the right hand side of Eq. (ii) may be combined to a single constant, K, and the same equation may be rewritten as follows :

$$E = K + \frac{0.0592}{2} \log [\text{Ca}^{2+}]_{\text{outside}} \quad \dots(iii)$$

The different essential components of Figure 16.7 are as stated below :

A = Calcium di (*n*-decyl)-phosphate immobilizes in PVC,

B = Silver-silver chloride electrode, and

C = Aqueous CaCl₂ saturated with AgCl.

16.3.1.2.2.3. Crystalline Membrane Electrodes

The crystalline membrane electrodes have a very close similarity to those of glass-membrane electrodes (see Section 16.3.1.2.2.1) except that glass has been replaced with crystalline membrane. In fact, these electrodes offer a means to devise responsive to anions by making use of a membrane containing specific anionic sites.

Example : Fluoride-ion Electrode : In this particular instance the membrane essentially comprises of a single crystal of lanthanum fluoride (LaF₃), usually doped with a slight trace of europium (II), Eu²⁺, so as to initiate the crystal defects required for establishing its electrical conductivity. Therefore, the potential developed at each surface of the membrane is finally determined by the exact status of the equilibrium :

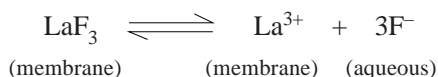

and is represented by the following equation :

$$E = K + \frac{0.0592}{1} \log [\text{F}^-]_{\text{outside}} = K - 0.0592 \log [\text{F}^-]_{\text{outside}}$$

Salient features of Fluoride-Ion Electrode are, namely :

- At low pH, F⁻ ion gets readily converted to the weak acid HF (pK_a = 3.17) thereby rendering the electrode insensitive,
- It is almost 10³ times more specific and selective for F⁻ ion as compared to other common anions, of course with the exception of OH⁻ ion, and
- This electrode can tolerate conveniently the maximum concentration of OH⁻ ion to the extent of $\frac{1}{10}$ th as compared to the F⁻ ion concentration.

Table 16.2 records the characteristics of certain selected crystalline-membrane electrodes.

Table 16.2 : Characteristics of Certain Selected Crystalline Membrane Electrodes

S.No.	Analyte Ion	Membrane Composition	Conc. Range (M)	Recommended pH Range	Selectivity Coefficients
1.	Br ⁻	AgBr/Ag ₂ S	10 ⁰ – 10 ⁻⁵	2 – 12	Cl ⁻ = 0.003 ; OH ⁻ = 3 × 10 ⁻⁵ ; I ⁻ = 5000 ; CN ⁻ >> 1
2.	CN ⁻	AgCN/Ag ₂ S	10 ⁰ – 10 ⁻⁶	11 – 13	Cl ⁻ = 1 × 10 ⁻⁶ ; Br = 2 × 10 ⁻⁴ ; I = 1.5
3.	Ag ⁺	Ag ₂ S	10 ⁰ – 10 ⁻⁷	2 – 9	Hg ²⁺ >> 1
4.	Pb ²⁺	PbS/Ag ₂ S	10 ⁻¹ – 10 ⁻⁶	3 – 7	Cd ²⁺ = 0.3 ; Zn ²⁺ = 2 × 10 ⁻⁴ ; Fe ²⁺ = 0.05

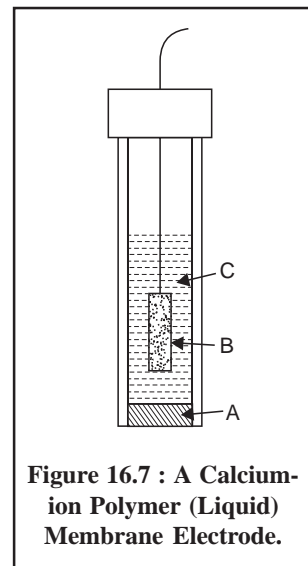

Figure 16.7 : A Calcium-ion Polymer (Liquid) Membrane Electrode.

16.3.1.2.2.4. Gas-Sensing Electrode

The schematic diagram of a gas-sensing electrode is illustrated in Figure 16.8, that comprises of essentially a reference electrode (E), a specific-ion electrode (B), and an internal electrolyte solution (F) contained in a cylindrical plastic tube (G). One end of the plastic tubing is provided with a thin, replaceable, gas-permeable membrane that separates the internal electrolyte solution from the external solution containing gaseous analyte. However, the exact composition and specifications of this gas-permeable membrane is usually described by its respective manufacturers. It is normally made up of a thin microporous film fabricated from a hydrophobic plastic material.

The various components of Figure 16.8 are as follows :

- A = Gas permeable membrane,
- B = Specific ion electrode (a glass electrode),
- C = 'O'-Ring to hold the membrane,
- D = External solution containing dissolved gaseous analyte,
- E = Reference electrode (a Ag/AgCl electrode),
- F = Internal electrolyte solution, and
- G = Plastic tube.

In general, it must fulfil the following requirements, namely :

- (a) It should act as a 100% barrier for both water and electrolytes *i.e.*, they must not pass through this membrane,
- (b) Pores of the film contain exclusively air or other gases to which it is exposed, and
- (c) A solution containing a particular gaseous-analyte, for instance CO₂, when comes in contact with the membrane the former migrates swiftly into the pores of the latter, as expressed by the following reaction :

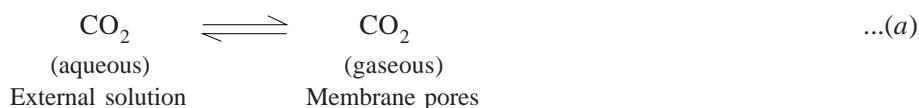

As the number of pores in the gas-permeable membrane are plenty, therefore, an equilibrium is established. Evidently, the carbon-dioxide present in the pores is in direct contact with the internal-electrolyte solution (F), thereby giving rise to a second equilibrium reaction that may be represented as follows :

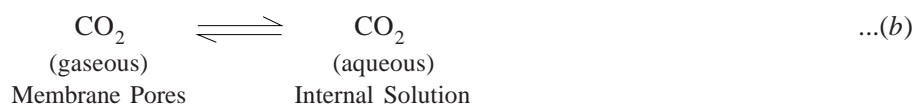

As a result of the above two reactions, Eq. (a) and Eq. (b), the external solution containing dissolved gaseous analyte (D) immediately attains an equilibrium with the film of internal electrolyte solution (F) present very close to the gas-permeable membrane (A). Thus, another equilibrium gets established that affords the pH of the internal-surface film to alter according to the following expression :

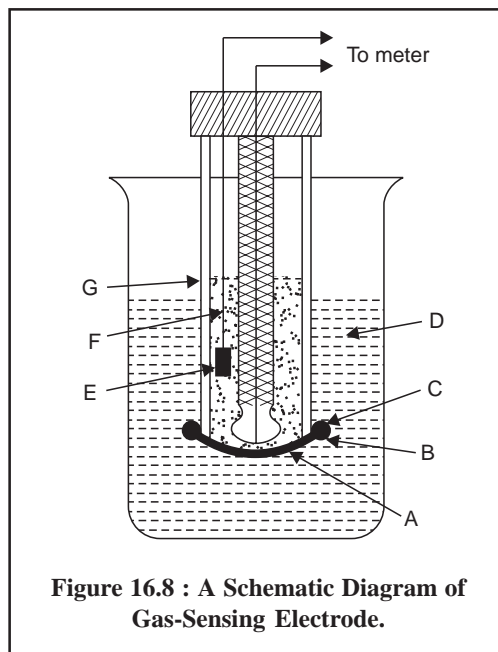
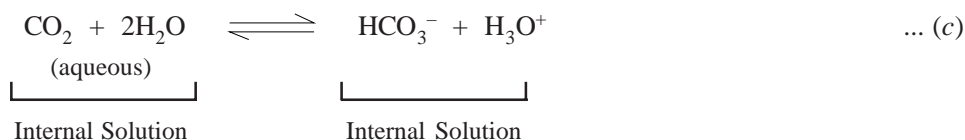
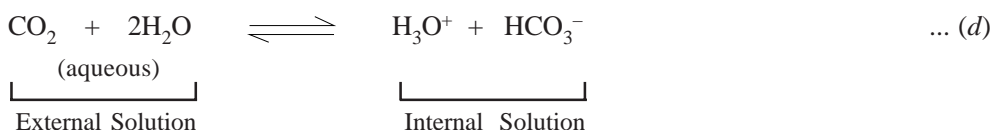

Figure 16.8 : A Schematic Diagram of Gas-Sensing Electrode.



The above change in pH is instantly detected by means of a Ag/AgCl reference electrode pair (E) dipped in the film of internal solution as shown in Figure 16.8.

Therefore, the net overall reaction caused by the entire aforesaid process may be achieved by simply summing up the *three* chemical reactions (a), (b), and (c) to give :



The equilibrium constant, K, for Eq. (d) may be represented by :

$$K = \frac{[\text{H}_3\text{O}^+][\text{HCO}_3^-]}{[\text{CO}_2 (\text{aqueous})]_{\text{external}}} \quad \dots (e)$$

Assuming that the concentration of HCO_3^- present in the internal-electrolyte solution (F) is made comparatively high such that its concentrations do not undergo any appreciable change due to the migrating CO_2 , we may have :

$$K_g = \frac{[\text{H}_3\text{O}^+][\text{HCO}_3^-]}{[\text{CO}_2 (\text{aqueous})]_{\text{external}}} = \frac{K}{[\text{HCO}_3^-]} \quad \dots (f)$$

Thus, Eq. (f) may be rewritten as follows :

$$a_1 = [\text{H}_3\text{O}^+] = K_g [\text{CO}_2 (\text{aqueous})]_{\text{external}} \quad \dots (g)$$

where, a_1 = Internal hydrogen ion activity

It is given that :

$$E_{\text{cell}} = L + 0.0592 \log a_1 \quad \dots (h)$$

Consequently, the potential of the electrode system present in the internal-electrolyte solution (F) is solely dependent on a_1 according to Eq. (h). Hence, substituting Eq. (g) into Eq. (h), we may have :

$$E_{\text{cell}} = L + 0.0592 \log K_g [\text{CO}_2 (\text{aqueous})]_{\text{external}}$$

or

$$E_{\text{cell}} = L' + 0.0592 \log [\text{CO}_2 (\text{aqueous})]_{\text{external}}$$

where, $L' = L + 0.0592 \log K_g$

In short, therefore, the potential of the cell comprising of the Ag/AgCl reference electrode (E) *i.e.*, the internal reference and the specific ion electrode (B) *i.e.*, the indicator electrode is normally determined by the CO_2 concentration of the external solution containing dissolved gaseous analyte.

Notes : (i) None of the electrodes (reference & indicator) ever gets in contact directly with the analyte solution, and

(ii) The only substances which may cause interference with the measurement of potential are dissolved gases which may have a free-access through the membrane, and in turn may affect the pH of the internal solution accordingly.

Selectivity of Gas-sensing Electrode : The selectivity of the gas-sensing electrode may be enhanced by making use of such an internal electrode which is particularly sensitive enough to certain species other than the H^+ ion.

Example : Nitrate-sensing electrode is employed to cater for a cell which will be sensitive exclusively to nitrogen dioxide (NO_2). The equilibrium of such a reaction may be represented as follows :

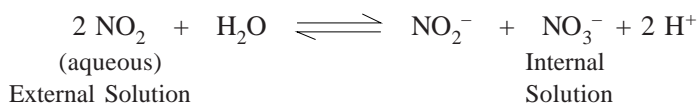

The nitrate-sensing electrode allows the determination of NO_2 in the presence of certain specific gases only, for instance, NH_3 , SO_2 and CO_2 , that will also affect the change in pH of the internal electrolyte solution significantly.

16.3.2. AUTOMATIC TITRATOR (PRESET END-POINT TITRATOR)

The schematic diagram of an automatic titrator* is shown in Figure 16.9.

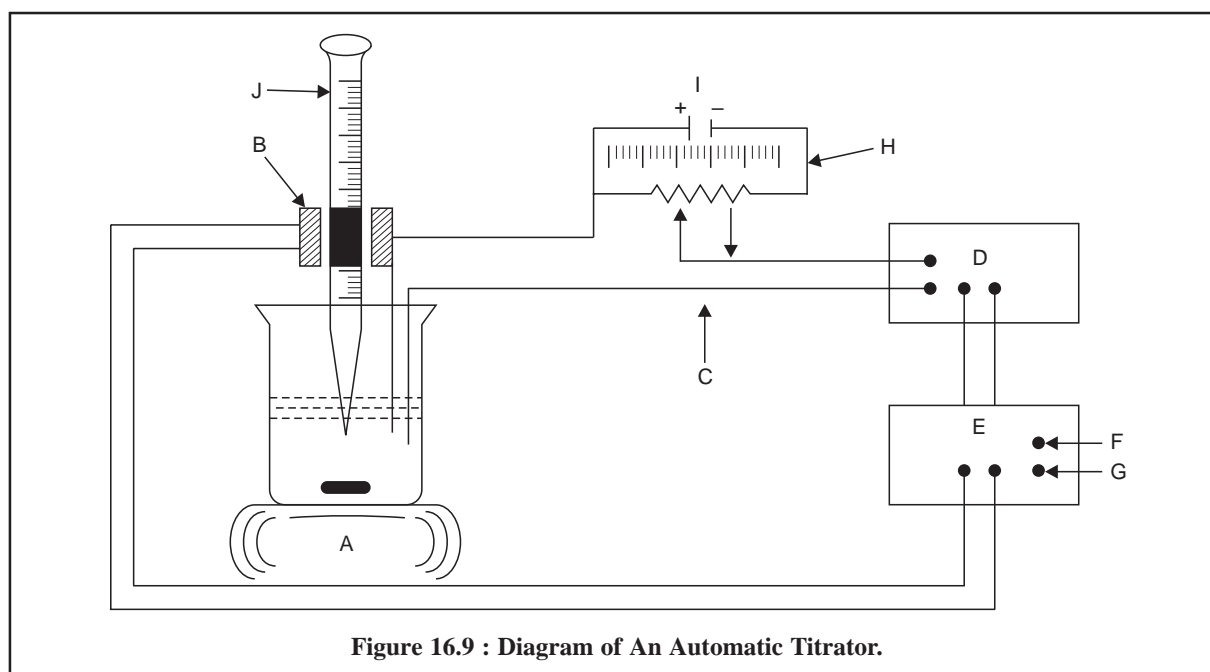

Figure 16.9 : Diagram of An Automatic Titrator.

The various components of Figure 16.9 are, namely :

- A = Magnetic stirrer with a Regulator,
- B = Solenoid valve, and
- C = Error Signal,
- D = Amplifier,
- E = Electronic Switch,
- F and G = AC-Source,
- H = End-point Potential,
- I = Calibrated Potentiometer, and
- J = Accurately calibrated Burette.

In this case a preset equivalence point potentiometer is applied at the two electrodes with the aid of a calibrated potentiometer (I). It will give rise to an “error” signal (C) provided a difference is caused between this potential and that of the electrodes. The feeble signal thus generated is duly amplified (D) and closes an electronic switch (E) which allows the electricity to flow through the solenoid operated valve (B) of the burette (J). As the titration proceeds, the error signal (C) starts approaching a zero value, subsequently the

*Svehla, G., *Potentiometric Titrations*, New York, Pergamon Press, 1978.

current to the solenoid valve (B) is instantly switched off, and finally the flow of titrant from the burette (J) comes to a halt. The solution of the sample is constantly and uniformly stirred with the help of a magnetic stirrer (A).

16.4. APPLICATIONS OF POTENTIOMETRIC TITRATIONS IN PHARMACEUTICAL ANALYSIS

Potentiometric titrations have been used extensively for assay of a number of official compounds. A few typical examples would be described here, namely : Nitrazepam ; Allopurinol ; and Chloridine hydrochloride.

A. Assay of Nitrazepam :

Materials Required : Nitrazepam : 0.25 g ; acetic anhydride : 25.0 ml ; perchloric acid (0.1 M) : 250 ml ; a Potentiometer ; a Magnetic Stirrer ; Burette (50 ml) ;

Theory : Nitrazepam is a weakly basic compound and hence, it may be titrated conveniently by means of a non-aqueous titration technique and determining the end-point potentiometrically.

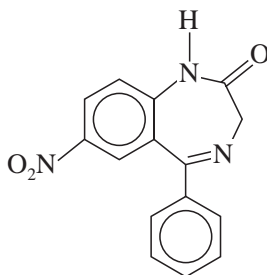

Nitrazepam

Procedure : Weigh accurately 0.25 g of nitrazepam and dissolve in 25.0 ml of acetic anhydride. Titrate with 0.1 M perchloric acid placed in a burette and adding it carefully into the beaker kept on a magnetic stirrer potentiometrically. Each ml of 0.1 M perchloric acid is equivalent to 28.13 mg of $C_{15}H_{11}N_3O_3$.

B. Assay of Allopurinol :

Materials Required : Allopurinol : 0.12 g ; dimethylformamide : 100.0 ml ; tetrabutylammonium hydroxide (0.1 M) : 1 L ;

Preparation of 0.1 M Tetrabutylammonium hydroxide (1 Litre) : Dissolve 40 g of tetrabutylammonium iodide in 90 ml of anhydrous methanol, add 20 g of finely powdered silver oxide and shake vigorously for 1 hour. Centrifuge a few ml of the mixture and test the supernatant liquid for iodides. If a positive reaction is obtained add a further 2 g of silver oxide and shake for 30 minutes. Repeat this procedure until the mixture is free from iodides, filter through a fine sintered-glass filter and wash the reaction vessel and filter with three 50-ml quantities of toluene. Add the washings to the filtrate and add sufficient toluene to produce 1000 ml. Pass dry carbon-dioxide free N_2 through the solution for 5 minutes.

Standardization of 0.1 M Tetrabutylammonium Hydroxide : To 10 ml of dimethylformamide add 0.05 ml of a 0.3 % w/v solution of thymol blue in methanol and titrate with the tetrabutylammonium hydroxide solution until a pure blue colour is produced. Immediately add 0.2 g of benzoic acid, stir to effect solution and titrate with the tetrabutylammonium hydroxide solution until the pure blue colour is restored. Protect the solution from atmospheric CO_2 throughout the titration. The volume of titrant used in the second titration represents the amount of tetrabutylammonium hydroxide required. Each ml of 0.1 M tetrabutylammonium hydroxide Vs is equivalent to 12.21 mg of $C_7H_6O_2$.

Procedure : Dissolve 0.12 g of accurately weighed allopurinol in 50 ml of dimethylformamide, with gentle heating, if necessary. Titrate to the colour change of the indicator that corresponds to the maximum absolute value of dE/dV in a potentiometric titration (where E is the electromotive force and V is the

volume of the titrant). Each ml of 0.1 M tetrabutylammonium hydroxide Vs is equivalent to 13.61 mg of $C_5H_4N_4O$.

C. Clonidine Hydrochloride :

Materials Required : Clonidine hydrochloride : 0.2 g ; ethanol (96%) : 100 ml ; 0.1 M ethanolic sodium hydroxide Vs : 1 L (Add 3.3 g of 10 M sodium hydroxide solution to 250 ml of absolute ethanol).

Standardization of 0.1 M Ethanolic Sodium Hydroxide Solution Vs : Dissolve 0.2 g of benzoic acid in a mixture of 10 ml of ethanol (96%) and 2 ml of water and titrate with the ethanolic sodium hydroxide solution using 0.2 ml of thymolphthalein solution (a 0.1 % w/v solution of thymolphthalein in ethanol (96%)) as indicator. Each ml of 0.1 M ethanolic sodium hydroxide Vs is equivalent to 12.21 mg of $C_7H_6O_2$.

Procedure : Dissolve 0.2 g of clonidine hydrochloride in 70 ml of ethanol (96%) and titrate with 0.1M ethanolic sodium hydroxide Vs determining the end-point potentiometrically. Each ml of 0.1 M ethanolic sodium hydroxide Vs is equivalent to 26.66 mg of $C_9H_9Cl_2N_3$, HCl.

16.4.1. COGNATE ASSAYS

A plethora of official drugs are assayed by the potentiometric method in various *official compendia*, and a few selected examples are given in Table 16.3, which may be assayed potentiometrically :

Table 16.3 : Cognate Assays of Official Compounds

S.No.	Name of Substance	Qty. Prescribed	Titrant/ Indicator	Calculations
1.	Apomorphine Hydrochloride	0.25 g	Perchloric Acid (0.1M)	Each ml of 0.1 M $HClO_4 \equiv 30.38$ mg of $C_{17}H_{17}NO_2 \cdot HCl$
2.	Azathioprine	0.25 g	Tetrabutylammonium hydroxide (0.1 M)	Each ml of 0.1 M Tetrabutylammonium hydroxide $\equiv 27.73$ mg of $C_9H_7N_7O_2S$
3.	Bendrofluazide	0.2 g	-do-	Each ml of 0.1 M Tetrabutylammonium hydroxide = 21.07 mg of $C_{15}H_{14}F_3N_3O_4S_2$
4.	Bisacodyl	0.3 g	Perchloric Acid (0.1 M)	Each ml of 0.1 M $HClO_4 \equiv 36.14$ mg of $C_{22}H_{19}NO_4$
5.	Carbidopa	0.15 g	-do-	Each ml of 0.1 M $HClO_4 \equiv 22.62$ mg of $C_{10}H_{14}N_2O_4$
6.	Cimetidine	0.2 g	-do-	Each ml of 0.1 M $HClO_4 \equiv 25.23$ mg of $C_{10}H_{16}N_6S$
7.	Disulfiram	0.45 g	Silver Nitrate (0.1 M)	Each ml of 0.1 M $AgNO_3 \equiv 59.30$ mg of $C_{10}H_{20}N_2S_4O$
8.	Ethinylestradiol	0.2 g	Sodium Hydroxide (0.1 M)	Each ml of 0.1 M $NaOH \equiv 29.64$ mg of $C_{20}H_{24}O_2$
9.	Etofylline	0.2 g	Perchloric Acid (0.1 M)	Each ml of 0.1 M $HClO_4 \equiv 22.42$ mg of $C_9H_{12}N_4O_3$
10.	Flunitrazepam	0.25 g	-do-	Each ml of 0.1 M $HClO_4 \equiv 31.33$ mg of $C_{16}H_{12}FN_3O_3$
11.	Glutethimide	0.15 g	Ethanolic NaOH (0.1M)	Each ml of 0.1 M $NaOH \equiv 21.73$ mg of $C_{13}H_{15}NO_2$
12.	Lomustine	0.2 g	Silver Nitrate (0.05 M)	Each ml of 0.05 M $AgNO_3 \equiv 11.68$ mg of $C_9H_{16}ClN_3O_2$

THEORETICAL AND PRACTICAL EXERCISES

1. 'The actual strength of a broad spectrum of **'solutes'** can be determined quantitatively by forming an appropriate electrochemical cell' Justify the above statement with the help of Nernst Equation.
2. (a) What are the two major disadvantages of **'Direct Potentiometry'** ? Explain.
(b) How can one implement **'remedial measures'** to make potentiometric titrations into an efficacious method of quantitative analytical technique ? Explain.
3. Discuss in an elaborated manner the various means of **'potentiometric titrations'** in the following reaction variants :

(a) Neutralization reactions,	(b) Redox reactions,
(c) Precipitation reactions,	(d) Complexation reactions, and
(e) Potentiometric titrations in non-aqueous solvents.	
4. Potentiometric titration curves between 25 ml of 0.01 M NaF and 0.01 M La (NO₃)₃ may be obtained as the following **three** predominant variants, namely :

(a) Sigmoid (Regular) Curve,	(b) First Derivative Curve, and
(c) Second Derivative Curve.	

With the help of a diagrammatic neat-sketch of each curve explain and affirm which one gives the most reliable **'equivalence point'** and why.
5. Describe a potentiometric titration assembly with a well-labelled diagram. Briefly enumerate its working systematically.
6. What are the tow major types of 'Electrodes' one may come across in potentiometric method of analysis ? Discuss the working of at least one electrode from each category along with its diagrammatic description, working and advantages.
7. Do you think an **'Automatic Titrator'** (Preset End-Point Titrator) is a technological advancement in potentiometric titration ?
Expatiate its efficacy and advantages in a busy **'quality assurance laboratory'** with a neat-labelled diagram and its *modus operandi*.
8. How would you carry out the assay of the following **'drugs'** ?

(i) Nitrazepam,	(ii) Allopurinol,
(iii) Bendrofluzide,	(iv) Cimetidine,
(v) Lomustine, and	(vi) Ethinyloestradiol.

RECOMMENDED READINGS

1. Eisenman, G., **Glass Electrodes for Hydrogens and Other Cations**, New York, Marcel Dekker, 1967.
2. Weissberger, A. and B.W. Rossiter, Eds, **Physical Methods of Chemistry**, Part II A, Vol. I, New York, Wiley-Interscience, 1971.
3. Nurnberg, H.W., Ed, **Electroanalytical Chemistry**, New York, John Wiley & Sons, 1974.
4. Foreman, J.K. and P.B. Stockwell, **Automatic Chemical Analysis**, New York, Wiley, 1975.
5. Freiser, H., Ed., **Ion Selective Electrodes in Analytical Chemistry**, New York, Plenum Press, 1978.
6. Veseley, J., D. Weiss and K. Stulik, **Analysis with Ion Selective Electrodes**, New York, Wiley, 1979.
7. Koryta, J. and K. Stulike, **Ion-Selective Electrodes**, 2nd. ed., Cambridge, Cambridge University Press, 1983.
8. Vassos, B.H. and G.W. Ewing, **Electroanalytical Chemistry**, New York, John Wiley and Sons, 1983.
9. Serjeant, E.P., **Potentiometry and Potentiometric Titrations**, New York, John Wiley & Sons, Inc., 1984.
10. Bard, A.J., R. Parsons, and J. Jordan, **Standard Potentials in Aqueous Solution**, New York, Marcel Deller Inc., 1985.
11. Reiger, P.H., **Electrochemistry**, Englewood Cliffs, N.J., Prentice Hall, 1987.
12. Jeffery, G.H., J. Bassett., J. Mendham and R.C. Denney, **Vogel's Textbook of Quantitative Chemical Analysis**, 5th ed., New York, Longman Scientific & Technical, 1989.

17

AMPEROMETRIC METHODS

CONTAINS :

- 17.1 Introduction
- 17.2 Theory
 - 17.2.1 Titration curves
 - 17.2.2 Corrections for the volume change
 - 17.2.3 Advantages of amperometric titrations
- 17.3 Instrumentation
 - 17.3.1 Amperometric titrations with the dropping mercury electrode
 - 17.3.2 Amperometric titrations with a rotating platinum electrode
 - 17.2.3 Amperometric titrations with twin-polarized microelectrodes (biamperometric titrations or dead-stop-end-point method)
- 17.4 Applications of amperometric titrations in pharmaceutical substances
 - 17.4.1 Procainamide hydrochloride
 - 17.4.2 Cognate assay
 - 17.4.3 Assay of nickel with dimethylglyoxime
 - 17.4.4 Assay of lead with potassium dichromate solution

17.1. INTRODUCTION

An **amperometric method** or **amperometry** is concerned with the measurement of current under a constant applied voltage ; and under such experimental parameters the concentration of the '**analyte**' exclusively determines the quantum and magnitude of the current. Hence, these measurements may be employed effectively to record the alteration in concentration of an ion in question in the course of a titration, and ultimately the end-point is established. This specific process is commonly referred to as *amperometric method* or *amperometry*.

In this particular case, the total current flowing shall remain almost equal to the current carried by the ions that undergoes equal electrolytic migration together with the current caused on account of the diffusion of the ions. Thus, we have :

$$I = I_d + I_m$$

where I = Total current,

I_d = Diffusion current, and

I_m = Migration current.

An awkward situation arises when dealing with a dilute solution where it has been observed that the depletion of the electrode layer ultimately leads to an enhancement of the resistance of the solution and thereby affecting subsequently an alteration in the Ohm's Law potential drop ($I \times R$) in the cell. This ultimately gives rise to a doubtful observed potential operative at the electrode. In order to overcome this serious anomaly, it is a normal practice to add an excess of an indifferent electrolyte to the system, such as : 0.1 M KCl, which renders the solution to remain stable at a low and constant resistance, whereas the migration current (I_m) of the species under examination almost vanishes *i.e.*, $I = I_d$.

The ion under investigation, whose rate of diffusion at the electrode surface is governed by **Fick's Law** represented as under :

$$\frac{\partial c}{\partial t} = \frac{D\partial^2 c}{\partial x^2}$$

where, D = Diffusion coefficient,

C = Concentration,

t = Time, and

x = Distance from the electrode surface.

Thus, the potential of the electrode is controlled and monitored by the **Nernst Equation** as shown below :

$$E = E^\circ + \frac{RT}{nF} \ln \frac{a_{\text{ox}}}{a_{\text{red}}}$$

Salient Features of Amperometric Methods : The various salient features of amperometric titrations are enumerated below :

- (a) It is less dependent upon the characteristics of the electrode,
- (b) It is quite independent of the nature and type of the supporting electrolyte,
- (c) It does not require a constant temperature in the course of a titration but it should not necessarily be fixed accurately,
- (d) The substance under investigation may not essentially be reactive at the electrode ; whereas either a reactive reagent or a product is just sufficient for a successful amperometric titration, and
- (e) The amperometric method is inherently more accurate and precise, and therefore, has an edge as compared to the polarographic method.

17.2. THEORY

Assuming that the migration current (I_m) is virtually eliminated by the addition of a reasonably enough supporting electrolyte then the only cardinal factor which would affect the limiting current would be the rate of diffusion of the electro-active substance from the main body of the solution to the surface of the electrode.

Thus, we may have :

$$\text{Diffusion current} = \text{Limiting current} - \text{Residual current}$$

It follows from above that the diffusion current is directly proportional to the concentration of the electro-active substance present in the solution. Now, if a situation is created whereby a portion of the electro-active substance is eliminated by interaction with a specific reagent, the diffusion current shall decrease significantly. It represents the fundamental underlying principle of amperometric method or amperometry. Hence, at an appropriate applied voltage the apparent diffusion current is measured as a function of the volume of the titrating solution added. Now, if a graph is plotted between the 'current' against the 'volume of reagent added', the end-point will be represented by the point of intersection of two lines indicating the change of current both before and after the equivalence is achieved.

17.2.1 TITRATION CURVES

The most commonly obtained various kinds of curves encountered in amperometric methods are illustrated in Fig. 17.1 (a) through (d) ; and each of them shall be discussed briefly as follows :

Fig. 17.1 (a) : It represents a titration wherein the analyte reacts at the electrode whereas the reagent does not. In other words, only the substance under titration gives rise to a diffusion current ; whereby the electro-active substance is removed from the solution by means of precipitation with an inactive substance.

Example : The titration of Pb^{2+} with SO_4^{2-} or $\text{C}_2\text{O}_4^{2-}$ ions. An appreciably high potential is usually applied to yield a diffusion current for lead. From Fig. : 1(A), one may evidently observe a linear decrease in current because Pb^{2+} ions are removed from the solution by precipitation. The small curvature just prior to the end-point (or equivalence point) shows the incompleteness of the analytical reaction in this particular region. However, the end-point may be achieved by extrapolation of the linear portions, as shown in the said figure.

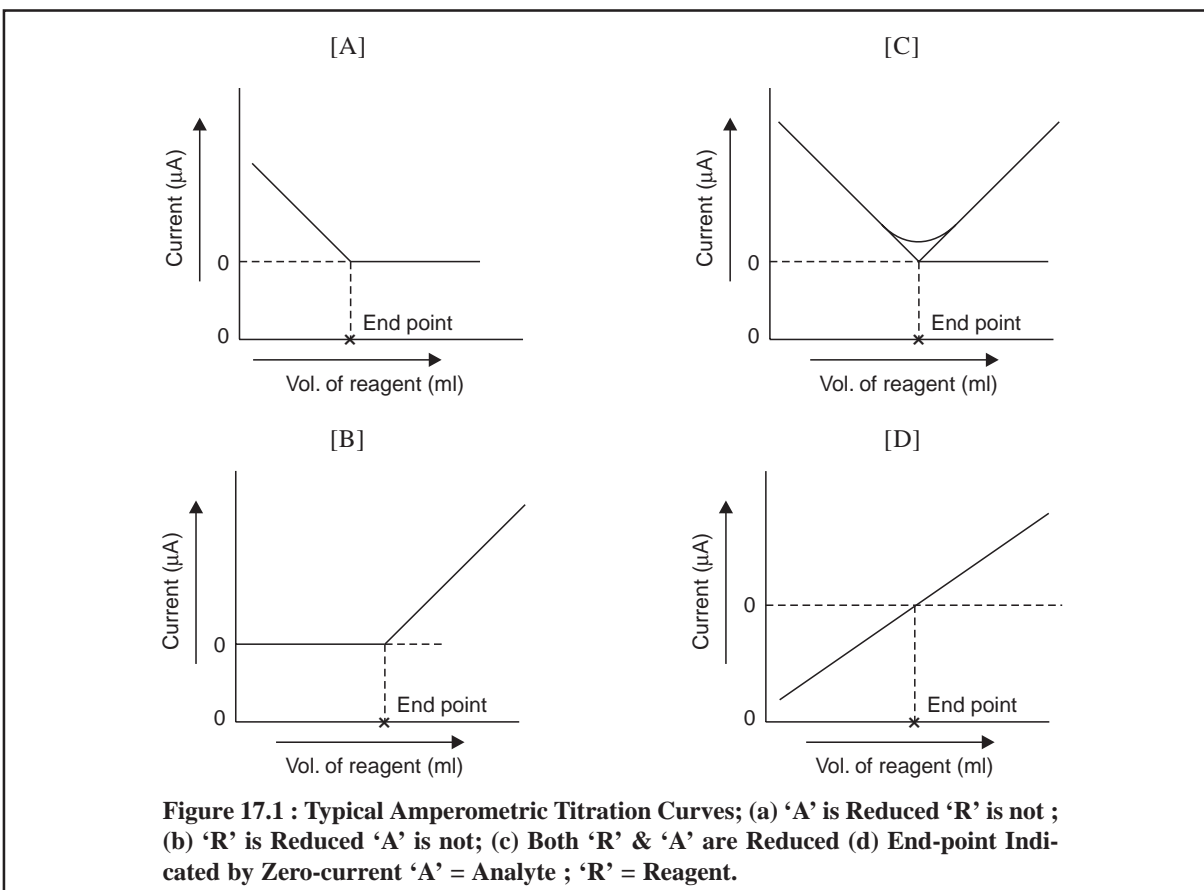

Figure 17.1 (b) : It designates typical of an amperometric titration curve wherein the reagent exclusively reacts at the microelectrode surface and the analyte does not. In other words, the reagent gives rise to a diffusion current, whereas the solute does not ; it means an electro-active precipitating reagent is being added to an inactive substance.

Examples : (a) Titration of Mg^{2+} with 8-hydroxyquinoline. In this particular instance, a diffusion current for 8-hydroxyquinoline is normally achieved at -1.6 V Vs Standard Calomel Electrode (SCE), whereas Mg^{2+} ion is more or less inert at this potential.

(b) Titration of Ba^{2+} or Pb^{2+} ions with SO_4^{2-} ions.

Figure 17.1 (c) : It represents an amperometric method wherein the solute as well as the titrating reagent afford diffusion currents ; and give rise to a sharp V-shaped curve. The end-point may be obtained by extrapolation of the lower-end of the V-shaped portion of the curve as depicted in the above Figure.

Examples : (a) Titration of Pb^{2+} ion with $\text{Cr}_2\text{O}_7^{2-}$ ion. The Figure : 17.1 (c) corresponds to the amperometric titrations of Pb^{2+} and $\text{Cr}_2\text{O}_7^{2-}$ ion at an applied potential more than -1.0 V ; when both these ions afford diffusion currents at this very potential and the end-point is duly signalled corresponding to a minimum in the curve.

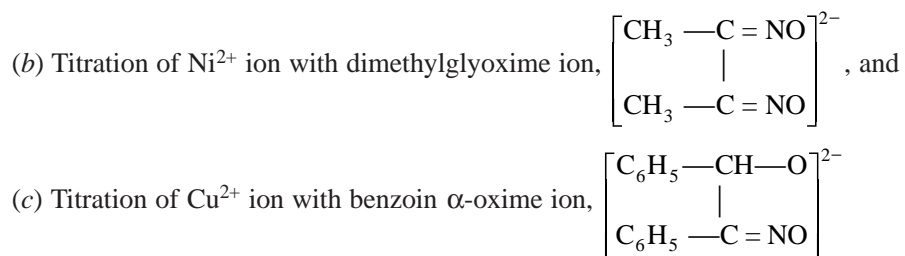

Figure 17.1 (d) : In this particular instance the current undergoes a change from cathodic to anodic or *vice-versa*. Thus, the final end-point of the potentiometric titration is indicated by a zero-current as depicted in Figure 17.1 (d). Since the resulting diffusion coefficient of the reagent is found to be slightly different from the corresponding substance under titration, therefore, the slope of the line just before the end-point actually differs very slightly from that after the end-point. However, in actual practice it is rather convenient to add the reagent unless and until the current attains a zero value.

Examples: (a) Titration of I^- ion with Hg^{2+} ion (as nitrate),

(b) Titration of Ti^{3+} ion in an acidified tartaric acid,

$[\text{CH}(\text{OH})\text{COOH}]_2$, medium with Fe^{3+} ion.

In addition to the above *four* types of amperometric methods cited, there also exist a plethora of titrations involving neutralization and complex ion formation that have been accomplished successfully, for instance :

- (i) Amperometric method for the study of precipitation reactions, *e.g.*, salicylaldehyde oxime, dimethylglyoxime, have been used for such type of studies.
- (ii) Halides, such as : I^- , Br^- and Cl^- have been titrated at a less negative potential by virtue of the fact that in these titrations the main indicator reaction is the deposition of silver from aquo-silver ions.
- (iii) Micromolecular solutions of Cd^{2+} ions against ethylene diaminetetra-acetic acid (EDTA) have been carried out amperometrically.

17.2.2. CORRECTIONS FOR THE VOLUME CHANGE

The corrections for the volume change may be affected by adopting either of the *two* methods described below namely :

Method I : In order to obtain plots between current (μA) and volume of reagent (ml) specifically with linear regions both before and after the end-point (or equivalence point), it is absolutely necessary to apply the corrections for the volume change which results from the added titrant. This correction is applied by multiplying the measured corresponding diffusion current (I_d) by the following factor :

$$\frac{V + v}{V}$$

where, V = Initial volume of the solution, and

v = Volume of the titrating reagent added.

Method II : The above correction caused due to the volume change may be eliminated to a great extent by making use of the reagent at a concentration of 10 to 20 times higher than that of the corresponding solute, and subsequently adding the same from a semimicro-burette very carefully. The use of concentrated reagents have the following advantages, namely :

- (a) Relatively very small amount of dissolved O_2 is incorporated into the system, which eliminates completely the prolonged bubbling of inert gas (*e.g.*, N_2) through the medium after each addition of the reagent, and
- (b) Elimination of '*migration current*' by simple addition of enough supporting electrolyte. If need be, an appropriate maximum suppressor can also be incorporated judiciously.

17.2.3. ADVANTAGES OF AMPEROMETRIC TITRATIONS

A few cardinal advantages of amperometric titrations are described below, namely :

1. The amperometric titration may normally be performed very quickly, because the equivalence point (or end-point) is determined graphically. A series of measurements at constant applied voltage just prior and latter to the end-point are more than enough.
2. The titrations can be carried out both satisfactorily and effectively in such situations where the solubility relations offer erroneous and unsatisfactory results given by visual indicator and potentiometric methods. For instance :
 - (a) A reaction product which is hydrolysed significantly *e.g.*, acid base titrations, and
 - (b) A reaction product that is appreciably insoluble *e.g.*, precipitation reaction.

It is quite evident that the readings in the vicinity of end-point offer practically no specific value and importance in amperometric titrations. Because the readings are mostly taken in particular zones where there exists either an excess of reagent or of titrant, and which specific points the hydrolysis or solubility is entirely suppressed by the effect of Mass Action. The point of intersection of these lines ultimately gives rise to the desired end-point.

3. A good number of amperometric titrations may be performed on considerably dilute solutions (say, 10^{-4} M) at which neither potentiometric nor visual indicator methods ever can give precise and accurate results, and
4. In order to eliminate the migration current (I_m) completely either the '*foreign salts*' already present cause little interference or invariably added so as to serve as the '*supporting electrolyte*'.

17.3. INSTRUMENTATION

The amperometric titrations can be accomplished by any one of the *three* methods, namely :

- (i) Amperometric titrations with the dropping mercury electrode,
- (ii) Amperometric titrations with a rotating platinum microelectrode, and
- (iii) Amperometric titrations with twin-polarized microelectrodes (or **Biamperometric Titrations** or **Dead-stop-end-point method**).

These *three* techniques will be discussed in the sections that follow.

17.3.1. AMPEROMETRIC TITRATIONS WITH THE DROPPING MERCURY ELECTRODE

Figure 17.2 (a) and (b) illustrates the schematic diagram of amperometric titrations with the dropping mercury electrode having a titration-cell and an electric circuit respectively.

The titration-cell Figure 17.2 (a) essentially comprises of a pyrex 100-ml, four-necked, flat-bottomed flask. A semimicro burette (B) (graduated in 0.01 ml), a 2-way gas-inlet tube (A) to enable N_2 to pass either through the solution or simply over its surface, a dropping mercury electrode (C) and an agar-potassium salt-bridge* are duly fitted into the four necks with the help of air-tight rubber stoppers.

The electrical circuit, Figure 17.2 (b), consists of two 1.5 V dry cells that provides a voltage applied to the above titration cell. It is duly controlled and monitored by the potential divider (R) and is conveniently measured with the help of a digital voltmeter (V). Finally, the current flowing through the circuit may be read out on the micro-ammeter (M) installed.

*The agar-salt bridge is usually made from a gel which is 3% agar and contains enough KCl to saturate the solution at room temperature. An agar- KNO_3 bridge is used when Cl^- ion interferes.

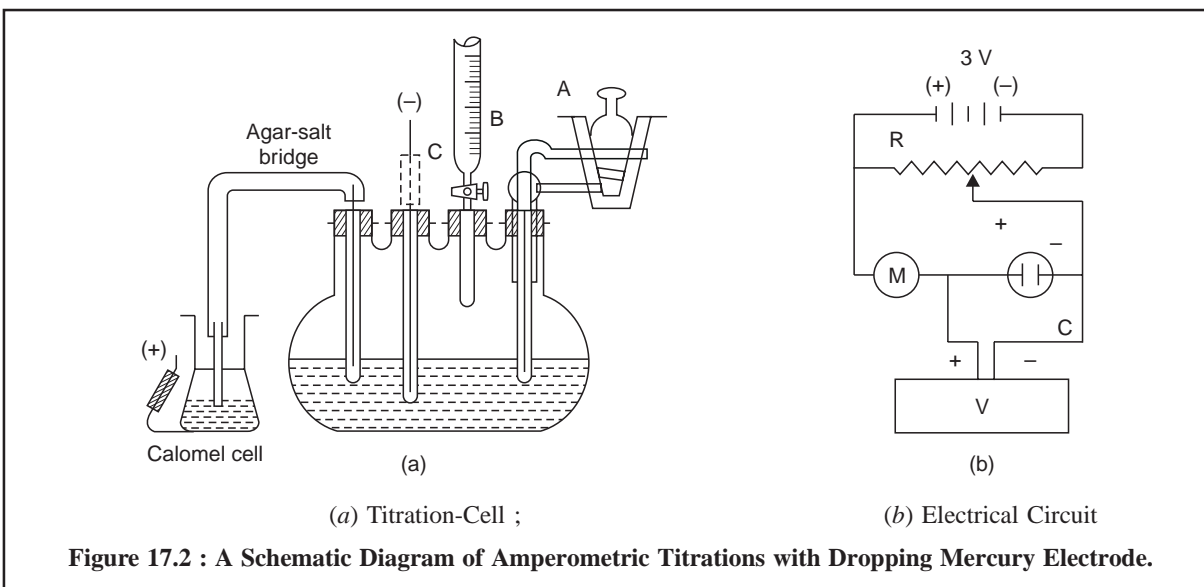

For Figure : 17.2 [a]

A = 2-Way gas-inlet tube,

B = Semimicro burette (graduated in 0.01 ml), and

C = Dropping mercury electrode.

The following steps may be carried out in a sequential manner for an amperometric titration, namely :

1. A known volume of the solution under investigation is introduced in the titration cell,
2. The apparatus is assembled and electrical connections are duly completed with dropping mercury electrode (C) as cathode and saturated calomel half-cell as anode,
3. A slow stream of pure analytical grade N_2 – gas is bubbled through the solution for 15 minutes to get rid of dissolved O_2 completely,
4. Applied voltage is adjusted to the desired value, and the initial diffusion current (I_d) is noted carefully,
5. A known volume of the reagent is introduced from the semimicro burette (B), while N_2 is again bubbled through the solution for about 2 minutes to ensure thorough mixing as well as complete elimination of traces of O_2 from the added liquid,
6. The flow of N_2 gas through the solution is stopped, but is continued to be passed over the surface of the solution gently so as to maintain an O_2 free inert atmosphere in the reaction vessel,
7. The current (μA) and microburette readings are recorded simultaneously, and
8. Finally, the said procedure is repeated until sufficient readings have been obtained to allow the equivalence point to be determined as the intersection of the two linear portions of the graph thus achieved.

For Figure : 17.2 [b]

R = Potential divider (a 50 – 100 Ω variable resistance),

C = Cell,

M = Micro-ammeter (μA), and

V = Digital voltmeter.

17.3.2. AMPEROMETRIC TITRATIONS WITH A ROTATING PLATINUM MICROELECTRODE

The rotating platinum microelectrode was first introduced by Laitinen and Kolthoff in 1941. Figure 17.3 (a) depicts a simple rotating platinum microelectrode which is made out from an usual standard ‘mercury seal’. A platinum wire (length : 5.0 mm ; diameter : 0.5 mm) protrudes from the lower end wall of a 21

cm long 6 mm glass tubing, which is bent at an angle of 90°. There are holes (H) in the stem of the mercury reservoir for making electrical contact with it. The mercury reservoir is provided with a flange fitted inward to prevent Hg from being thrown out.

Figure 17.3 (b) illustrates the electric circuit. The electrical connection is duly done to the electrode by means of a strong amalgamated Cu-wire passing through the glass tubing to the lower end of the Hg covering the sealed-in platinum wire ; the upper end of which passes through a small hole made in the stem of the stirrer and dips well into the Hg present in the Hg seal. Subsequently, a wire from the Hg seal is connected to the source of applied voltage. The glass tubing serves as the stem of the electrode that is rotated at a constant speed of 600 rpm.

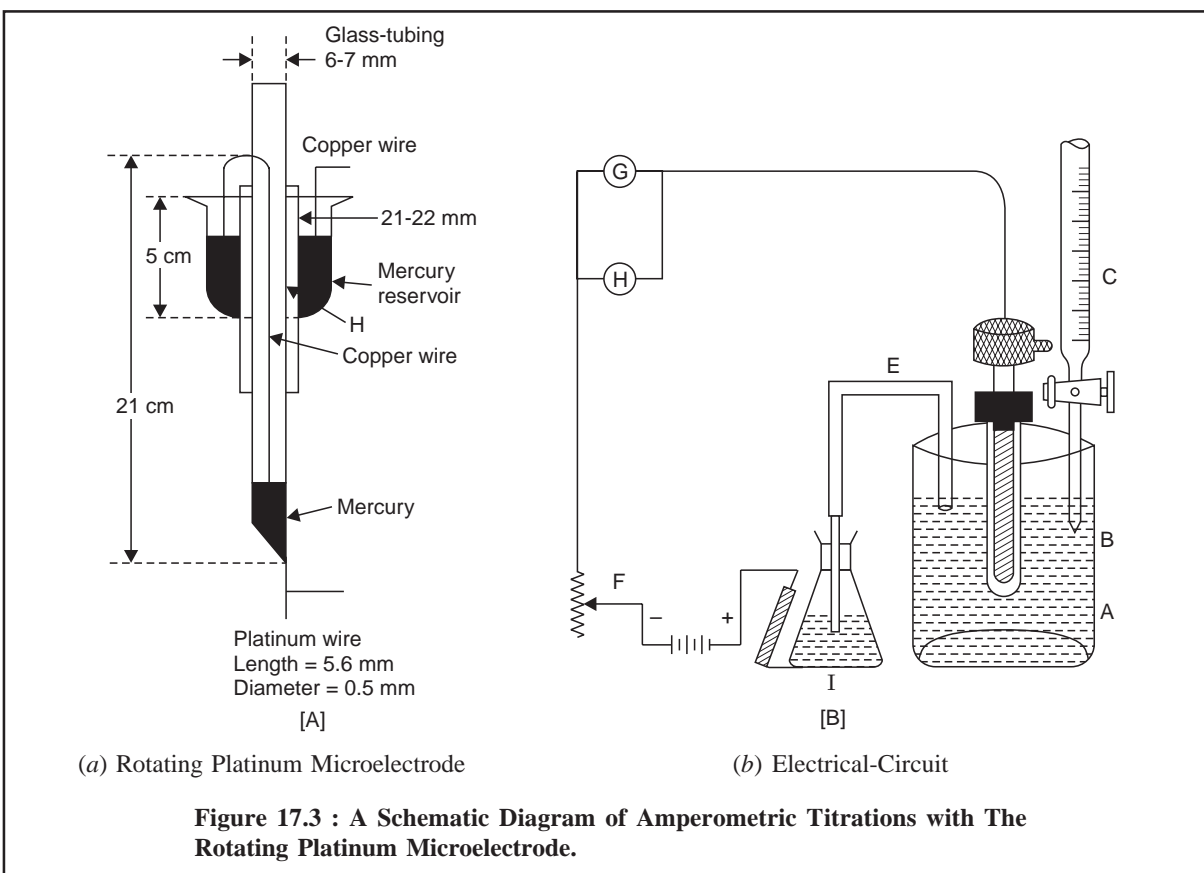

For Figure 17.3 (a)

- H = Hole in the stem of glass-tubing for making electrical contact with the Mercury Reservoir ;
- F = Flange fitted inward of the Hg-Reservoir to prevent Hg from being thrown out.

For Figure 17.3 (b)

- A = Platinum wire,
- B = Hg filled glass tubing,
- C = Semimicro burette (graduated in 0.01 ml),
- D = Rotating platinum microelectrode,
- E = Salt bridge,
- F = Potential divider,
- G = Galvanometer,
- H = Sensitivity shunt, and
- I = Calomel cell.

17.3.3. AMPEROMETRIC TITRATIONS WITH TWIN-POLARIZED MICROELECTRODES (BIAMPEROMETRIC TITRATIONS OR DEAD-STOP-END-POINT METHOD)

Dead-stop-end-point method was first introduced by Foulk and Bawden* in 1926. Evidently, this particular technique is a modification of the classical amperometric titration. This technique is specifically applicable to only such systems where the phenomenon of oxidation-reduction exists both before as well as after the equivalence point has been duly accomplished.

It essentially makes use of two identical, stationary microelectrodes immersed in a well stirred solution of the sample. A small potential ranging between these electrodes ; and the resulting current is measured subsequently as a function of the volume of reagent added. The end-point is distinctly characterized by a sudden current rise from zero or a decrease in the current to zero or a minimum at zero in a V-shaped curve.

Though this technique was first used in 1926, but it received its due recognition only around 1950**.

Figure 17.4 represents a simple diagram of an amperometric titration assembly with twin-polarized microelectrodes.

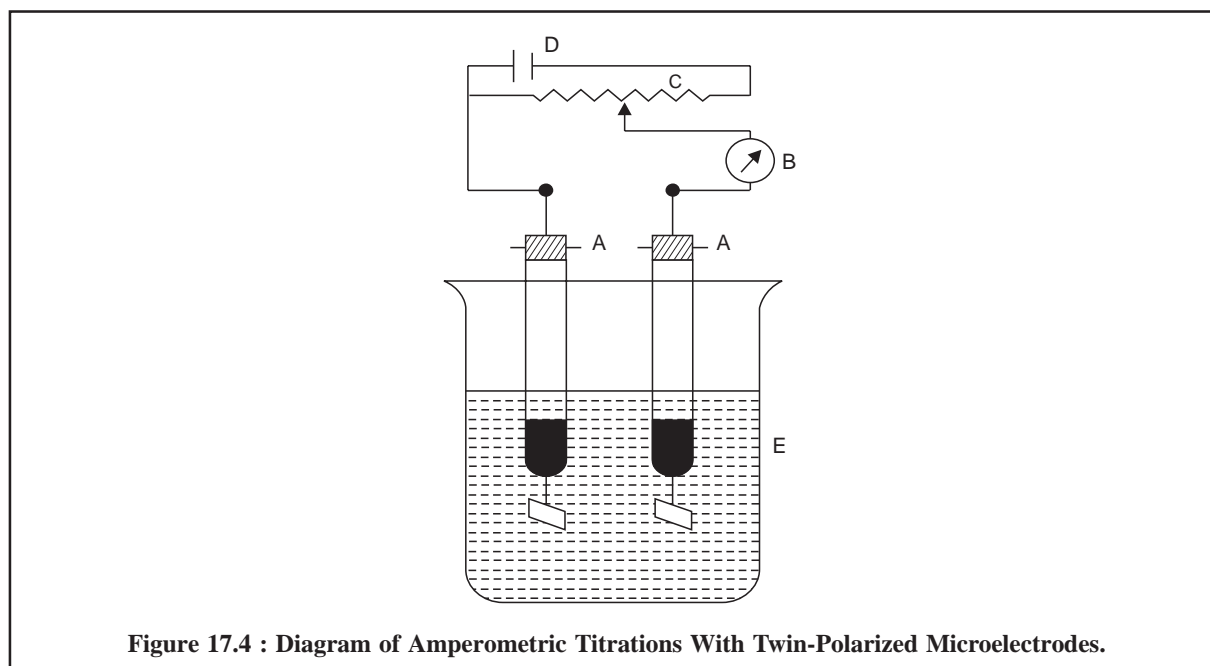

Figure 17.4 : Diagram of Amperometric Titrations With Twin-Polarized Microelectrodes.

The various components are as follows :

A, A = Twin-polarized Platinum microelectrodes,

B = Micro-ammeter (μA),

C = 500Ω , 0.5 watt potentiometer,

D = 3-Volt dry torch cell or a 2-volt accumulator

E = Reaction vessel.

The potentiometer is adjusted in such a fashion that there is a distinct potential drop of about 80 to 100 millivolts between the two platinum electrodes.

* Foulk, C.W., and A.T. Bawden, *J. Amer. Chem. Soc.*, **48**, 2025, 1926

** Lingane, J.J. *Electroanalytical Chemistry*, 2nd. ed., New York, Interscience, 1958.

17.4. APPLICATIONS OF AMPEROMETRIC TITRATIONS IN PHARMACEUTICAL SUBSTANCES

Some pharmaceutical substances are assayed by amperometric titrations, namely : procainamide hydrochloride ;

17.4.1. PROCAINAMIDE HYDROCHLORIDE

Materials Required : Procainamide hydrochloride : 0.25 g ; 2M hydrochloric acid : 100 ml ; potassium bromide : 3 g ; 0.1 M sodium nitrite Vs (dissolve sodium nitrite in sufficient water to produce 1000 ml) ; Standardization of 0.1 M Sodium Nitrite Vs : Dissolve 0.3 g of sulphanillic acid in 50 ml of 2M hydrochloric acid, add 3 g of KBr, cool in ice and titrate with 0.1 M sodium nitrite Vs determining the end-point amperometrically. Each ml of 0.1 N sodium nitrite Vs is equivalent to 17.32 mg of $C_6H_7NO_3S$.

Procedure : Dissolve 0.25 g of procainamide hydrochloride in 50 ml of 2 M hydrochloric acid, add 3 g of potassium bromide, cool in ice and titrate slowly with 0.1 M sodium nitrite Vs, stirring constantly and determining the end-point amperometrically. Each ml of 0.1 M sodium nitrite Vs is equivalent of 27.18 mg of $C_{13}H_{21}N_3O \cdot HCl$.

17.4.2. COGNATE ASSAY

Procaine hydrochloride can be assayed exactly in a similar manner by using 0.4 g of the substance. Each ml of 0.1 M sodium nitrite Vs is equivalent to 27.28 mg of $C_{13}H_{20}N_2O_2, HCl$.

17.4.3. ASSAY OF NICKEL WITH DIMETHYLGLYOXIME

Materials Required : 0.001 M Nickel solution ; supporting electrolyte [a mixture of NH_4OH (1.0 M) and NH_4Cl (0.2 M)] ; gelatin solution (0.2%) : 2 ml ;

Procedure : The following steps may be followed in a sequential manner :

1. Weigh accurately a sample of Ni-salt to yield a 0.001 M Ni-solution. To 25 ml of this solution placed in a titration cell add an equal volume (25.0 ml) of a supporting electrolyte and 2 ml of gelatin solution,
2. The solution must be deoxygenated. Set the applied e.m.f. to 01.85 V Vs SCE (standard-calomel electrode),
3. The diffusion current is measured, and
4. Finally, titrate with dimethylglyoxime solution (0.02 M) using the standard general method and obtain a V-shaped graph.

Each ml of dimethylglyoxime solution is equivalent to 0.5869 mg of Nickel.

17.4.4. ASSAY OF LEAD WITH POTASSIUM DICHROMATE SOLUTION

Materials Required :

- (i) **Buffered supporting electrolyte :** Dissolve 10 g of KNO_3 and 8.2 g of sodium acetate in 500 ml of DW. Add glacial acetic acid carefully until a pH of 4.2 is achieved (pH Meter) (approximately 10 ml of the acid will be required),
- (ii) **Standard 0.01 M $K_2Cr_2O_7$ Solution :** Weigh accurately 'ANALAR'-grade 1.47 g $K_2Cr_2O_7$ into a 500-ml volumetric flask. Dissolve in DW and make up the volume upto the mark, and
- (iii) **0.1% w/v Gelatin Solution :** Dissolve 0.1 g gelatin in 100 ml of boiling DW.

Procedure : The amperometric titration may be carried out in a 100 ml beaker. A saturated KNO_3 salt bridge is employed to provide contact between the saturated calomel electrode and the analyte solution. The various steps involved are as follows :

1. Weigh accurately a sample of Pb-salt to give a 0.01 to 0.02 M lead solution,

2. Transfer 10.0 ml aliquot to the titration vessel,
3. Add to it 25 ml of the buffered supporting electrolyte, and 5 ml of the gelatin solution,
4. Determine the current at zero applied potential,
5. Add $K_2Cr_2O_7$ (0.01 M) solution, in 1 ml increments, and measuring the resulting current after each addition,
6. Continue the addition to at least 5.0 ml beyond the equivalence point,
7. Correct the currents for the volume change, and plot the graph. Determine the end-point and calculate the number of milligrams of Pb in the given sample, and
8. Repeat the titrations at -1.0 V. It is essential to bubble N_2 through the solution for 10–15 minutes before the titration and while addition of reagents are made. However, the flow of N_2 must be stopped at the time of measuring the current. Again, correct the currents for dilution, plot the graph, determine the end-point, and report the number of milligrams of Pb present in the given sample.

THEORETICAL AND PRACTICAL EXERCISES

1. (a) Give a plausible explanation of the theoretical aspects of ‘**amperometric method**’ of analysis with specific reference to both Fick’s Law and Nernst Equation.
(b) Give a brief account of the various salient features of ‘**amperometry**’.
2. Discuss the four typical amperometric titration curves obtained in amperometric method of analysis and examine them critically with appropriate examples.
3. Attempt the following with regard to ‘**amperometry**’ :
(a) Corrections for the volume change, and
(b) Advantages.
4. What are the **three** methods to accomplish amperometric titrations effectively. Describe any ONE method exhaustively with its diagram, components and working. Enumerate briefly the advantages of one such method over the other.
5. How would you assay the following medicinal compounds amperometrically :
(i) Procaine hydrochloride, (ii) Procainamide hydrochloride,
(iii) Presence of Ni with dimethylglyoxime, and (iv) Presence of Pb with $K_2Cr_2O_7$ solution.

RECOMMENDED READINGS

1. Bard, A.J. Ed., **Electrochemical Chemistry : A Series of Advances**, New York, Marcel Dekker, 1966.
2. Bard, A.J. and R.L. Faulkner, **Electrochemical Methods**, New York, John Wiley & Sons. Inc., 1980.
3. Vassos, B.H. and G.W. Ewing., **Electroanalytical Chemistry**, New York, Wiley, 1983.
4. Kissinger, P.T. and W.R. Heineman, **Laboratory Techniques in Electroanalytical Chemistry**, New York, Marcel Dekker, 1984.
5. **Wilson and Wilson’s Comprehensive Chemistry**, Vol. XXII, Amsterdam, Elsevier Science, 1986.
6. Rieger, P.H., **Electrochemistry**, Englewood Cliffs NJ, Prentice Hall, 1987.
7. Kalvoda, R., **Electroanalytical Methods in Chemical and Environmental Analysis**, New York, Plenum, 1987.

PART IV
OPTICAL METHODS

**This page
intentionally left
blank**

18

REFRACTOMETRY

CONTAINS :

- 18.1 Introduction
- 18.2 Theory
- 18.3 Instrumentation
- 18.4 Determination of refractive index of pharmaceutical substances
- 18.5 Applications of refractivity

18.1. INTRODUCTION

Light passes more rapidly through a vacuum than through a substance (medium). It has been observed that when a ray of light happens to pass from one medium (*a*) into another medium (*b*) it is subjected to refraction (Figure 18.1). In other words, the ray travels at a lower velocity in the relatively more optically dense medium (*b*) than in medium (*a*) which is less optically dense. It is a common practice to compare the refractive indices of liquids to that of air.

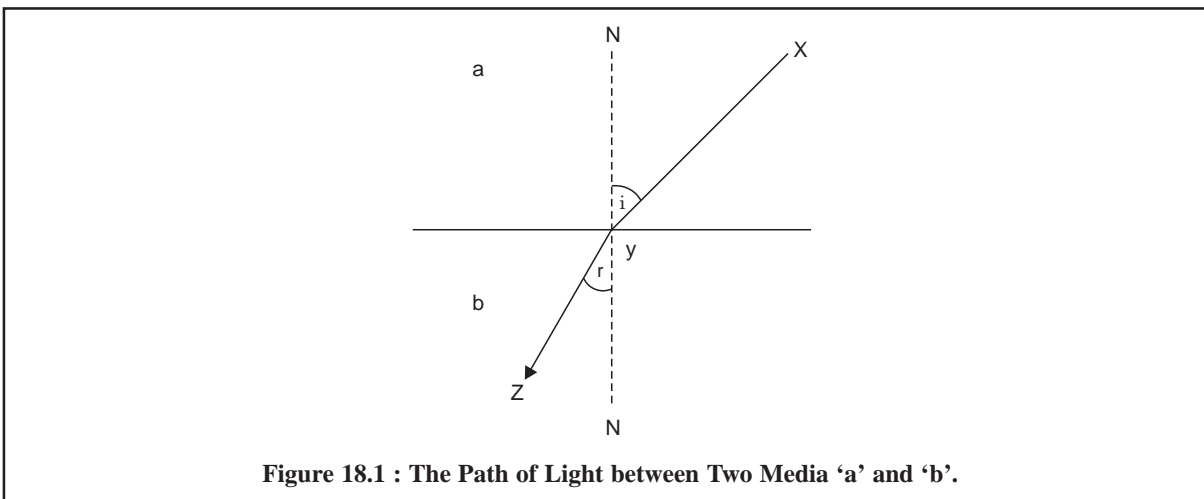

Figure 18.1 : The Path of Light between Two Media 'a' and 'b'.

According to Snell's Law we have :

$$a^n b = \frac{\sin i}{\sin r} \quad \dots(1)$$

where, i = Angle of incidence,

r = Angle of refraction, and

n = Refractive index of medium (*b*) relative to medium (*a*)

Critical Angle *vis-a-vis* Refractive Index

Figure 18.2, represents the critical angle which is used invariably in refractometry. Considering a narrow band of rays, x - y , held near to the boundary between the two media '*a*' and '*b*' (Figure 18.2), and

viewed at Z, one may observe a band of light. This particular band has a sharp edge at y, where the actual ray (y-y) may be seen. However, no rays are to be seen in the y-y' region. Therefore, we have :

$$a^n b = \frac{\sin i}{\sin r} = \frac{\sin 90^\circ}{\sin \theta} = \frac{1}{\sin \theta} \quad \dots(2)$$

Thus, a measurement of the critical angle θ may ultimately offer the exact refractive index of medium (b).

It is pertinent to mention here that the refractive index of a substance is not a static (constant) property of the substance but it alters with (a) wavelength and (b) temperature.

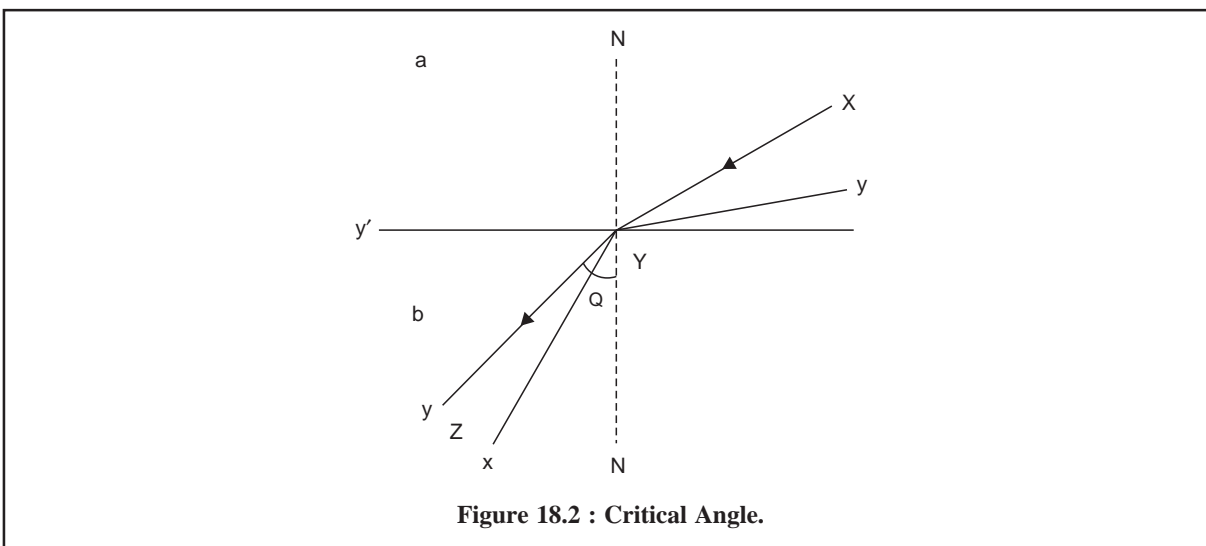

Figure 18.2 : Critical Angle.

Therefore, conventionally the temperature at which the refractive index is measured is usually designated as a superscript numerical on n ; whereas the wave-length of light employed as a subscript capital. Thus, we have : n_D^{20} , where 20 specifies the temperature expressed in ($^{\circ}\text{C}$) at which RI has been measured and D represents the sodium D-light ($\lambda = 589.3 \text{ nm}$).

18.2. THEORY

Lorentz and Lorentz in 1880, introduced the terminology **specific refraction** or **refractivity** which may be expressed as :

$$[n] = \frac{n^2 - 1}{n^2 + 2} \cdot \frac{1}{p} \quad \dots(3)$$

where, n = Refractive index,

p = Density of the substance*

Hence, the specific refraction (Eq. 3) is considered to be a more useful property and is characteristic of the substance, being absolutely independent of temperature.

Molar Refractivity : Later on, a still more useful property termed as the molar refraction (or refractivity) was introduced which could be expressed as follows :

$$R = \left(\frac{n^2 - 1}{n^2 + 2} \right) \frac{M}{p} \quad \dots(4)$$

*Density measured at the same temperature as the refractive index RI

where, R = Molar refraction,

P = Density of the substance, and

M = Molecular weight.

Interestingly, both specific refraction $[n]$ and molar refraction (R), being temperature independent, should have the same values for a given substance either in the solid, liquid or gaseous state, provided the molecular structure is unchanged.

Unit of Molar Refraction : As the refractive index is a dimensionless quantity, the units of molar refraction are simply those of molar volume, M/p *i.e.*, $\text{cm}^3 \cdot \text{mol}^{-1}$.

The molar refractivity is more or less an additive property.

Atomic Refractivities : Atomic refractivities may be attributed by virtue of :

- Structural features *e.g.*, double bond, triple bond or nature of ring structure (3-member/4-member rings), and
- Individual atoms, *e.g.*, H, C, Cl, Br, I and O. However, 'O' contributes different values for different groups, for instance : hydroxyl ($-\text{OH}$), carbonyl ($-\text{CO}-$) and ethereal ($-\text{O}-$) moieties.

A few representative atomic refractivities and bond contributions are given in Table 18.1 below :

Table 18.1 : Atomic Refractivities for Na D-Light ($\lambda = 589.3 \text{ nm}$)

Atom	R ($\text{cm}^3 \text{ mol}^{-1}$)
H	1.100
C	2.418
C (C = C)	1.733
C (C \equiv C)	2.398
O ($-\text{OH}$)	1.525
O ($-\text{CO}-$)	2.11
O ($-\text{O}-$)	1.643
Cl	5.967
Br	8.748
I	13.900
3-Member Ring	0.71
4-Member Ring	0.48

Based on the atomic refractivities given in Table 18.1, it may be possible to calculate the molar refractivities of various pharmaceutical substances theoretically and compare the same with values found experimentally. A few typical examples are cited below :

(a) **Acetone, CH_3COCH_3 [or $\text{C}_3\text{H}_6\text{O}$]:**

$$\begin{aligned} R_{\text{C}_3\text{H}_6\text{O}} &= 3 R_{\text{C}} + 6R_{\text{H}} + R_{\text{O}} \\ &= 3 \times 2.418 + 6 \times 1.100 + 2.211 \\ &= \mathbf{7.254 + 6.600 + 2.11 = 15.964} \end{aligned}$$

$$\text{Calculated : } R_{\text{C}_3\text{H}_6\text{O}} = 15.964 \text{ cm}^3 \text{ mol}^{-1}$$

$$\text{Experimental : } R_{\text{C}_3\text{H}_6\text{O}} = 15.985 \text{ cm}^3 \text{ mol}^{-1}$$

(b) **Methyl Alcohol, CH₃OH [or CH₄O] :**

$$\begin{aligned} R_{\text{CH}_3\text{OH}} &= R_{\text{C}} + 4R_{\text{H}} + R_{\text{O}} \\ &= 2.418 + 4 \times 1.100 + 1.525 \\ &= 2.418 + 4.400 + 1.525 \\ &= \mathbf{8.343} \end{aligned}$$

$$\text{Calculated : } R_{\text{CH}_4\text{O}} = 8.343 \text{ cm}^3 \text{ mol}^{-1}$$

$$\text{Experimental : } R_{\text{CH}_4\text{O}} = 8.296 \text{ cm}^3 \text{ mol}^{-1}$$

(c) **Chloroform CHCl₃ :**

$$\begin{aligned} R_{\text{CHCl}_3} &= R_{\text{C}} + R_{\text{H}} + 3R_{\text{Cl}} \\ &= 2.418 + 1.100 + 3 \times 5.967 \\ &= 2.418 + 1.100 + 17.901 \\ &= \mathbf{21.419} \end{aligned}$$

$$\text{Calculated : } R_{\text{CHCl}_3} = 21.419 \text{ cm}^3 \text{ mol}^{-1}$$

$$\text{Experimental : } R_{\text{CHCl}_3} = 21.393 \text{ cm}^3 \text{ mol}^{-1}.$$

18.3. INSTRUMENTATION

In Figure 18.3, the optical system of **Abbe' Refractometer** has been shown based on the critical angle principle.

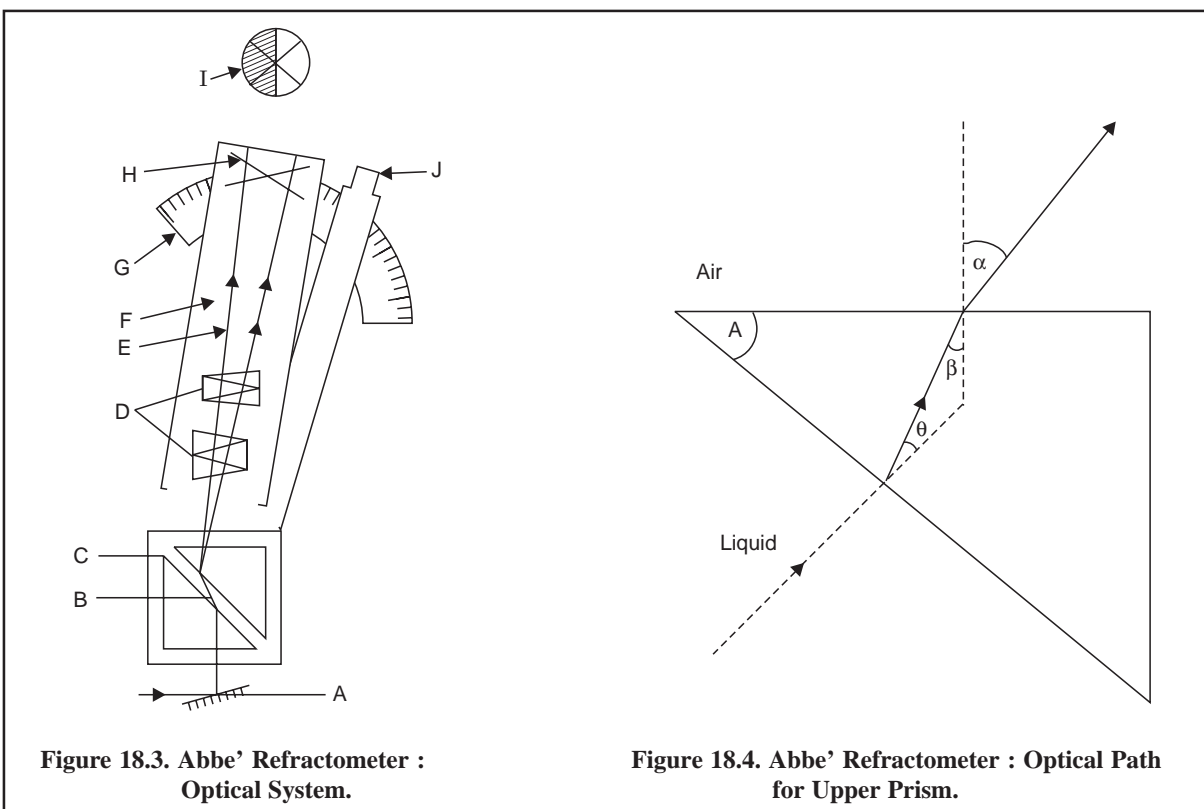

Figure 18.3. Abbe' Refractometer :
Optical System.

Figure 18.4. Abbe' Refractometer : Optical Path
for Upper Prism.

The various parts in Figure 18.3, are stated as below :

A = Mirror ;	F = Telescope ;
B = Liquid (Sample) ;	G = Scale ;
C = Prism box ;	H = Cross hair ;
D = Amici Prisms ;	I = Field of view ;
E = Critical ray ;	J = Eye-piece for reading scale ;

Procedure : The liquid whose RI is to be determined is placed between the two prisms (B). The upper face of the lower prism has a ground surface so as to diffuse the light rays in every possible direction. The rays passing from the liquid to the upper prism undergoes refraction in the normal manner, thereby providing a bright field in the eye-piece. The critical ray is originated by virtue of the rays that strike the liquid glass interface at the grazing incidence. As an outcome of these combined effects the '*field of view*' is represented as a distinct dark and light area having a sharp dividing line.

Fig. 18.4, designates the optical path for the upper prism in Abbe' Refractometer. When a ray of light passes from the liquid medium and enters the upper prism, it gets refracted by an angle θ between the lower face of the prism and the normal, an angle β between the emerging refracted ray at the upper face and the normal, and finally an angle α between the reflected ray at the upper face and the normal. Thus, we have :

$$N = \frac{\sin \alpha}{\sin \beta} \quad \dots(a)$$

$$\sin \theta = \text{glass } n \text{ liquid} = \frac{n}{N} \quad \dots(b)$$

where, N = Refractive index of the prism compared to air, and

n = Refractive index of the liquid (air to liquid)

and $A = \beta + \theta$

or $\theta = A - \beta \quad \dots(c)$

From Eq. (b) we have :

$$n = N \sin \theta \quad \dots(d)$$

Putting the value of θ from Eq. (c) in Eq. (d), we have :

$$n = N \sin (A - \beta)$$

or $n = N \sin A \cos \beta - N \cos A \sin \beta \quad \dots(e)$

As we know $\sin^2 \beta + \cos^2 \beta = 1 \quad \dots(f)$

From Eq. (a) we have :

$$N^2 = \frac{\sin^2 \alpha}{\sin^2 \beta}$$

or $\sin^2 \beta = \frac{\sin^2 \alpha}{N^2} \quad \dots(g)$

From Eqs. (f) and (g) we may have :

$$\frac{\sin^2 \alpha}{N^2} + \cos^2 \beta = 1$$

or $\cos \beta = \sqrt{\left\{1 - \frac{\sin^2 \alpha}{N^2}\right\}} \quad \dots(h)$

Substituting the value of $\cos \beta$ from Eq. (h) in Eq. (e) and also $\sin \beta = \sin \alpha/N$ from Eq. (a) we have :

$$n = N \sin A \sqrt{\left\{1 - \frac{\sin^2 \alpha}{N^2}\right\}} - \cos A \sin \alpha$$

or
$$n = \left\{\sin A \sqrt{(N^2 - \sin^2 \alpha)}\right\} - \sin \alpha \cos A \quad \dots(i)$$

Now, based on the two constants, viz., A and N, for a specific prism and a measurable angle α it is convenient to determine the refractive index of the liquid n relative to air from Eq. (i). With the help of the Abbe' refractometer the angle α lying between the normal and the critical ray emerging from the upper surface of the prism may be measured. By the aid of the two constants A and N (for a particular prism) the angle α has been converted into the refractive index directly and the scale of the instrument has been duly calibrated and printed accordingly.

The telescope (F) of the Abbe' refractometer is fixed (Figure 18.3) and the prism box (C) is directly attached to the scale. When C is made to rotate gradually the critical ray (E) falls on the cross hair (H) of the telescope (F). At this juncture the value of the refractive index of the liquid (n) can be measured directly from the scale (G).

It is, however, important to mention here that the calibration of Abbe's refractometer may be checked periodically by making use of standard liquids whose refractive index are stated in the *European Pharmacopoea* (as Reference Liquids).

For instance

S.No.	Standard Liquid	Refractive Index*
1.	Carbon Tetrachloride	1.4603
2.	α -Methylnaphthylamine	1.6176
3.	Toluene	1.4969

18.4. DETERMINATION OF REFRACTIVE INDEX OF PHARMACEUTICAL SUBSTANCES

A large number of pharmaceutical substances such as volatile oils, namely : peppermint oil, lemon oil, aniseed oil have a definite range of refractive index. Based on this physical characteristic it is possible to ascertain the purity of this volatile oil precisely and accurately.

Materials Required : Abbe' refractometer, volatile oil, xylene, capillary tubes ;

Procedure : In order to obtain precise and accurate measurements the prism case of Abbe' refractometer is attached to a thermostat bath whose temperature is previously maintained at 25°C. Open the prism box gently and place a few drops of pure volatile oil on the lower prism with the help of a capillary tube and finally close the box. The mirrors are duly adjusted so as to obtain a bright illumination of the field of view. The knurled knob is turned gradually until the field of view displays a dark and light zone. In case, a coloured-fringe is observed between the two zones it becomes necessary to adjust the Amici prisms carefully to achieve a sharp and black boundary. It is important to adjust this on the cross hair and finally the reading of refractive index is noted. After use, the prism box is opened and cleaned thoroughly with a lens cleansing tissue moistened with xylene/acetone. Thus, the refractive index, n_D^{25} for certain volatile oils as per BP (1993) are as follows :

*European Pharmacopoea Reference Liquids

Peppermint oil	:	1.460—1.467
Lemon oil	:	1.474—1.476
Aniseed oil	:	1.553—1.560
Clove oil	:	1.528—1.537
Dill oil	:	1.481—1.492
Eucalyptus oil	:	1.458—1.470

18.5. APPLICATIONS OF REFRACTIVITY

The various applications of refractivity are enumerated below :

- (a) It is feasible to determine the molar refractivities of different substances experimentally and subsequently comparing their values with theoretical ones as discussed in section 18.2,
- (b) Based on the fact that molar refractivity is an additive property, it may be utilized to determine the refractivities of homogeneous mixtures (as solutions).

Thus, the molar refraction of a solution having two components (*viz.*, the solute and the solvent) is given by the expression :

$$R_{1,2} = N_1R_1 + N_2R_2 \quad \dots(i)$$

where, N_1 = Mole fraction of the solute,

N_2 = Mole fraction of the solvent,

R_1 = Molar refractivity of the solute, and

R_2 = Molar refractivity of the solvent.

Evidently, from Eq. (i), it is quite possible to determine the molar refractivity of an unknown solute R_1 provided we know the mole fraction N_1 and N_2 and the refractivities of the solute R_2 and the homogeneous solution $R_{1,2}$.

Besides, the concentration of the solute in the solution may be determined by employing the following expression, provided the refractivities of the solute, the solvent and the solution are known :

$$R_{1,2} = \frac{(n^2 - 1)}{(n^2 + 2)} \left[\frac{N_1M_1 + N_2M_2}{\rho} \right] \quad \dots(ii)$$

(c) Determination of Critical Micelle Concentration (CMC)

In general, substances that form micelles in water offer two distinct regions in their molecules : first, the hydrophobic entity (caused due to the hydrocarbon chain), and secondly, the hydrophilic entity (caused due to the polar group). It has been observed that a number of monomers usually hold all the hydrocarbon chains together specifically in the centre of the micelle which are ultimately responsible for minimising the free energy of the system. Thus, the particular concentration at which the micelles are first observed is termed as the **critical micelle concentration (CMC)**. Interestingly, the physical characteristics of the substances forming micelles afford sharp changes at the CMC. Therefore, a plot of refractive index (RI) Vs concentration (g/L) must depict a visible change in slope at the CMC.

Example :

Determination of critical micelle concentration (CMC) of Butyric Acid by refractometry :

Butyric acid ($\text{CH}_3\text{CH}_2\text{CH}_2\text{COOH}$) is found to form micelles in an aqueous medium in a concentration range fairly suitable for measurements with the Abbe' refractometer.

Materials Required : Butyric acid solution (25%, w/v in DW) : 200 ml ; volumetric flasks (50 ml) : 6 ;

Procedure : Prepare precisely 2.5, 5.0, 7.5, 10.5, 15.0 and 20.0% solutions of butyric acid in water by measuring suitable volumes (from a stock solution of 25% w/v) with the help of a burette into six 50 ml volumetric flasks, and finally making up the volume with DW. Using Abbe' refractometer measure the refractive indices of all the above six solutions besides the stock solution (25%) at 25°C. Measure also the refractive index of DW.

Results : Plot a graph having the various concentrations of butyric acid along the abscissa and the refractive indices along the ordinate, whereby two straight lines are obtained intersecting at the CMC as shown in Figure 18.5 below :

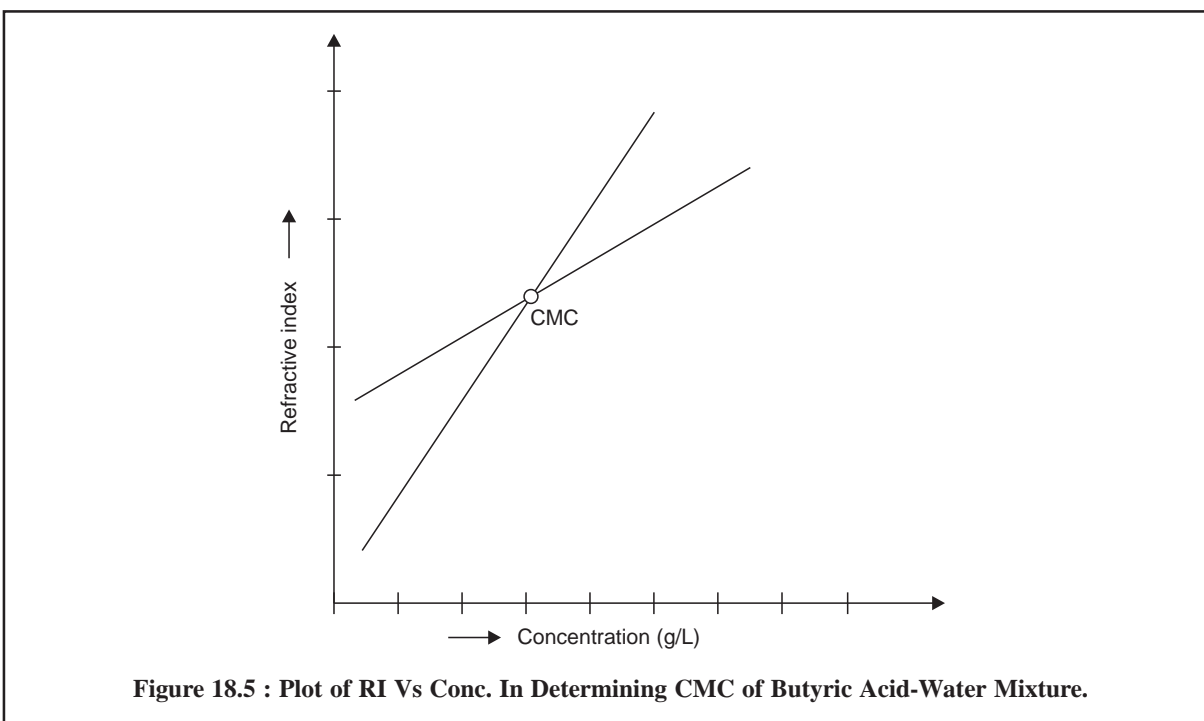

THEORETICAL AND PRACTICAL EXERCISES

1. Explain the following with reference to 'Refractometry' :
 - (a) Snell's Law,
 - (b) Critical angle *vis-a-vis* Refractive index,
 - (c) Molar refractivity, and
 - (d) Atomic refractivities.
2. Describe the optical system of Abbe's Refractometer, its optical path for upper prism and its operational procedure.
3. How would you derive the mathematical expression ' n ' *i.e.*, the refractive index ?
4. How would you determine the 'refractive index' of pharmaceutical substances ? Give suitable examples.
5. Discuss the applications of refractivity with special reference to Critical Micelle Concentration (CMC).

RECOMMENDED READINGS

1. Glasstone, S., **'Textbook of Physical Chemistry'**, New York, D. Van Nostrand, 1960.
2. Barrow, G.M., **'Physical Chemistry'**, New York, McGraw Hill, 1961.
3. Nachod, F.C. and J.J. Zuckerman, Eds., **'Determination of Organic Structures by Physical Methods'**, New York, Academic Press, 1971.
4. Weissberger, A and B.W. Rossiter, **'Techniques of Chemistry', Vol. I : Physical Methods of Chemistry**, New York, John Wiley & Sons Inc., 1972.

19

POLARIMETRY

- 19.1 Introduction
- 19.2 Theory
- 19.3 Instrumentation
- 19.4 Determination of optical activity of pharmaceutical substances
 - 19.4.1 Determination of optical rotation of pharmaceutical substances
 - 19.4.2 Determination of specific optical rotation of pharmaceutical substances

19.1. INTRODUCTION

The classical electromagnetic theory of light put forward by Maxwell advocates that the electric and magnetic fields associated with a beam of monochromatic light vibrate in all directions perpendicular to the direction of propagation of light. In fact, there exists an indefinite number of planes that pass through the line of propagation, and an ordinary light usually vibrates in all the planes. This is also referred to as **unpolarized light**. Under certain specific circumstances, the vibrations may all be restricted to one direction only, in the perpendicular plane and this is termed as **plane-polarized light**.

Figures 19.1 (a) and (b) depict the ordinary or unpolarized light and plane-polarized light respectively.

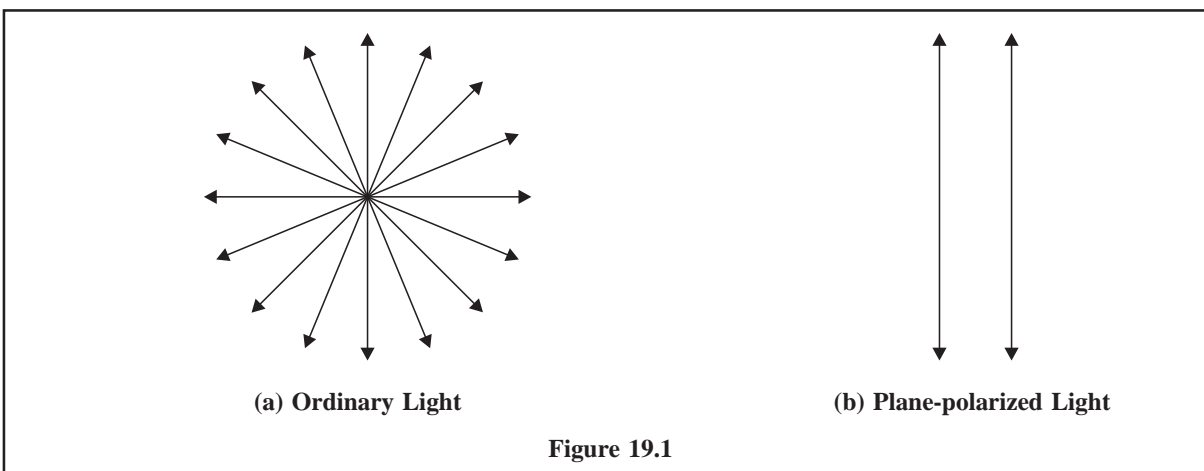

A few crystalline substances, for instance : Iceland spar, Calcite (a form of CaCO_3) or Polaroid, possess different refractive indices for light whose field oscillates either perpendicular or parallel to the principal plane of the crystal. Thus, an ordinary light (unpolarized light) gets converted into a plane-polarized light by simply passing it through a lens made of the above cited materials and traditionally called a **Nicol prism** (after **William Nicol-the inventor**).

Therefore, an optically active substance is one that rotates the plane of polarized light. In other words, certain specific substances by virtue of their internal structure may be able to transmit only such vibrations that are oriented along certain directions and entirely block vibrations in other directions.

Figure 19.2 evidently shows the electric field of a plane-polarized light which consists of two components of fixed magnitude rotating in opposite directions to one another ; the right circularly polarized light ; and the

left circularly polarized light. However, it is worth mentioning that the plane-polarized beam is the vector-sum of these two components.

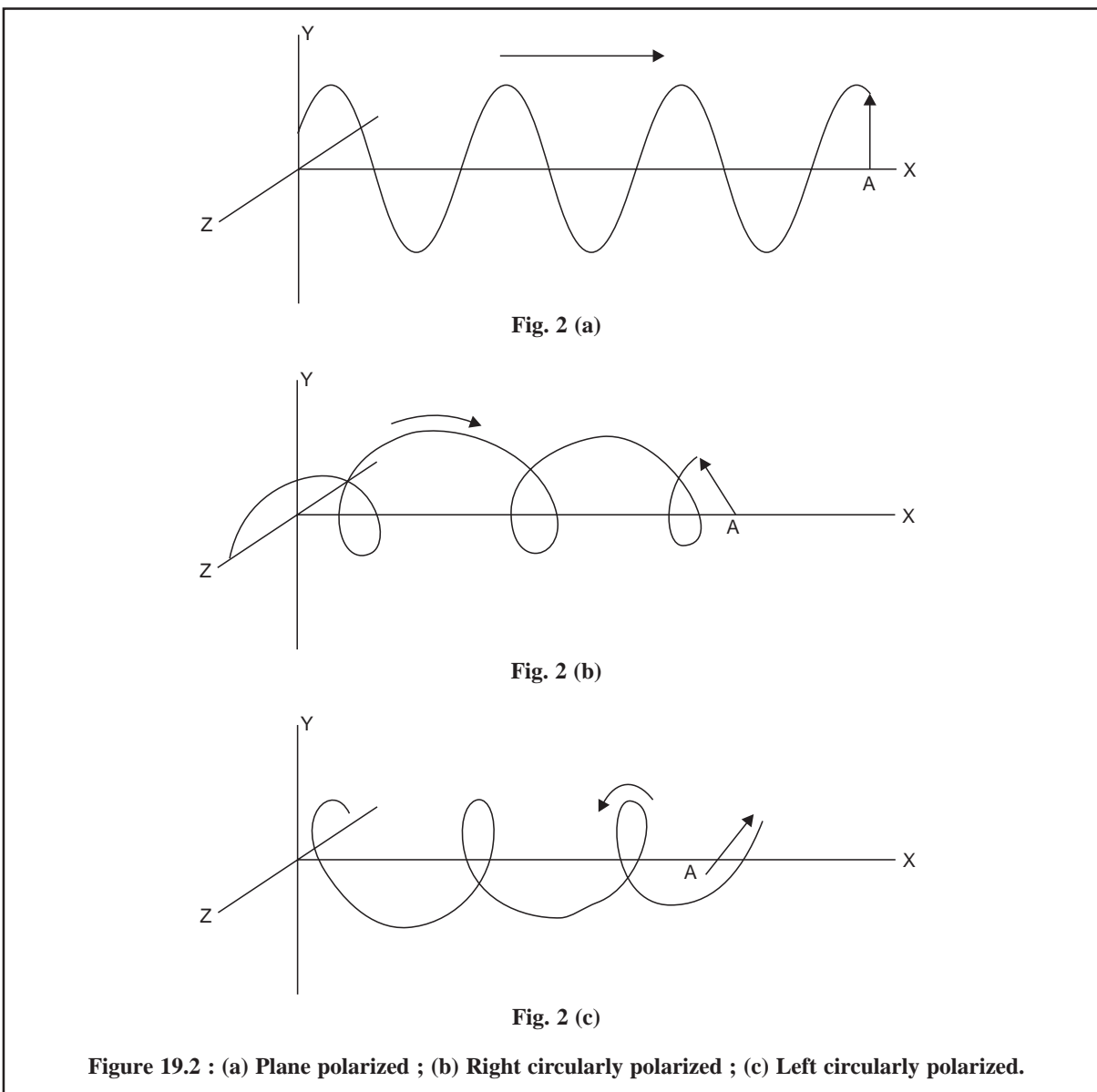

19.2. THEORY

An **optically active substance is one that rotates the plane of polarized light**. In other words, when a polarized light, oscillating in a specific plane, is made to pass through an optically active substance, it happens to emerge oscillating in an altogether different plane.

In general, organic molecules having a central carbon atom to which are attached four altogether different moieties, as C (WXYZ) thereby rendering the molecule asymmetric, are all optically active. Such types of molecules usually exist in two stereoisomeric forms as mirror images of each other. For example :

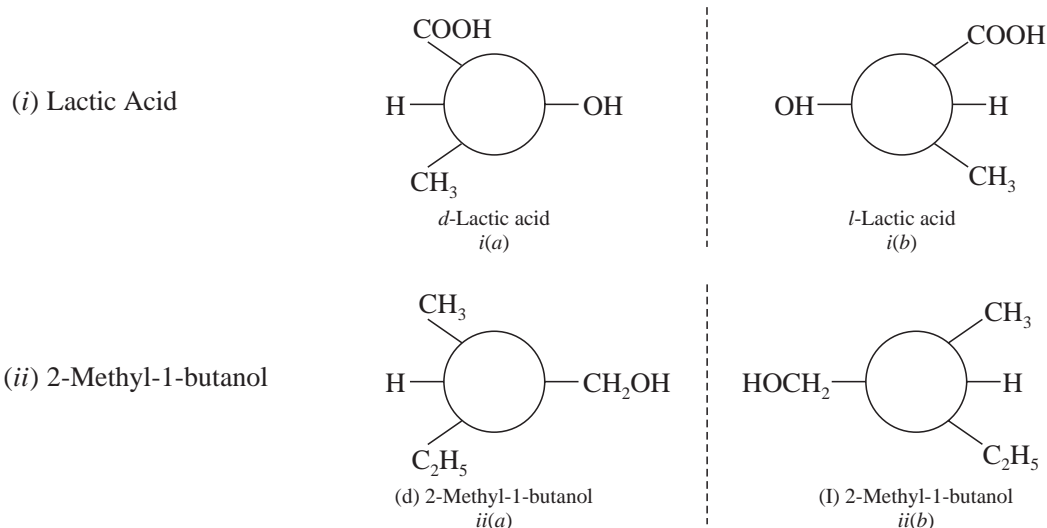

In the above cited example [*i (a)*] the rotation of the plane of polarization is to the right (clockwise), the lactic acid is dextrorotatory (Latin : *dexter* = right) designated by '*d*'; if the rotation is to the left (counterclockwise), the lactic acid [*i (b)*] is levorotatory (Latin : *laevus* = left) designated by '*l*'. In the same vein, the example [*ii (b)*] represents 1-2 methyl-1-butanol ; a product derived from fusel oil.

Non-superimposability and Optical Activity : Interestingly, in these two specific examples of lactic acid (*d*- ; and *l*-isomers) and 2-methyl-1-butanol (*d*- ; and *l*-isomers) one criterion is common *i.e.*, the two mirror images are not superimposable. In other words, such compounds whose mirror images display non-superimposability exhibit optical activity. Furthermore, in the particular instance of C (WXYZ) it may be observed that the molecule whose mirror-image is not just another identical molecule but gives rise to a molecule of an altogether different isomeric compound. Thus, a pure sample of a single enantiomer must fulfil the following *three* important characteristic features, namely :

- (*a*) No molecule can serve as the mirror image of another molecule,
- (*b*) Exact cancelling out of rotations (of plane of polarized light) do not occur, and
- (*d*) Net result is offered in terms of the '*optical activity*'.

Superimposability and Loss of Optical Activity : In a situation where molecules exist as C (W_2XY), that is when two of the four groups become identical, as may be observed in bromochloromethane and isopropylchloride as shown below :

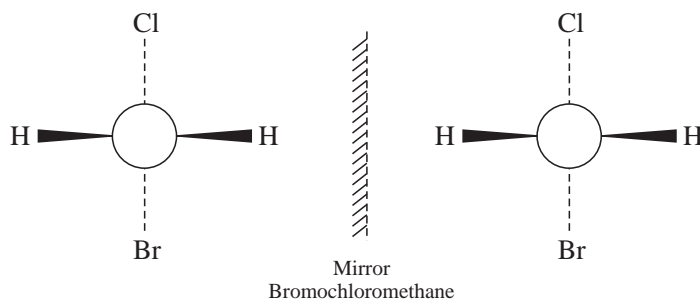

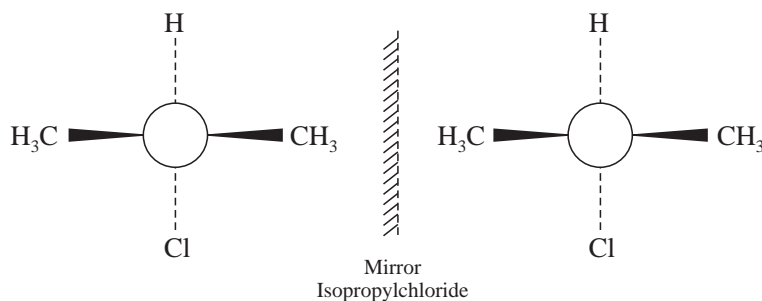

It may be observed clearly that the two mirror images are superimposable and hence they do not exhibit any optical activity.

19.3. INSTRUMENTATION

The rotation of the plane of polarized light and hence the optical activity may be detected and measured accurately by an instrument known as the polarimeter.

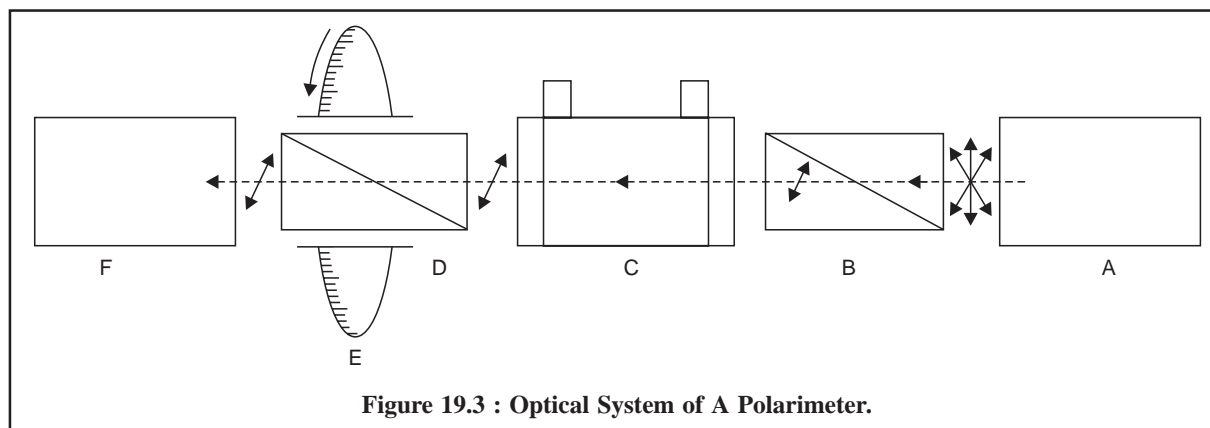

Figure 19.3, represents the optical system of a polarimeter,

A = Collimated monochromatic light source,

B = Polarizing prism (Nicol),

C = Polarimeter glass tube (20 cm) with glass windows,

D = Analyzing rotator prism (Nicol),

E = Circular scale with vernier,

F = Null detector (Eye or Photoelectric Cell).

Principle : The underlying principle of a polarimeter is that light from the source, usually a sodium vapour lamp, first gets collimated at A, and subsequently falls upon polarizer B (a **calcite prism**). The polarizer permits only the light polarized in a particular direction to pass it. The emergent polarized ray now passes through the sample under investigation, kept in the polarimeter glass tube C to the analyzer D, which happens to be another polarizing prism. The analyzing rotator prism D (**Nicol**) is fixed in such a manner that it can be rotated easily about the axis of the incident light ray. Two situations arise when the analyzing rotator prism (D) is put into action, *firstly*, the prism being parallel to the plane of polarization of the incident light—the net result is that the intensity of light reaching the Null detector F is maximum ; and *secondly*, the prism being perpendicular to the plane of the polarized light—the net result is observed by the intensity of light reaching the detector as minimum. Hence, the overall difference in the position of the analyzer, as noted from the circular

scale E, that provides minimum light intensity with and without the sample in the cell is the observed 'rotation' of the sample in question.

Specific Rotation : A polarized light when passed through an optically active substance, each molecule of it encountered by the light beam rotates the plane of polarization by a constant amount characteristic of the substance. Consequently, a measure of the rotary power of the individual molecule, irrespective of the two parameters, namely : the path length and the concentration, is achieved by converting the measured rotation into a specific rotation by the help of the following expressions :

$$[\alpha]_{\lambda}^T = \frac{100 \alpha_{\lambda}^T}{LC} \quad \dots(a)$$

or

$$= \frac{\alpha_{\lambda}^T}{L\rho} \quad \dots(b)$$

where, T = Temperature (°C),

λ = Wavelength (= D is used to denote the sodium D line, which is a doublet at 5890° A),

$[\alpha]_{\lambda}^T$ = Specific rotation at temperature T and wavelength λ ,

L = Length of the path of the light through the sample in decimeters,

C = Concentration of the optically active substance (in grams per 100 ml of solution),

α_{λ}^T = Observed angle of rotation, and

ρ = Density of the substance.

19.4. DETERMINATION OF OPTICAL ACTIVITY OF PHARMACEUTICAL SUBSTANCES

The two characteristic parameters related to optical activity of the pharmaceutical substances, namely : (a) optical rotation, and (b) specific optical rotation, can be measured satisfactorily by the help of a Polarimeter as stated below :

19.4.1. DETERMINATION OF OPTICAL ROTATION OF PHARMACEUTICAL SUBSTANCES

The optical rotation of a number of pure pharmaceutical substances may be measured accurately by noting the angle through which the plane of polarization is rotated when polarized light passes through the substance, if liquid or through a solution of the substance, if solid.

A few typical examples of ibuprofen and levodopa are discussed below :

19.4.1.1. Ibuprofen

Materials Required : 2.5% (w/v) solution of ibuprofen and a polarimeter ;

Procedure : First and foremost it is absolutely necessary to check the linearity of the scale of a polarimeter either using **certified quartz plates** or using **known solution of sucrose**.

The sample tube of the polarimeter is rinsed with the drug solution (2.5% w/v) and filled up with the same solution. The end glass-windows are closed properly. The angle of rotation of ibuprofen is now measured at 19.5° to 20.5°, using the D-line of polarized sodium light. Take at least five measurements and determine the mean value.

19.4.1.2. Levodopa

Theory : It has been observed that the specific rotation of levodopa in the visible region is rather on the lower side *i.e.*, ($[\alpha]_D^{20} = -12^\circ$ in 1 M hydrochloric acid). Therefore, it is necessary to enhance the optical

rotation to a reasonable extent by some suitable means. It is, however, achieved by the formation of a complex with hexamine.

Materials Required : Dried levodopa : 0.2 g ; hexamine : 5.0 g ; hydrochloric acid (1 M) : 50 ml (dissolve 85 ml of HCl in 1 L of DW) ;

Procedure : Dissolve a quantity equivalent of 0.2 g of the dried substance and 5 g of hexamine in 10 ml of 1 M hydrochloric acid, add sufficient 1 M HCl to produce 25 ml and allow to stand for 3 hours, protected from light. The optical rotation is measured by a previously calibrated polarimeter.

Optical Rotation : -1.27° to -1.34°

19.4.1.3 Cognate Assays

The optical rotation of a number of substances official in the pharmacopoeia may be determined conveniently as stated in Table 19.1.

Table 19.1 : Optical Rotation of Some Official* Compounds

S.No.	Substance	Conc. Used (% w/v)	Length of Tube (dm)	Optical Rotation	Remarks
1.	Atropine Methobromide	10	2	-0.25° to $+0.05^{\circ}$	—
2.	Atropine Methonitrate	10	2	-do-	—
3.	Atropine Sulphate	10	2	-0.50° to $+0.05^{\circ}$	—
4.	Racemic Camphor	10 (in 96 % EtOH)	—	-0.15° to $+0.15^{\circ}$	—
5.	Dihydrotachysterol	—	—	$+70^{\circ}$ to $+80^{\circ}$	—
6.	Lemon Oil	—	—	$+57^{\circ}$ to $+70^{\circ}$	—
7.	Dementholised Mint Oil	—	—	-22° to -29° -17° to -24°	Brazilian Oil, Chinese Oil
8.	Orange Oil	—	—	$+94^{\circ}$ to $+99^{\circ}$	—
9.	Spearmint Oil	—	—	-45° to -60°	—

19.4.2 DETERMINATION OF SPECIFIC OPTICAL ROTATION OF PHARMACEUTICAL SUBSTANCES

The **specific optical rotation** of a solid substance is usually determined by measuring the angle of rotation at the wavelength of the sodium D-line at a temperature of 20°C , and calculating the result with reference to a layer 1 dm thick of a solution containing 1 g of the substance per ml. It is pertinent to mention here that the specific optical rotation of a solid is always expressed to a given solvent and concentration.

Example : Adrenaline ;

19.4.2.1. Adrenaline

Theory : As pure adrenaline is sparingly soluble in distilled water, therefore, its solution is made in 1 M hydrochloric acid whereby the N-atom gets protonated and results into the formation of a quaternary ammonium compounds as shown in under :

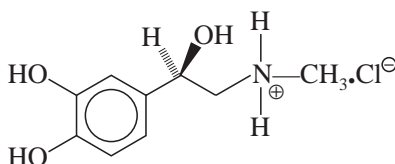

*British Pharmacopoeia, 1993.

Materials Required : 4% w/v solution of adrenaline in 1 M HCl (dissolve 85.0 ml of HCl in 1 L of DW) ;

Procedure : Determine the angle of rotation of the freshly prepared 4% w/v solution of adrenaline in 1 M hydrochloric acid with the help of a previously checked polarimeter. The mean value of at least five similar determinations is employed in the calculation of the specific optical rotation.

Calculations : Calculate the specific optical rotation using the following expression, namely :

$$\text{For Liquids, } [\alpha]_D^{20} = \frac{\alpha}{ld}$$

$$\text{For solids, } [\alpha]_D^{20} = \frac{100\alpha}{lc}$$

where, l = the length in dm of the polarimeter tube,

d = the relative density of the substance, and

c = the concentration of the substance expressed as a percentage w/v.

19.4.2.2. Cognate Assays

The specific optical rotation of a large number of potent pharmaceutical substances may be determined by the above mentioned procedure but specific concentrations and method of preparation of solutions is according to the *official compendium* as stated in Table 19.2 below :

Table 19.2 : Specific Optical Rotation of Some Important Official *Compounds

S.No.	Substance	Concentration/Preparation of Solution	Specific Optical Rotation $[\alpha]_D^{20}$
1.	Acetylcysteine	Dissolve 1.25 g in a mixture of 1 ml of a 0.1% w/v soln. of disodium edetate, 7.5 ml of 1 M NaOH and sufficient mixed phosphate buffer (pH 7.0) to produce 25 ml.	+ 21° to + 27°
2.	Alanine	Dissolve 2.5 g in sufficient 7 M HCl to produce 25 ml.	+ 13.5° to + 15.5°
3.	Amoxycillin Sodium	A 0.25% w/v soln. in a 0.4 w/v soln. of potassium hydrogen phthalate	+ 240° to + 290°
4.	Ampicillin	0.25 w/v solution.	+280° to + 305°
5.	Ampicillin Sodium	0.25% soln. in a 0.4% soln. of potassium hydrogen phthalate.	+258° to + 287°
6.	Apomorphine Hydrochloride	1% w/v soln. in 0.02 M HCl.	- 48° to - 52°
7.	Ascorbic Acid	10% w/v solution.	+ 20.5° to + 21.5°
8.	Beclomethasone Dipropionate	1% w/v solution in 1, 4-dioxan	+ 88° to + 94°
9.	Benethamine Penicillin	1% w/v in chloroform	+ 120° to + 125°
10.	Benzylpenicillin Potassium	2% w/v in CO ₂ -free water	+ 270° to + 300°
11.	Betamethasone	0.5% w/v in 1, 4-dioxan	+ 114° to + 122°
12.	Calcium Pantothenate	5.0% w/v in CO ₂ free water	+ 25.5° to + 27.5°
13.	Carbidopa	Dissolve 0.25 g in sufficient AlCl ₃ soln. (BP, 1993) to produce 25 ml with the aid of ultra sound.	- 22.5° to - 26.5°

14.	Cephalexin	0.5% w/v in phthalate buffer (pH 4.4)	+ 149° to + 158°
15.	Chloramphenicol	6% w/v in absolute ethanol	+ 18.5° to + 20.5°
16.	Cindamycin Hydrochloride	4% w/v solution	+ 135° to + 150°
17.	Cocaine	Dissolve 0.6 g in 2.5 ml of 1 M HCl and add sufficient DW to produce 25 ml	- 79° to - 81°
18.	Colchicine	50 mg in ethanol (96%) to produce 10 ml	- 235° to - 250°
19.	Cytarabine	0.25 g in DW to produce 25 ml	+ 154° to + 160°
20.	Deslanoside	2% w/v soln. in anhydrous pyridine	+ 6.5° to + 8.5°
21.	Dexamethasone	1% w/v soln. in 1, 4-dioxan	+ 75° to + 80°
22.	Dicloxacillin Sodium	1% w/v soln.	+ 128° to + 143°
23.	Digitoxin	2.5% w/v soln. in chloroform	+ 16.0° to + 18.5°
24.	Emetine Hydrochloride	1.25 g of the dried substance in sufficient DW to produce 25 ml	+ 16° to + 19°
25.	Ephedrine	Dissolve 2.25 g in 15 ml of 2 M HCl and dilute to 50 ml with DW	- 41° to - 43°
26.	Ergocalciferol	Dissolve 0.2 g rapidly without heating, in aldehyde-free ethanol (96%) to produce 25 ml	+ 103° to + 107°
27.	Erythromycin	2% w/v soln. in absolute ethanol	- 71° to - 78°
28.	Ethinylloestradiol	5% w/v in pyridine	- 27° to - 30°
29.	Framycetin Sulphate	10% w/v soln.	+ 52.5° to + 55.5°
30.	Gentamycin Sulphate	10% w/v soln.	+ 107° to + 121°
31.	Griseofulvin	1% w/v soln. in dimethylformamide	+ 354° to + 464°
32.	Hydrocortisone Acetate	1% w/v soln. in 1, 4-dioxan	+ 158° to + 167°
33.	Hyoscyamine Sulphate	5% w/v soln.	- 24° to - 29°
34.	Naproxen	2% w/v soln. in chloroform	+ 63° to + 68°
35.	Sucrose	20% w/v soln.	+ 66.8°
36.	Testosterone	1% w/v soln. in absolute ethanol	+ 83° to + 90°

THEORETICAL AND PRACTICAL EXERCISES

- What is the fundamental theory of 'polarimetry' ? How would you depict the plane polarized light, right circularly polarized light and left circularly polarized light diagrammatically ?
- (a) Describe the optical system of a polarimeter with labelled diagram.
(b) Explain the following explicitly :
 - Non-superimposability and optical activity,
 - Superimposability and loss of optical activity, and
 - Specific optical rotation.
- How would you determine the optical rotation of the following pharmaceutical substances ?
 - Ibuprofen,
 - Levodopa,
 - Atropine sulphate, and
 - Spearmint oil.

4. How would you carry out the determination of specific optical rotation of the following official compounds ?
- | | |
|-------------------------|----------------------------|
| (i) Adrenaline, | (ii) Betamethasone, |
| (iii) Chloramphenicol, | (iv) Dicloxacillin sodium, |
| (v) Ergocalciferol, and | (vi) Griseofulvin. |

RECOMMENDED READINGS

1. Weissberger, A., Ed., '**Techniques of Organic Chemistry**', Vol. III, I, **Separation and Purification**', 2nd ed., New York, Interscience, 1956.
2. Glasstone, S., '**Textbook of Physical Chemistry**', New York, D. Van Nostrand, 1960.
3. Highuchi, T. and E. Brochmann-Hausen, Eds '**Pharmaceutical Analysis**', New York, interscience, 1961.
4. Mislow, K., '**Introduction to Stereochemistry**', New York, W.A. Benjamin, 1966.
5. Conors, K.A., '**A Textbook of Pharmaceutical Analysis**', 2nd. ed., New York, John Wiley & Sons, 1975.
6. Sunshine, I., Ed., '**Methodology for Analytical Toxicology**', Cleveland, CRC-Press, 1975.

20

NEPHELOMETRY AND TURBIDIMETRY

CONTAINS :

- 20.1 Introduction
- 20.2 Theory
- 20.3 Instruments for Nephelometry and Turbidimetry
 - 20.3.1 Instruments For Nephelometry
 - 20.3.2 Instruments For Turbidimetry
- 20.4 Assay of pharmaceutical substances
 - 20.4.1 Turbidimetric assay
 - 20.4.2 Nephelometric assay

20.1. INTRODUCTION

When light is passed through moderately stable suspensions, a portion of the incident radiant energy is dissipated by virtue of the absorption, refraction, and reflection, whereas the remaining portion gets transmitted. It is quite evident that the optical characteristics of each suspension shall alter according to the concentration of the dispersed phase. In fact, the measurement of the intensity of the transmitted light through such suspensions *vis-a-vis* the concentration of the dispersed phase serves as the basis of *turbidimetric analysis*.

In another situation when the aforesaid suspension is viewed at 90° (*i.e.*, right angles) to the direction of the incident light (Figure 20.1) the system appears opalescent on account of the reflection of light from the particle of the suspension. This scattering of light is termed as the **Tyndall effect**. The observed opalescence or cloudiness is the net result caused by irregularly and diffusely reflected light from the suspension. Consequently, the ultimate measurement of the intensity of the scattered light as a true representation of the actual concentration of the dispersed phase forms the basis of nephelometric analysis (derived from Greek : **nephele**-means cloud). It is found to be most sensitive and effective specially in the case of very dilute suspensions having a concentration not greater than 100 mg L^{-1} . However, it is interesting to observe that the technique of turbidimetric analysis resembles that of flame photometry ; and nephelometric analysis to that of fluorimetry.

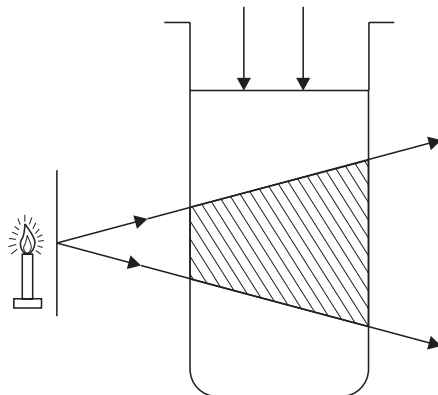

Figure 20.1 : Tyndall Effect.

20.2. THEORY

In short, **turbidimetry** is the measurement of the degree of attenuation of a radiant beam incident on particles suspended in a medium, the measurement being made in the directly transmitted beam. Thus, turbidity (T) may be expressed as :

$$T = \frac{1}{l} \cdot \ln \cdot \frac{I_o}{I_t} \quad \dots(a)$$

where, T = Turbidity,

l = Length of dispersion through which the light passes,

I_o = Intensity of incident light,

I_t = Intensity of transmitted light, and

n = Refractive index of the dispersion medium.

The **International Pharmacopoeia** describes **Turbidance (S)** as—‘a measure of the light-scattering effect of suspended particles’ ; and **Turbidity (r)** as—‘a measure of the decrease in incident beam intensity per unit length of a given suspension’.

Nephelometry exclusively refers to the *measurement of the light scattered by suspended particles at right angles (perpendicular) to the incident beam.*

Turbidimetry or nephelometry may be employed judiciously for the measurement of precipitates produced by the interaction of very dilute solutions of reagents, or other particular matter, for instance : concentration of colloidal dispersion of organic and inorganic compounds and suspensions of bacterial cells (microbial assays).

It is, however, pertinent to mention here that in order to achieve the prime objective of obtaining fairly reproducible analytical results and absolutely consistent results the following experimental parameters may be observed strictly with regard to the production of suspensions of reasonably uniform characteristic features, namely :

- (i) the extremely dilute suspensions of bacterial cells may be employed to encounter the problems caused due to birefringence,
- (ii) the concentrations of the two ions that combine to yield the respective precipitate, besides the ratio of the concentrations in the solutions that are mixed,
- (iii) the procedural details including the order and the rate of mixing,
- (iv) the amounts of other salts and substances present *e.g.*, the protective colloids such as : dextrin, gelatin, gum arabic ; and
- (v) the temperature.

20.3. INSTRUMENTS FOR NEPHELOMETRY AND TURBIDIMETRY

Nephelometric and turbidimetric measurements may be made with a fairly reasonable accuracy and precision by using either standard instruments available commercially or by improvising other similar devices. A brief description of such available means shall be discussed below :

20.3.1. INSTRUMENTS FOR NEPHELOMETRY

In general, nephelometric measurements essentially require an instrument with a photocell placed in position so that it may receive selectively the scattered light rather than the transmitted light. As this principle and geometry also hold good specifically to fluorimeters; and, therefore, these can be employed as nephelometers by selecting proper filters.

The following instruments are used invariably for nephelometric measurements, namely :

20.3.1.1. Duboscq Colorimeter

In actual practice, the so called 'visual' nephelometer (comparator type) have been more or less superseded by the photoelectric instruments. Nevertheless, a **Duboscq Colorimeter** with a slight modification may be used conveniently for nephelometric analysis, for instance :

- (a) the path-of-light should be arranged in such a fashion that the light enters the side of the cups at right angles to the plungers rather than through the bottoms,
- (b) clear-glass-tube with opaque bottoms are to be used instead of the normal cups,
- (c) the glass-plungers are precisely fitted with opaque sleeves, and
- (d) the light that enters at right angles to the clear-glass-tubes should be monitored carefully so as to achieve an equal-illumination on either sides.

Now, a standard suspension is placed in one clear-glass-tube, and the unknown solution is treated exactly in an identical fashion and placed in the other clear-glass-tube. Finally, the dividing line existing between the two fields in the eye-piece (Figure 20.2) must be distinctly thin and sharp, and it must disappear when the two fields are matched properly.

The Duboscq Colorimeter should always be maintained meticulously neat and clean. The clear-glass-tubes and the plungers are either rinsed with distilled water or with the solution to be measured.

First of all, it is necessary to ensure that the readings are zero when the plungers just touch the bottoms of the clear-glass-tubes. Now, the standard solution is placed in one clear-glass-tube, whereas an equal volume of the solution in question (unknown) in the other ; bearing in mind the fact that the clear-glass-tubes should never be filled above their respective shoulders.

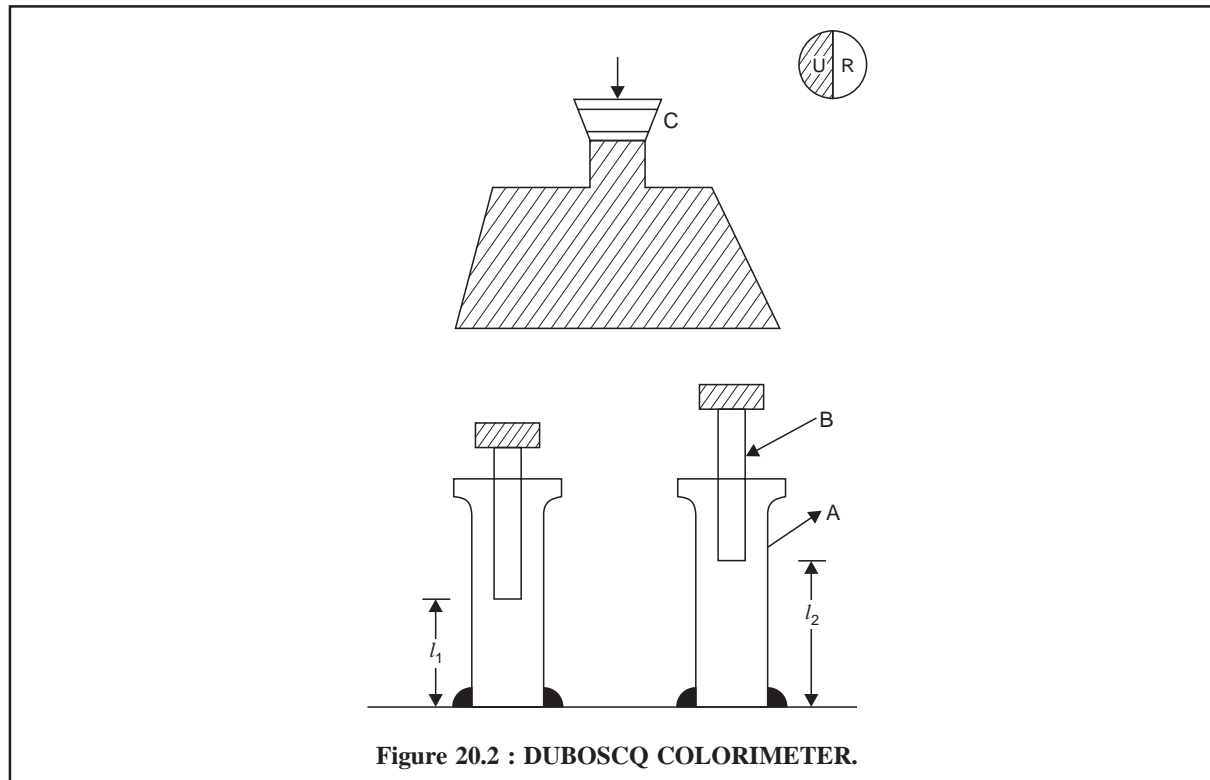

Figure 20.2 : DUBOSCQ COLORIMETER.

The various components of a Duboscq Colorimeter are as follows :

- A = Clear glass tube with opaque bottom,
- B = Glass plungers fitted with opaque sleeves, and
- C = Eye piece.

Subsequently, set the unknown solution at a scale reading of 10.0 mm and simultaneously adjust the standard until the fields are matched equally. Perform at least five similar adjustments with the clear-glass-tube (A) containing the standard solution, and calculate the mean value. Care should always be taken that the plungers (B) always remain below the surface of the liquid. However, it is advised to visualize the match-point from above and below :

Assuming **Beer's Law** holds good the concentration of the solution in question (unknown) may be determined by the help of the following expression :

$$c_1 l_1 = c_2 l_2$$

(known) (unknown)

or

$$c_2 = \frac{c_1 l_1}{l_2} \quad \dots(b)$$

where, l_1 = Average readings for the clear-glass-tube having the solutions of known concentration,

l_2 = Average reading for the clear-glass-tube having the solution of the unknown concentration,

c_1 = Concentration of the known solution, and

c_2 = Concentration of the unknown solution.

It may, however, be observed that if $l_2 = 10.0$, the standard scale when multiplied by 10 shall give the percentage concentration of the sample in terms of the standard.

20.3.1.2. Nephelometer

The most important characteristic feature of a **nephelometer** is the '*reflector*' that has been specifically designed so as to collect the light which has undergone scattering by the particles present in a turbid or cloudy solution. A typical nephelometer is illustrated in Figure : 20.3, below :

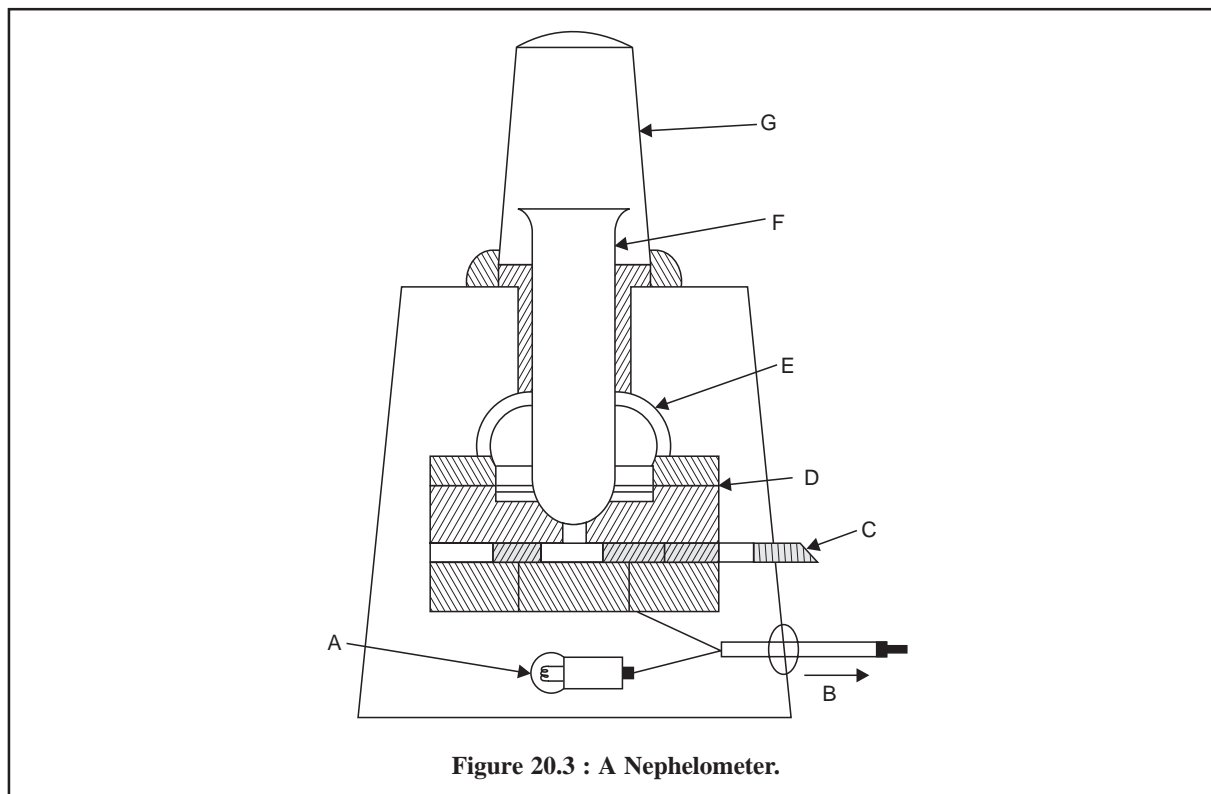

Following are the different parts of a nephelometer :

- A = A light source,
- B = A sensitive micro-ammeter,
- C = Filter wheel with a series of colour filters,
- D = An annular photocell,
- E = A reflector to collect the scattered light,
- F = A test tube, and
- G = A metal test tube cover to exclude extraneous light.

The test solution (sample) is placed in a test tube (F) that has been duly rested on a light source (A) as exhibited in Figure 20.3. The scattered light caused by the particles in a turbid or cloudy solution is immediately directed by the reflector (E) on to an annular photocell (D). A series of standard colour filters are usually provided in the form of a filter-wheel (C) so as to facilitate analysis of coloured solutions ; taking care that the filter chosen must be similar to colour to that of the solution. The current generated after passing through the photocell (*i.e.*, light energy is being converted to electrical energy) is recorded by a sensitive micro-ammeter (B). The test tube is provided with a metallic cover (G) to get rid of any extraneous light. Usually a nephelometer is provided with zero-setting controls, sensitivity adjusting device and a set of previously matched test tubes.

20.3.2. INSTRUMENTS FOR TURBIDIMETRY

In fact, either visual or photoelectric colorimeters may be satisfactorily employed as turbidimeters. However, the use of the blue filter normally enhances the sensitivity appreciably. It has been observed that the light transmitted by a turbid solution does not normally obey the *Beer-Lambert Law* accurately and precisely. Therefore, as an usual practice it is advisable to construct a '**calibration curve**' by employing several standard solutions. The concentration of the unknown solution may be read off directly from the above calibration curve as is done in the case of colorimetric assays.

20.4. ASSAY OF PHARMACEUTICAL SUBSTANCES

A number of pharmaceutical substances are assayed either turbidimetrically or nephelometrically. The assay methods of these *two* techniques shall be discussed briefly below with the help of appropriate examples :

20.4.1. TURBIDIMETRIC ASSAY

A large number of antibiotics, namely : chlortetracycline, doxycycline, gentamicin, neomycin, streptomycin, tobramycin and the like may be assayed turbidimetrically with fairly good accuracy.

20.4.1.1. Assay of Chlortetracycline

Theory : Inoculate a medium consisting of : peptone : 6 g, beef extract : 1.5 g, yeast extract : 3 g, sodium chloride : 3.5 g, D-glucose monohydrate : 1.0 g, dipotassium hydrogen orthophosphate : 3.68 g, potassium hydrogen orthophosphate : 1.32 g and dissolve in sufficient water to produce 1 L with a known quantity of a suspension of *Staphylococcus aureus* (NCTC 6571*) so as to obtain a readily measured opacity after an incubation of about 4 hours. The micro-organisms must exhibit a sensitivity to the antibiotic under investigation to such an extent that a sufficiently large inhibition of growth takes place in the prevailing conditions of the test.

In actual practice, it is always advisable that the inoculated medium should be used immediately after its preparation. Using a phosphate buffer of pH 4.5 (dissolve 13.61 g of KH_2PO_4 in about 750 ml of water, adjusting the pH to 4.5 with 0.1 M NaOH and diluting to 1 L with water), prepare solutions of the Standard Preparation and the substance under investigation at concentrations presumed to be equal.

* NCTC = National Collection of Type Culture

To enable the validity of the assay to be examined, it is desirable to use at least three doses of the Standard Preparation and of the substance being examined. It is also advisable to use doses in logarithmic progression in a parallel line assay.

Materials Required : Standard chlortetracycline ; sterilized media (as described above) : 1 L ; authentic and pure strain of microorganism *Staphylococcus aureus* (NCTC 6571) ; formaldehyde solution (34-37% w/v) 10 ml ; matched identical test tubes : 20 ;

Procedure : Distribute into identical test-tubes an equal volume of standard tetracycline solution and the sample to be examined (having presumed equal concentrations) and add to each tube an equal volume of inoculated nutrient medium (for instance 1 ml of the solution and 9 ml of the medium). Prepare at the same time two control tubes without the chlortetracycline, one containing the inoculated medium and the other identical with it but treated immediately with 0.5 ml of formaldehyde solution. These tubes are used to set the optical apparatus employed to measure the growth.

Place all the tubes, randomly distributed, in a water-bath or other suitable means of bringing all the tubes rapidly to 35-37 °C *i.e.*, the incubation temperature and maintain them at that temperature for 3 to 4 hours, taking due precautions to ensure uniformity of temperatures and identical incubation times. After incubation, stop the growth of the microorganisms by adding 0.5 ml of formaldehyde solution, each tube and subsequently measure the opacity to at least three significant figures using a suitable optical apparatus. From the results calculate the potency of the substance being examined *i.e.*, chlortetracycline by standard statistical methods.

Note : (a) **Rectilinearity* of the dose-response relationship, transformed or untransformed, is often obtained only over a very limited range. It is this range that must be used in calculating the activity and it must include at least three consecutive doses in order to permit rectilinearity to be verified,**

(b) **Use in each assay the number of replications per dose sufficient to ensure the required precision. The assay may be repeated and the results combined statistically to obtain the required precision and to ascertain whether the potency of the antibiotic being examined is not less than the minimum required.**

20.4.1.2 Cognate Assays

A few other official antibiotics in BP (1993) may also be assayed by adopting the method stated above, but using specific micro-organism, definite final pH of the medium, pH of the phosphate buffer, potency of solution (U per ml) and the incubation temperature. A few typical examples are given in Table 20.1 below :

Table 20.1 Assay of Antibiotics Turbidimetrically

S. No.	Antibiotic	Micro-organism	Medium Final pH	Phosphate Buffer pH	Potency of Solution U per ml	Incubation Temperature (°C)
1.	Doxycycline	Staphylococcus aureus (NCTC 7447)**	7.0	4.5	0.003 to 0.010	35 to 37
2.	Gentamycin	-do-	7.0	8.0	0.6 to 1.25	35 to 37
3.	Neomycin	Klebsiella pneumoniae (NCIMB 9111)***	7.6	8.0	1.5 to 4	35 to 37
4.	Streptomycin	-do-	7.0	8.0	2.4 to 3.8	35 to 37
5.	Tobramycin	Staphylococcus aureus (NCTC 7447)	7.0	7.0	0.75 to 1.875	35 to 37

* In order to obtain the required rectilinearity it may be necessary to select from a large number three consecutive doses, using corresponding doses of the standard preparation and of the substance being examined. (BP, 1993, Appendix XIV A, p, 167 and 168).

**NCTC : National Collection of Type Cultures

***NCIMB : National Collection Industrial and Marine Bacteria

20.4.2. NEPHELOMETRIC ASSAY

Nephelometric assay may be employed for the determination of sulphate (SO_4^{2-}) and phosphate (PO_4^{3-}) ions quite efficiently. These two estimations shall be discussed below in an elaborated manner :

20.4.2.1. Assay of Sulphate Ion (SO_4^{2-})

Theory : From actual experience it has been observed that it is always difficult to reproduce the turbidity of a dilute barium-sulphate-suspension. Hence, it is very important to adopt the underlying experimental procedure very closely and rigidly so as to obtain reasonably good results, namely :

- (i) The rate of formation (velocity) of the precipitation along with the concentration of the reactants should be monitored and controlled by the addition of pure solid barium chloride having a definite grain size,
- (ii) The rate at which barium chloride undergoes dissolution controls the velocity of the reaction,
- (iii) Both NaCl and HCl (reagent) are added before the commencement of the precipitation so as to check the growth of microcrystals of BaSO_4 ,
- (iv) An optimum pH must be maintained that essentially decreases the effect of variable quantities of the other electrolytes, possibly present in the sample, upon the size of the suspended BaSO_4 particles,
- (v) Most importantly the presence of glycerol-ethanol solution helps to stabilize the turbidity,
- (vi) Each reaction-vessel must be shaken gently both at the same rate and the same number of times so as to obtain a uniform particle size (BaSO_4),
- (vii) The unknown sample should be treated exactly in an identical manner (as the standard solution), and
- (viii) The time-gap between the time of precipitation and the time of measurement (of turbidity) should always be kept constant.

Materials Required

- (i) **Standard Sulphate Solution :** 1.814 g of K_2SO_4 (dry) is dissolved in DW and diluted to 1 L in a graduated flask :

96.08 g of SO_4^{2-} present in 174.26 g of K_2SO_4 , therefore,

$$1.000 \text{ g of } \text{SO}_4^{2-} \text{ ion is present in } \frac{174.26}{96.08} = 1.8136 \text{ g of } \text{K}_2\text{SO}_4 \text{ in 1 L}$$

$$= 1.814 \text{ g of } \text{K}_2\text{SO}_4 \text{ in 1 L}$$

or 1.000 mg of SO_4^{2-} ion present in 1 ml

i.e., the solution contains 1.000 mg of SO_4^{2-} per ml

- (ii) **Sodium Chloride-Hydrochloric Acid Reagent :** 60 g of NaCl is dissolved in 200-ml of DW, add to it 5 ml of concentrated HCl (AR) and dilute to 250-ml with DW,
- (iii) **Barium Chloride :** The BaCl_2 crystals that pass through the 20 mesh sieve and retained by the 39 mesh sieve are only used,
- (iv) **Glycerol-Ethanol-Solution :** Prepared by dissolving pure glycerol in absolute ethanol (1 : 2).

Procedure

1. Transfer 0.5, 1.0, 1.5, 2.0, 2.5, 3.0, 3.5 and 4.0 ml of the standard potassium sulphate solution from a burette into each separate 100-ml volumetric flask and number them from 1 to 8,
2. To each flask (1 to 8) pipette out 10 ml of the NaCl-HCl reagent and 20 ml of the glycerol-ethanol solution, and dilute to 100 ml mark with DW,
3. Weigh and add 0.3 g of sieved BaCl_2 to each flask (1 to 8) stopper them, and shake for exactly one minute by inverting flask once in one second (All BaCl_2 must dissolve),

4. Permit each flask to stand for 2-3 minutes and read out the turbidity in the nephelometer,

Caution : Avoid any tiny air-bubbles sticking to the inner walls of the matched test-tubes.

5. By employing the most-concentrated, K_2SO_4 solution, as standard, and by the help of the sensitivity control, adjust the micro-ammeter reading to 100-divisions,
6. A 'Blank' solution is prepared by adopting the above operations sequentially, but without the addition of the K_2SO_4 solution,
7. Insert the Blank solution in the nephelometer and adjust to zero reading of the scale by the aid of zero-control-knob,
8. Check the reading of the most-turbid-solution, and adjust any deviation from 100 by means of the sensitivity control,
9. Repeat the measurements with the remaining standard sulphate solution and plot the nephelometer reading V_S the SO_4^{2-} ion content per ml,
10. 'Unknown Solution'—Determine the SO_4^{2-} ion content of an unknown solution, for instance : 0.4 mg per ml, by means of the standard-calibration-curve.

20.4.2.2. Assay of Phosphate Ion (PO_4^{3-})

Theory : The underlying principle for the assay of PO_4^{3-} ion by nephelometry is the formation of strychnine-molybdophosphate complex (I).

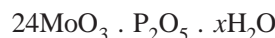
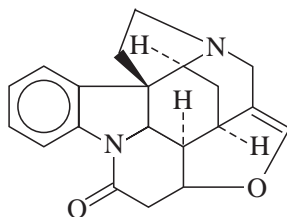

(I)

The turbidity thus obtained is white in appearance and consists of very fine particles of the above complex. Extra care must be taken for **not** agitating the precipitate so as to avoid agglomeration of the same quickly. Likewise, temperature variation should also be avoided as far as possible because the precipitate is somewhat sensitive.

Materials Required

1. **Standard Phosphate Solution :** 1.721 g of KH_2PO_4 , previously dried at $110^\circ C$, is dissolved in 1 L of DW in a 1000-ml volumetric flask and make up the volume with DW upto the mark.

The resulting diluted solution contains $0.01 \text{ mg } P_2O_5 \text{ ml}^{-1}$.

2. Molybdate-Strychnine Reagent

Solution 'A' : (Acid Molybdate Solution) : Weigh 30 g of molybdenum trioxide (Mo_2O_3) in a 500-ml conical flask, add to it 10 g of Na_2CO_3 and 200 ml of DW. Boil the contents of the flask until a clear solution is achieved. Filter the hot solution, add 200 ml of 5 M. H_2SO_4 , allow to cool and dilute to 500 ml with DW.

Solution 'B' (Strychnine-Sulphate Solution) : Weigh 1.6 g strychnine sulphate in 100 ml of DW. Warm it gently, cool and dilute to 500 ml with DW.

Molybdate-strychnine reagent is prepared by dissolving solution-B shaking the resulting mixture vigorously. The bluish-white precipitate thus obtained is filtered through What man No : 42 filter paper and the resulting clear solution may be used within 20 hours.

Note : (i) Strychnine must be handled with gloves on as it is a very toxic alkaloidal substance and under no condition it should be ingested,

(ii) Molybdate-strychnine reagent is always prepared afresh by mixing solution-B to solution-A, because the addition of the acid-molybdate solution to the strychnine-sulphate solution gives a precipitate after 24 hours, and

(iii) Solutions A and B can be stored indefinitely.

3. **Saturated Sodium Sulphate Solution :** A saturated aqueous solution of sodium sulphate is prepared at 50 °C, cooled to room temperature and filtered before use.

4. **Sulphuric Acid (1 M) :** 27.0 ml of concentrated H_2SO_4 is diluted to 500 ml in a graduated flask.

Procedure

1. Transfer accurately 1.0, 2.0, 4.0, 6.0, 8.0, and 10.0 ml of the standard phosphate solution with a burette into each 100 ml volumetric flasks.
2. 18 ml of 1 M H_2SO_4 is added to each flask, followed by 16 ml of saturated sodium sulphate solution, and diluted to 95 ml with DW.
3. Add 2.0 ml of the molybdate-strychnine reagent to the resulting solution and make up the volume to 100 ml.
4. The contents of the flask is mixed by gently inverting it a number of times, but without shaking vigorously.
5. Keep the flasks aside for at least 20 minutes so as to allow the turbidities to develop before making the measurements.
6. A 'blank' solution is prepared by performing the above operations sequentially, but without the addition of the phosphate solution.
7. By employing the most concentrated solution as the initial standard, adjust the microammeter reading to 100 divisions.
8. Place the 'blank' solution into the matched test-tube of the nephelometer and adjust the reading to zero.
9. Check the reading of the most turbid solution, and adjust any deviation from 100 by the help of the sensitivity control.
10. Repeat the measurements with the remaining standard phosphate solution and plot the nephelometer reading V_s the mg P_2O_5 per ml.
11. **Unknown Solution :** Determine the phosphate content of an unknown solution, for example : containing 0.005 mg P_2O_5 per ml by the help of the standard-calibration graph.

THEORETICAL AND PRACTICAL EXERCISES

1. What is Tyndall Effect ? How does it affect 'nephelometry' and 'turbidimetry' ? Explain.
2. (a) Define 'turbidance' and 'turbidity' as per the International Pharmacopoeia.
(b) Discuss the 'theoretical aspect' and 'experimental parameters' for turbidimetry.
3. Describe the under mentioned analytical instruments with the help of a neat diagram and working modalities :
(a) Duboscq colorimeter,
(b) Nephelometer, and
(c) Photoelectric colorimeter.

4. How would you accomplish the '**turbidimetric assay**' of the following medicinal compounds :
- (i) Chlortetracycline, (ii) Doxycycline,
(ii) Gentamycin, and (iv) Tobramycin.
5. Describe in details the assay of the following '**drug substances**' by using a '**nephelometer**' :
- (i) SO_4^{2-} ion, (ii) PO_4^{3-} ion.

RECOMMENDED READINGS

1. Fritz, J.S. and G.H. Schenk, '**Quantitative Analytical Chemistry**', 3rd. ed., Boston, Allyn and Bacon. 1974.
2. Alberty, R. A., '**Physical Chemistry**', 7th ed., New York, Wiley, 1987.
3. Svehla, G, Ed., '**Comprehensive Analytical Chemistry**', Vol. XIX (1986) ; Vol. XX (1985) ; Vol. XXII (1986), Amsterdam, Elsevier Publishers, 1986.
4. Jeffrey, G.H. J. Bassett., J. Mendham and R.C. Denney, '**Vogel's Textbook of Quantitative Chemical Analysis***,' 5th ed., New York, Longman Scientific and Technical, 1989.
5. Schirmer, R.E., '**Modern Methods of Pharmaceutical Analysis**, 2nd. Vol. 1, Boston, CRC Press 1991.