

21

ULTRAVIOLET AND ABSORPTION METHODS

CONTAINS :

- 21.1 Introduction
- 21.2 Theory
 - 21.2.1 Electromagnetic spectrum
 - 21.2.2 Schematic representation of electromagnetic spectrum
 - 21.2.3 Molar absorptivity
 - 21.2.4 Laws of photometry
 - 21.2.5 Spectral presentation
 - 21.2.6 Structural features
 - 21.2.7 Absorption of radiant energy by molecules
 - 21.2.8 Factors influencing absorption of radiant energy
- 21.3 Instrumentation
 - 21.3.1 Single beam spectrophotometer
 - 21.3.2 Double beam spectrophotometer
- 21.4 Assay methods
 - 21.4.1 Methodology
 - 21.4.2 Spectrophotometers
 - 21.4.3 Preparation of sample
 - 21.4.4 Measurement of extinction (E)
 - 21.4.5 Examples
 - 21.4.6 UV-absorption characteristics of some official pharmaceutical substances

21.1. INTRODUCTION

In the earlier sections of this part, the various analytical methods based upon the measurements of mass and volume have been described at sufficient length with their typical applications in the analysis of pharmaceutical substances. Comparatively older methods of analysis, such as **colorimetry** is entirely based upon the interaction of specifically visible light with a sample. In this particular instance, just the visible portion of the electromagnetic radiation spectrum within the range of 400 and 700 nanometers (nm) to which a human eye is sensitive, has been employed. In a situation whereby the sample is made to interact with a wide spectrum of wavelengths in a given zone of electromagnetic radiation, consequently giving rise to a collection of measurement signals as a function of wavelength is termed as a **spectrum**, ultimately putting forward the most common terminology **spectrochemical analysis** or **spectroscopy**.

21.2. THEORY

21.2.1. ELECTROMAGNETIC SPECTRUM

It has been established beyond any reasonable doubt that the absorption and the emission of energy in the **electromagnetic spectrum** take place in distinct separate pockets or photons. The relationship

existing between the energy of a photon and the frequency matching its propagation may be expressed as follows :

$$E = h\nu \quad \dots(a)$$

where, E = Energy (in ergs),

ν = Frequency (in cycles sec^{-1}), and

h = Universal constant termed as Planck's constant (6.6256×10^{-27} erg sec).

However, the relationship between wavelength and frequency may be expressed as follows :

$$\nu = c/\lambda \quad \dots(b)$$

where, λ = Wavelength (in cms),

c = Velocity of propagation of radiant energy in vacuum (which is nothing but the speed of light in vacuum ; and is equivalent to 2.9979×10^{10} cm sec^{-1}).

The radiant power of a beam is designated by its intensity of radiation, which in turn is directly proportional to the number of photons per second that are propagated in the beam.

Monochromatic Beam : A beam that carries radiation of only one distinctly separate wave length is known as **monochromatic**.

Polychromatic or Heterochromatic : A beam that carries radiation of several wavelengths is termed as **polychromatic or heterochromatic**.

21.2.2. SCHEMATIC REPRESENTATION OF ELECTROMAGNETIC SPECTRUM

Figure 21.1, provides a schematic representation of electromagnetic spectrum, whereby the beam of a white light from an incandescent solid (*e.g.*, the filament of an electric bulb consisting of numerous separate waves of different wavelengths) is passed through a prism thereby giving rise to a continuous spectrum wherein each colour corresponds to waves of a particular individual wavelength.

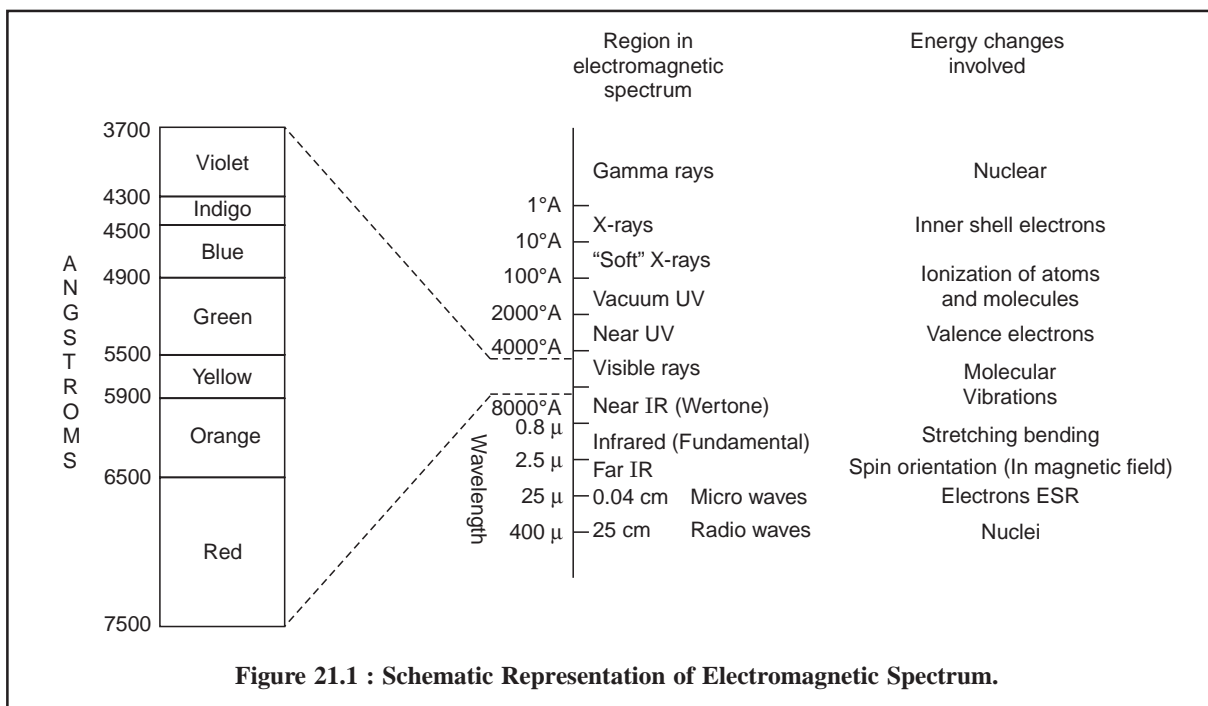

A few salient points from Figure 21.1 are enumerated below :

- (a) The visible spectrum constitutes a small portion of the complete electromagnetic radiation spectrum that extends from the ultra-short wave gamma rays at one end to that of the radio-waves at the other (400-700 nm),
- (b) The wave length scale is nonlinear,
- (c) **γ -Rays Region** : *Mossbauer Spectroscopy* (due to absorption) and *γ -Ray Spectroscopy* (due to emission) are used as analytical means.
- (d) **Inner-shell Electrons** : *X-Ray absorption spectroscopy* (due to absorption) and *X-Ray Fluorescence spectroscopy* (XRF) (due to emission) are employed as analytical means.
- (e) **From Vacuum-UV to Infra-Red Region** : *UV-VIS, IR-spectroscopy, spectrophotometry, atomic absorption spectroscopy* (AAS) (due to absorption) and *atomic emission spectroscopy* (AES, ESS, ICP) ; *atomic fluorescence spectroscopy* (AFS) (due to emission) are used as analytical techniques.
- (f) **Microwave Region** : *Microwave spectroscopy* and *electron spin resonance* (ESR) (due to absorption) are employed as analytical methods.
- (g) **Radiowave Region** : *Nuclear Magnetic Resonance* (NMR) (due to absorption) is used as analytical method.

21.2.3. MOLAR ABSORPTIVITY

Usually, a molecule exists in the state of *lowest energy* the **ground state**. However, absorption of light of the right frequency (in the UV-region) raises a molecule to an **excited state** *i.e.*, a state of *higher energy*. Considering the example for ethylene *two* situations arise, namely :

- (a) **Ground State** : Here, both π electrons are in the π orbital. This configuration is designated as π^2 , where the superscript represents the number of electrons in that orbital.
- (b) **Excited State** : Here, an electron is in the π orbital while the other in the π^* orbital (having an opposite spin). Thus, the resulting configuration $\pi\pi^*$ is obviously less stable due to the fact that :
 - (i) only one electron helps to hold the atom together, and
 - (ii) the other electron tends to force them apart.

The **molar absorptivity** is mostly controlled by *two* vital factors, namely :

(i) polarity of the excited state, and (ii) probability of the electronic transition. So as to materialize an interaction, a photon should evidently strike a molecule very closely within the space of the molecular dimensions. The probability of the electronic transition, designated as 'g', shall be responsible for the target hits that may ultimately lead to absorption. However, the molar absorptivity may be expressed as follows :

$$\frac{-\partial P}{P} = \frac{1}{3} g C N_A A(\partial b/1000) \quad \dots(c)$$

where, N_A = Avogadro Number,

A = Cross-sectional target area*

$\frac{1}{3}$ = Statistical factor (to permit random orientation),

g = Probability of the electronic transition

By inserting numerical constants and integration Eq. (c) we have :

$$\log (P_0/P) bC = \epsilon = (0.87 \times 10^{20}) g A \quad \dots(d)$$

where, ϵ = Molar absorptivity

Absorption with $\epsilon > 10^4$ is considered high-intensity absorption.

* May be obtained from X-Ray Diffraction Data.

21.2.4. LAWS OF PHOTOMETRY

The 'Laws of Protometry' has been discussed in Chapter-1 of this text under section 4.1.

21.2.5. SPECTRAL PRESENTATION

Absorption spectra may be presented in a number of fashions as depicted in Figure 21.2, namely :

- (a) Wavelength Vs Absorbance,
- (b) Wavelength Vs Molar Absorptivity, and
- (c) Wavelength Vs Transmittance.

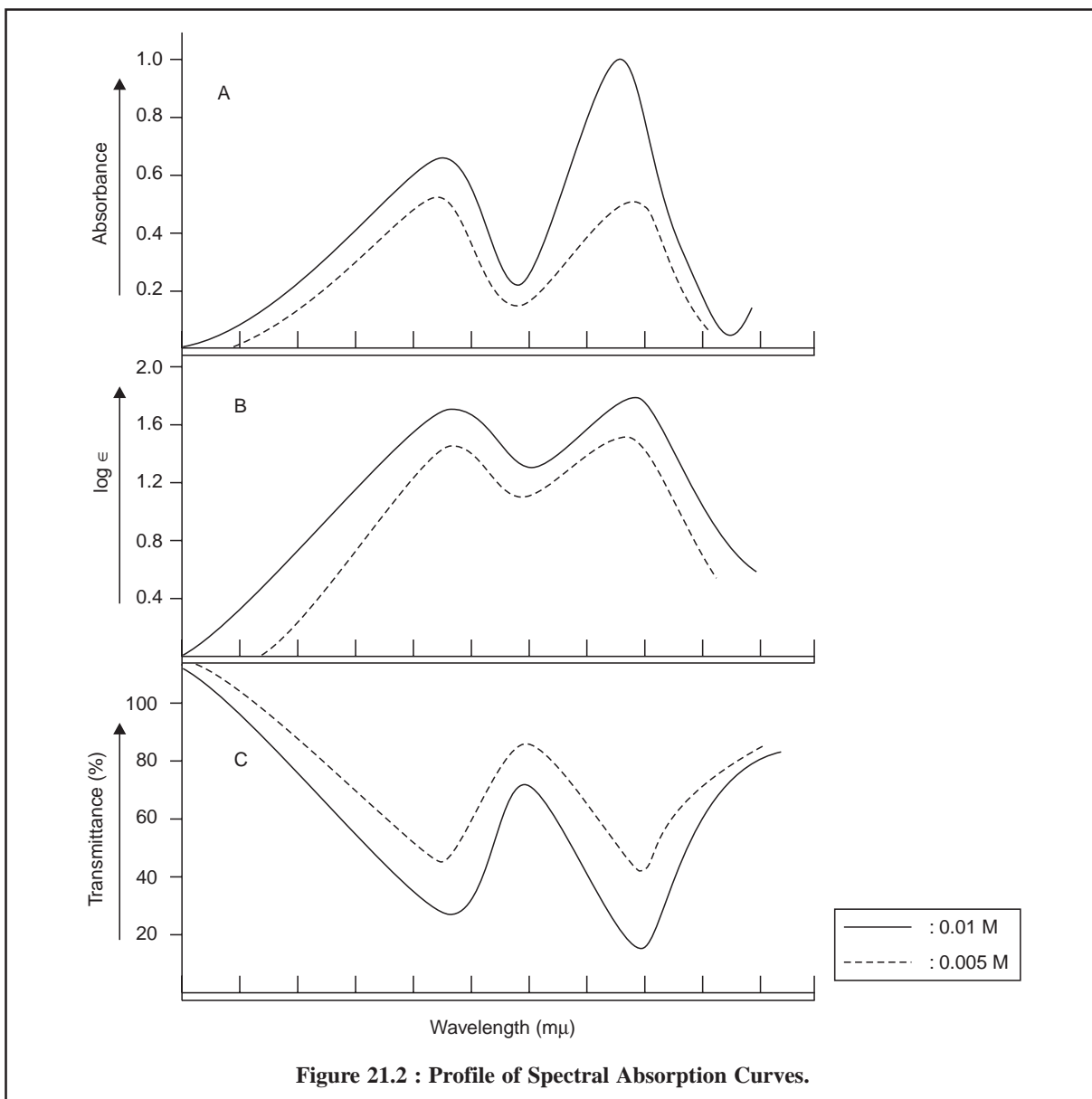

Figure 21.2 : Profile of Spectral Absorption Curves.

A few important features related to spectral presentation are enumerated below :

- (a) In order to simplify the conversion of spectra in qualitative identification the spectral data should be plotted either as $\log A$ or as $\log \epsilon$ Vs wavelength, thereby giving rise to the following expression :

$$\log A = \log \epsilon + \log b + \log c \quad \dots(e)$$

where, b = Cell-length, and

c = Sample concentration.

From Eq. (e), one may observe that the resulting curve is independent of both cell-length and sample concentration,

- (b) The identity and nonconformity of sample may be ascertained by simply carrying out the comparison of spectral presentation both up or down the ordinate scale,
- (c) In order to obtain both reproducible and fairly consistent accurate plot the ordinate in absorbance values must be plotted on graph paper having 1 mm equivalent to 0.005 absorbance,
- (d) Most importantly all relevant informations pertaining to : solvent employed, concentrations used, the band pass and ultimately the Model/Make of the Spectrophotometer,
- (e) **Choice of Solvents** : For instance :
 Water-common solvent for a number of inorganic substances,
 Ethanol (96% w/v)-good choice as fairly polar solvent,
 Cyclohexane-common solvent for a number of aromatic compounds.

21.2.6. STRUCTURAL FEATURES

While discussing the structural features special emphasis shall be laid only to those molecules that are capable of absorption within the wavelength region from 185 to 800 m μ .

A few *salient structural features* are enumerated below :

- (i) Compounds having single bonds involving σ -valency electrons usually display absorption spectra below 150 m μ . Such spectra will be observed only in interaction with other types.
- (ii) Excitation help in promoting a p -orbital electron into an antibonding σ orbit thereby giving rise to an $n \rightarrow \sigma^*$ transition, for example : ethers, sulphides, amines, and alkyl halides.
- (iii) Unshared p -electrons exist besides σ -electrons in saturated compounds having covalent bonds and heteroatoms, for instance : N, S, O, Cl, Br, I,
- (iv) Unsaturated compounds give rise to the absorption spectra by the displacement of π -electrons.
- (v) Molecules that have single chromophores (*i.e.*, absorbing groups)-normally undergo transitions almost very close to their respective wavelengths,
- (vi) Interestingly, a molecule containing only a single chromophore of a particular species shall absorb light of approximately the same wavelength as that of a molecule having two or more insulated chromophores, however, the intensity of the absorption shall be directly proportional to the number of the latter type of chromophore present in the compound.

Examples : (a) *meta*-orientation about an aromatic ring, and

(b) interposition of a single methylene (= CH₂) moiety.

The above two instances are sufficient to insulate chromophores from each other totally,

- (vii) **Hyperconjugation**—is usually observed when slight interaction takes place with alkyl radicals attached to chromophores.
- (viii) In fact, *four* different types of absorption bands have so far gained cognizance in the spectra of organic compounds, which are namely : *K-bands* ; *R-bands* ; *B-bands* ; and *E-bands*.

These bands will be discussed briefly here with regard to the structural features.

(a) **K-bands** : They normally arise from π - π structures and result from $\pi \rightarrow \pi^*$ transitions.

These are invariably characterized by high molar absorptivity.

Examples :

(i) A diene : $C = C - C = C$ to $C^+ = C = C - C^-$; where K-band is due to the resonance transition,

(ii) Vinyl benzene or acetophenone : *i.e.*, aromatic compounds having chromophoric substitution.

(b) **R-bands** : They usually arise from $n \rightarrow \pi^*$ transitions. They seldom display very noticeable results in aliphatic compounds, but marked and pronounced bathochromic shifts (*i.e.*, shifting of absorption towards longer wavelengths—as in extended open-chain-conjugated systems) do take place when—SH, —OH and —NH₂ replace hydrogen atom in unsaturated groups. Thus, R-bands help in the confirmation of a particular structure whereby additional bands are obtained by appropriate modifications in the electronic-structure of the parent compound.

(c) **B-bands** : These are rather weak-type of absorption bands. They are characteristic of both heteroatomic and aromatic molecules and may also consist of fine vibrational sub-bands.

(d) **E-bands** : They usually result from oscillations of electrons in aromatic-ring systems,

(ix) **Conjugated Systems :**

It is quite evident that the conjugated systems might fail to display the expected conjugated bands due to the following *two* reasons, namely :

(a) Orbitals of adjacent multiple bonds are at right angles instead of being parallel, and

(b) Resonating dipolar structures cannot be envisaged.

The resulting spectrum may seem to appear as a mere superimposition of the spectra of the individual chromophoric groups.

Examples : Allene and ketene systems

Polyphenyls (*e.g.*, *m*-terphenyl)

(x) **Steric Hindrance** : The attachment of bulky functional entities to ring systems offering steric hindrance may ultimately prevent the coplanarity of two resonating structures either completely or partially.

However, partial hindrance specifically leads to such characteristic bands pertaining to those parts of conjugated system.

21.2.7. ABSORPTION OF RADIANT ENERGY BY MOLECULES

In reality, the molecules are as energetic as the modern teenagers. They invariably rock, roll, twist, jerk, and bend, and if the music is of the right rhythm, choice, and frequency, the electrons within the molecule shall move from the 'ground state' to the 'excited state'.

Explicitly, the total energy in a molecule is the sum of the energies associated with the translational, rotational, vibrational and electronic motions of the molecule/or electrons/or nuclei in the molecule. These *four* motion-related-energies are briefly explained below :

(a) **Transational Energy** : It is associated with the motion (velocity) of the molecule as a whole.

(b) **Rotational Energy** : It is associated with the overall rotation of the molecule.

(c) **Vibrational Energy** : It is associated with the motion of atoms within the molecule.

(d) **Electronic Energy** : It is associated with the motion of electrons arounds the nuclei.

Electrons generally found in the conjugated double bonds invariably give rise to spectra in the UV and visible regions of the electromagnetic spectrum.

It is pertinent to mention here that an excited electron normally returns to the ground state in about 10^{-9} to 10^{-8} seconds. Consequently, energy must now be released to compensate for the energy absorbed by the system. In actual practice however, the following *three* situations arise, namely :

Firstly, if the electron returns directly to the ground state, the net effect would be evolution of heat.

Secondly, if the electron returns to the ground state by passing through a second excited state, the net outcome would be release of energy in the form of heat and light.

Thirdly, if a large amount of energy is absorbed by certain substances, bonds may be ruptured and thereby giving rise to altogether new compounds.

For instance : ergosterol on being subjected to UV radiation yields cholecalciferols which are, in fact, altogether new substances.

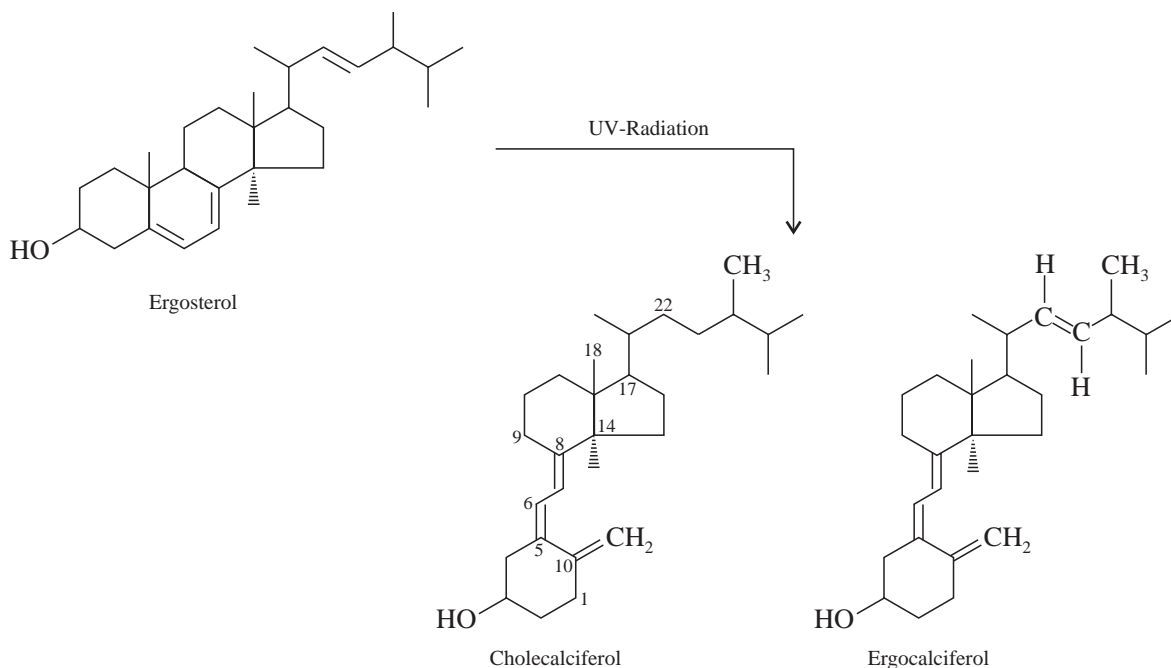

In general, the changes incurred are usually minimal and for this very reason the UV-spectrophotometry is considered to be a non-destructive method of analysis.

However, the relative energies due to electrons (*d*), vibration (*c*), and rotation (*b*) are more or less in the order of 10,000 : 100 : 1 ; and the total energy for any one state at any material time may be depicted by the following expression :

$$E_{\text{Total}} = E_{\text{Electronic}} + E_{\text{Vibrational}} + E_{\text{Rotational}}$$

The diagrammatic representation of the potential energy of a diatomic molecule showing :

(i) Potential energy-nuclear separation curves, and

(ii) Relationship between electronic transitions and absorption curves ; is illustrated in Figure 21.3.

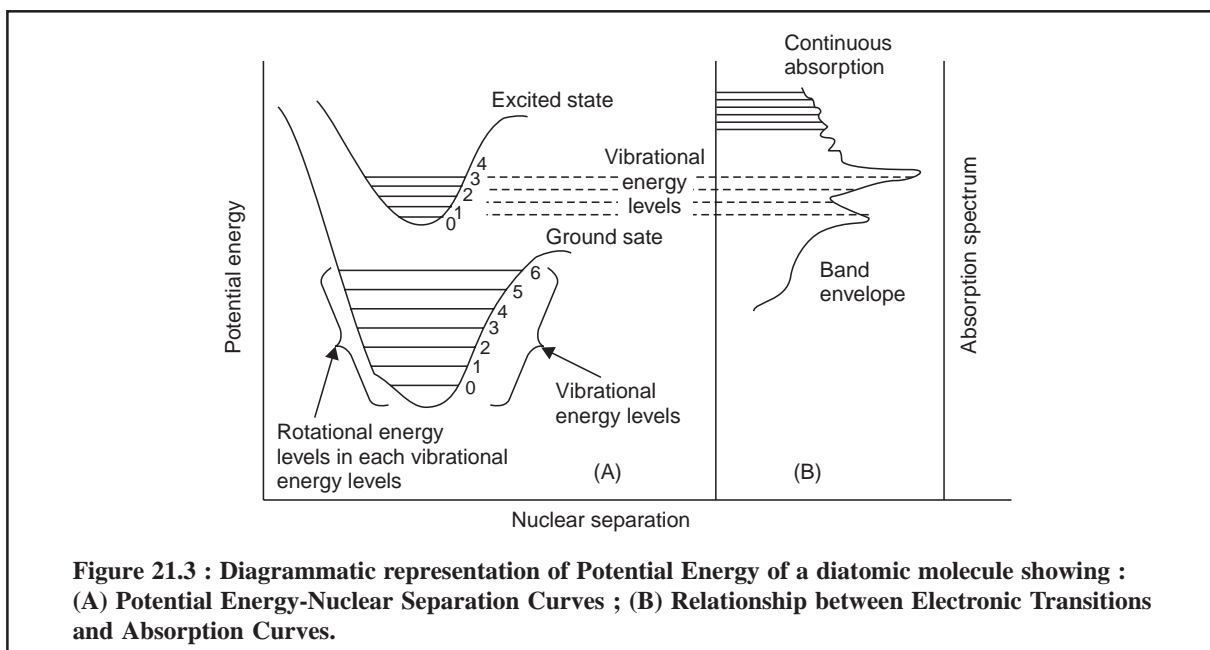

Figure 21.3 : Diagrammatic representation of Potential Energy of a diatomic molecule showing : (A) Potential Energy-Nuclear Separation Curves ; (B) Relationship between Electronic Transitions and Absorption Curves.

Explanation of various features in Figures 22.3 :

- (i) The mutual forces are also zero when the nuclei are at infinity ; but as the latter come closer to one another, forces of attraction start operating and the potential energy decreases,
- (ii) The potential energy records an increase when the nuclei get very close to one another thereby causing repulsion,
- (iii) The atoms, therefore, can vibrate about the minimum position RC at the vibrational level 0,
- (iv) The electronic configuration of the molecule gives rise to different quantum of energy associated with it which may be indicated and represented by the horizontal lines in Figure 21.3 (0 → 6),
- (v) At ambient temperature, the molecule is in the lowest ebb of the vibrational level of the ground state,
- (vi) The corresponding electronic transition from the ground state to an excited state, is represented by the upper curve in Figure 21.3,
- (vii) Rotational energy variations usually accompany electronic variations, however, they are comparatively smaller in size and often yield a fine structure superimposed on the electronic-vibrational change,
- (viii) The frequency of the absorption bands associated with the transition is put forward by the following expression :

$$h\nu = E_{\text{Excited state}} - E_{\text{Ground state}} \quad \dots(e)$$

where, h = Planck's Constant,

ν = Frequency, and

E = Energy level.

In reality, their appearance as a pattern comes into being chiefly from transitions to the various vibrational levels of the excited state as shown in Figure 21.3.

21.2.8. FACTORS INFLUENCING ABSORPTION OF RADIANT ENERGY

There are various cardinal factors that govern measurement of absorption of radiant energy, namely :

- (a) Absorbing groups (or Chromophores),
- (b) Solvent effects,
- (c) Effect of temperature, and
- (d) Inorganic ions.

These vital factors would be discussed briefly with specific examples hereunder :

21.2.8.1. Absorbing Groups (or Chromophores)

A 'chromophore' is a group which when attached to a saturated hydrocarbon produces a molecule that absorbs a maximum of visible or UV energy at some specific wavelength.

A few typical examples having electronic absorption bands for various representative chromophores are provided in the following Table : 21 : 1 :

Table 21.1 : Absorption Bands for Representative Chromophores with Examples :

S.No.	Chromophore	System	λ_{\max}	ϵ_{\max}	λ_{\max}	Examples
1.	Acetylide	$-C \equiv C-$	175-180	6000	—	Acetylene
2.	Azo	$-N = N-$	285-400	3-25	—	Azomethane
3.	Aldehyde	$-CHO$	210	strong	280-300	Acetaldehyde
4.	Carboxyl	$-COOH$	200-210	50-70	—	Acetic acid
5.	Nitrile	$-C \equiv N$	160	—	—	Acetonitrile
6.	Nitro	$-NO_2$	210	strong	—	Nitromethane
7.	Thioketone	$C = S$	205	strong	—	Thiobenzophenone
8.	Esters	$-COOR$	205	50	—	Ethyl acetate
9.	Ether	$-O-$	185	1000	—	Diethyl ether
10.	Amine	$-NH_2$	195	2800	—	Methyl amine
11.	Thiol	$-SH$	195	1400	—	Thiophenol
12.	Iodide	$-I$	260	400	—	Methyl iodide
13.	Bromide	$-Br$	208	300	—	Ethyl bromide
14.	Sulphone	$-SO_2-$	180	—	—	Dapsone
15.	Nitroso	$-N = O$	302	100	—	<i>p</i> -Nitroso phenol

21.2.8.2. Solvent Effects

The absorption spectrum of a pharmaceutical substance depends partially upon the solvent that has been employed to solubilize the substance. A drug may absorb a maximum of radiant energy at a particular wavelength in one solvent but shall absorb practically little at the same wavelength in another solvent. These apparent changes in spectrum are exclusively due to various characteristic features, namely :

- (a) Nature of the solvent,
- (b) Nature of the absorption band, and
- (c) Nature of the solute.

Some salient features of 'Solvent Effects' are enumerated below :

- (i) Absorption bands of many substances are relatively sharper and may also exhibit fine structure when measured in solvents of low dipole moment,

- (ii) Interactions of solvent-solute are found to be much stronger in such substances where strong dipole forces are involved,
- (iii) Solvent effects do help in reorganizing electronic transitions of the type $n-\pi^*$ that essentially involve the nonbonding electrons of nitrogen and oxygen,
- (iv) The nonbonding electrons of nitrogen and oxygen usually interact with polar solvents that ultimately give rise to a characteristic shift to shorter wavelengths.

Example : The spectrum of Iodine in a nonpolar solvent like CHCl_3 is found to be distinctly different (purple to the naked eye) when the same is compared in a polar solvent such as $\text{C}_2\text{H}_5\text{OH}$ (brownish to the naked eye) in Figure 21.4.

- (v) A spectrum normally shows appreciable changes with varying pH when an ionizable moiety is present in the molecule and thereby constitutes part of the chromophore structure.

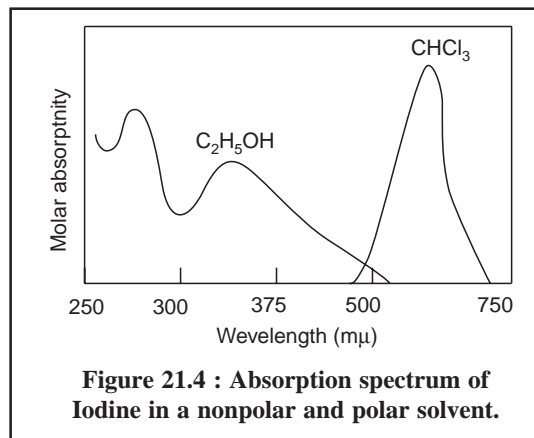

Figure 21.4 : Absorption spectrum of Iodine in a nonpolar and polar solvent.

21.2.8.3 Effect of Temperature

- Low temperature offer sharper absorption bands of many pharmaceutical substances than at room temperature,
- Vibrational resolutions are definitely well-defined at low temperatures because of the following two reasons, namely :
 - (a) Fewer vibrational levels are occupied, and
 - (d) Degree of solute-solvent interaction is minimised,
- Samples in highly rigid or viscous media (*e.g.*, glass) is examined frequently in phosphorescence methods and also in some fluorescence methods.

21.2.8.4 Inorganic Ions

The 'chromophoric entities' present in the inorganic compounds are of two types, namely :

- (a) **Involving several atoms :** such as : permanganate (MnO_4^-) and dichromate (Cr_2O_7^-) moieties, and
- (b) **Involving single atoms :** Those having incomplete outer d -electron shells where closely spaced, unoccupied energy levels are available in abundance for instance : coordination compounds with Rare Earths : *e.g.*, Be, Sr, Ra, and Transition Elements : Cr, Mn, Ni, Pt, Ag, Pd, Cd, Hg, Au,

It is worth while to note that the absorption spectra for these elements are caused due to a charge-transfer-process whereby an electron gets transferred form one part of the ion to another.

Interestingly, inclusion of readily polarizable atoms do exert an effect likewise to lengthening a conjugated chain. Examples :

Inorganic Ions	Colour	Molar Absorptivity
FeCl_3	Yellow	Lower
FeBr_3	Orange	Higher

21.3. INSTRUMENTATION

A spectrophotometer is an instrument which is capable of isolating ‘monochromatic’ radiation ; or that which specifically contains a dispersing element : a prism or a grating.

It is pertinent to mention here that there are a plethora of commercially available spectrophotometers of varying design *i.e.*, single-beam (simple), double-beam (more precise and accurate) and microcomputer controlled built-in-recorder with separate printer ; and obviously having a wide-price-range from Rs 3.0 Lacs to Rs 17.5 Lacs. Evidently, it is practically impossible to describe either all or even a major fraction of, the various spectrophotometers available.

Therefore, in this particular section the following *two* types of spectrophotometers shall be discussed briefly :

- (a) Single-beam Spectrophotometer, and
- (b) Double-beam Spectrophotometer.

21.3.1. SINGLE BEAM SPECTROPHOTOMETER

The desired wavelength is isolated by using a prism or grating and auxiliary mirrors and slits that collectively form a monochromator of the instrument. The wavelength dial on a spectrophotometer is adjusted to a specific value, but the radiation leaving the exit-slit is found to be rarely monochromatic. The schematic diagram of the Beckman Model DU-Spectrophotometer is illustrated in Figure 21.5.

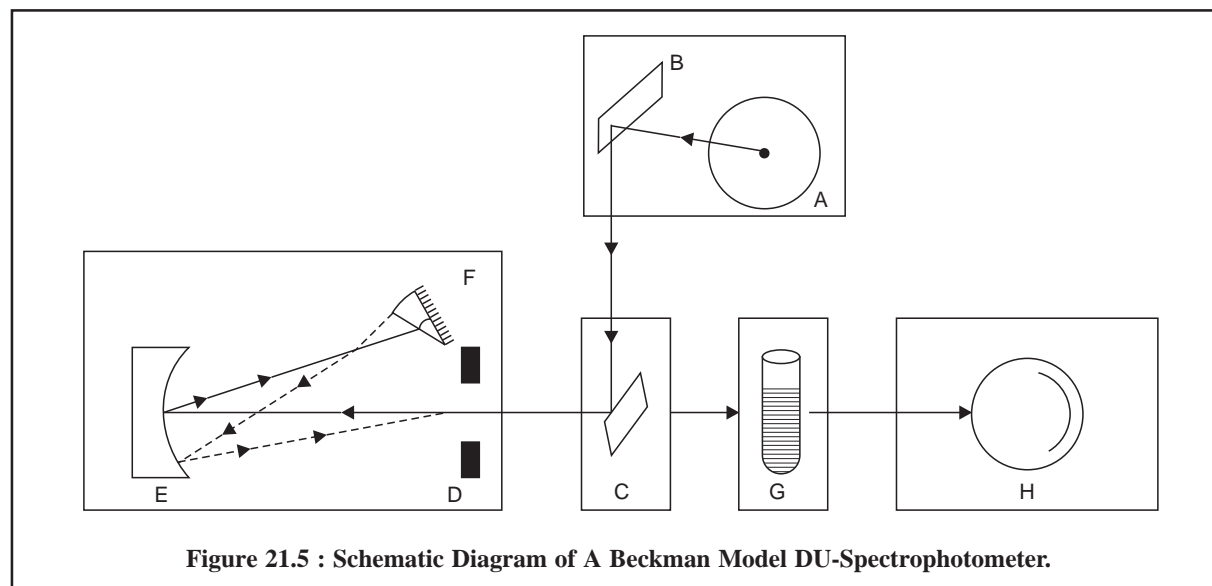

The various components of Figure 21.5 are given below :

- | | |
|----------------------------|---------------------------------|
| A = Source of light ; | E = Collimator mirror ; |
| B = Condensing mirror ; | F = Prism (Reflecting) ; |
| C = Slit-entrance mirror ; | G = Cuvette containing sample ; |
| D = Adjustable slit ; | H = Phototube ; |

Light from the source (A) is focussed on the condensing mirror (B) and directed in a beam to the 45° slit-entrance mirror (C). The slit-entrance mirror subsequently deflects the beam through the adjustable slit (D) and into the monochromator to the collimator mirror (E). As a result the light falling on the collimator mirror is rendered parallel and reflected to the prism (F), where it undergoes refraction. The back surface of the prism is aluminized, so that the light refracted at the first surface is reflected back through the prism, undergoing further refraction as it emerges. The desired wavelength of light is selected by rotating the wavelength selector fixed on top of the monochromator case. This control, in fact, adjusts the position of the

prism. The spectrum from the prism is directed back to the collimating mirror which centres the chosen wavelength of light on the slit and the sample (G). Light passing through the sample strikes the phototube (H), causing a voltage to appear across a load-resistor. The voltage is duly amplified and registered on either the strip-chart recorder or the null-meter.

The **Milton Roy Spectronic[®]-20** definitely provides a low-cost and easy to operate instrument, that is still capable of achieving absorbance readings accurate to ± 1 or 2%.

Beckman Instruments, one of the pioneers in Analytical Instruments and dominating this field since 50 years, has come up with their latest **Beckman DU Series 60 Spectrophotometer**, which essentially makes use of *two* different sources of light, namely :

- (a) H₂ or D₂ Lamp-for measurement in UV-region, and
- (b) Tungsten Lamp-for measurement in visible region,

thereby permitting measurements from 190-1000 nm. A computer system has also been provided to enable automatic spectrochemical measurements and perform calculations simultaneously.

21.3.2. DOUBLE BEAM SPECTROPHOTOMETER

The quantum leap amalgamated with qualified success in the advancement of Analytical Instruments necessitated for more rapid and precise and accurate measurements in UV and visible spectroscopy. It could be accomplished by the help of the following *two* cardinal modifications, namely :

- (a) Need for a continuous change in wavelength so that light through the blank and through the sample may be monitored continuously, and
- (b) Measurements done with a recording spectrophotometer.

The above two modifications have been duly incorporated in a double-beam spectrophotometer. Figure 21.6, depicts the schematic diagram of the optical system involved in a Lambda-2 microcomputer-controlled UV-VIS Spectrophotometer (Perkin-Elmer).

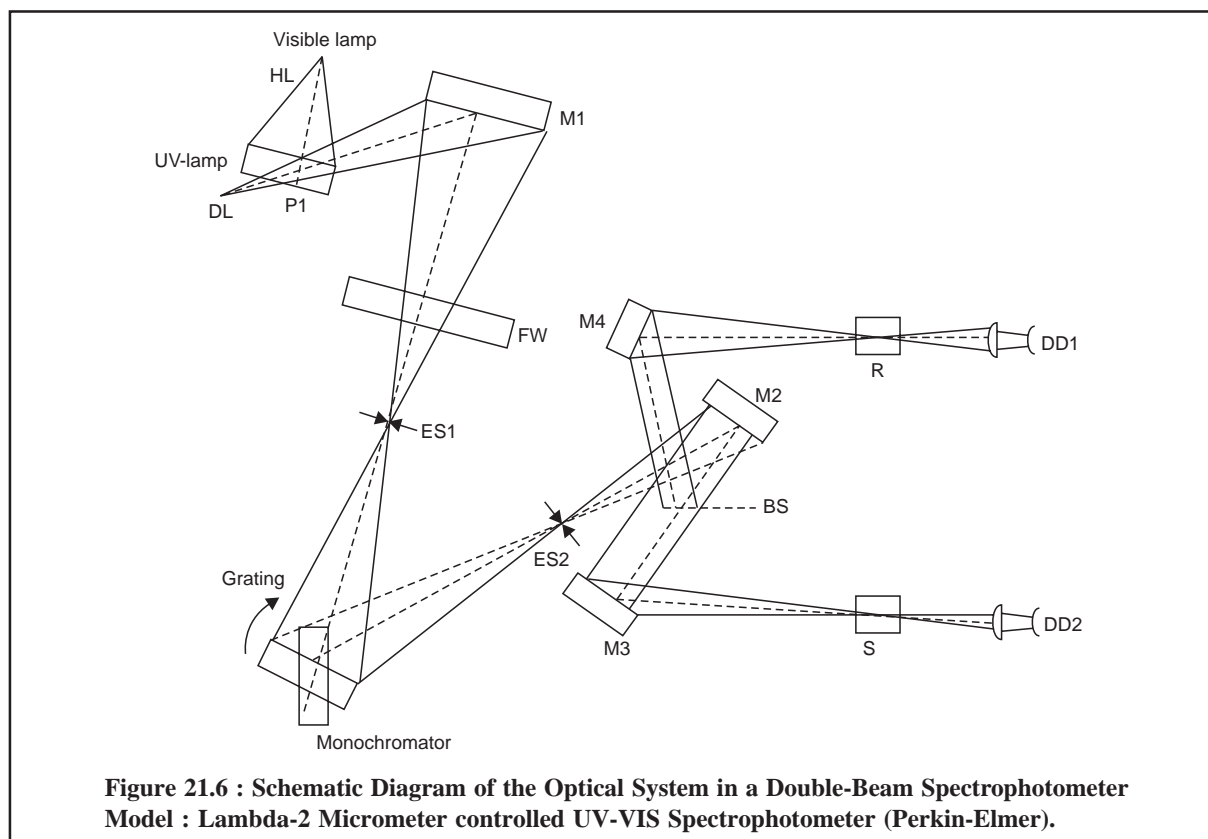

The various components of Figure 21.6 are stated below :

VIS-LAMP = Tungstem Lamp.

UV-LAMP = Hydrogen Lamp (HL),

= Deuterium Lamp (DL),

P_1 = Movable source-selection mirror,

M_1, M_2, M_3, M_4 = Mirrors,

FW = Filter wheel,

ES 1 = Entrance slit,

ES 2 = Exit slit,

BS = Beam Splitter,

R = Reference Sample Holder,

S = Sample holder (Test), and

DD 1, DD 2 = Diode detectors.

In fact, the source beam is usually split in two different manners, namely :

- (a) **Separated in Space** : In this instance, the source beam is split between the sample cell-path and the reference cell-path, and finally detected by two diode detectors. Here, the two detectors should be adequately matched so that no changes occur relative to each other during the measurements,
- (b) **Separated in Time** : In this case, the source beam is split with the help of an optical chopper which permits the source beam to alternate between the sample cell-path and the reference cell-path. Here, the source should be stable enough so that no changes take place in the radiant energy during the chopping time.

Keeping in view, this specific, rigid and stringent requirement, the separation-in-space method is found to be normally of lower precision and accuracy than the separation-in time-method.

Evidently, the optical choppers are quite expensive, and therefore, the instrument manufacturers very often utilize the separation-in-space method for the routine measurement spectrophotometers.

However, the most sophisticated double-beam spectrophotometer is usually pretty expensive by virtue of the following facts, namely :

- (i) Greater operating stability,
- (ii) Rapid speed compared to single-beam instruments,
- (iii) Complicated optical system involved, and
- (iv) Recording device for recording absorbance Vs wavelength.

The source beam after passing through the movable source selection mirror (M_1), gets reflected and subsequently makes an entry through the filter wheel (FW) and the entrance-slit (ES 1) to the monochromator. The grating is adjusted duly to allow the beam to pass through the exit slit (ES 2) and fall upon the mirror (M_2). At this juncture the beam splitter (B S) splits the reflected beam from mirror (M_2) into two halves : one gets reflected through the mirror (M_4), and passes through the reference sample holder (R) to the diode-detector (DD 1) ; whereas the second one is reflected through the mirror (M_3), passes through the sample holder (S) to the diode detector (DD 2). In fact, Figure 21.6, represents the double-beam operation of a beam separated-in-space.

Double beam spectrophotometers are being manufactured by various well-known manufacturers across the world, such as : SUMADZU ; VARIAN ; CECIL ; BECKMAN ; PERKIN ELMER ; etc., to name a few. These instruments are mostly based on microcomputer-controlled devices with built-in recorder to accomplish faster speed and greater operating stability.

21.4. ASSAY METHODS

21.4.1. METHODOLOGY

In general, when a radiation is made to pass through a layer of a solution containing an absorbing pharmaceutical substance, a portion of the radiation is absorbed by it, whereas the intensity of the radiation emerging from the solution is always found to be less than the intensity of the radiation entering it. Therefore, the quantum of the absorption is designated in terms of the extinction E , that is represented by the following expression :

$$E = \log_{10} (I_0/I)$$

where, I_0 = Intensity of radiation passing into the absorbing layer, and

I = Intensity of radiation passing out of the absorbing layer.

Extinction is solely dependent upon the following *two* factors, namely :

- (a) Concentration of the absorbing substance present in the solution, and
- (b) Thickness of the absorbing layer taken for measurement.

Bearing in mind the ease in calculations and also the convenience of reference, the extinction of a 1-cm layer of a 1% w/v solution is usually recommended in most of the official compendia (*i.e.*, USP ; BP ; EP : IP :) for many pharmaceutical substances and is evaluated by the following expression :

$$E (1\% ; 1\text{-cm}) = E/cl$$

where, c = Concentration of the absorbing substance represented as a percentage (w/v) ; and

l = Thickness of the absorbing layer (cm).

It is however, pertinent to mention here that most pure pharmaceutical substances possess a characteristic value of $E (1\% ; 1\text{-cm})$ at a specific wavelength in a given spectroscopic-grade solvent (UVASOL^(R)-Merck). This particular property is the basis for most assay methods included in pharmacopoeia that are absolutely free from interfering materials, besides being utilized for identifying substances.

In all other instances, the recommended tests specified in pharmacopoeia and prescribed assay methods normally call for comparison against Reference Substances (RS) to ensure measurements under conditions identical for the substance under examination and the reference substance.

In actual practice, where a test or an assay recommends the usage of a Reference Substance, the spectrophotometric measurements are always performed first with the solution prepared from the Reference Substance by the directions provided in the specific monograph and then with the corresponding solution prepared from the substance under examination. Nevertheless, the second measurement must be done immediately after the first, by employing the same cell and the same instrumental parameters.

21.4.2. SPECTROPHOTOMETERS

Any appropriate spectrophotometer capable for measuring both in the ultra-violet (UV) and visible range of the spectrum must essentially consist of an optical system that should produce monochromatic light in the range 190-780 nm and a suitable device for measuring the extinction (E) precisely and accurately.

Besides, the two empty cuvettes (or cells) normally employed for the solution under examination and the reference substance (RS) should have exactly the same spectral features and characteristics. Importantly, when a double bond recording instrument is being employed the solvent cell is always placed in the reference beam.

21.4.3. PREPARATION OF SAMPLE

The pharmaceutical substance under examination is usually dissolved in a spectroscopic grade UVASOL^(R) SOLVENT. Particular care must be taken to employ solvents free from contaminants absorbing in the specific spectral region being used. In measuring the extinction of a solution at a given wavelength, the extinction of the solvent cell and its contents must not exceed 0.4 and should be preferably less than 0.2 when measured with reference to air at the same wavelength. Particularly, the solvent in the solvent cell should always be of the same purity, grade and batch as that employed to prepare the respective solution and above all it must be free from fluorescence at the wavelength of measurement.

Ethyl alcohol, methyl alcohol and cyclohexane (UVASOL^(R)-Grade) employed as solvents shall have an extinction, measured in a 1 cm cell at 240 nm with reference to water (spectroscopic grade), not exceeding 0.10.

21.4.4. MEASUREMENT OF EXTINCTION (E)

- (a) Unless otherwise prescribed, measure the extinction (E) or the absorbance (A), at the prescribed wavelength using a path-length of 1 cm at $25 \pm 1^\circ\text{C}$ (IP) and at $20 \pm 1^\circ\text{C}$ (BP). All the measurements are normally performed with reference to the solvent used to prepare the solution being examined, unless otherwise indicated in the individual monograph.
- (b) In the case of an assay or a limit test where the extinction forms the basis for a quantitative determination, a manually scanning instrument is employed invariably. In tests for identification, a recording instrument is always preferred ; besides, the concentration of the solution and the path-length are specifically monitored. In case, the laid down conditions are not suitable for a particular instrument, the thickness of the solution (*i.e.*, path-length) may be varied without altering the concentration of the solution,
- (c) Each assay of a pharmaceutical substance by UV-method specifies a wavelength at which maximum absorption takes place which implies the maximum occurring either precisely at or in the vicinity of the given wave length,
- (d) Pharmaceutical assays (*i.e.*, quantitative determinations) are normally performed at wavelength above 235 nm,
- (e) In case, the measurements are specifically to be carried out at a wavelength between the range 190-210 nm, the following extra and special precautions must be adhered to rigidly, namely :
 - (i) Purging the cell compartments with N₂,
 - (ii) Making use of only spectroscopic grade solvents *e.g.*, UVASOL^(R) (Merck), and
 - (iii) Making use of cells that are absolutely transparent in the region 190-210 nm.
- (f) The requirements for light absorption in the *official compendia* invariably apply to the dried, anhydrous, or solvent free material in all such monographs in which standards for loss on drying, water or solvent content are provided.

21.4.5. EXAMPLES

A few typical examples for the assay of pharmaceutical substances by UV-spectrophotometric method are described below :

A. Amoxicillin Trihydrate

Materials Required : Amoxicillin trihydrate : 0.17 g ; 100-ml volumetric flask ; 2 ; buffer solution pH 9.0 (Solution : I : Boric acid and Potassium Chloride (0.2 M)-Dissolve 12.366 g of Boric acid and 14.911 g of KCl in DW and dilute with water to 1000 ml ; Solution : II NaOH (0.2 N) : Dissolve 8.0 g of NaOH in CO₂-free DW to produce 1000 ml ; Now, transfer 50 ml of solution I into a 200-ml volumetric flask

and add to it 20.8 ml of solution II, then add sufficient DW to make up the volume to 200 ml) : 10 ml ; acetic anhydride-dioxan solution (add 1 ml of acetic anhydride to 50-ml of dioxan) : 1.0 ml ; imidazole-mercury reagent (dissolve 8.25 g of recrystallized imidazole in 60 ml of DW and add 10 ml of 5N HCl. Stir the solution magnetically and, add dropwise, 10 ml of a 0.27% w/v solution of Hg_2Cl_2 . Adjust the pH to 6.8 ± 0.05 with 5 N HCl (about 4.0 ml is needed) and add sufficient DW to produce 100 ml) : 10.0 ml ;

Procedure : Weigh accurately about 0.17 g of amoxicillin trihydrate and dissolve in sufficient DW to produce 500 ml. Now, transfer 10 ml of this solution into a 100 ml volumetric flask, add 10 ml of buffer solution pH 9.0 followed by 1 ml of acetic anhydride-dioxan solution, allow to stand for 5 minutes, and add sufficient water to produce 100 ml. Pipette 2 ml of the resulting solution into each of the two stoppered tubes. To tube 1 add 10 ml of imidazole-mercury reagent, mix, stopper the tube and immerse it in a water-bath previously maintained at 60°C for exactly 25 minutes, with occasional swirling. Remove the tube from the water-bath and cool rapidly to 20°C (Solution-1). To tube 2 add 10 ml of DW and mix thoroughly (Solution-2). Immediately, measure the extinctions of Solutions 1 and 2 at the maximum at about 325 nm, as detailed above, employing as the blank a mixture of 2 ml of DW and 10 ml of imidazole-mercury reagent for Solution-1 and simply DW for Solution-2.

Calculations : The content of $\text{C}_{16}\text{H}_{19}\text{N}_3\text{O}_5\text{S}$ may be calculated from the difference between the extinctions of Solution-1 and that of Solution-2 and from the difference obtained by repeating the operation using 0.17 g of amoxicillin trihydrate (RS), instead of the sample being examined and the declared content of $\text{C}_{16}\text{H}_{19}\text{N}_3\text{O}_5\text{S}$ in the amoxicillin trihydrate (RS).

Cognate Assays : Ampicillin can also be assayed by employing the above method using 0.15 g of the sample.

B. Folic Acid

Theory : Folic acid (I) undergoes cleavage by reduction with Zn-Hg in acidic medium to yield *p*-aminobenzoylglutamic acid (II). The primary aromatic amino group present in the latter is subsequently diazotized in the usual manner and coupled in acidic solution with N-(1-naphthyl)-ethylenediamine hydrochloride in the absence of light (caution). The colour thus produced has a maximum absorption at 550 nm and the extinction (E) is consequently compared with a calibration curve obtained from *p*-aminobenzoic acid (PABA) that has been duly diazotized and coupled exactly in the same fashion as the *p*-aminobenzoylglutamic acid.

The reaction involved is expressed by the following equation :

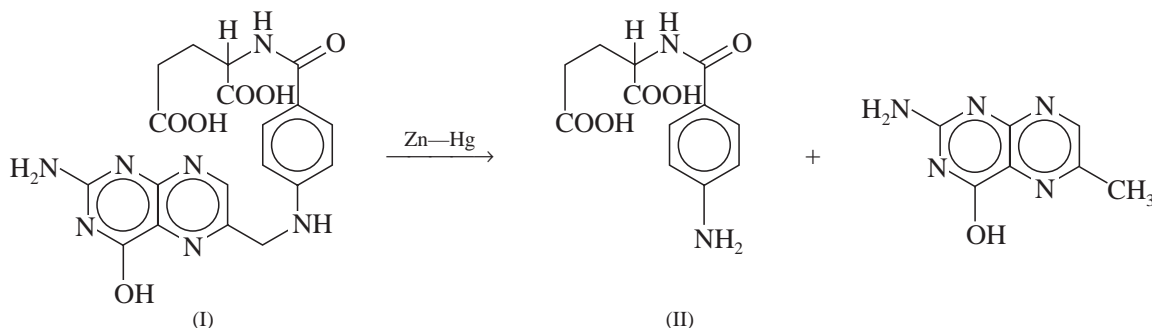

Note : In order to ensure that the extinctions recorded exclusively refer to folic acid (I), and also that they do not necessarily include a contribution from a free-primary-amino-aromatic-moiety obtained from a decomposition product, a blank estimation is always performed with the unreduced solution and an appropriate correction is applied. The colour thus corresponds to a definite quantity of $\text{C}_{16}\text{H}_{19}\text{O}_6\text{N}_7$. Thus, we have :

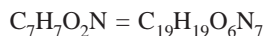

or 137 g of $C_7H_7O_2N = 447$ g of $C_{19}H_{19}O_6N_7$

or 1 g of $C_7H_7O_2N = 3.22$ g of $C_{19}H_{19}O_6N_7$

Materials Required : Folic acid : 0.05 g : 0.1 N NaOH : 100 ml ; 2 N HCl : 30 ml ; Zn-powder : 0.5 g ; sodium nitrite solution (0.1% w/v in DW) : 5 ml ; ammonium sulphamate (0.5% w/v in DW) : 5 ml ; N-(1-naphthyl) ethylene-diamine hydrochloride solution (0.1 % w/v in DW) : 5 ml ;

Procedure : Accurately weigh about 0.5 g, dissolve in 50 ml of 0.1 N NaOH and add sufficient 0.1 N NaOH to produce 100 ml (Solution-1). To 3 ml add 20 ml of 2 N HCl and dilute to 100 ml with DW. To 50 ml of this solution, add 0.5 g of zinc powder, allow to stand in a dark place for 20 minutes with intermittent shaking and filter, Dilute 10 ml of the filtrate to 25 ml with DW, add 5 ml of 2N HCl and 5 ml of a 0.1% solution of sodium nitrite, mix and allow to stand for 2 minutes. Add 5 ml of a 0.5% w/v solution of ammonium sulphamate, mix and allow to stand for 2 minutes. Now, add carefully 5 ml of a 0.1% solution of N-(1-naphthyl) ethylene diamine hydrochloride, mix thoroughly and allow to stand for 10 minutes. Add sufficient DW to produce 50 ml and measure the extinction of the resulting solution at about 550 nm, as discussed earlier, using as blank a solution prepared exactly in a similar manner but employing 25 ml of DW and beginning the procedure at “add 5 ml of 2 N HCl...”

To a further portion of 30 ml of solution-1, add 20 ml of 2N HCl and sufficient DW to produce 100 ml. Mix 10 ml of this solution with 15 ml of DW and repeat the operations stated above beginning the procedure at “add 5 ml of 2 N HCl ...”

Finally, subtract 1/10th of the extinction of the unreduced solution from that of the reduced solution and from the result thus obtained calculate the amount of $C_{19}H_{19}O_6N_7$, using the result obtained by repeating the operation using folic acid (RS) instead of the substance being examined and the declared content of $C_{19}H_{19}O_6N_7$ in folic acid (RS).

C. Glyceryl Trinitrate Tablets

Theory : First and foremost the active ingredient *i.e.*, glyceryl trinitrate is extracted completely from the tables by shaking with glacial acetic acid. To an aliquot of the resulting acetic acid solution an excess of phenoldisulphonic acid is added to produce a yellow colour which is subsequently intensified by adding an excess of ammonia. The following reactions take place :

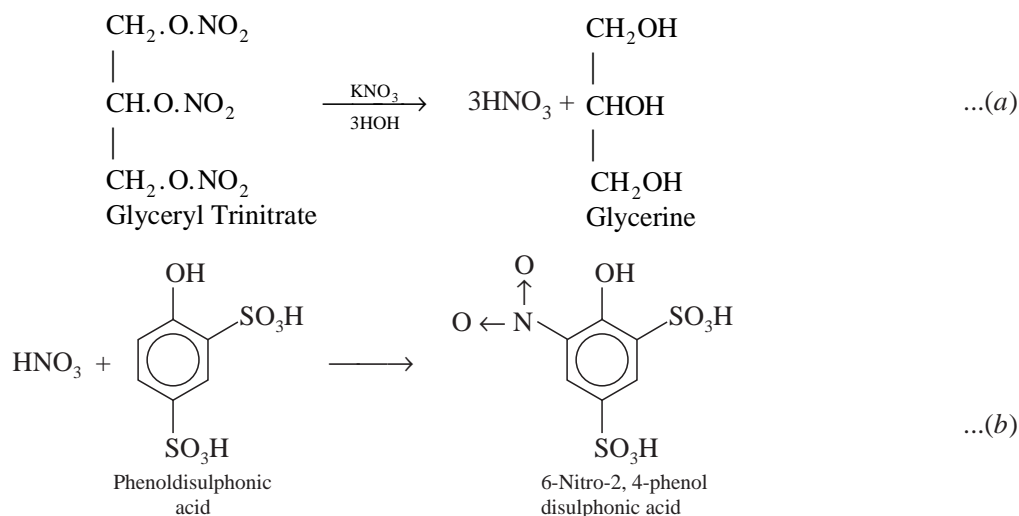

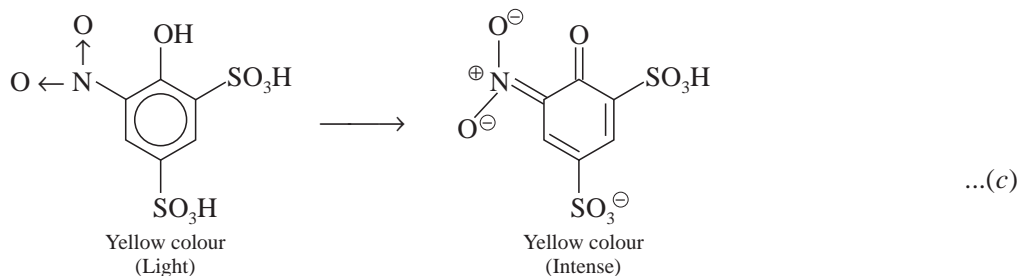

The standard substance in this assay is KNO_3 , which conforms to the nitric acid released by acidolysis in the test solution.

Materials Required : Glyceryl trinitrate tablets : 20 ; glacial acetic acid (90% v/v) : 5 ml ; phenoldisulphonic acid solution (heat 3 g of phenol with 20 ml of sulphuric acid on a water-bath for 6 hours, and transfer the resulting liquid to a stoppered vessel) : 2 ml ; strong ammonia solution ; 20 ml ; potassium nitrate (previously dried at 105°C) : 1 g ;

Procedure : Weigh and powder 20 tablets. Now, weigh accurately a quantity of the powder equivalent to 0.5 mg of glyceryl trinitrate, add 5 ml of glacial acetic acid, shake thoroughly for 1 hour and then centrifuge. To 2 ml of the supernatant liquid add 2 ml of phenoldisulphonic acid solution and allow to stand for 15 minutes. Add 8 ml of DW, make alkaline with strong ammonia solution, cool to about 20°C , dilute to 20 ml with DW and filter. Finally, measure the extinction of a 1-cm layer of the filtrate at 405 nm, as described earlier, employing as blank 2 ml of glacial acetic acid, treated exactly in a similar fashion, beginning at “add 2 ml of phenoldisulphonic acid solution”.

Dissolve 133.5 mg of potassium nitrate, in sufficient DW to produce 100 ml ; to 10 ml add sufficient glacial acetic acid to produce 100 ml. Taking 2 ml of this solution, just repeat the assay beginning the procedure at “add 2 ml of phenoldisulphonic acid solution.....”.

Calculations : We have : $\text{KNO}_3 \equiv \text{C}_3\text{H}_5\text{N}_3\text{O}_9$

or $101 \text{ g } \text{KNO}_3 \equiv 227 \text{ g of } \text{C}_3\text{H}_5\text{N}_3\text{O}_9$

or $101 \text{ g of } \text{KNO}_3 \equiv 227/3 \text{ g } \text{C}_3\text{H}_5\text{N}_3\text{O}_9^*$

or $\equiv 75.66 \text{ g of } \text{C}_3\text{H}_5\text{N}_3\text{O}_9$

or $1 \text{ ml } (\equiv 1.335 \text{ mg}) \text{ of } \text{KNO}_3 \equiv 0.1 \text{ mg of } \text{C}_3\text{H}_5\text{N}_3\text{O}_9$

The content of $\text{C}_3\text{H}_5\text{N}_3\text{O}_9$ may be calculated from the values of the extinctions thus obtained. Each ml of the potassium nitrate solution is equivalent to 0.1 mg of $\text{C}_3\text{H}_5\text{N}_3\text{O}_9$.

Cognate Assays : The following two pharmaceutical products, namely : Pentaerythritol tetranitrate Tablets and Diluted Isosorbide dinitrate are assayed by using a solution of phenoldisulphonic acid as detailed below :

S.No.	Name of Substance	Qty. Prescribed	Extinction (ϵ)	Calculation
1.	Pentaerythritol tetranitrate Tablets	50 mg	405 nm	Each ml of KNO_3 soln. \equiv 0.5 mg of $\text{C}_5\text{H}_8\text{N}_4\text{O}_{12}$
2.	Diluted Isosorbide dinitrate	25 mg	405 nm	Each ml of KNO_3 soln. \equiv 0.934 mg of $\text{C}_6\text{H}_8\text{N}_2\text{O}_8$

D. Stilboesterol

Theory : The assay of stilbonesterol is exclusively based upon photochemical reactions whereby the *trans*-isomer firstly gets converted into its corresponding *cis*-isomer (*Geometrical Isomerism*) and then followed by intramolecular rearrangement thereby causing ring closure as expressed in the (see next page) equations :

* Because glycerine has three replaceable-OH groups.

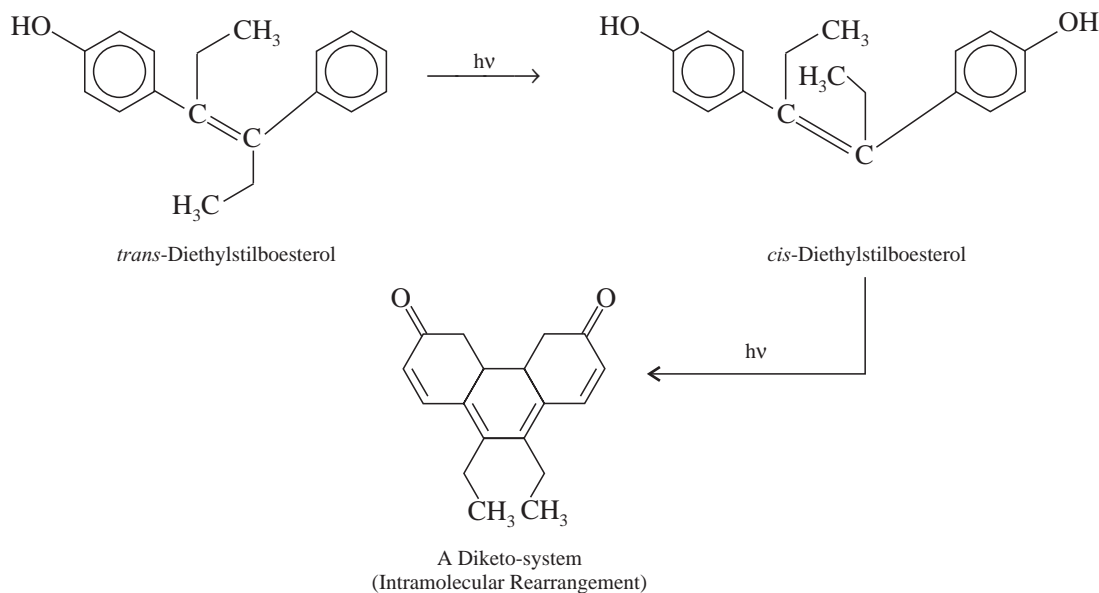

The highly conjugated diketo system obtained as a result of irradiation of the stilboesterol solution placed in a closed spectrophotometer cell for a duration of 10 minutes and exposed to a 15-watt short-wave ultraviolet lamp. Ultimately the extinction is duly measured at 418 nm and compared with stilboesterol (RS) treated exactly in the same manner.

Materials Required : Stilboesterol : 20 mg ; ethyl alcohol (absolute) : 250 ml ; dipotassium hydrogen phosphate solution (dissolve 1 g in 55 ml of DW) : 25 ml ;

Procedure : Weigh accurately about 20 mg of stilboesterol in sufficient ethyl alcohol to produce 100 ml ; and dilute 10 ml of this solution to 100 ml with ethyl alcohol. To 25 ml of the resulting solution add 25 ml of dipotassium hydrogen phosphate solution, transfer a portion of the mixture to a 1-cm closed quartz cell, place the cell 10 cm from a 15 watt short-wave UV-lamp, and subject it to irradiation for 10 minutes. Now, measure the extinction of the irradiated solution at the maximum at about 418 nm as described earlier.

Calculations : Calculate the content of $C_{18}H_{20}O_2$ from the extinction obtained by repeating the operation with stilboesterol (RS).

21.4.6. UV-ABSORPTION CHARACTERISTICS OF SOME OFFICIAL PHARMACEUTICAL SUBSTANCES

The ultra-violet absorption characteristics of a number of official pharmaceutical substances have been duly provided in Table 21.2.

Table 21.2 : UV-Absorption Characteristics of Pharmaceutical Substances

S.No.	Name of substance	Qty. Prescribed	Solvent Used	(nm)	E (1% ; 1-cm ;)
1.	Amodiaquine hydrochloride	0.3 g	0.1 N HCl	343	—
2.	Ampicillin	0.15 g	Water	325	—
3.	Betamethasone sodium phosphate	0.2 g	-do-	241	391 (as Betamethasone)
4.	Carbamazepine	0.1 g	Alcohol (95%)	285	490
5.	Carbimazole	50 mg	Water/0.1 N HCl	291	557
6.	Chloramphenicol	0.125 g	Water	278	288
7.	Chloramphenicol Palmitate	60 mg	Ethyl Alcohol	271	178
8.	Cyanocobalamine	25 mg	Water	361	207

9.	Deslanoside	30 mg	Methanol	490	—
10.	Dexamethasone Sodium Phosphate	0.2 g	Water	241	297
11.	Digitoxin	40 mg	Ethanol	495	—
12.	Dithranol	20 mg	Glacial Acetic Acid	450	550
13.	Ergotamine Tartrate	10 mg	Tartaric Acid (1% w/v)	578	—
14.	Ethinylestradiol	150 mcg	Methanol	538	—
15.	Ethipropazine HCl Tablets	50 mg	Ethanol (95%)	252	845
16.	Griseofulvin	80 mg	Ethanol	291	686
17.	Imipramine HCl Tablets	75 mg	0.1 N HCl	250	264
18.	Indomethacin Capsules	50 mg	Methanol	318	193
19.	Isoprenaline HCl Injection	5 mg	Water	540	—
20.	Isoprenaline Tablets	0.1 g	Water	540	—
21.	Isoxsuprine HCl	50 mg	Water	269	71.5
22.	Lanatoside-C	0.03 g	Methanol	490	—
23.	Megestrol Acetate	10 mg	Ethanol	287	630
24.	Methandienone	50 mg	-do-	245	516
25.	Methadilazine HCl	0.1 g	Water	275	—
26.	Methylergometrine Maleate	20 mg	Water	550	—
27.	Nalidixic Acid Tablets	0.1 g	N . NaOH	258	1120
28.	Nalorphine HCl	25 mg	Water	285	—
29.	Nandrolone Decanoate	10 mg	Ethanol	239	407
30.	Nandrolone Phenylpropionate	10 mg	Ethanol	240	430
31.	Nicoumalone Tablet	1 mg	Methanol	306	521
32.	Nitrofurantoin	0.12 g	DMF/Acetate Buffer	367	765
33.	Nitrofurazone	0.1 g	DMF/Water	375	822
34.	Oestradiol Benzoate	10 mg	Ethanol	231	490
35.	Oestradiol Dipropionate	40 mg	Methanol	520	—
36.	Oxprenolol Tablets	20 mg	Water/Methylene Chloride	273	74.5
37.	Oxyphenonium Bromide Tablets	20 mg	Water	620	—
38.	Phenylephrine HCl Injection	50 mg	NH ₂ SO ₄	273	95
39.	Psoralen	0.1 g	Methanol	247	—
40.	Riboflavine Phosphate Sodium	0.1 g	Water/Acetate Buffer	444	323
41.	Rifampicin	0.1 g	Methanol	475	187
42.	Sodium Cromoglycate	0.1 g	Buffer Soln. (pH 7.4)	326	164
43.	Spironolactone	10 mg	Methanol	238	470
44.	Stilboesterol Diphosphate	0.1 g	Ethanol/Water	241	—
45.	Testosterone Propionate	10 mg	Ethanol	241	490
46.	Triamcinolone Acetonide	25 mg	-do-	240	354
47.	Tubocurarine Chloride	25 mg	Water	280	105

THEORETICAL AND PRACTICAL EXERCISES

1. Give a brief and comprehensive account of the following terminologies :
 - (a) Electromagnetic spectrum,
 - (b) Molar absorptivity,
 - (c) Absorption spectra,
 - (d) Structural features, and
 - (e) Absorption bands.
2. (a) What are the **four** motion-related energies exhibited by a '**drug molecule**' ? Explain.
(b) Enumerate the **three** distinct situations that may arise in the transformation of an '**excited electron**' to its '**ground state**'. Give suitable examples, wherever necessary, to support your answer.
3. (a) Discuss the various salient features of '**potential energy**' of a *diatomic molecule* diagrammatically.
(b) What are the various factors that essentially influence the absorption of radiant energy ? Explain with typical examples.
4. (a) Why a '**double-beam**' **spectrophotometer** gives more precise, reliable and reproducible results in comparison to a '**single-beam**' **spectrophotometer** ? Explain.
(b) Describe an UV-Spectrophotometer with a neat-labelled block diagram and explain its operational mode.
5. Discuss the theory, procedure and calculations for the assay of the following medicinal compounds :
 - (i) Folic acid,
 - (ii) Glyceryl trinitrate tablets, and
 - (iii) *Trans*-Diethylstilbesterol.
6. UV-Spectrophotometric method employed for the assay of the following '**drug substances**' :
 - (i) Ampicillin,
 - (ii) Ergotamine tartrate,
 - (iii) Nalorphine hydrochloride,
 - (iv) Nitrofurazone,
 - (v) Rifampicin, and
 - (vi) Spironolactone.

RECOMMENDED READINGS

1. Jaffe, H.H. and M. Orchin., '**Theory and Applications of Ultraviolet Spectroscopy**', New York, Wiley, 1962.
2. IUPACC Commission on Spectrochemical and other Optical Procedures for Analysis **Spectrophotometric Data for Colorimetric Analysis**, London, Butterworth Publishers Ltd., 1963.
3. West, W., (Ed.), '**Techniques of Organic Chemistry**', Vol. IX., **In Chemical Applications of Spectroscopy**, 2nd ed., New York, Interscience, 1968.
4. Rao, C.N.R., '**Ultraviolet and Visible Spectroscopy**', London, Butterworths, 1975.
5. Knowles, A. and C. Burgess, Eds., '**Practical Absorption Spectrometry**', New York, Chapman and Hall, 1984.
6. Alremore, I.R., '**Evaluation of Instrumentation for UV-Visible Spectrophotometry**', *J. Chem. Educ.*, **63** : A 216, 1986.
7. Day, R.A. Jr. and A.L. Underwood., '**Quantitative analysis**', 6th ed., New Delhi, Prentice-Hall of India Pvt. Ltd., 1993.

22

INFRARED SPECTROPHOTOMETRY

CONTAINS :

- 22.1 Introduction
 - 22.1.1 Group frequency region
 - 22.1.2 Fingerprint region
- 22.2 Theory
 - 22.2.1 Molecular vibrations
 - 22.2.2 Factors influencing vibrational frequencies
- 22.3 Instrumentation
 - 22.3.1 Single monochromator infrared spectrophotometer
 - 22.3.2 Double monochromator infrared spectrophotometer
- 22.4 Applications of IR-spectroscopy in pharmaceutical assays
 - 22.4.1 Applications of IR-spectroscopy in the analysis of pharmaceutical substances
 - 22.4.2 Applications of IR-spectroscopy in the analysis of pharmaceutical dosage forms
- 22.5 Applications of IR-spectroscopy in analytical chemistry
 - 22.5.1 Determination of *cis-trans* isomer ratio in clomiphene citrate
 - 22.5.2 To distinguish and characterize the pri-, sec-, and tert-amine salts from one another
 - 22.5.3 IR-spectroscopy in the study of complex formations
 - 22.5.4 IR-spectroscopy in quantitative reaction sequence study
 - 22.5.5 IR-spectroscopy in the identification of functional groups
 - 22.5.6 IR-spectroscopy : Identification by fingerprinting
 - 22.5.7 Interpretation of IR-spectrum

22.1. INTRODUCTION

The **infrared spectrum** provides the largest number of characteristic properties of a compound. It also serves as a powerful '*analytical tool*' for the extensive and intensive study of molecular structure.

In fact, **infrared absorption spectra** are due to changes in vibrational energy accompanied by changes in rotational energy. Broadly speaking, the range in the electromagnetic spectrum that extends from 0.8 to 200 μ is referred to as the infrared region. In usual practice, however, either the wavelength (μ) or the wave number (cm^{-1}) is employed to measure the position of a given infrared absorption. More precisely, the infrared regions may be categorized into three distinct zones based on their respective wave numbers and wavelengths as stated below :

S. No.	Region	Wave Number (cm^{-1})	Wavelength (μ)
1.	Ordinary Infrared	4000-667	2.5-15
2.	Near Infrared	12,500-4,000	0.8-2.5
3.	Far Infrared	667-50	15-200

Besides, the infrared region is found to be normally rich in peaks by virtue of the fact that there exist a number of vibrational modes ($3n-6$, where, n = number of atoms for any nonlinear molecule).

Another school of thought advocates that there are two general regions in the infrared spectrum, namely : (a) **Group frequency region** : having a wavelength ranging from 2.5 to 8.0 μ and a wave number from 4000-1300 cm^{-1} ; (b) **Fingerprint region** : having a wavelength ranging from 8.0-2.5 μ and a wave number from 1300-400 cm^{-1} .

22.1.1. GROUP FREQUENCY REGION

Here, the stretching and bending vibrational bands associated with specific structural or functional groups are observed frequently.

Example : The C = O stretching frequency is about 1700 cm^{-1} ; whereas the C—H stretching frequency is about 3000 cm^{-1} and both of them are almost independent of the rest of the molecule as depicted in Table 22.1.

Table 22.1 : Stretching Frequencies found in Group Frequency Region

C—H Stretch			C = O Stretch		
S. No.	Molecule	Frequency (cm^{-1})	S. No.	Molecule	Frequency (cm^{-1})
1.	CHCl_3	3019	1.	CH_3COCH_3	1715
2.	$\text{C}_2\text{H}_2\text{Cl}_2$	3089	2.	CH_3CHO	1729
3.	$\text{CH}_2 = \text{CH}_2$	3105, 2990	3.	$\text{H}_5\text{C}_2\text{COC}_2\text{H}_5$	1720
4.	C_6H_6	3099	4.	HCOOH	1729
5.	CH_3OH	2977	5.	CH_3COOH	1718
6.	$\text{CH} \equiv \text{CH}$	3287	6.	CF_3COOH	1776

22.1.2. FINGERPRINT REGION

Here, the vibrational modes depend solely and strongly on the rest of the molecule.

Example : The C—C stretching frequency depends largely on what else is bonded to the carbon atoms.

It is interesting to observe here that this particular region of the spectrum is densely populated with bands. As we know that no two ‘fingerprints’ could be identical in human beings, exactly in a similar manner no two compounds may have the same ‘fingerprint region’. Thus, each and every molecule essentially gives rise to a unique spectrum which offers a characteristic feature of the same.

22.2. THEORY

The underlying principle of infrared spectroscopy is based upon the molecular vibrations which is further composed of the stretching and the bending vibrations of a molecule.

Therefore, it would be necessary to have a clear concept of various modes of vibrations often encountered in different molecules having a variety of functional moieties, laws governing them and the mathematical derivations related to them.

22.2.1. MOLECULAR VIBRATIONS

A molecule may not be looked upon as a rigid assemblage of atoms. Rather it may be regarded as a sort of flexible system comprising of balls of varying masses representing the atoms of a molecule and springs of varying strengths representing the chemical bonds of a molecule.

The vibrations for molecules are of *two* types, namely :

- (a) Stretching, and
- (b) Bending (or deformation).

22.2.1.1. Stretching

Vibration causes stretching whereby the distance between the two atoms increases or decreases, but the atoms remain in the same bond axis.

22.2.1.2. Bending (or Deformation)

Vibration causes bending whereby the position of the atom changes relative to the original bond axis.

Therefore, the various stretching and bending vibrations of a bond usually take place at particular quantized frequencies. Thus, in a situation where upon the infrared light having the same frequency is incident on the molecule, energy is absorbed, and the net effect could be observed by an increase in the amplitude of that vibration. In another situation, whereby the molecule reverts from the excited state to the ground state, the absorbed energy is released in the form of heat.

The various stretching and bending vibrations that can exist within a molecule may be represented schematically as shown below in Figure 22.1 :

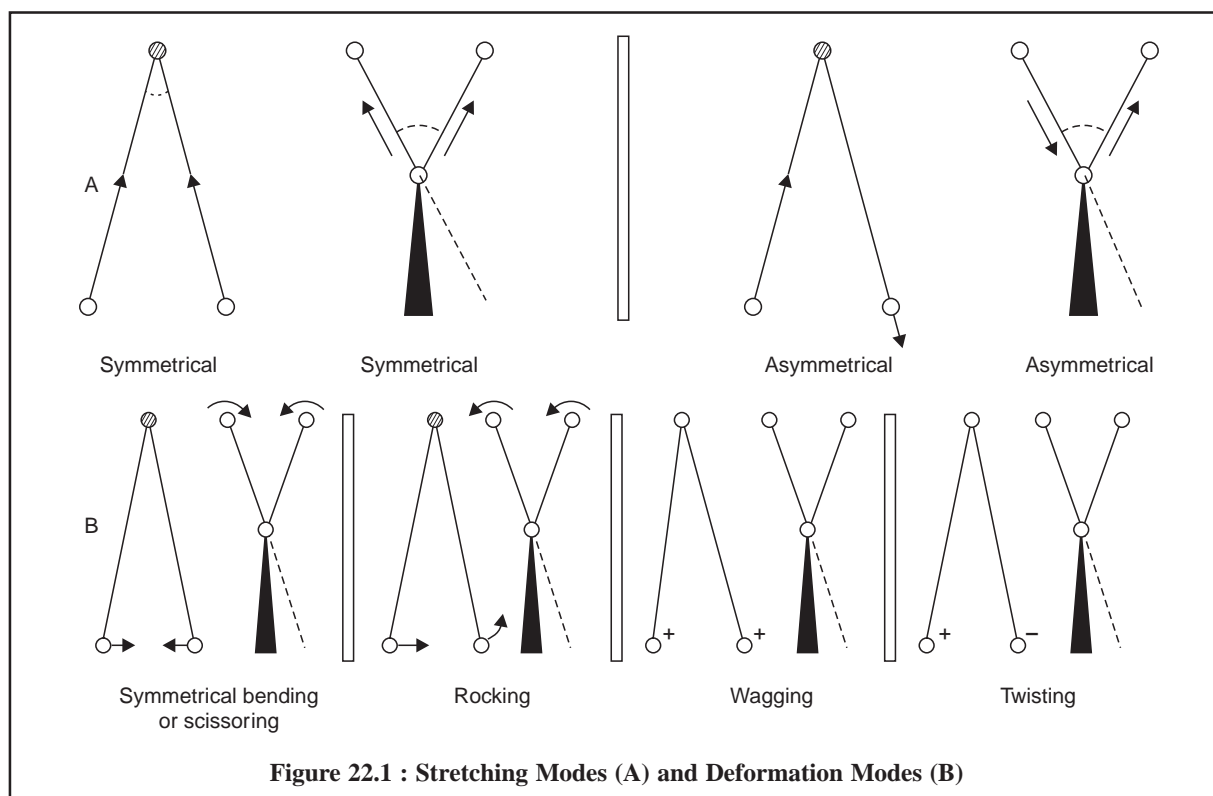

There are *two* types of Bending (or deformation) Modes, namely :

- (i) Below the plane of paper and perpendicular to it designated by (+) sign, and
- (ii) Above the plane of paper and perpendicular to it represented by (-) sign.

22.2.1.3. Stretching Vibrations

In this particular instance, the atoms move invariably along the bond that joins them *e.g.*, C—H ; C = O ; O—H ; N—H.

The stretching vibrations may be further sub-divided into *two* categories, namely :

- (a) **Symmetrical Stretching** : In this case, the two hydrogen atoms either move towards or away from the central carbon atom in unison, thereby either altering the interatomic distance or causing no change in valence angle (Figure 22.1).

(b) **Asymmetrical Stretching** : In this instance, one hydrogen atom approaches the carbon atom while the other moves away from the carbon atom (Figure 22.1).

22.2.1.4. Bending (or Deformation) Vibrations

In the event when a three-atom system forms part of a larger molecule, it is quite possible to have bending (or deformation) vibrations which essentially involve oscillation of the atoms, or group as a whole and is perpendicular to its chemical bond (Figure 22.1).

Such bending vibrations can take place either in-plane or out-of-plane.

22.2.1.4.1. In-Plane Bending Vibrations

These are *two* types :

- (a) **Scissoring or Symmetrical Bending** : In this case, the two atoms connected to a central atom either move toward or away from each other with certain deformation of the valence angle.
- (b) **Rocking** : In this case, the structural unit swings back and forth in the plane of the molecule.

22.2.1.4.2. Out-of Plane Bending Vibrations

These are also of *two* kinds, namely :

- (a) **Wagging** : In this case the structural unit swings back and forth out of the plane of the molecule.
- (b) **Twisting** : In this case the structural unit rotates about the bond that joins it to the rest of the molecule.

22.2.1.4.3. Explanations of Bending and Stretching Vibrations

The bending (or deformation) vibrations generally require less energy and take place at longer-wavelength than the corresponding stretching vibrations.

In contrast, the stretching vibrations are observed to occur with respect to their corresponding bond-strengths.

Examples : The typical examples of triple-bond, double-bond and single-bond are given below :

S. No.	Type of Bond	Examples	Force Constants (dynes/cm)	Absorption At	
				Wavelength (μ)	Frequency (cm^{-1})
1.	Triple Bond	$\text{C} \equiv \text{C}$; $\text{C} \equiv \text{N}$;	15×10^5	4.4-5.0	2300-2000
2.	Double Bond	$\text{C} = \text{O}$; $\text{C} = \text{C}$; $\text{C} = \text{NH}$;	10×10^5	5.3-6.7	1900-1500
3.	Single Bond	$\text{C}-\text{C}$; $\text{C}-\text{OH}$; $\text{C}-\text{N}$;	5×10^5	7.7-12.5	1300-800

Whenever a very small proton like : $\text{C}-\text{H}$; $\text{O}-\text{H}$; or $\text{N}-\text{H}$ is involved in a single bond, the stretching vibrations normally take place at much higher frequency *i.e.*, $3700-2630 \text{ cm}^{-1}$ (or $2.7-3.8 \mu$). It is, however, interesting to note that $\text{O}-\text{H}$ bond absorbs at 2.8μ (or 3570 cm^{-1}), whereas $\text{O}-\text{D}$ bond absorbs at 3.8μ (or 2630 cm^{-1}). In this specific case, the strengths of the two bonds are more or less the same, but the mass of one atom is almost doubled.

22.2.1.4.4. Calculation of Vibrational Frequencies

The vibrational frequency may be calculated with fairly remarkable accuracy by the help of Hooke's Law and is expressed as :

$$\nu = \frac{1}{2\pi} \left(\frac{k}{m_1 m_2 / (m_1 + m_2)} \right)^{\frac{1}{2}} \quad \dots(a)$$

where, ν = Frequency,
 k = Force constant of the bond, and
 m_1 and m_2 = Masses of two atoms.

The quantity $m_1 m_2 / (m_1 + m_2)$ is often expressed as μ , the reduced mass of the system.

Example : Calculate the approximate frequency of the C—H stretching vibration from the following data :

$$k = 500 \text{ Nm}^{-1} = 5.0 \times 10^5 \text{ gs}^{-2} \text{ (since 1 newton = } 10^3 \text{ gm s}^{-2}\text{) ;}$$

$$m_c = \text{mass of the carbon atom} = 20 \times 10^{-24} \text{ g ;}$$

$$m_H = \text{mass of the hydrogen atom} = 1.6 \times 10^{-24} \text{ g ;}$$

Solution : By putting the values of k , m_1 and m_2 in Eq. (a) we have :

$$\nu = \frac{7}{2 \times 22} \left(\frac{5.0 \times 10^5 \text{ gs}^{-2}}{(20 \times 10^{-24} \text{ g})(1.6 \times 10^{-24} \text{ g})(20 + 1.6) 10^{-24} \text{ g}} \right)^{\frac{1}{2}}$$

or $\nu = 9.3 \times 10^{13} \text{ s}^{-1}$

Using the relationship between frequency and wave number, we have :

$$\bar{\nu} = \nu/c$$

where, $\bar{\nu}$ = Wave number,

ν = Frequency, and

c = Velocity of light ($\cong 2.998 \times 10^8 \text{ ms}^{-1}$)

Therefore, we have :

$$\bar{\nu} = \frac{\nu}{c} = \frac{9.3 \times 10^{13} \text{ s}^{-1}}{3.0 \times 10^8 \text{ ms}^{-1}}$$

or $= 3.1 \times 10^5 \text{ cm}^{-1}$

or $= 3100 \text{ cm}^{-1}$

However, it is pertinent to restate the underlying principles embodied in these calculations, that is **“the vibrational frequency of a bond is expected to increase when the bond strength increases, and also when the reduced mass of the system decreases”**.

22.2.1.5. Salient Features of IR-Spectroscopy

There are, in fact, *three* vital points that may be noted with regard to IR-spectroscopy, namely :

- Most intense peaks in the IR-spectrum are solely due to absorption peaks caused by the stretching vibrations,
- Molar extinction coefficient in IR-spectroscopy varies from 0-2000 cm^{-1} , and
- Molar extinction coefficient is directly proportional to the square of the change in the dipole moment* of the molecule that the particular vibration affords.

22.2.2. FACTORS INFLUENCING VIBRATIONAL FREQUENCIES

There are a number of factors that influence the precise frequency of a molecular vibration, namely :

- Vibrational coupling,
- Hydrogen bonding,

* Dipole Moment = Electric charge \times Distance between the charges

or $\mu = e \times d = 10^{-10} \text{ e.s.u.} \times 10^{-8} \text{ cm} = 10^{-18} \text{ esu cm (or D)}$

The unit of Dipole Moment is DEBYE (D) after the name of the researcher.

(c) Electronic Effects, and

(d) Field Effects.

All the above factors shall be discussed briefly with appropriate examples and explanations, wherever necessary, below :

22.2.2.1. Vibrational Coupling

The following four vibrations may be observed in the high-resolution spectra of compounds containing both $-\text{CH}_2$ and $-\text{CH}_3$ groups.

$\text{C}-\text{H}$: One stretching frequency,

$\begin{array}{c} \text{H}-\text{C} \\ | \\ \text{H} \end{array}$: Two coupled vibrations having different frequencies *i.e.*, ν_{anti} and ν_{symm} (for asymmetric and symmetric), and

$\begin{array}{c} \text{H} \\ | \\ \text{H}-\text{C} \\ | \\ \text{H} \end{array}$: Equivalent coupled vibration.

Examples : The *three* typical examples are described below, namely :

(a) **Carboxylic Acid Anhydrides :** For instance :

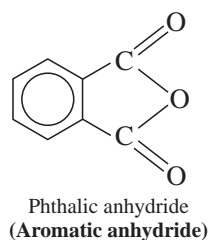
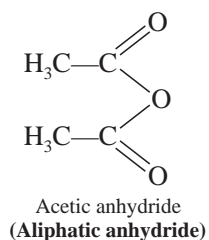

Following are the salient features :

- It affords two $\text{C}=\text{O}$ stretching absorptions *viz.*, ν_{anti} and ν_{symm} between frequency $1800\text{-}1900\text{ cm}^{-1}$ having a separation of about 65 cm^{-1} ;
- The coupling solely occurs between the two carbonyl groups, that are indirectly linked through $-\text{O}-$;
- **Resonance :** The interaction is probably encouraged due to the single as well as double-bond character prevailing in the carbonyl-oxygen bonds brought about by resonance as shown below :

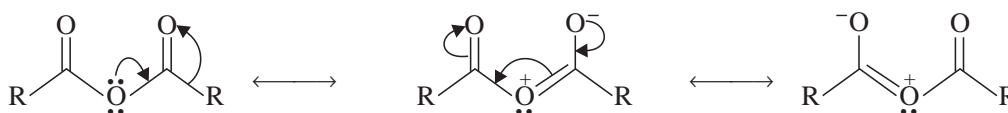

Anhydrides : Various resonance forms

(b) **Amides** ($-\overset{\text{O}}{\parallel}{\text{C}}-\text{NH}_2$) : The functional moiety 'amide' shows two distinct bands around $1600\text{-}1700\text{ cm}^{-1}$ caused due to $\text{C}=\text{O}$ str. and $\text{N}-\text{H}$ def. These bands are also known as Amide-I and Amide-II bands.

- (c) **Carboxylic Acids** : Let us consider the example of benzoic acid IR-spectrum in KBr-disc wherein we may observe a relatively broad band caused due to hydrogen-bonded O—H str. between 2500-3500 cm^{-1} . These broad bands are formed due to the dimeric and polymeric associations of benzoic acid as shown below :

Dimeric Association :

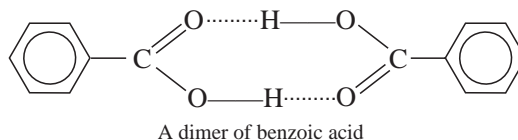

Polymeric Association :

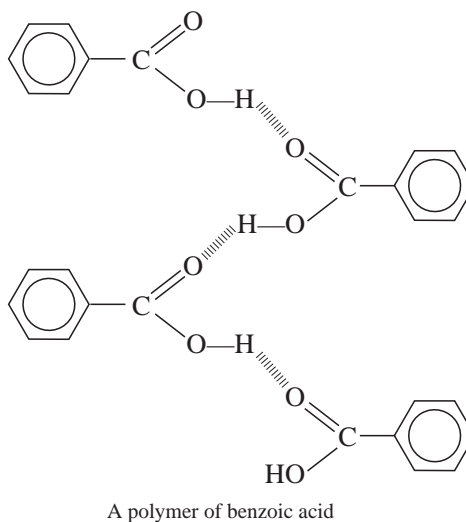

- (d) **π -Cloud Interactions** : Since alkene and aromatic π -bonds behave as Lewis bases, they may form hydrogen bonds to acidic hydrogens *e.g.*,

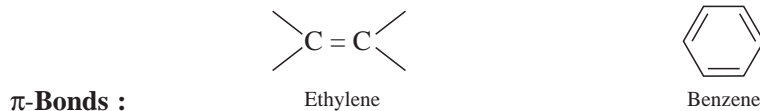

Example : The frequency of O—H str. in phenols is lowered by 40-100 cm^{-1} when the IR-spectrum is recorded in a benzene solution as compared to a carbon tetrachloride solution.

- (e) **Amines** : Amines usually show two distinct bands due to N—H stretching in different environments. In condensed-phase spectra, amines show **bonded N—H** str. around 3300 cm^{-1} and in dilute solution a new band near 3600 cm^{-1} corresponding to free N—H str. It may be attributed due to the fact that the electronegativity of nitrogen is less than that of oxygen and hence the hydrogen bonds in amines are weaker than in alcohols.

22.2.2.3. Electronic Effects

On the basis of theoretical principles one may explain the frequency shifts that normally take place in molecular vibrations when the substituents are altered :

A few such classical examples are enumerated with appropriate explanations.

- (a) **Conjugation Effect** : It is observed to lower the frequency of both C = C str. and C = O str., irrespective of the fact it is brought about by either $\alpha\beta$ -unsaturation or by an aromatic ring as shown below :

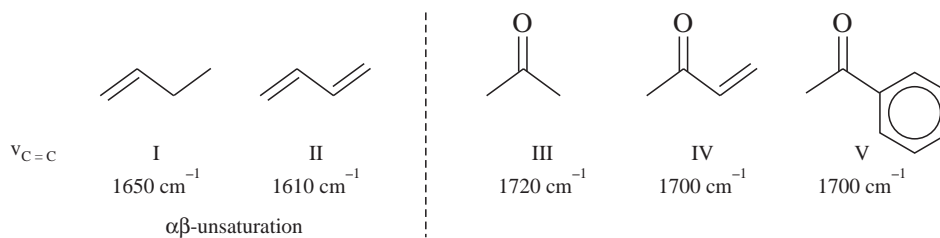

Explanation : In II, lowering of band order in the C = C bond is observed due to conjugation effect whereby the stretching vibration frequency is decreased by 40-50 cm^{-1} (compare I and II above). In a similar manner, in V delocalization of π -electrons between C = O and the benzene ring enhances the double-bond character of the bond joining the C = O to the ring. It ultimately leads to a lower band order in the C = O bond thereby decreasing the stretching vibration frequency by 20-30 cm^{-1} (compare III and V above).

(b) **Mesomeric (or Resonance) Effect :** Whenever a molecule can be represented by two or more structures that differ only in the arrangement of electrons—that is, by structures that have the same arrangement of atomic nuclei—there is resonance.

It may be further expatiated with the help of the following typical examples :

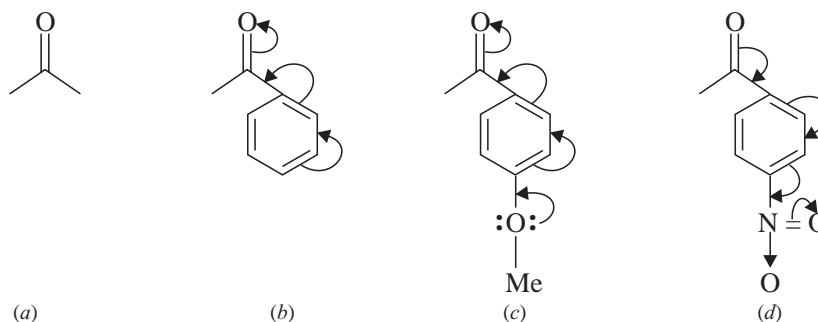

—OMe : Electron Releasing Moiety

—NO₂ : Electron Withdrawing Moiety

In (b) above, the presence of a phenyl ring increases the *mesomeric shift* thereby lowering C = O str. frequency.

+ **M Group** : viz., *p*-OMe (an electron releasing function)—its presence as depicted in (c) above will further lower frequencies due to *enhanced mesomeric effect*.

– **M Group** : viz., *p*-NO₂ (an electron withdrawing function)—its presence as shown in (d) above will further increase frequencies due to *decreased mesomeric effect*.

(c) **Inductive Effects :** The inductive effects solely depends upon the ‘intrinsic’ tendency of a substituent to either release or withdraw electrons—by definition, its electronegativity acting either through the molecular chain or through space. This effect usually weakens steadily with increasing distance from the substituent.

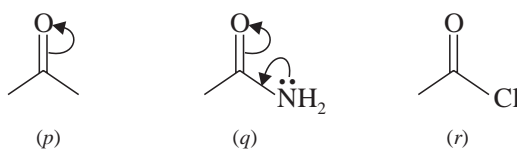

The 'inductive effects' shall now be discussed specifically with regard to the various functional moieties such as : amides, acyl chlorides, alkyl esters and aryl esters :

- (i) **Amides** : (*q*), The + M effect causes weakening of the C = O bond, leading to the corresponding ketone (*p*). In this particular instance, the – I effect of nitrogen is being dominated by + M effect.
- (ii) **Acyl Chlorides** : (*r*), the – I effect of Cl is more effective than + M effect, thereby causing an opposite shift (to higher frequency).

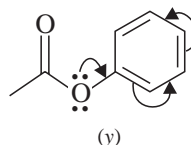
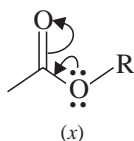

- (iii) **Alkyl Esters** : (*x*), it has been observed that a conflict between I and M effects invariably takes place in the case of esters. Here, the non-bonding electrons residing on oxygen enhance the + M conjugation thereby decreasing the C = O frequency.
- (iv) **Aryl Esters** : (*y*), here the non-bonding electrons located on oxygen are partially drawn into the benzene ring and thereafter their conjugation with C = O is minimised. The net effect would be that – I effect of oxygen becomes dominant and consequently C = O moves to a higher frequency.
- (d) **Field Effects** : It has been observed that two functional groups often influence each other's vibrational frequencies by a through-space interaction that may be either steric and/or electrostatic in nature.

A typical example of *ortho*-chlorobenzoic acid esters is shown below :

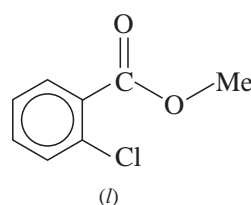
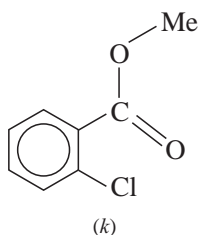

In the above instance, the field effect shifts the C = O frequency in the rotational isomer (*k*) and not in the isomer (*l*). As both isomers are usually found to be present together, therefore, two C = O str. absorptions are observed in the spectrum of this compound.

The various aspects discussed above in Sections 22.2.1 to 22.2.2.3, give a sufficient in-depth knowledge of theoretical considerations related to the better understanding of infrared spectroscopy.

22.3. INSTRUMENTATION

The infrared spectrophotometers are based on either single monochromation or double monochromation :

- (a) Single-Monochromator Infrared Spectrophotometer, and
 (b) Double-Monochromator Infrared Spectrophotometer.

The optical diagrams, components used and their modes of operation shall be discussed briefly in this context under different heads.

22.3.1. SINGLE MONOCHROMATOR INFRARED SPECTROPHOTOMETERS

The important features of an infrared spectrophotometer are as follows :

- (i) Infrared sources,
- (ii) Monochromators,
- (iii) Detectors, and
- (iv) Mode of Operation.

22.3.1.1. Infrared Sources

The most common infrared sources are electrically heated rods of the following types :

- (a) Sintered mixtures of the oxides of Zirconium (Zr), Yttrium (Y), Erbium (Er) etc., also known as '**Nernst Glower**',
- (b) Silicon Carbide '**Globar**', and
- (c) Various ceramic (clay) materials.

It is quite evident that the infrared output from all these different sources invariably varies in intensity over a definite frequency range, therefore, a compensating variable slit is usually programmed to operate in unison with the scanning over the individual frequencies.

22.3.1.2. Monochromators

Three types of substances are normally employed as monochromators, namely :

- (i) **Metal Halide Prisms** : Various metal halide prisms, such as : KBr (12-25 μm), LiF (0.2-6 μm) and CeBr (15-38 μm) have been used earlier, but they have become more or less obsolescent nowadays.
- (ii) **NaCl Prism (2-15 μm)** : Sodium chloride prism are of use for the whole of the region from 4000-650 cm^{-1} . First, it offers low resolution at 4000-2500 cm^{-1} , and secondly, because of its hygroscopic nature the optics have got to be protected at 20 $^{\circ}\text{C}$ above the ambient temperature.
- (iii) **Gratings** : In general, gratings are commonly employed in the design of the instruments and offer better resolution at higher frequency than the prisms. They offer much better resolution at low frequency, viz., typical rulings are 240 lines per nm for the 4000-1500 cm^{-1} region and 120 lines per nm for the 1500-650 cm^{-1} region.

22.3.1.3. Detectors

There are on all *three* different types of detectors that are used in the infrared region :

- (a) **Thermocouples (or Thermopiles)** : The underlying principle of a thermocouple is that if two dissimilar metal wires are joined head to tail, then a difference in temperature between head and tail causes a current to flow in the wires. In the infrared spectrophotometer this current shall be directly proportional to the intensity of radiation falling on the thermocouple. Hence, the thermocouples are invariably employed in the infrared region, and to help in the complete absorption of 'available energy' the 'hot' junction or receiver is normally blackened.
- (b) **Golay Detector** : In this specific instance the absorption of infrared radiation affords expansion of an inert gas in a cell-chamber. One wall of the cell-chamber is provided with a flexible mirror and the resulting distortion alters the intensity of illumination falling on a photocell from a reflected beam of light. Thus, the current from the photocell is directly proportional to the incident radiation.
- (c) **Bolometers** : These are based on the principle that make use of the increase in resistance of a metal with increase in temperature. For instance, when the two platinum foils are appropriately incorporated into a Wheatstone bridge, and radiation is allowed to fall on the foil, a change in the resistance is observed ultimately. This causes an out-of-balance current that is directly proportional to the incidental radiation. Just like the thermocouples, they are used in the infrared region.

22.3.1.4. Mode of Operation

The schematic layout of a single-monochromator infrared spectrophotometer has been duly depicted in Figure 22.2.

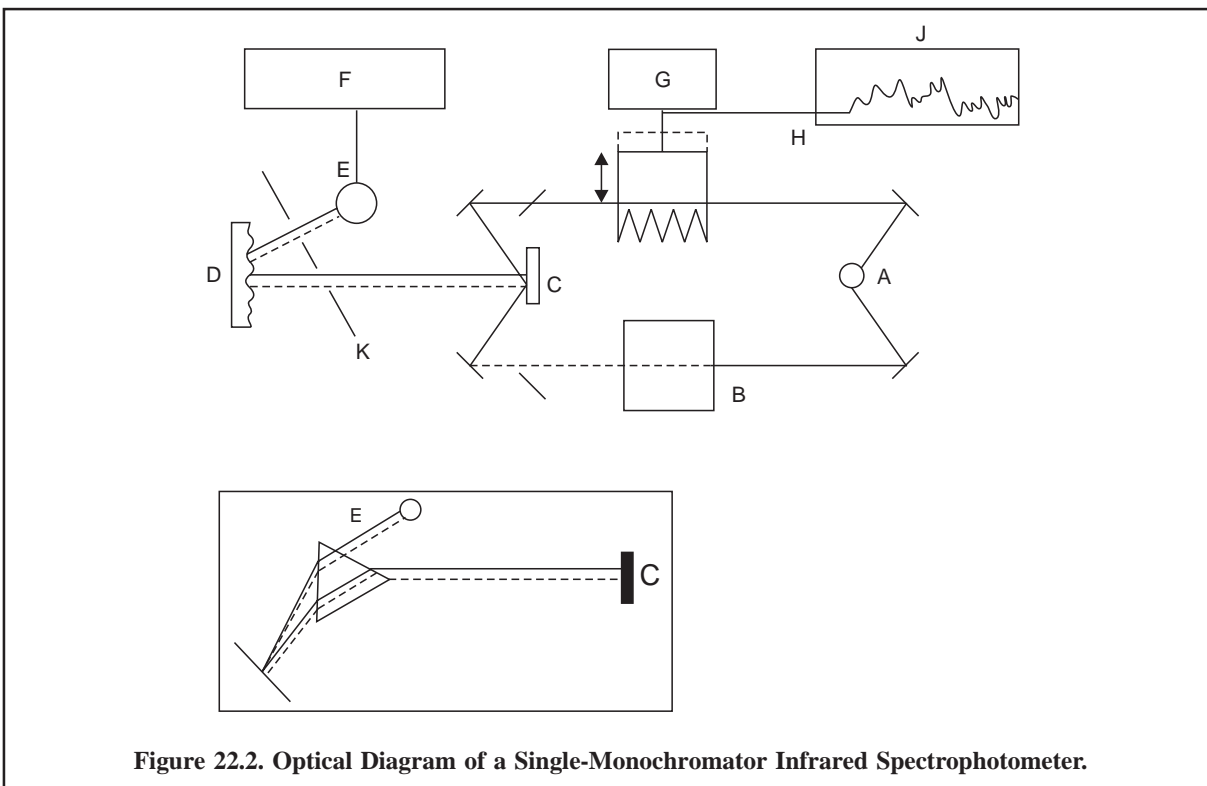

Figure 22.2. Optical Diagram of a Single-Monochromator Infrared Spectrophotometer.

The various vital components of Figure 22.2 are as follows :

- A = Infrared source,
- B = Sample beam,
- C = Chopper—a rotating segmented mirror,
- D = Monochromator grating,
- E = Detector thermopile,
- F = Amplifier,
- G = Servo-motor,
- H = An optical Wedge,
- I = Prism,
- J = Ink-pen recorder, and
- K = Slits.

The sequential steps observed in the mode of operation are as stated below :

- (i) The light from infrared source A is split equally into two beams ; one of which B is made to pass through the sample *i.e.*, the sample beam while the other serves as reference beam.

The main objective of such a double beam operation is to measure the difference in intensities between the two beams at each wave length.

- (ii) The two beams are subsequently reflected on a rotating segmented mirror called chopper C. The chopper rotating ≈ 10 times per second helps the sample beam and the reference beam to be reflected alternatively to the monochromator grating D.
- (iii) Thus, the grating rotates slowly and transmits individual frequencies to the detector thermopile (E), that consequently converts the infrared (thermal) energy to the corresponding electrical energy.
- (iv) When a sample has absorbed a certain quantum of light of specific frequency the detector shall be receiving alternatively from the chopper an intense beam (due to reference beam) and a relatively weak beam (due to sample beam). It will generate a pulsating or alternating current (AC) flowing from the detector to the amplifier F.
- (v) This out-of-balance signal received by the amplifier, is coupled to a small servo-motor G, that drives an optical wedge (H) into the reference beam until the detector receives light of equal intensity from sample and reference beams.
- (vi) The slightest movement of the wedge (or attenuator) is further coupled to a ink-pen recorder J, so that movement of the former, both 'in' and 'out' of the reference beam, is adequately recorded on the printed chart at various absorption bands.

This specific type of the **'double-beam optical-null recording spectrophotometer'** is termed so because it critically balances out by the help of optical means the differential between the two beams.

The 'inset diagram' in Figure 22.2 shows the use of a **'prism'** in place of the **'grating'**. However, underlying principle being identical, a rotating mirror affords the scanning of individual frequencies.

22.3.2. DOUBLE-MONOCHROMATOR INFRARED SPECTROPHOTOMETER

The schematic optical diagram of a double-beam infrared spectrophotometer has been shown in Figure 22.3 as per Beckman Model IR-9.

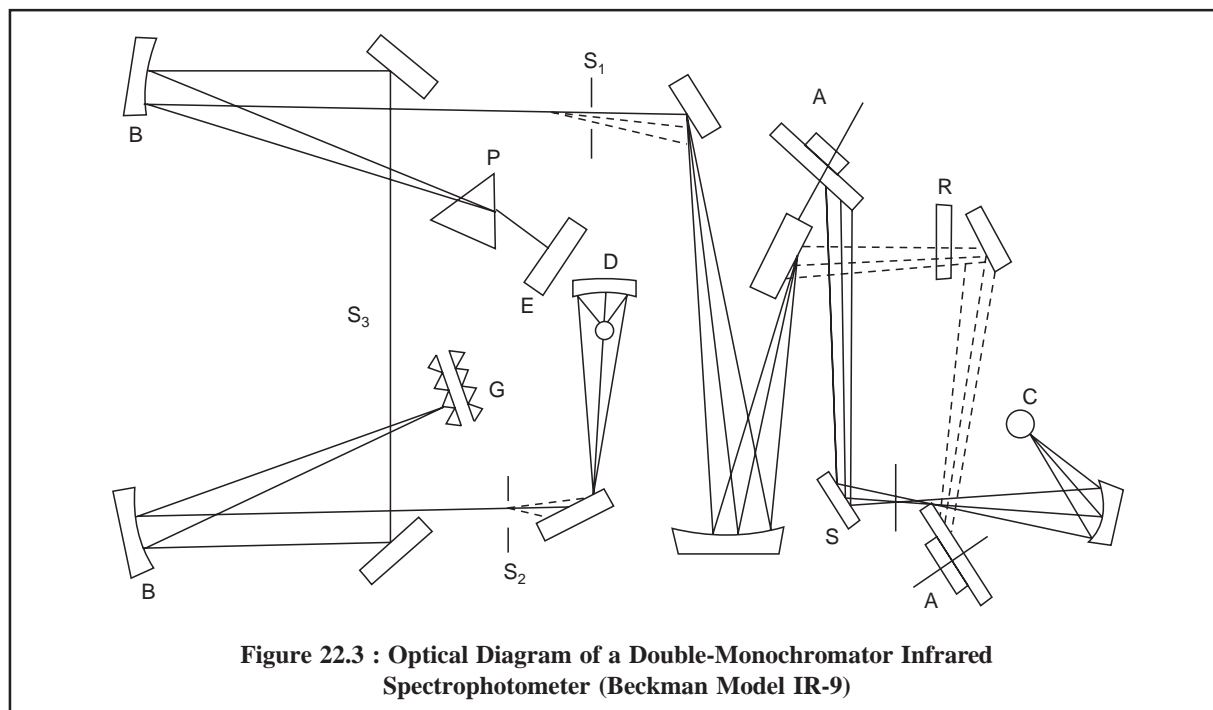

Figure 22.3 : Optical Diagram of a Double-Monochromator Infrared Spectrophotometer (Beckman Model IR-9)

The various components of a double-monochromator infrared spectrophotometer shown in Figure 22.3 are as follows below :

- A = Rotating mirror,
- B = Collimating mirror,
- C = Infrared source,
- S = Sample beam,
- R = Reference beam,
- D = Detector,
- S₁ = Entrance, slit,
- S₂ = Exit slit,
- S₃ = Intermediate slit,
- E = Littrow mirror,
- G = Monochromator Gratings, and
- P = Prism.

The various steps that may be followed sequentially to operate a double-monochromator infrared spectrophotometer are described below :

- (i) The light from the infrared source C is made to split into two beams one of which passes through the sample (*i.e.*, the sample beam) while the other caters as the reference beam. This sort of double-beam arrangement facilitates in measuring difference in intensities between the *two* beams at each wavelength,
- (ii) In this instance two monochromators have been employed in series with an intermediate slit (S₃) as shown in Figure 22.3,
- (iii) The optical train affords as much as twice the dispersion and the ultimate resolution is fairly comparable to any single-monochromator instrument (Figure 22.2),
- (iv) All stray radiant energy is virtually eliminated,
- (v) In Figure 22.3, (Beckman Model IR-9) one of the two prism monochromators has been replaced with a dual grating, and
- (vi) Finally, the detector picks up light of equal intensity from sample and reference beams.

22.3.1.5. Experimental Profile of Infrared Spectroscopy : Quantitative Analysis

In usual practice, there are *two* methods that are frequently employed for the determination of the transmittance ratio in quantitative analysis namely :

- (a) Empirical ratio method, and
- (b) Base-line method.

The above *two* methods shall be discussed briefly with the help of certain typical examples as detailed below :

22.3.1.5.1. Empirical Ratio Method

This particular method is often employed in a situation where the absorption bands of the analyte are found to be very close to those of the main constituent or the internal standard.

The quantitative analysis of pharmaceutical substances may be achieved by empirical-ratio method either by plotting percentage transmittance against wavelength or by plotting the $\log T^1_0/T^1$ against concentration as illustrated in Figure 22.4.

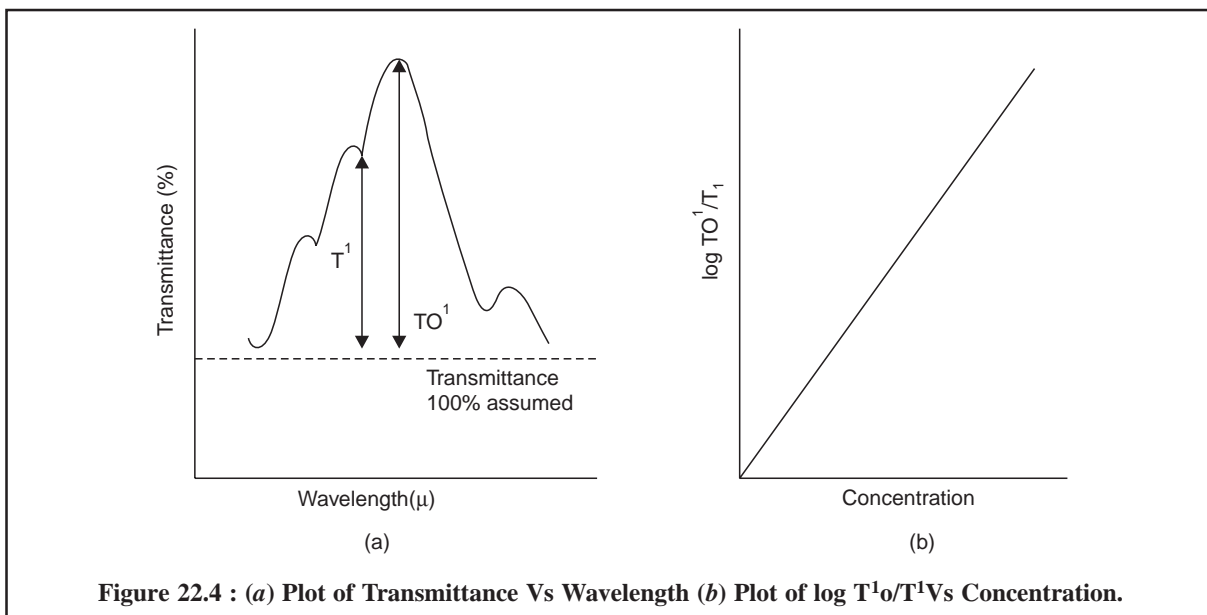

Figure 22.4 : (a) Plot of Transmittance Vs Wavelength (b) Plot of $\log T^1_o/T^1$ Vs Concentration.

22.3.1.5.2. Base-Line Method

It essentially involves the selection of an absorption band of an analyte which does not remain very close to the bands of other constituents present in the matrix.

Figure 22.5 depicts the absorption bands of the sodium salt of Penicillin G at 703 cm^{-1} .

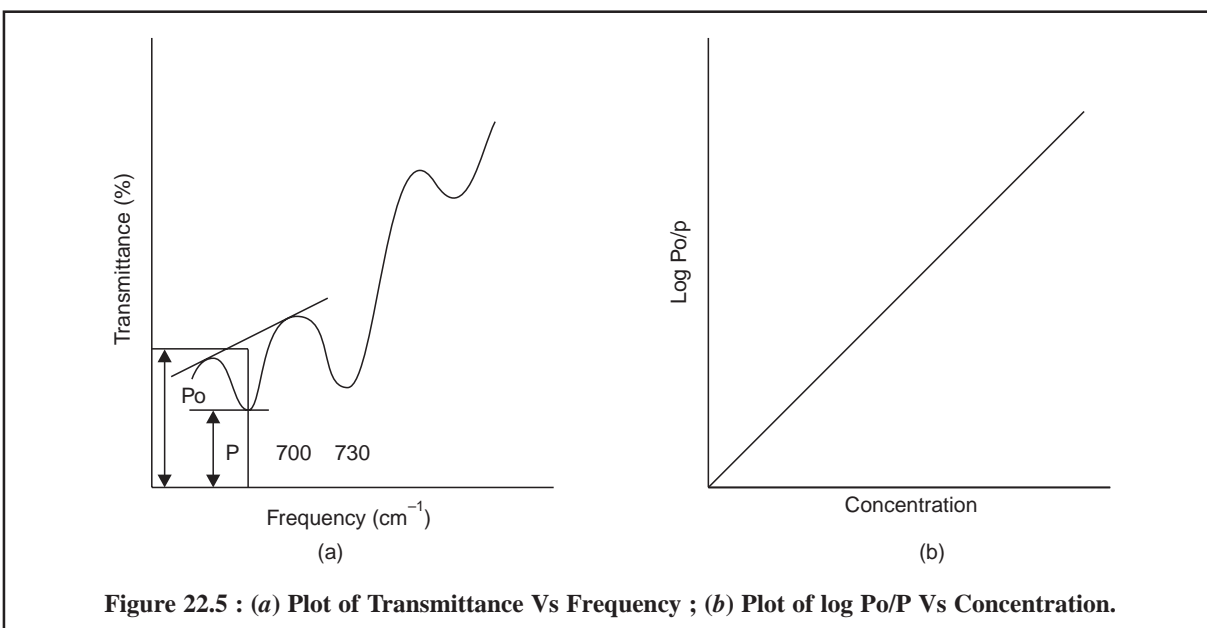

Figure 22.5 : (a) Plot of Transmittance Vs Frequency ; (b) Plot of $\log P_o/P$ Vs Concentration.

The value of the incident radiant energy P_o may be achieved by drawing a straight line tangent to the spectral absorption curve at the position of the analyte's absorption band. Consequently the transmittance P is usually measured at the point of maximum absorption. Finally, the value of $\log P_o/P$ is plotted against the concentration as shown in Figure 22.5.

It is, however, pertinent to mention here that the application of both empirical ratio method and base-line method help in eliminating to a great extent the errors caused due to changes in source intensity and adjustment of the optical system.

22.3.1.6. Determination of the Absorption Spectrum of a Solid Compound (or a Pharmaceutical Substance)

The determination of the absorption spectrum of a solid pharmaceutical substance is invariably accomplished by any one of the *two* following techniques namely :

- (a) Mull Technique, and
- (b) Potassium Bromide Disc Technique.

These *two* different techniques shall be described below :

22.3.1.6.1. Mull Technique

Procedure : Take about 15-20 mg of sample in a previously cleaned small agate mortar and powder it thoroughly (about 200 mesh). Add to it 2 drops of purified paraffin (commonly known as Nujol) or any other suitable mulling liquid and continue the trituration until a very smooth paste of uniform consistency is achieved. Now, transfer the slurry to a sodium chloride window, placing it carefully into the cavity made by the spacer. Consequently, place the other window on top and thus assemble the cell. With the help of a clean piece of tissue-paper wipe out the excess paste that has squeezed out from the cell windows. Finally, introduce the cell in the respective cell-compartment.

Salient Features : The salient features of Mull Technique are as follows :

- (i) Particle size of the sample has got to be reduced below 200 mesh or $3\ \mu\text{m}$ so as to avoid scattering of radiation thereby causing poor absorption spectrum.
- (ii) Hydrogen bonding and crystal forces usually influence the trace obtained.
- (iii) Paraffin itself gives rise to strong band either at $1460\text{-}1380\ \text{cm}^{-1}$ or at $2820\text{-}2850\ \text{cm}^{-1}$.

22.3.1.6.2. Potassium Bromide Disc Technique

Procedure : For a window of diameter 1.3 cm, take 100 mg of spectroscopic grade KBr in a previously cleaned agate pestle and mortar and grind it thoroughly with 0.05-0.5 mg of the sample. Now, carefully place the sample mixture into the pressing chamber of the mould in such a manner that it is held between the polished surfaces of the bottom and top pressing dies. Subsequently, attach the chamber to the vacuum line and switch-on the vacuum pump ; initially applying a slight negative pressure so as to compact the powder and then gradually increasing it to $\leq 15\ \text{mm Hg}$ for 30 seconds. Finally, enhance the pressing force to $100,000\ \text{lb/in}^2$ or $10\text{-}12\ \text{tons/in}^2$ for a period of 1-2 minutes. Carefully, release the pressure and dismantle the dies. Now, remove the window from the mould and keep it in position onto the sample holder.

Salient Features : The salient features of KBr-disc technique are stated below :

- (i) There exists a possibility of interaction between vibrations of the sample and the potassium halide lattice,
- (ii) It is considered to be the most suitable method for other screening of very minute quantities of substances being eluted from the columns in Gas Liquid Chromatography (GLC). In actual practice, about 300 mg of the spectroscopic grade KBr is placed in a short column immediately after the detector. Consequently, the solid is powdered, pressed into a disc in the normal procedure and ultimately the absorption spectrum of the trapped substance is studied,
- (iii) It enjoys the advantage of producing spectra absolutely free from any solvent peaks (unlike Mull Technique) and hence it is employed extensively in routine analysis.

Internal Standard for KBr-Disc Technique : In quantitative analysis it is essential to examine absolutely uniform discs of identical weights. To achieve this, known weights of both KBr and analyte are required in the preparation of the KBr-disc and finally from the absorption data a calibration-curve may be obtained. In this process, it is a must to weigh the discs and also to measure their thickness at different points

on their surface with the help of a dual micrometer. In order to overcome this tedious process of measuring disc thickness carefully the use of an internal standard has been introduced.

Potassium thiocyanate (KSCN) is considered to be the **choicest internal standard**. In usual practice, it must be preground, dried and subsequently reground, and used at a concentration of 0.2% (w/w) along with the dried spectroscopic grade KBr. The mixture of KBr-KSCN is stored over P_2O_5 .

Procedure : A standard calibration curve is plotted by thoroughly mixing together about 10% (w/w) of the analyte with the KBr-KSCN mixture and then grinding the same intimately. Now, the ratio of the thiocyanate absorption at 2125 cm^{-1} to a selected band absorption of the analyte is plotted against the percent concentration of the sample. Likewise, an identical disc is prepared with the unknown sample and the same KBr-KSCN mixture. Finally, its absorbance ratio is determined and the concentration (of unknown sample) is read off directly from the standard calibration curve.

22.3.1.7. Calibration of Infrared Spectrophotometers

The wavelength (or wave number) scale calibration of infrared spectrophotometers is usually carried out with the aid of a strip of polystyrene film fixed on a frame. It consists of several sharp absorption bands, the wavelengths of which are known accurately and precisely. Basically, all IR-spectrophotometers need to be calibrated periodically as per the specific instructions so as to ascertain their accuracy and precision.

22.4. APPLICATIONS OF IR-SPECTROSCOPY IN PHARMACEUTICAL ASSAYS

22.4.1. APPLICATIONS OF IR-SPECTROSCOPY IN THE ANALYSIS OF PHARMACEUTICAL SUBSTANCES

A host of pharmaceutical substances can be identified and critically examined with the help of infrared spectroscopy. Hence, the latest versions of British Pharmacopoeia (BP) and United States Pharmacopoeia (USP) contain the complete IR-spectrum of such pure pharmaceutical substances that are essentially included in the respective *official compendium*. These authentic IR-spectra are profusely used in many well-equipped Quality Assurance Laboratories in checking the purity of commercially available drugs before employing them in various formulations.

Following is the detailed procedure laid out in the Pharmacopoeia of India (IP) for the preparation of KBr-disc or KCl-disc :

Procedure : Triturate about 1 mg of the pharmaceutical substance with approximately 300 mg of dry, finely powdered KBr or KCl of spectroscopic grade, as directed. Grind the mixture thoroughly, spread it uniformly in a suitable die and compress under vacuum at a pressure of about 10 t in^{-2} . Mount the resultant disc in a suitable holder in the spectrophotometer and obtain the IR-spectrum.

Precautions : The following precautions may be observed carefully :

- (i) Several factors *e.g.* excessive or insufficient grinding, absorption of moisture or other impurities in the halide carrier, may ultimately result in the formation of unsatisfactory discs,
- (ii) Unless its preparation presents certain specific difficulties a disc should be rejected if visual inspection shows lack of uniformity, or if the transmittance at about 2000 cm^{-1} ($5\text{ }\mu\text{m}$) in the absence of a specific absorption band is less than 75% without compensation, and
- (iii) If the other ingredients of tablets, injections or other dosage forms are not completely removed from the substance being examined, they may contribute to the spectrum.

Example : The infrared absorption spectrum of the following pharmaceutical substances do exhibit maxima which are only at the same wavelengths as, and have similar relative intensities to those in the spectrum of the corresponding reference samples, namely :

Ampicillin sodium ; Amylobarbitone ; Betamethasone ; Betamethasone valerate ; Carbenicillin disodium ; Chloroquine phosphate ; Chloroquine sulphate ; Cimetidine ; Clofazimine ; Clofibrate ; Clonidine

hydrochloride ; Cloxacilline sodium ; Colchicine Cyclophosphamide ; Cyproheptadine hydrochloride ; Dexamethasone ; Activated dimethicone ; Diphenylpyraline hydrochloride ; Erythromycin estolate ; Ethambutol hydrochloride ; Ethirylestradiol ; Ethiosuximide ; Fludrocortisone acetate ; Fluphenazine hydrochloride ; Iburprofen ; Diluted isosorbide dinitrate ; Lincomycin hydrochloride ; Mebendazole ; Metoformin hydrochloride ; Methdilazine hydrochloride ; Methotrexate ; Nalidixic acid ; Nandrolone decanoate ; Nandrolone phenylpropionate ; Niclosamide ; Nitrofurantoin ; Nitrofurazone ; Norethisterone ; Oxprenolol hydrochloride ; Pentazocine hydrochloride ; Pentolamine hydrochloride ; Phentolamine mesylate ; Primidone ; Prochlorperazine mesylate ; Proguanil hydrochloride ; Pyrazinamide ; Pyrimethamine ; Rifampicin ; Spironolactone ; Stilbosterol diphosphate ; Sulphadimethoxine ; Sulphalene ; Sulphamethizole ; Testosterone propionate ; Thiabendazole ; Trifluoperazine hydrochloride ; Triflupromazine hydrochloride.

22.4.2. APPLICATIONS OF IR-SPECTROSCOPY IN THE ANALYSIS OF PHARMACEUTICAL DOSAGE FORMS

A number of pharmaceutical dosage forms can be assayed conveniently with the help of IR-spectroscopy. A few typical examples are enumerated below for ready reference, namely :

22.4.2.1. Determination of Aspirin, Phenacetin and Caffeine in Tablets

Theory : The quantitation is solely based on the intensities of the carbonyl bands at 1764, 1511 and 1665 cm^{-1} for aspirin, phenacetin and caffeine respectively.

Materials Required : APC-Tablets ; Chloroform ;

Procedure : The drug contents of an appropriate number of tablets are directly extracted into chloroform, filtered if necessary so as to remove the insoluble tablet components, and the final concentration of chloroform solution is made in such a way so that it should contain : 90 mg ml^{-1} of aspirin ; 64 mg ml^{-1} of phenacetin, and 134 mg ml^{-1} of caffeine. The IR-spectrum is now recorded in a 0.1 mm NaCl-cell between 1400-2000 cm^{-1} .

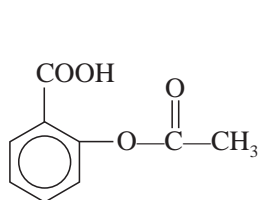

Aspirin

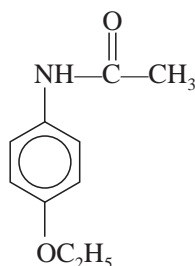

Phenacetin

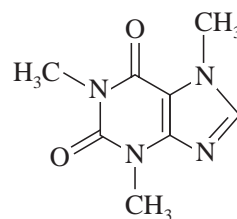

Caffeine

22.4.2.2. Determination of Codeine Phosphate in Tablets

Codeine phosphate was duly extracted into CS_2 and quantitatively determined by measuring its absorption at 942 cm^{-1} .

22.4.2.3. Determination of Meprobamate in Tablets

Maynard (1960) carried out the analysis of meprobamate by dissolving it in chloroform (spectroscopic grade) and subsequently determining the intensity of the amide carbonyl band ($\text{—}\overset{\text{O}}{\parallel}{\text{C}}\text{—}$) at 1582 cm^{-1} . Later Shearken (1968) adopted a modified method of assay by using chloroform as an extracting medium, but instead of the carbonyl band measured the N—H stretching band at 3436 cm^{-1} . However, this particular method essentially requires the complete removal of both water and ethanol ; the latter is present in CHCl_3 as a stabilizer which is required to be eliminated completely to avoid interference from O—H stretching bands. To achieve this objective activated alumina columns have been used extensively. However, Zappala and Post

(1977) got rid of the interferences occurring at lower frequencies by measuring meprobamates by employing the primary amine combination band at 5107 cm^{-1} in the near IR region.

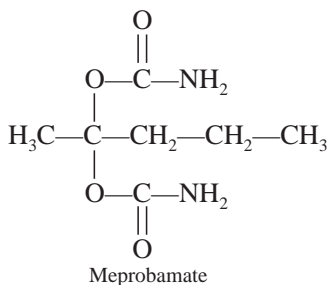

22.4.2.4. Cognate Assays

The USP (XIX) and NF (XIV) have described the assays of various pharmaceutical dosage forms in appropriate solvent at different frequencies (cm^{-1}). A few typical examples are given in Table 22.2.

Table 22.2 : Quantitative IR Analysis Profile of some Dosage Forms as per USP* and NF**

S. No.	Pharmaceutical Substance/Preparation	Chemical Structure	Solvent used	Frequency (cm^{-1})
1.	Cyclizine Lactate Inj.		Cyclohexane	704
2.	Cyclophosphamide Injection/Tablets		KBr Pellet with $\text{Fe}(\text{SCN})_3$ Internal Standard	1053
3.	Iodochlorhydroxyquin Cream/Ointment		Carbon Sulphide	694
4.	Methocarbamol Inj./Tablets		Chloroform	1730
5.	Quinethazone Tablets		Cyclohexane	1342

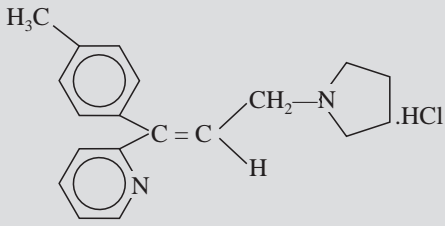
6.	Simethicone Tablets/ Suspension	$(\text{CH}_3)_3\text{SiO}[(\text{CH}_2)_2\text{SiO}]_n\text{Si}(\text{CH}_3)_3$	Carbon Tetrachloride	1269
7.	Triprolidine Hydrochloride		Cyclohexane	824

*USP (XIX) ; ** N.F. (XIV) ;

22.5. APPLICATIONS OF IR-SPECTROSCOPY IN ANALYTICAL CHEMISTRY

The technique of infrared spectroscopy has been adequately exploited in the domain of analytical chemistry. This aspect is duly expatiated with the aid of the following typical examples, namely :

22.5.1. DETERMINATION OF *CIS-TRANS* ISOMER RATIO IN CLOMIPHENE CITRATE

It is a gonad stimulating principle.

Theory : It is an established fact that *cis*- and *trans*-substituted double bonds have slightly different absorption bands in the region of 13 μm . This specific feature forms the basis of the present determination.

Besides, the pharmacological actions of many compounds are invariably dependent on the shape of molecules and hence, usually play a very significant role. Therefore, if both *cis*- and *trans*-isomers are produced in the course of a particular synthesis it may be absolutely necessary to incorporate in the product profile a specific test for the relative proportions of one to the other. This type of 'control measure' strictly conforms the uniformity of composition in the bulk-drug industry and ensures a check on the batch-to-batch variation.

Procedure : Dissolve accurately 22.5 mg of *trans*-clomiphene citrate and 52.5 mg of *cis*-clomiphene citrate (approx. 1 : 2.3) into 10 ml of DW in a clean 50 ml separating funnel. Add to it 1 ml solution of sodium hydroxide (5% w/v in DW). In the alkaline medium the base is liberated which is extracted successively with 3 portions of solvent ether (10 ml each). The combined ethereal layer is washed with two portions of DW (10 ml each). The resulting ethereal fraction is dried over anhydrous sodium sulphate, filter, evaporate to dryness carefully over an electric water-bath and dissolve the residue in 1 ml of CS_2 . Now, record the absorption curve in a 0.2 mm cell over the range 12.50 to 14.00 μm . Calculate the absorbance for the peaks at 13.16 and 13.51 μm respectively by employing the base-line method (see section 3.1.B in this chapter) between the minima at 12.66 and 13.89 μm .

Finally, repeat the assay with a 1 : 1 mixture (75 mg) of *cis* and *trans*-clomiphene citrates and also with clomiphene citrate (75 mg) as such. Thus, calculate the ratio as follows :

$$\frac{\text{Absorbance at } 13.16 \mu\text{m}}{\text{Absorbance at } 13.51 \mu\text{m}}$$

with regard to each assay and therefrom confirm at the ratios of the sample falls very much within the ratios for the standards thereby indicating that the sample contains 50-70% *cis*-clomiphene citrate.

22.5.2. TO DISTINGUISH AND CHARACTERIZE THE PRI-, SEC-AND TERT-AMINE SALTS FROM ONE ANOTHER

Example : (+) Amphetamine Sulphate-a pri-amine salt, χ -Ephedrine Sulphate-a sec-amine salt, and Quinine Hydrochloride-a tert-amine salt.

22.5.3. IR-SPECTROSCOPY IN THE STUDY OF COMPLEX FORMATIONS

The IR-spectroscopy has been judiciously used for the study of complex formations.

Examples :



acids under appropriate conditions to result in the formation of a *deep blue complex*. This reaction is so sensitive that it forms the basis of quantitative complex formation studies by IR-spectroscopy.

(b) **1 : 10-Phenanthrolin** : reacts with Fe^{2+} ion quantitatively to give rise to a deep red complex due to formation of phenanthroline-ferrous complex, which being extremely sensitive in nature is usually exploited as the basis of quantitative complex formation studies by IR-spectroscopy.

22.5.4. IR-SPECTROSCOPY IN QUANTITATIVE REACTION SEQUENCE STUDY

IR-spectroscopy technique has been used meaningfully in the qualitative reaction sequence studies with regard to various organic synthesis, namely : reduction of —NO_2 group to —NH_2 ; reduction of $\text{—}\overset{\text{O}}{\parallel}{\text{C}}\text{—}$ carbonyl group to —CH (OH) ; oxidation of methyl-group to —COOH ; etc.

22.5.5. IR-SPECTROSCOPY IN THE IDENTIFICATION OF FUNCTIONAL GROUPS

A few salient features in this context are, namely :

- (a) The absence of a specific characteristic absorption may be more informative than its presence, e.g., the presence *vis-a-vis* absence of a $\text{C} = \text{O}$ str. absorption.
- (b) Multifunctional compounds invariably exhibit altogether separate absorption peaks due to the presence of individual functional groups. In a situation where these functional groups interact with each other either absorption peaks merge with one another or they shift from their original positions, for instance :

Glycine : $\text{H}_2\text{N—CH}_2\text{—COOH}$ (α -amino acetic acid i.e., and aliphatic amino acid) ;

Pentane-2, 4-dione, acetylacetone : $\text{CH}_3\text{CO CH}_2 \text{COCH}_3$ - $\alpha\beta$ -diketone ;

para-Hydroxybenzoic acid : $\text{HO—C}_6\text{H}_4\text{—COOH}$ - $\alpha\gamma$ -hydroxy acid (aromatic) ;

- (c) Graphically presented correlation tables, as cited in specialist texts of Cross, Bellamy and Van der Mass, are found to be fairly precise and accurate for the critical identification of functional groups. It is, however, pertinent to mention here that the degree of accuracy lies between $\pm 5 \text{ cm}^{-1}$ for ordinary routine IR-spectrophotometers having lesser observed accuracy at higher frequencies.
- (d) Keeping in view the vast wealth of expertise and experience, it may be inferred that the maximum weightage can be solely rested on the absorptions either below 900 cm^{-1} , or above 1400 cm^{-1} , for obvious reasons as the 'fingerprint region' $900\text{-}1400 \text{ cm}^{-1}$ mainly contains a plethora of unassigned absorptions.
- (e) Group frequencies are invariably more readily accountable and hence valuable in comparison to the corresponding single absorption bands. It may be further expatiated due to the fact that a functional group which often results in many specific and characteristic absorption bands can be identified more precisely and definitely than a function which produces only one characteristic absorption band. For instance :

(i) **Esters** ($\begin{array}{c} \text{O} \\ || \\ \text{---C---OR} \end{array}$) : It affords group frequencies due to C = O str., and C—O str. and hence more readily identified than the ketones (C = O str.)

(ii) **Amides** ($\begin{array}{c} \text{O} \\ || \\ \text{---C---NH.H} \end{array}$) : It gives rise to group frequencies on account of (C = O str., N—H str., N—H def.) and, therefore, more easily identified than the corresponding amides.

22.5.6. IR-SPECTROSCOPY : IDENTIFICATION BY FINGERPRINTING

The 'fingerprint region' lies between 1300-400 cm^{-1} which is considered to be the most valuable component of the spectra and mainly comprises of a specifically large number of unassigned vibrations. Therefore, IR-spectroscopy aids in the identification of unknown compound by comparing its spectrum with a standard spectra recorded under exactly similar experimental parameters. Thus, pharmaceutical substances that exhibit the same infrared spectra may be inferred as identical.

Precisely in the domain of analysis by physico chemical property IR-spectroscopy offers a far more characteristic, valid and qualified '**proof of identity**' than the comparison of any other physical property.

Precautions : Certain precautions may be observed readily so as to obtain really identical spectra, namely :

- (a) Sampling to be done under identical conditions,
- (b) Same IR-spectrophotometer may be used for obtaining the various spectra,
- (c) Experimental parameters like : slit-width, scan-speed etc., must be identical,
- (d) An attempt should be made to obtain the maximum number of peaks in the '*fingerprint region*' thereby ascertaining the **proof of identity** more confidently.

Computer Aided Analysis : With the advent of spectacular and quantum jump in the field of instrument technology over the past two decades a good number of world-renowned manufacturers, such as : Beckman, Bio-Rad, Brüker, Cecil, Hitachi, Nicolet, Perkin-Elmer, Schumadzu have introduced various sophisticated fully computerized FT-IR spectrophotometers. These instruments have the advantage of storing in their computer-memory-banks of sizable number of digitalized information obtained from the infrared spectra of standard compounds. Now, with the flick of a keyboard button the spectrum of an unknown compound, previously fed to the same digital storage bank, may be conveniently compared with the standards and finally to get at the identical infrared absorptions to the unknown.

22.5.7. INTERPRETATION OF AN IR-SPECTRUM

There exist no hard and fast rules with regard to the interpretation of an IR-spectrum, but based on the vast wealth of experience and wisdom of the analyst amalgamated with a storehouse of general observations go a long way towards the exact interpretation of the same. However, following different aspects must be taken into consideration while interpreting the spectrum :

- (a) In usual practice, the absence of a strong group absorption definitely indicates the absence of that group in the molecule, based on the assumption that no other factors are influencing which might shift the absorption band to the other regions *e.g.*, hydrogen bonding. In other words, intramolecular or intermolecular changes caused due to the hydrogen bonding help in shifting the expected absorption band either to the higher region or to the lower region. For instance : the clear absence of a sharp and strong absorption band in the region 1850-1640 cm^{-1} (or 5.40-650 μ) completely excludes the possibility of carbonyl groups from the molecular structure under investigation.

(b) It is quite important to carry out all the preliminary examination of the IR-spectrum of an unknown compound exclusively and definitely on the regions above $900\text{-}650\text{ cm}^{-1}$ ($11.1\text{-}15.4\text{ }\mu$) and above 1350 cm^{-1} (below $7.40\text{ }\mu$). For example :

Free NH_2 and free NH	: $3300\text{-}3500\text{ cm}^{-1}$
Bonded NH	: $3100\text{-}3400\text{ cm}^{-1}$
= NH	: $3300\text{-}3400\text{ cm}^{-1}$
Free OH	: $3550\text{-}3650\text{ cm}^{-1}$
Intermolecular Bonded OH	: Dimeric — $3450\text{-}3550\text{ cm}^{-1}$
	Polymeric — $3200\text{-}3400\text{ cm}^{-1}$
Intramolecular Bonded OH	: $3420\text{-}3600\text{ cm}^{-1}$

(c) **‘Fingerprint Region’** *i.e.*, the intervening region $1300\text{-}400\text{ cm}^{-1}$ essentially provides very useful information, specifically when examined with reference to bands in the lower and higher regions. It frequently consists of a relatively large number of bands the origin of which is neither located nor determined so easily. Broadly speaking, the ‘fingerprint region’ helps in the identification of unknown pharmaceutical substances with the aid of reference samples and comparing the two spectra by superimposing them on one another. For this reason many *official compendia* like BP, USP provide the spectra of many pure and authentic pharmaceutical substances that may be compared with the ones under investigation.

(d) **Assignment of Bands to Specific Groups by Employing Isotopes** : Deuterium exchange is specifically beneficial for assignment to A-H vibrations in a situation where the hydrogen is exchangeable.

For a simple diatomic molecule X-Y the sole vibration which may take place in a periodic stretching along the X-Y band. Thus, the stretching vibrations may be visualized as the oscillations of two entities connected by a spring and the same mathematical treatment, known as **Hooke’s Law**, holds good to a first approximation. Hence, for stretching of the band X-Y, the vibrational frequency (cm^{-1}) may be expressed by the following equation :

$$\bar{\nu} = 1302 \sqrt{k/\mu} \quad \dots(a)$$

where, k = Force constant, and

μ = Reduced mass of the two atoms.

Therefore, for bands having the same force constant k :

$$\bar{\nu} \propto \mu^{-1/2} \quad \dots(b)$$

Thus, it may be shown that the absorption frequencies for a bond involving deuterium are, to a rough approximation $1/\sqrt{2}$ times the frequencies of the corresponding bonds involving hydrogen.

Examples :

(i) Free OH shows absorption at $3550\text{-}3650\text{ cm}^{-1}$; whereas OD shows absorption at $2400\text{-}2800\text{ cm}^{-1}$;

(ii) Free NH shows absorption at $3300\text{-}3500\text{ cm}^{-1}$; whereas free ND shows absorption at $2400\text{-}2600\text{ cm}^{-1}$.

In addition to the above cited typical instances the hydrogen bonding can also be studied at length by subsequent replacement of proton by deuterium.

(e) **Assignment of Bands to Specific Groups by Affecting Chemical Changes** : Various chemical changes brought about in the organic compounds may be assigned different absorption peaks on the specific modified chemical entities. This can be explained with the help of the (see next page) examples, namely :

(i) Conversion of an acid to its corresponding salt, or an ester or a primary amide :

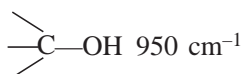
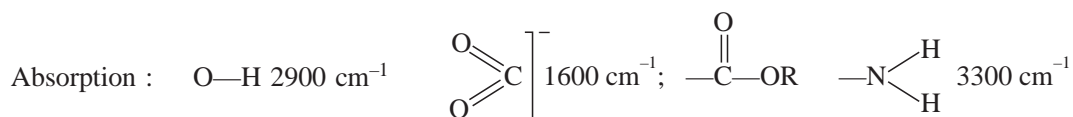
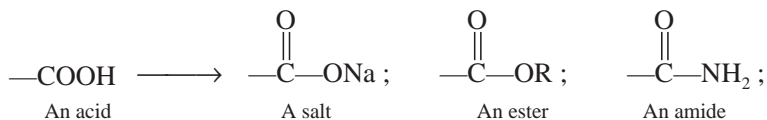

(ii) Conversion of an Amino Acid to its corresponding hydrochloride or salt :

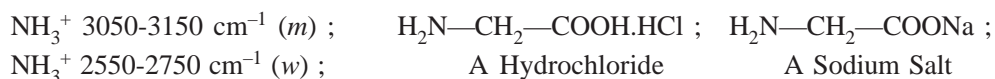
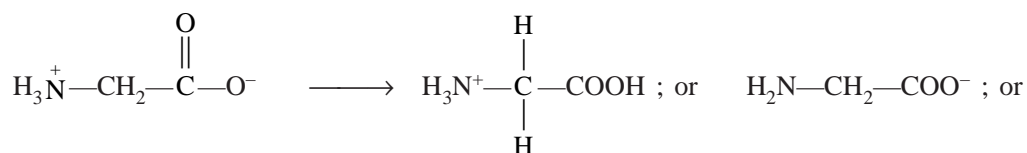

THEORETICAL AND PRACTICAL EXERCISES

- Explain the following 'terminologies' explicitly in IR-Spectrophotometry :
 - Group frequency region,
 - Fingerprint region,
 - Molecular vibrations,
 - Vibrational coupling,
 - Hydrogen Bonding (in IR),
 - Electronic effects, and
 - Field effects.
- IR-Spectrophotometer variants are of two types :
 - Single monochromation, and
 - Double monochromation.

Describe any ONE of them with a neat-labeled optical diagram and its *modus operandi*.
- Discuss the experimental profile of IR-Spectroscopy with regard to :
 - Empirical ratio method, and
 - Base-line method.
- What are the two commonly used techniques invariably employed for the determination of 'absorption spectrum' of a solid 'drug'. Explain.

5. How do we assay the following dosage forms by IR-spectroscopy ? Explain.
- (i) Meprobamate Tablets, (ii) Cyclizine lactate Injection,
(iii) Cyclophosphamide Tablets, (iv) Methocarbamol Injection,
(v) Simethicone Tablets, and (vi) Tripolidiue hydrochloride.
6. Explain IR-spectroscopy in 'analytical chemistry' for the determination of :
- (a) *cis-trans* Isomer ratio in clomiphene citrate.
(b) Differentiation of *pri-sec*- and *tert*-Amine salts.
(c) Quantitation reaction sequence studies.
(d) Complex formations.
(e) Identification of functional groups.
7. Give a comprehensive account on the interpretation of an IR-Spectrum. Explain.

RECOMMENDED READINGS

1. Parke, TV, AM Ribley, EE Kennedy and WW. Hilty, **Anal Chem.** **33**, 953, 1953.
2. Matnard, WR Jr., **J. Assoc. Off. Agric. Chem.**, **43**, 791, 1960.
3. Sharken, S., **J. Assoc. Off Anal. Chem.**, **51**, 616, 1968.
4. Miller, RGJ and BC Stace, '**Laboratory Methods in Infrared Spectroscopy**', 2nd ed., London, Hyden, 1972.
5. Zappala, AF and A. Post., **J. Pharm. Sci**, **66**, 292, 977.
6. Nakanishi, K., '**Infrared Absorption Spectroscopy**', 2nd ed., San Fransisco, Holden-Day, 1997.
7. Meehan, EJ, '**Spectroscopic Apparatus and Measurements**', In **Treatise on Analytical Chemistry**, ed by PJ Elving, EJ Meehan, Ed. I.M. Kolthoff, Ed., Vol. 7., New York, John Wiley and Sons Inc., 1981.
8. Perkins, WD, '**Fourier Transform-Infrared Spectroscopy**', **J. Chem. Educ.** **63**, A 5, 1986.
9. Griffiths, RS and JA de Haseth, '**Fourier Transfer Infrared Spectroscopy**', New York, Wiley, 1986.

23 NUCLEAR MAGNETIC RESONANCE SPECTROSCOPY

CONTAINS :

- 23.1 Introduction
 - 23.1.1 The NMR-phenomenon
 - 23.1.2 Information provided by $^1\text{H-NMR}$ (Proton-NMR)
- 23.2 Theory
 - 23.2.1 Orientations of magnetic nucleus under B_0
 - 23.2.2 Precessional frequency (ν)
 - 23.2.3 Saturation of the signal
 - 23.2.4 Absorption positions in NMR-spectrum
 - 23.2.5 Chemical shift
 - 23.2.6 Spin-spin interactions
 - 23.2.7 $^3\text{H-NMR}$ (Tritium NMR-spectroscopy)
 - 23.2.8 $^{13}\text{C-NMR}$ -spectroscopy
 - 23.2.9 2D-NMR (Two dimensional correlational spectroscopy or two dimensional cosy spectrum)
- 23.3 Interpretation of a NMR-spectrum
 - 23.3.1 Chemical shift (δ) (relative to reference compound usually Me_4Si)
 - 23.3.2 Relative peak area
 - 23.3.3 Multiplicity of the signal
 - 23.3.4 Coupling constant
- 23.4 Instrumentation
- 23.5 Applications of NMR-spectroscopy in pharmaceutical analysis
 - 23.5.1 Identification testing
 - 23.5.2 Assay of drugs

23.1. INTRODUCTION

Nuclear Magnetic Resonance (NMR) spectroscopy just like IR and UV is regarded as a process whereby energy from an external source is absorbed and brings about a change or resonance to an 'excited' or high energy state. The energy required for NMR lies in the low energy or long wavelength radio-frequency end of the electromagnetic spectrum.

Consequent to the magnetic properties of nuclei arising from the axial spin, the emerging radio-frequency gets absorbed in a magnetic field. Therefore, for a particular nucleus an NMR absorption spectrum invariably comprises one to several groups of absorption lines in the radio-frequency portion of the electromagnetic spectrum. Evidently, the location of peaks indicate the chemical nature of the nucleus, whereas the multiplets provide information regarding the spatial positions of the neighbouring nuclei. Hence, NMR is also known as **Nuclear Spin Resonance (NSR)** spectroscopy.

NMR has accomplished a growth in a geometrical progression since the early sixties and virtually developed into extremely potential analytical tools not only useful for elucidation of complex structural determinations but also equally beneficial in the assay of pharmaceutical substances.

In reality, NMR spectroscopy has broadened the scope and absolute possibility for performing more extensive as well as intensive studies with regard to recording the spectrum of isolated and synthesized organic molecules in addition to their mechanistic and stereochemical details hitherto inaccessible. Therefore, NMR spectroscopy finds its applications for compound identification, by means of a **'fingerprint technique'** very much identical to that used in *IR-spectroscopy*. Besides, it is invariably utilized as a specific method of assay for the individual constituents of a mixture. A few typical examples of drug assays will be dealt separately at the end of this chapter to justify its efficacy and usefulness.

23.1.1. THE NMR PHENOMENON

Following are the *five* different aspects that essentially govern the NMR phenomenon, namely :

A. The Spinning Nucleus : The nucleus of the hydrogen atom, *i.e.*, the proton, just behaves as if it is a small spinning bar magnet. It does so because it evidently possesses an electrical charge as well as a mechanical spin. Consequently, a spinning charged body will generate a magnetic field, and hence the nucleus of hydrogen atom is not an exception.

B. The effect of an External Magnetic Field : As a **'compass needle'** possesses an inherent tendency to align itself with the earth's magnetic field, the proton not only responds to the influence of an external magnetic field but also tends to align itself with that field. However, because of restrictions as applicable to nuclei (not to compass needles) the proton can only adopt the following two orientations with regard to an external magnetic field. At this juncture *two* situations normally arise, namely :

- (a) when proton is aligned with the field (*i.e.*, at lower energy state), and
- (b) when proton is opposed to the field (*i.e.*, at higher energy state).

Some NMR-analysts describe these proton orientations as **'parallel'** with or **'antiparallel'** with the applied field.

C. The Precessional Motion : The proton appears to be behaving as **'spinning magnet'** and therefore, not only can it align itself with or oppose an external field, but also may move in a characteristic manner under the influence of the external magnet.

Figure 23.1, represents the precessing nuclei *vis-a-vis* the transition energy (ΔE) of reorientation of magnetic dipole between the aligned and opposed conditions when subjected to an external magnetic field (B_0). It is absolutely clear from this Figure that the proton gets aligned with the external magnetic field only at a lower energy states, while it becomes opposed to the field at higher energy states.

However, the energy of the reorientation of magnetic dipole, ΔE , may be expressed as follows :

$$\Delta E = h\nu$$

where, h = Planck's constant, and

ν = Frequency of radiation.

In order to understand the precessional motion more vividly, let us take the example of a spinning 'top' and its spinning motion. The top will (unless absolutely vertical) also perform a comparatively slower *waltz-like motion* whereby the spinning axis of the top moves slowly around the vertical. This particular phenomenon is known as the **precessional motion** and hence, the 'top' is generally said to be precessing around the vertical axis of the earth's gravitational field. In other words, the precession comes into effect due to the interaction of spin (*i.e.*, *gyroscopic motion*) with the earth's gravity vertically downwards. Therefore, a spinning top will precess, whereas a static top will fall over (not precess).

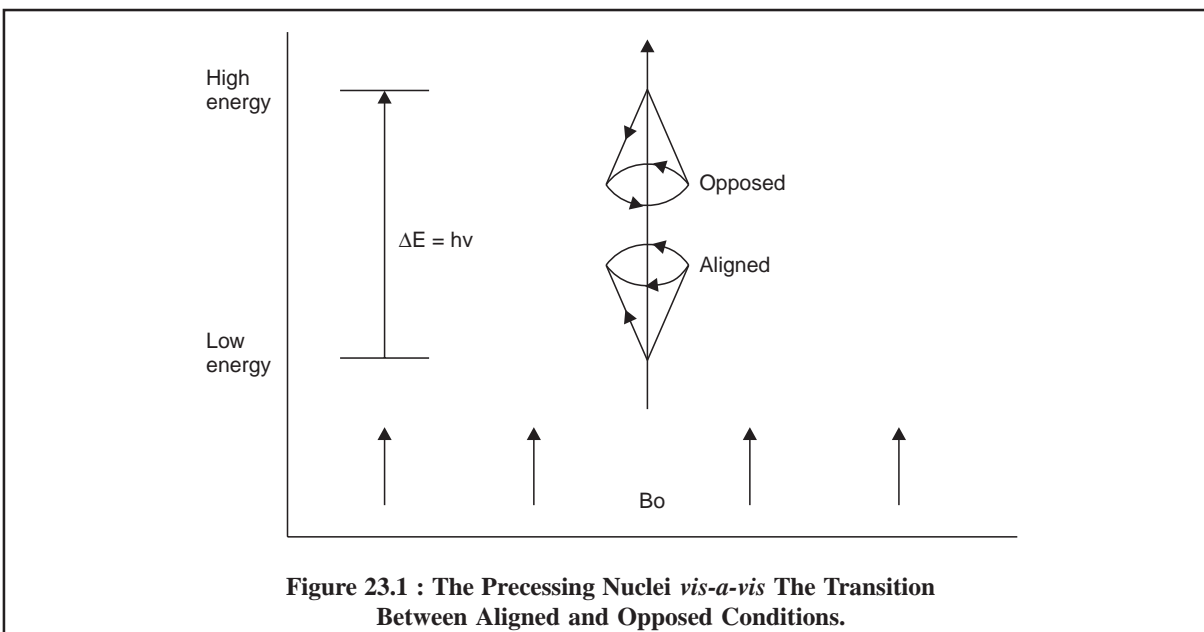

Figure 23.1 : The Precessing Nuclei *vis-a-vis* The Transition Between Aligned and Opposed Conditions.

D. The Precessional Frequency : The spinning frequency of the nucleus does not change at all, whereas the speed of precession does. Therefore, $\nu \propto B_0$, *i.e.*, the precessional frequency is directly proportional to the strength of the external field B_0 .

It designates one of the most important relationships in NMR-spectroscopy.

Example : A proton exposed to an external magnetic force of 1.4 T (\equiv 14, 000 gauss) will precess \approx 60 million times per second so that the precessional frequency $\nu = 60$ MHz ; and for an external field of 2.3 T, $\nu \approx 100$ MHz, and at 5.1 T, $\nu \approx 200$ MHz.

E. The Energy Transitions : Whenever a proton is precessing in the aligned orientation (low energy) it can absorb energy and pass into the orientation (high energy) ; and subsequently it can lose this extra energy and relax back into the aligned state.

Interestingly, the precessing proton can only absorb energy from the radio frequency source if the precessing frequency is exactly the same as that of the radio frequency beam ; and when this particular situation arises, the nucleus and the radio frequency beam are said to be in resonance, thereby justifying the term 'nuclear magnetic resonance'.

In NMR spectroscopy, the precessing protons of an organic molecule, after being duly exposed to a powerful external magnetic field (ranging between 60-400 MHz), are irradiated with radio frequency energy of the appropriate frequencies, thereby promoting protons from the low-energy (aligned state) to the high-energy (opposed state). The absorption of energy is ultimately recorded in the form of NMR spectrum as shown in Figure 23.2.

23.1.2. INFORMATIONS PROVIDED BY $^1\text{H-NMR}$ (PROTON-NMR)

$^1\text{H-NMR}$ provides a number of valuable informations stated below, which are employed for the structural elucidation as well as assay of important pharmaceutical substances, namely :

- (i) To record differences in the magnetic properties of the various nuclei present,
- (ii) To deduce in large measure the exact locations of these nuclei within the molecule,
- (iii) To deduce how many different types of hydrogen environments are present in the molecule,
- (iv) To deduce which hydrogen atoms are present on neighbouring carbon atoms, and
- (v) To measure exactly how many H-atoms are actually present in each of these environments.

Example : Figure 23.2 depicts the NMR-spectrum of toluene ($C_6H_5-CH_3$), which essentially possesses *two* different species of H-atoms, for instance :

- (a) methyl hydrogen atoms ($-CH_3$), and
 (b) aromatic ring hydrogen atoms ($-C_6H_5$).

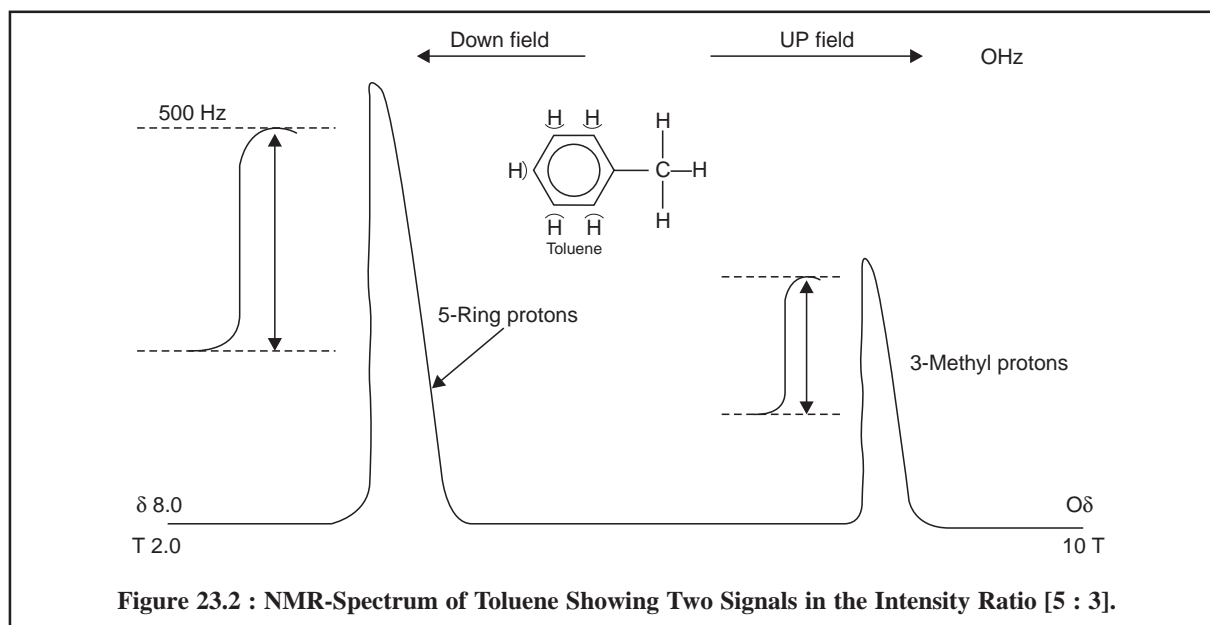

Hence, two signals will show-up in the NMR-spectrum corresponding to these two different chemical and magnetic environments. Furthermore, the areas under each signal are in the ratio of the number of protons in each part of the molecule, and thus actual measurement will reveal that the ratio of these areas is 5 : 3.

23.2. THEORY

Almost fifty per cent of the nuclei known so far behave as if they were spinning as a whole about an axis just like a minute bar magnet, the axis of which happens to be coincident with the axis of spin. The angular momentum of the charge created by the spinning electrons may be expressed in terms of spin quantum number designated as 'I' (in units of $h/2\pi$ where h is **Planck's constant**). Therefore, for a nuclei to exhibit NMR phenomenon the spin quantum number I is always greater than 0. The spin quantum number I is directly associated with the mass number and the atomic number of the nuclei. Pope *et al.* (1959) has put forward a detailed list of spin quantum values *vis-a-vis* mass number and atomic number so as to facilitate in establishing the value of I empirically as shown below :

Mass Number	Atomic Number	Spin Quantum Number
Odd	Odd or Even	$I = \frac{1}{2}$,
Even	Even	$I^* = 0$,
Even	Odd	$I = 1, 2, 3, 4 \dots$

*(i) The nuclei of such type of isotopes possess essentially a spherically symmetrical charge distribution, and

(ii) They do not have angular momentum, and hence do not give nuclear magnetic resonance spectra.

* Pope, J.A., Schneider, W.G. and Bernstein, H.J., **High Resolution Nuclear Magnetic Resonance**, London, McGraw-Hill, 1959.

From the above useful data provided one may draw an inference that spin numbers have either 'integral' or 'half-integral' values ranging from $\frac{1}{2}$ to at least $9/2$ for different nuclei. The spin number is obtained by the addition of individual protons and neutron spin numbers of $\frac{1}{2}$ each, with the restriction that neutrons can cancel only neutrons and protons can cancel only protons.

Precisely *three* classes of nuclei may be neatly distinguished, namely :

(a) **Zero-spin (I = 0)** : Those where both the number of protons and neutrons are even, for instance : ^{12}C , ^{16}O , and ^{32}S . Nuclei in this category do not interfere with a NMR-signal from other nuclei. In case, ^{12}C and ^{16}O has also been magnetic per chance, the NMR spectra of organic molecules certainly would have been much more difficult and complex.

(b) **Half-Integral Spin (I = $\frac{1}{2}$)** : Those where either the number of protons or the number of neutrons is odd. This constitutes the most important group of nuclei for their immense applications and utility to a medicinal chemist and an organic chemist.

*Examples** : They are ^1H ; ^3H ; ^{13}C ; ^{19}F ; ^{31}P ; ^{15}N ; ^{29}Si ;

(c) **Integral Spin (I = 1)** : Those where both the number of protons and the number of neutrons is odd.

Examples : Where $I = 1$, are : ^2H (Deuterium) and ^{14}N ; and where $I > 1$ are : ^{10}B ; ^{11}B ; ^{35}Cl ; ^{17}O ; ^{27}Al ;

In other words, isotopes having a spin value equal to, or greater than one exhibit an ellipsoidal charge distribution and have spin. They invariably possess a nuclear electric quadrupole moment, designated as 'Q'.

23.2.1. ORIENTATIONS OF MAGNETIC NUCLEUS UNDER B_0

Under the influence of external magnetic field, B_0 , a magnetic nucleus may take up different orientations with regard to that field, for instance :

(i) **Two orientations** : The number of possible orientation is given by $(2I + 1)$, so that for nuclei with spin $\frac{1}{2}$ e.g., ^1H , ^{13}C , ^{19}F only two orientations are allowed, and

(ii) **Three orientations** : Both ^2H (Deuterium) and ^{14}N have $I = 1$ and, therefore, can take up three orientations. These nuclei essentially possess both electric quadrupoles and magnetic dipoles.

23.2.2. PRECESSIONAL FREQUENCY (ν)

In any magnetic field, magnetic nuclei like the proton precess at a frequency ν , which is proportional to the strength of the applied field. The exact frequency is expressed by :

$$\nu = \frac{\mu\beta_N B_0}{hI}$$

where, B_0 = Strength of the external field experienced by the proton,

I = Spin quantum number,

h = Planck's constant (6.626×10^{-34} Js),

μ = Magnetic moment of the particular nucleus, and

β_N = Nuclear magneton constant.

* Harris, R.K. and B.E. Mann., 'NMR and the Periodic Table', New York Academic Press, 1978.

Table 23.1 records some typical approximate values of 'v' for (a) selected values of field strength B_0 , and (b) common magnetic nuclei.

Table 23.1 : Precessional Frequencies* as a Function of Increasing Field Strength

Bo/tesla (Nucleus)	External Magnetic Force					
	1.4	2.1	2.3	5.1	5.8	7.1
^1H	60	90	100	220	250	300
^2H	9.2	13.8	15.3	33.7	38.4	46.0
^{13}C	15.1	22.6	25.2	55.0	62.9	75.5
^{14}N	4.3	6.5	7.2	15.8	17.9	21.5
^{19}F	56.5	84.7	93.0	206.5	233.4	282.0
^{31}P	24.3	36.4	40.5	89.2	101.5	121.5

(Free Electron) 3.9×10^4

The data from Table 23.1, reveals that :

- magnetic moments of ^1H and ^{19}F are relatively large and, therefore, detection NMR-signals with these nuclei are fairly sensitive,
- Magnetic moment of ^{13}C is almost 1/4 that of ^1H *i.e.*, the former is less sensitively detected in NMR as compared to the latter,
- Similarly, magnetic moment of ^2H (Deuterium) is approximately 1/6th that of ^1H (less sensitively detected in NMR), and
- Even with very large magnetic fields, upto 7.1 T, the energy difference ($\Delta = h\nu$) is very small, upto 300 MHz ; because the difference is so small ($\approx 10^{-4}$ kJ mol $^{-1}$) the number of protons in the two energy states are almost equal.

23.2.3. SATURATION OF THE SIGNAL

It has been observed that nuclei in the lower energy state undergo transitions to the higher energy state. The populations of the two states may approach equality, and if this situation arises no further net absorption of energy take place, and the observed NMR resonance signal will fade out. This particular situation is termed as **saturation of the signal**.

It is pertinent to mention here that in a small NMR spectrum the populations in the two spin states never become equal, by virtue of the fact that higher energy nuclei are constantly returning to the lower energy spin state.

23.2.4. ABSORPTION POSITIONS IN NMR-SPECTRUM

For different types of organic compounds and pharmaceutical substances the resonance positions for protons lie usually within a narrow range (~ 600 Hz). As the differences in the signal's positions are small in comparison to the applied frequency (60×10^6 Hz or 60 MHz), therefore, the absolute measurements of absorption positions cannot be made with the required degree of accuracy (0.1 Hz 60×10^6 Hz, *i.e.*, 1 part in 10^8). However, it is quite possible to measure the differences in frequency relative to a standard substance with the required degree of accuracy and precision.

23.2.5. CHEMICAL SHIFT

The chemical shift (δ) is defined as the difference between the resonance position of a nucleus and that of a standard reference compound. It is normally expressed in terms independent of H_0 (or the related applied resonance frequency ν) :

* Precessional Frequencies in MHz

$$\text{Chemical shift } (\delta) = \frac{\Delta\nu \text{ (Hz)}}{\text{Applied resonance frequency} \times 10^6 \text{ (Hz)}} \times 10^6 \text{ ppm}$$

where, $\Delta\nu$ = Difference in frequency (Hz) between the observed signal and that of the standard (reference compound).

Reference Compound : For ^1H NMR *i.e.*, Proton-NMR, tetramethyl silane (TMS), $(\text{CH}_3)_4\text{Si}$, is employed mostly as the reference compound, because of the fact that its protons resonate at higher field strength than most other protons.

Convention for δ : TMS assigned ($\delta = 0$), values for other protons are measured positively downfield. In other words, increasing δ corresponds to increasing de-shielding of the nucleus.

23.2.6. SPIN-SPIN INTERACTIONS

High resolution NMR spectra very often exhibit signals as multiplets, invariably showing a more or less symmetrical appearance.

Multiplicity is brought about due to the splitting of the signal of one set of equivalent nuclei by the magnetic fields of adjacent sets of nuclei *i.e.*, **spin-spin interactions**. The distance between the peaks of a regular multiplet is termed as the coupling constant, designated as J , and measured in Hz.

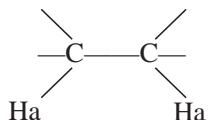

The protons H_a and H_b are totally in different chemical environments. There is a significant difference in their chemical shifts because of the variance in the resonance positions of their nuclei. Thus, H_a experiences a total magnetic field comprising of : external field (H_o) and local field due to H_b as shown in Figure 23.3.

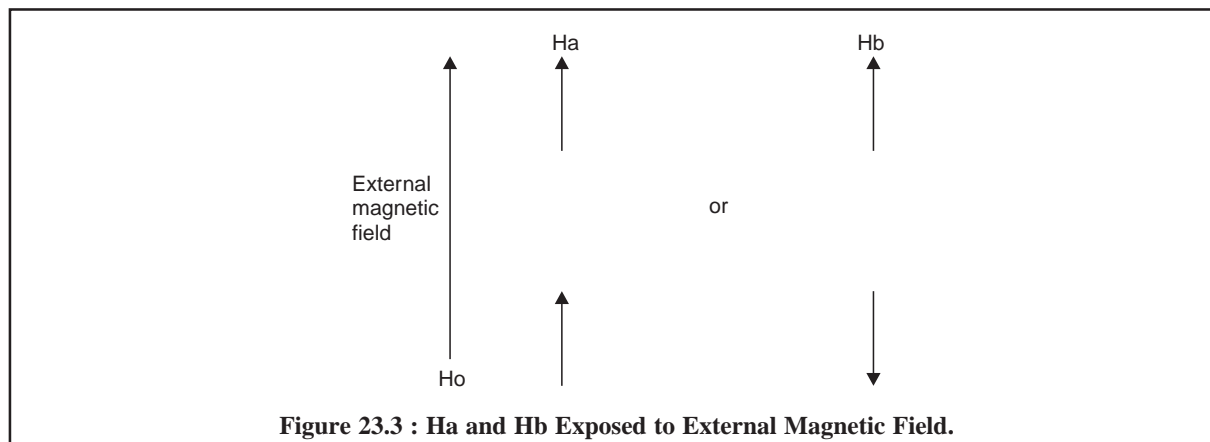

From Figure 23.3, it is evident that H_a , at a given constant, experiences the local field of H_b that may be either aligned with or against that of H_a .

The H_a signal is split into a doublet and the peaks of this doublet will be equal in height, because each alignment of spins has equal probability.



Based on the same reasonings, the signal emerged from H_b is split into a doublet as shown below :
The spin-alignments of H_{b1} and H_{b2} may be designated as :

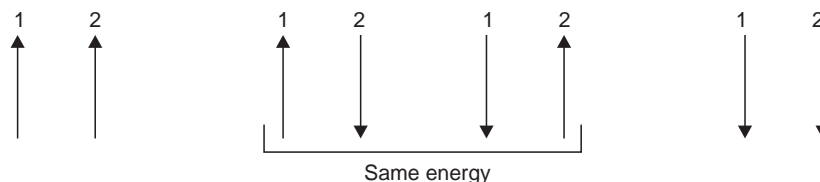

For H_a the corresponding energy levels would be as depicted below :

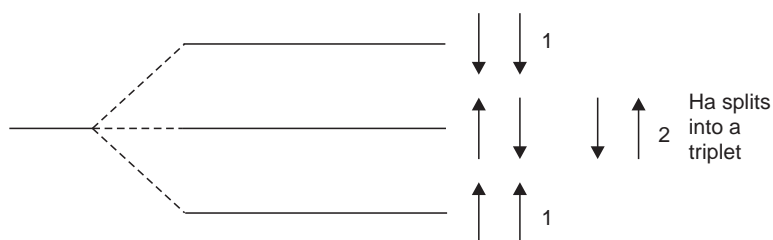

The probability of each of the above cited four spin arrangements is equal, two having the same energy ; thereby giving rise to a triplet for the signal of H_a, having peak heights in the ratio 1 : 2 : 1.

Therefore, generalizing the spin-spin interactions cause a signal to be split into $(n + 1)$ peaks, where 'n' is the number of interacting nuclei on the adjacent carbon atom.

Hence, *two* important observations are usually made, namely :

- (a) Coupling constant, J, is independent of H_o (contrast with δ), and
- (b) Regular multiplets are produced when the difference in chemical shifts (in Hz) between nuclei A and X (*i.e.*, $\Delta\nu_{AX}$) is large relative to the coupling constant J_{AX} , *i.e.*, when $\Delta\nu_{AX}/J_{AX} \geq \sim 10$.

The spectra obtained in this manner designated as First Order, and these may be analysed with the help of the following FOUR general RULES, namely :

RULE : 1 : Multiplets caused by mutual interaction of nuclei A and nuclei X have identical J values,

RULE : 2 : Interaction of nucleus A with a group of n magnetically equivalent nuclei X (of spin IX), produces a multiplet of $(2n_x I_x + 1)$ peaks,

RULE : 3 : Intensities of the multiplet are asymmetrical about the mid-point of the signal, that corresponds to the origin of the multiplet and is equal to the chemical shift.

Pascal's Triangle : The nuclei having spin quantum number $I = 1/2$, relative intensities of the multiplet's peak are given by the coefficients of the binomial expansion, $(1 + x)^n$, where n = number of nuclei interacting with the specific nucleus emitting the signal ; or by **Pascal's Triangle** as given below :

$n = 0$		1		singlet			
$= 1$		1	1	doublet			
$= 2$		1	2	1	triplet		
$= 3$		1	3	3	1	quartet	
$= 4$		1	4	6	4	1	quintet

RULE : 4 : Interaction is normally observable between close groups of magnetically non-equivalent nuclei.

This chapter exclusively deals with nuclei of spin 1/2 and, therefore, the examples and applications shall be given from ^1H *i.e.*, **proton magnetic resonance (PMR) spectroscopy**.

However, a brief description of the following *three* types of NMR-spectroscopy will be made here so as to apprise the readers about their principles and main usages only, such as :

- (i) ^3H -NMR (Tritium NMR Spectroscopy),
- (ii) ^{13}C -NMR Spectroscopy, and
- (iii) 2D-NMR (Two Dimensional Correlation Spectroscopy ; or Two Dimensional COSY Spectrum).

23.2.7. ^3H -NMR (TRITIUM NMR-SPECTROSCOPY)

The ease with which '**tritium**' could be employed for labelling organic compounds, having fairly high molar specific activity, has turned it into a very useful and versatile β -emitting radionuclide for chemical and life sciences research. The unique novel characteristic feature of tritium tracers being that it may be used as a tracer for carbon as well as hydrogen structures. A non-destructive method of analysis was initiated in Great Britain* employed elaborated sophisticatedly designed instrumentations** armed with '**supercon**' magnets and latest computer technology.

The comprehensive dedicated research ultimately made it possible to decode the patterns of labelling in almost any type of tritium labelled compound at low isotopic abundance (*e.g.*, 3×10^{-4} to 3×10^{-2} per cent. ^3H per site) with the aid of ^3H -NMR directly, rapidly, reliably and non-destructive analytical means. Since, 1971, the ^3H -NMR spectroscopy, utilizing only millicurie (mCi) quantities of radioactivity, emerged as a most useful analytical tool for the study of tritium labelled compounds.

The *two* major advantages of ^3H -NMR spectroscopy based on the characteristic magnetic features of the tritium nucleus are, namely :

- (a) High receptivity of the tritium nucleus, *i.e.*, only small amounts of radioactivity (0.1 to 10 mCi per site, 3.7 to 370 MBq) are needed to bring about a well-defined spectrum, and
- (b) Similarity of the chemical shifts of ^3H nuclei and those of ^1H nuclei (protons) *i.e.*, the copious volume of available data on 'proton-chemical shifts' may be applied directly for the interpretation of ^3H -NMR spectra. In other words no new correlations need to be determined, as in the case for ^{13}C -NMR-sepectroscopy.

The various advantages of ^3H -NMR spectroscopy are, namely :

- a rapid direct and non-destructive method,
- provides direct information on regiospecificity,
- gives quantitative distribution of the label,
- caters for accurate and precise information on the stereochemistry of the label, and
- requires only millicuries (mCi) rather than microcuries or lesser amounts of radioactivity.

Table 23.2, records the nuclear properties of ^1H , ^3H (T) and ^{13}C isotopes being employed particularly in various arms of '**Life Sciences**' :

* Amersham International plc & Dept. of Chemistry, University of Surrey, (UK)—a collaboration project (1968) ;

** A solid-state 90 MHz Fourier Transform Instrument with a 96 MHz channel for ^3H observation, proton-spin decoupling and a ^2H field-frequency lock with computer control and hard-disc storage of acquired data.

Table 23.2 : Nuclear Characteristics* of ^1H , ^3H (T) and ^{13}C Isotopes Employed Specifically in 'Life Sciences'

S. No.	Nuclear Characteristics	^1H	$^3\text{H(T)}$	^{13}C
1.	Natural Abundance (%)	99.984	$< 10^{-16}$	1.11
2.	Nuclear spin	$\frac{1}{2}$	$\frac{1}{2}$	$\frac{1}{2}$
3.	Magnetic momentum ($\mu/\mu\text{N}$)	4.8371	5.1594	1.2162
4.	Magnetogyric ratio ($\gamma/10^7$ radians $\text{T}^{-1}\text{s}^{-1}$)	26.7519	28.5336	6.7263
5.	Resonance frequency (MHz at 2.114 T)	90.0	96.0	22.6
6.	Relative sensitivity for equal numbers of nuclei at constant field	1.0	1.21	1.59×10^{-2}
7.	Half-life	—	12.43 y	—
8.	Radiation	Stable	—	Stable
9.	Maximum (MeV)	—	0.018	—

23.2.8. ^{13}C -NMR-SPECTROSCOPY

The 'carbon-skeleton' has been viewed directly with the help of Carbon-13 NMR spectroscopy on a particle basis since early 1970's ; whereas ^1H -NMR spectrometry started in late 1950's. The valuable contribution made by various researchers**, between 1976 and 1980, has virtually placed ^{13}C -NMR to a strategically much advanced stage where it gives a clear edge over ^1H -NMR in terms of not only its versatility but also its wide application in analysis.

^{13}C -NMR refers to recording another NMR-spectrum but of the C-13 atoms rather than the hydrogen atoms. In actual practice, however, -'these spectra are recorded in such a manner that each chemically distinct carbon gives rise to single peak, without any coupling or fine structure'.

Hence, simply a count of the peaks can be used to see how many carbons are actually present in the molecule. But this particular technique is not reliable for a molecule that exhibits symmetry, because this would ultimately reduce the number of peaks.

It is interesting to note that ^{12}C nucleus is not magnetically 'active' (spin quantum number $I = 0$), whereas the ^{13}C nucleus, like the ^1H nucleus, has a spin number $I = \frac{1}{2}$. Keeping in view the nuclear characteristic features one may observe that the natural abundance of ^{13}C is equal to 1.1% that of ^{12}C and also the sensitivity of ^{13}C is equal to 1.6% that of ^1H . Therefore, the overall sensitivity of ^{13}C compound with ^1H stands at 1/5700.

There are *three* short-comings of ^{13}C -NMR spectra, namely :

- (1) Only 1% of the carbon in the molecule is carbon-13,
- (2) Sensitivity is consequently low, and
- (3) Recording the NMR-spectra is a tedious and time consuming process. However, with the advent of recent developments in NMR-spectroscopy it is quite possible to eliminate some of these short comings adequately. They are :

* Harris, RK, NMR and the Periodic Table, **Chem. Soc. Rev.**, 5, 1, 1976

Weast, RC, **Handbook of Chemistry and Physics**, 62nd, ed., Cleveland, CRC-Press, 1981-1982.

** Wehrli, FW, and T. Wirthin., '**Interpretation of Carbon-13 NMR spectra**', London, Heyden, 1976

Abraham, RJ, and P. Loftus., '**Proton and Carbon-13 NMR spectroscopy**', London, Heyden, 1978

Levy, GC, RL Lichter, and GL Nelson, '**Carbon-13 Nuclear Magnetic Resonance**, 2nd, ed., New York, Wiley-Interscience, 1980.

- (a) Development of powerful magnets ('**supercon**' magnets) has ultimately resulted in relatively stronger NMR-signals from the same number of atoms,
- (b) Improved hardware in NMR-spectroscopy has gainfully accomplished higher sensitivity, and
- (c) Development of more sensitive strategies has made it possible to record these C—H correlation spectra in a much easier manner.

Therefore, it is now possible either to record the ^{13}C -NMR signal and place the hydrogens in the undetected '**second dimension**' or to record the signal from the hydrogens and place the ^{13}C resonances in the '**indirect dimension**'.

In actual practice, the latter mode is technically more demanding and affords results that are much higher in sensitivity. Recent developments in NMR-spectrometer hardware and technique have made this more-sensitive-mode of operation, termed as '**inverse-detection**', rather readily applicable to modern analysis.

23.2.9. 2D-NMR (TWO DIMENSIONAL CORRELATION SPECTROSCOPY OR TWO DIMENSIONAL COSY SPECTRUM)

The interaction between different hydrogens in a molecule, known as '**scaler**' or '**spin-spin coupling**', transmitted invariably through chemical bonds, usually cover 2 or 3 at the most. Therefore, when a hydrogen with a chemical shift 'A' is coupled to a hydrogen with chemical shift 'B', one would immediately make out that the hydrogens must be only 2 or 3 bonds away from one another. To know exactly with particular hydrogens are coupled to one another it is necessary to record a two-dimensional '**Correlation Spectroscopy**' (COSY) spectrum.

Generally, a normal NMR-spectrum has amplitude plotted *Vs* just one frequency-dimension (the ppm scale). In 2D-NMR, the amplitude is plotted *Vs* two frequency-dimensions (two ppm scales), normally in the form of a counter plot, just like a topographic map.

The most important aspect about these 2D-NMR spectra is that they show the relation between the peaks in an NMR-spectrum.

Example : A peak at ordinate A ppm in one dimension and B ppm in the other simply indicates that a hydrogen with shift A is duly coupled to a hydrogen with shift B. In short, this is all the information which one needs to interpret in a COSY-spectrum. Thus, the resulting chemical shifts of coupled protons may be simply read off the spectrum.

Figure 23.4, illustrates the two dimensional COSY spectrum of a sugar : 1-0-methyl α -D-glucopyranoside (1) that has been recorded on a 400 MHz NMR-spectrometer ; the sample was dissolved in D_2O so that the OH protons get duly exchanged with Deuterium and are, therefore, not seen at all. Besides, the ^1H -NMR-spectrum has also been shown alongside both axis of the two dimensional spectrum in Figure 23.4.

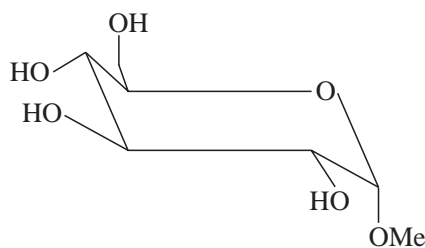

1-0-Methyl α -D-glucopyranoside

Salient features of ^1H -NMR and 2D-NMR spectra are, namely :

1. At 3.25 ppm a sharp intense peak, labelled B, is characteristic of an —OMe moiety,

- At 4.6 ppm there appears another strong peak which is due to the presence of some residual HDO in the D_2O that was initially employed to dissolve the sample,
- At 4.65 ppm, the two peaks or multiplets are due to H which are distinctly separated from the rest of the spectrum. These are known to belong to the aromatic proton H_1 which is present adjacent to two oxygen atoms, and
- The COSY-spectrum (Figure 23.4) depicts a so called cross-peak CH at $F_1 = 4.65$ ppm ; $F_2 = 3.4$ ppm which means that the proton is coupled to another proton whose shift is 3.4 ppm.

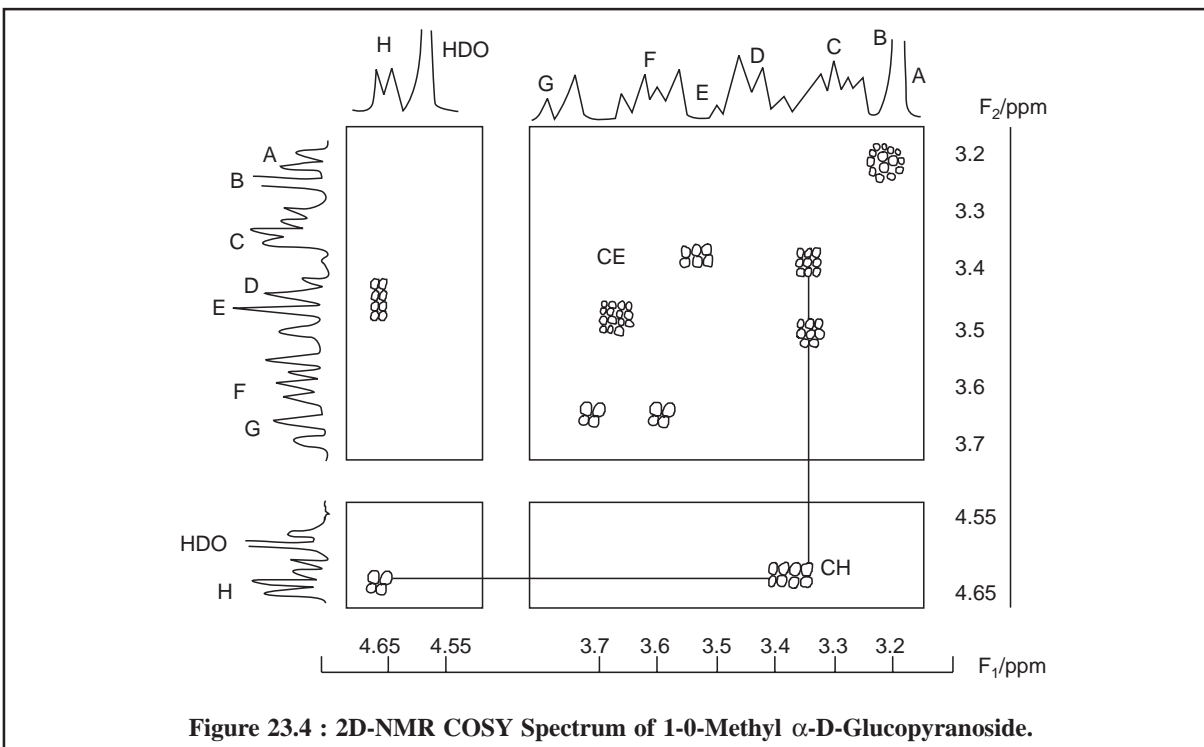

Thus, looking at the structure of compound (1), the resonance C at 3.4 ppm may be due to H_2 by connecting it to H_1 .

Following along it may be observed that from multiplet C there exists another cross-peak, CE at $F_1 = 3.5$ ppm, $F_2 = 3.4$ ppm, suggesting thereby that the proton resonating at 3.4 ppm is duly coupled to one resonating at 3.5 ppm ; this identifies multiplet E as H_3 . In fact, from this single COSY-spectrum (Figure 23.4) one may identify the complete chain of coupled protons as it goes round the pyranose ring.

However, in actual practice with a little skill and expertise one may :

- Read off the bonding network from the spectrum,
- Interpret a COSY spectra easily, because without it finding the coupled pairs of hydrogens is mostly not only ambiguous but also time-consuming, and
- Reveal a few chains of coupled resonances.

23.3. INTERPRETATION OF A NMR-SPECTRUM

The interpretation of a NMR-spectrum can be accomplished by determining the following parameters for each signal methodically as described below :

23.3.1. CHEMICAL SHIFT (δ) (RELATIVE TO REFERENCE COMPOUND, USUALLY Me_4Si)

The chemical shift indicates the environment of the proton. One may refer to the tables and charts in various reference books* for approximate ranges of δ for ^1H in different environments.

23.3.2. RELATIVE PEAK AREA

This is equal to the height of step of the integration trace.

In fact, peak area is proportional to the number of protons causing the signal. Always look for simple ratios *e.g.*, 3 : 1, rather than (say) 14 : 4. A strong singlet (or upfield triplet) may indicate CH_3 ; the corresponding integration steps provide a good starting point for ascertaining the relative number of protons present in the molecule under investigation.

23.3.3. MULTIPLICITY OF THE SIGNAL

The number of peaks in a regularly split signal (*e.g.*, a regularly spaced triplet, quartet etc.,) or other recognisable splittings (*e.g.*, doublet of doublets etc.,), should be noted carefully.

Therefore, multiplicity and the relative peak heights in a multiplet provide an useful additional check on the relative number of protons obtained from the integration of peak areas.

Thus, coupling ^1Ha to another ^1Hb may give rise to a doublet or a triplet or a doublet-of-doublet as shown below :

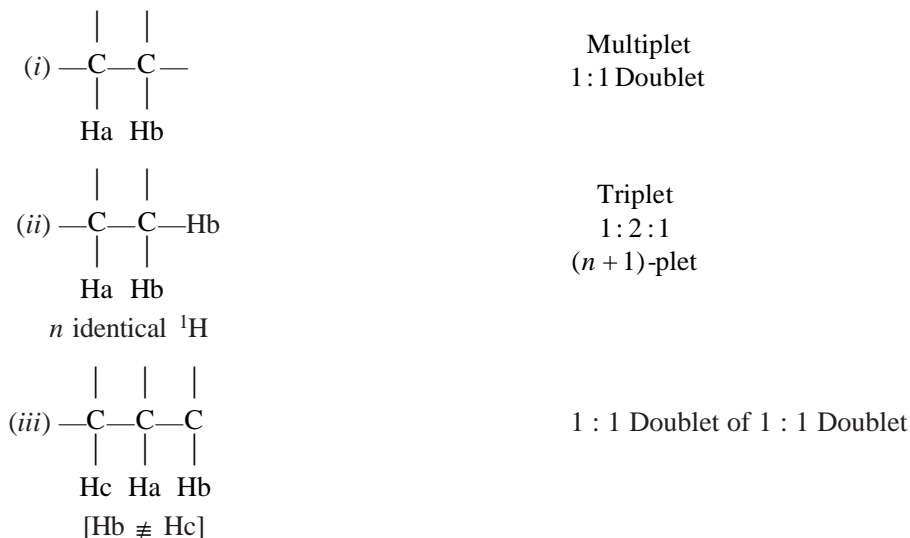

n protons different from ($n + 1$)-plet of ($m + 1$)-plets where m other protons.

23.3.4. COUPLING CONSTANT (J)

It represents regular multiplets. Actually, J is the separation (in Hertz ; $\text{Hz} = \text{sec}^{-1}$) between the peaks of regular multiplets.

The coupling constants help in the identification of the coupled nuclei because $J_{ab} = J_{ba}$: and are therefore, useful in characterizing the relative orientations of interacting protons.

* Silverstein, R.M. and G.C. Basler, **Spectrometric Identification of Organic Compounds**, New York Wiley, 1968.
Jackman, L.M. and S. Sternhell, **Applications of NMR Spectroscopy in Organic Chemistry**, London, Pergamon Press, 1969.

A few examples of ^1H coupling constants, J (Hz) are given below :

C—C Linkages	Value of J	C—C Linkage	Value of J
$\begin{array}{c} \text{C} - \text{C} \\ \quad \\ \text{H} \quad \text{H} \end{array}$	7	$\begin{array}{c} \text{CH} \\ \diagup \\ \text{C} = \text{C} \\ \diagdown \\ \text{H} \end{array}$	4—10
$\begin{array}{c} \text{C} - \text{C} - \text{C} \\ \quad \quad \\ \text{H} \quad \text{H} \quad \text{H} \end{array}$	0	$\begin{array}{c} \text{H} \quad \quad \text{H} \\ \diagdown \quad \diagup \\ \text{C} = \text{C} \\ \text{(cis-)} \end{array}$	6—14
$\text{HC} = \begin{array}{l} \diagup \text{CH} \\ \diagdown \end{array}$	0.5—2	$\begin{array}{c} \text{H} \quad \quad \quad \\ \diagdown \quad \quad \diagup \\ \text{C} = \text{C} \\ \text{(trans-)} \\ \quad \quad \quad \text{H} \end{array}$	11—20
$\text{C} = \text{C} \begin{array}{l} \diagup \text{H} \\ \diagdown \text{H} \end{array}$	0—3		

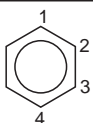

$\left. \begin{array}{l} 1, 2 \sim 8 \\ 1, 3 \sim 2 \\ 1, 4 \sim 0 \end{array} \right\} \text{Value of } J$

23.4. INSTRUMENTATION

The NMR-spectrum can be scanned either by changing the frequency of the radio-frequency oscillator or by changing the spacing of the energy levels while making a small change in the applied magnetic field.

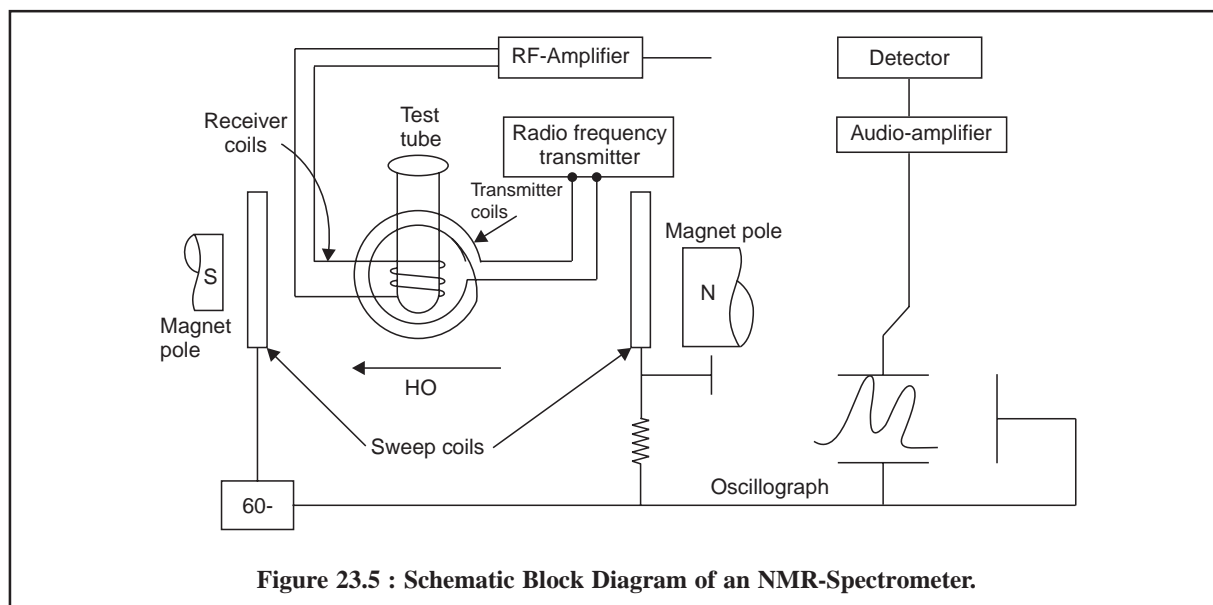

Figure 23.5 : Schematic Block Diagram of an NMR-Spectrometer.

The sample is introduced in a test-tube between the pole faces of a DC-electromagnet whose gap field can be varied from zero upto 14,092 gauss and even scaled upto 23,000 gauss in sophisticated versions of the instrument. The pole pieces are nearly 12 inches in diameter and are spaced approximately 1.75 inches apart. In order to flip the rotating nuclear axis with regard to the magnetic field an oscillating radio-frequency field, supplied by low power, crystal-controlled oscillator is strategically placed at right angles that would be perpendicular to the plane of the paper. The coil that transmits the radio-frequency field is made into two-halves to allow insertion of the sample holder, and the two halves are placed in the gap of the magnetic poles.

Coils located within the pole gap allow a sweep to be made through the applied magnetic field that produces resonance in the range of precession frequencies.

A few turns of wire wound tightly around the sample tube forms a separate radio-frequency coil which picks up the resonant signals emitted from the sample. The receiver coil is perpendicular to both the stationary field and the radio-frequency transmitter coil so as to minimise pick-up from these fields. Thus, energy is absorbed from these receiver coils when nuclear transitions are induced. Absorption of energy causes the radio-frequency voltage across the receiver coil to drop. This voltage change is amplified and detected by a high-gain-radio frequency amplifier and a diode-detector which is tuned to the same frequency as the radio frequency transmitter.

The resulting DC-voltage is placed on the vertical plates of an oscilloscope to produce an intensity as a function of frequency which is nothing but the desired NMR-spectrum.

23.5. APPLICATIONS OF NMR-SPECTROSCOPY IN PHARMACEUTICAL ANALYSIS

NMR-spectroscopy has been extensively employed for the identification testing as well as quantitative analysis of pharmaceutical substances. These *two* aspects shall be discussed in the sections that follow :

23.5.1. IDENTIFICATION TESTING

The versatility and ability of NMR to distinctly differentiate nuclei in various intramolecular environments has placed it as the most reliable and dependable technique for carrying out the identification testing of a host of pure drugs. Hence, any apparent deviations of the spectrum of a sample under investigation *vis-a-vis* the spectrum of the pure and the authentic pharmaceutical substance usually give rise to an enormous information not only confined to the true identity of the substance but also the probable nature of the impurities it possesses.

The survey of literature provides ample evidence of the NMR spectra of a good number of medicinal compounds belonging to various categories, namely : sulphonamides ; barbiturates* ; amphetamines** ; steroids ; antihistamines*** ; penicillins and cephalosporins**** to name a few.

23.5.2. ASSAY OF DRUGS

A plethora of pure drugs, their respective combinations and their dosage forms have been assayed by NMR-spectroscopy quantitatively by various researchers and the result(s) thus obtained were duly verified and compared with the standard methods prescribed in various *official compendia*. A few typical examples of such drugs shall be described briefly here :

A. Quinidine in Mixtures and Hydroquinidine*****

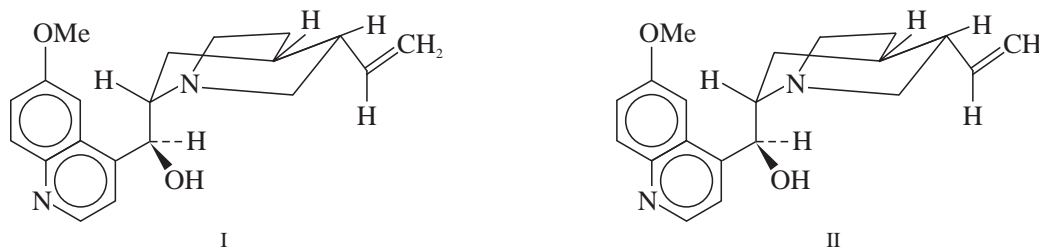

* Fratiello, A., M. Mardirossian and E. Chavez., *J. Magn. Reson.*, **12**, 221, 1993.

** Warren, RJ, PP Bagosh and J.E. Zarembo, *J. Assoc. Offic. Anal. Chem.*, **54**, 1179, 1971.

*** Chang, CJ and CE Peck, *J. Pharm. Sci.*, **65**, 1019, 1976.

**** Wilson, WL, HW Avodich and D.W. Hughes, *J. Assoc. Offic. Anal. Chem.*, **57**, 1300, 1974.

***** Huynh-Ngoc, T. and G. Sirois, *J Pharm. Sci.*, **62**, 1334, 1973.

A given sample containing a mixture of quinidine (I) and hydroquinidine (II) is dissolved in requisite quantity of deuteriochloroform (CDCl_3) along with 2, 3, 5-tribromothiophene as the **internal standard**. The quantitative determination is carried out by comparing the peak area attributed by ethylene of (I) at 5.16 ppm to the internal standard peak at 6.93 ppm. The coefficient of variation was found to be 1%.

B. Assay Methsuximide and Phensuximide Capsules*

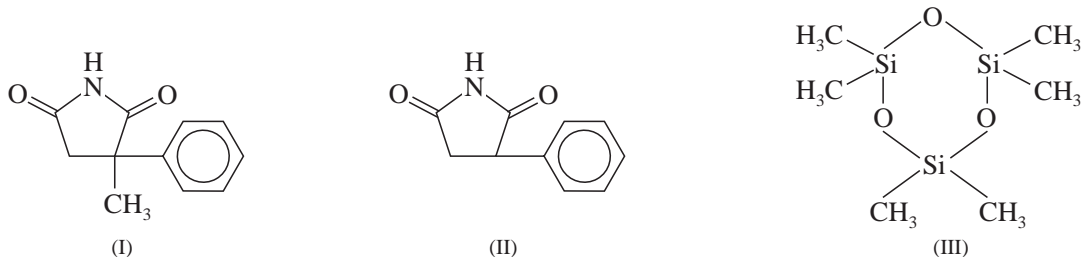

The analysis of methsuximide (I) is performed in carbon tetrachloride and of phensuximide (II) in 10% v/v dichloromethane in carbon tetrachloride. In this particular analysis hexamethylcyclotrisiloxane (III) is employed as an **internal standard** for (I) and (II); whereas the frequencies are referenced to usual tetramethylsilane (TMS).

C. Assay of Trimethoprim and Sulphamethoxazole in Tablets and Powders**

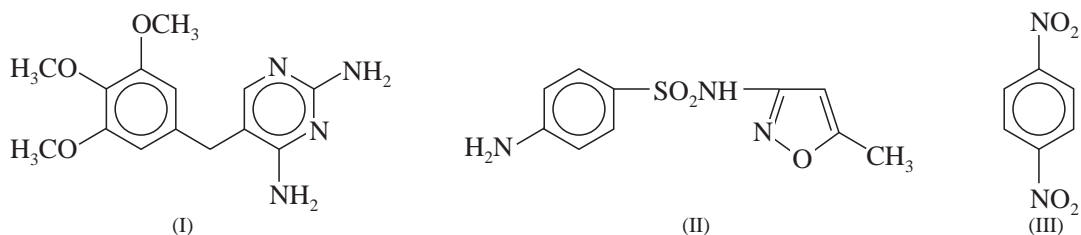

The simultaneous assay of trimethoprim (I) and sulphamethoxazole (II) present either in tablets or powder may be done effectively by NMR method.

Here, a powdered sample comprising 1 mg of (I), 50 mg of (II), and 30 mg of pure 1,4-dinitrobenzene (III) as **internal standard** is carefully dissolved by heating in 1 ml of dimethylsulphoxide- d_6 and subsequently centrifuged to eliminate solid residues, if any. For trimethoprim (I): the assay is solely based on the singlets at 3.40 and 3.55 ppm on account of the aromatic and methoxy protons of (I) respectively. For sulphamethoxazole (II) the singlet at 2.3 ppm is particularly due to the methyl group of (II); and the singlet at 8 ppm is due to (III). It is, however, pertinent to mention here that the assay results were fairly in agreement with British Pharmacopoeial method of analysis. Finally, the NMR-spectroscopic method coefficient of variation was found to be only 0.9%.

D. Assay of Meprobamate and Mebutamate

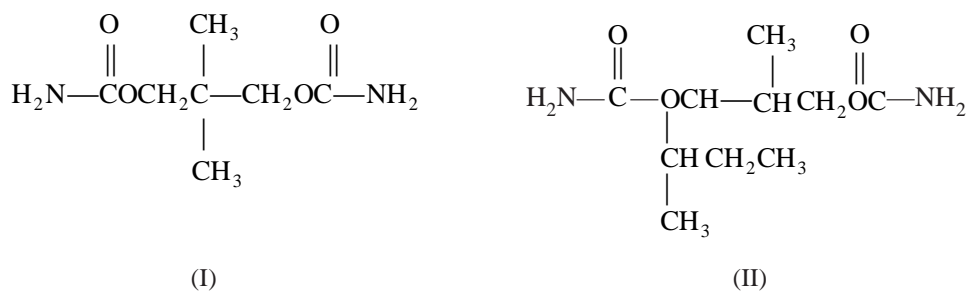

* Turczan, JW and BA Coldwitz, *J. Pharm. Sci.*, **62**, 1705, 1973.

** Rodriguez, MR, MT Pizzorna and S.M. Albonico, *J. Pharm. Sci.*, **66** 121, 1977.

The assay of meprobamate (I) and mebutamate (II) have been accomplished* by using malonic acid as the **internal standard** and acetone as the solvent. The results obtained were fairly comparable to the lengthy official procedures.

E. Assay of Meclizine and Methaqualone

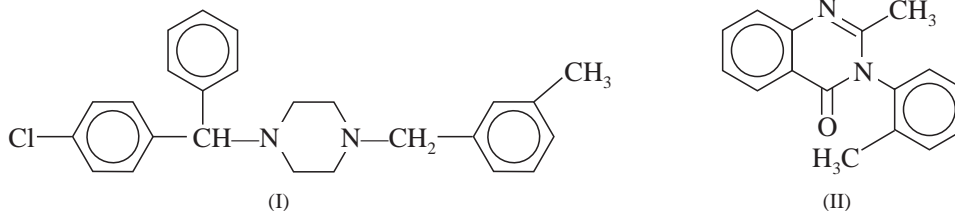

NMR-assay of meclizine (I) and methaqualone (II), besides a number of other potent hypnotics and their corresponding mixtures have been successfully carried out using an external standardization procedure reported**. It is, however, interesting to observe that additional sources of variability are usually incorporated into an assay employing external standardization, and the same has been duly shown in the results thus obtained *i.e.*, a large coefficient of variation to the extent of 4% achieved.

F. Assay of Iodine Values of Natural Oils

Natural oils like : olive, peanut, sunflower seed contain mostly the triglycerides, which usually give rise to *four* characteristic sets of signals in their corresponding PMR-spectra due to the resonance of alkenyl protons, namely :

- (i) 4, C-1 glyceride methylene protons,
- (ii) 1, C-2 glyceride methylene proton,
- (iii) Methylene protons directly linked to a double-bond, and
- (iv) Remaining protons on saturated carbon atoms.

Hence, it is possible to measure accurately the integration curve given out by the combined C-1, and C-2 glyceride methylene protons that occurs almost separately at 4. Now, employing these as an internal calibration one may determine conveniently the following *two* vital informations, such as :

- (a) the total number of alkenyl protons, which is a measure of degree of unsaturation, and,
- (b) the total number of protons, which is a measure of the average molecular weight.

Thus, the iodine values assayed (calculated) from the alkenyl proton integration*** and the corresponding molecular weight match quite favourably with the results obtained by Wijs Method as shown below :

Natural Oils	NMR-Method	Wijs Method
Olive Oil	80.8 ± 0.9	83.0-85.3
Peanut Oil	94.5 ± 0.6	95.0-97.2
Sunflower Seed Oil	135.0 ± 0.9	135.0-137.7

In addition to the above cited typical examples there are a quite a few other drug substances which have been duly assayed by NMR-spectroscopy, thus suggesting the versatility of this technique as an important analytical tool.

* Turezan, JW and TC Kram, **J. Pharm. Sci.** **56**, 1643, 1967.

** Rucker G. and PN Natrajan, **Arch Pharm.**, **300**, 276, 1967.

*** Johnson, LF and JN Shoolery, **Analyt. Chem.**, **34**, 1136, 1962.

THEORETICAL AND PRACTICAL EXERCISES

1. What do you understand by NMR-Spectroscopy ? Discuss the NMR-phenomenon including the following vital aspects :
 - (i) Spinning Nucleus,
 - (ii) Effect of an External Magnetic Field,
 - (iii) Precessional Motion,
 - (iv) Precessional Frequency, and
 - (v) Energy Transitions.
2. Explain the following terminologies usually encountered in NMR-Spectroscopy :
 - (a) Spin quantum number,
 - (b) Chemical shift,
 - (c) Spin-spin interactions, and
 - (d) Pascal's triangle.
3. Discuss expatiately the underlying variants with respect to NMR-Spectroscopy :
 - (a) ^3H -NMR,
 - (b) ^{13}C -NMR,
 - (c) 2D-COSY SPECTRUM.

Give suitable examples whereve necessary to justify your plausible explanation.
4. What essential steps you would consider in order to interpret a NMR-spectrum ? Explain.
5. Explain with the help of a neat, labeled, schematic block diagram of an NMR-Spectrometer ; and describe its operational modalities briefly.
6. Can one make use of NMR-Spectroscopy as an '**identification testing**' method for pharmaceutical substances ? Explain with typical examples.
7. How would you carry out the '**assay**' of the following pharmaceutical products :
 - (a) Quinidine in mixtures of hydroquinidine,
 - (b) Methsuximide and Phensuximide Capsules,
 - (c) Trimethoprim and Sulfamethoxazole Tablets,
 - (d) Meprobamate and Mebutamate, and
 - (e) Meclizine and Methaqualone.

Explain with procedural details sequentially.
8. Is it possible to exploit NMR-spectroscopy in the '**assay**' of **iodine values** of Natural Oils ? Explain with theoretical aspects and typical examples.

RECOMMENDED READINGS

1. Bhacca, NS and DH Williams, **Applications of NMR-Sectroscopy in Organic Chemistry, Illustrated from the Steroid Field**, San Fransisco, Prentice-Hall, 1964.
2. Jackman, LM and S. Sternhell, **Application of Nuclear Magnetic Resonance in Organic Chemistry**, 2nd., ed., New York, Oxford, 1969.
3. Flynn, EH, **Cephalosporins and Penicillins**, Yew York, Academic Press, 1972.
4. Heftmann, E., Ed., **Modern Methods of Steroid Analysis**, New York, Academic Press, 1973.
5. Kasler, F., **Quantitative Analysis by NMR-Spectroscopy**, London, Academic Press, 1973.
6. Chamberian, NF, **The Practice of NMR-Spectroscopy**, New York, Plenum Press, 1974.
7. Evans, EA, DC Warrell, JA Elvidge and JR Jones, **Handbook of Tritium NMR-Spectroscopy and Applications**, New York, John Wiley and Sons, 1985.

24 EMISSION SPECTROSCOPY

CONTAINS :

- 24.1 Introduction
- 24.2 Theory
- 24.3 Instrumentation
 - 24.3.1 Excitation sources
 - 24.3.2 Electrodes
 - 24.3.3 Sample handling
 - 24.3.4 Monochromators
 - 24.3.5 Detectors
 - 24.3.6 Spectrographs
- 24.4 Applications of Emission Spectroscopy

24.1. INTRODUCTION

Emission spectroscopy is exclusively related to atoms whereas a number of other spectroscopic techniques deal with molecules. The fundamental fact of emission spectroscopy is very simple, wherein the atoms present in a sample undergo excitation due to the absorption of either electrical or thermal energy. Subsequently, the radiation emitted by atoms in an excited sample is studied in an elaborated manner both qualitatively and quantitatively. Therefore, emission spectroscopy is considered to be a useful analytical tool for the analysis of :

- (i) elemental analysis of metals,
- (ii) identification and quantitative determination of metallic elements,
- (iii) estimation of metalloids *e.g.*, arsenic, silicon, selenium, present in extremely low concentrations, and
- (iv) analysis of solids, liquids or gases as follows :
 - solids-as such or evaporated solutions,
 - liquids-atomized spray, analyzed occasionally, and
 - gases-analyzed rarely.

In short, emission spectroscopy is considered to be the most accurate, precise and reliable means of quantitative analysis of elements as on date. If proper skill, precautions and wisdom are applied together this method may be adopted safely and conveniently to analyze approximately seventy elements from the '**periodic table**' at a concentration as low as 1 ppm.

24.2. THEORY

The theoretical aspects of emission spectroscopy may be categorized into the following *four* heads, namely :

- (a) **Spectra** : A beam of light on being passed either through a Nicol's prism or a grating, is split-up right into its constituent array of colours frequently termed as **spectrum**. However, the complete

spectrum has a wide range that may be further divided into various regions based on their respective wavelengths (0 to 35,000° A) :

- (i) **Ultraviolet Region** : It embraces radiations of wavelengths between 0 to 4000° A,
 - (ii) **Visible Region** : It includes radiations of wavelengths between 4000 to 7300° A, and
 - (iii) **Infrared Region** : It has radiations of wavelengths between 7300 and 35,000° A.
- (b) **Classes of Spectra** : There exist, in fact, two major types of spectra commonly termed as *emission spectra* and the *absorption spectra* which shall be discussed briefly as follows below :
- (i) **Emission Spectra** : An element on being heated to a very high temperature either by electrical method or a thermal method-usually emits light. This particular light after passing through either a prism or a grating when studied directly with the help of a spectroscope, gives rise to a spectrum, that is termed as **emission spectrum**.
 - (ii) **Absorption Spectra** : A source of light emits a continuous spectrum when first made to pass through an absorbing substance and subsequently through a spectroscope. It has been noticed that a few lines are missing in the observed spectrum thereby leaving either dark bands or lines at their respective places. Because the light of wavelength exactly corresponding to these dark bands (or lines) is found to be absorbed by the substance through which light is passed, the resulting spectrum is called as an **absorption spectrum**.
- (c) **Classification of Emission Spectra** : The emission spectra may be classified into the following *three* types, namely :

- (i) **Band Spectra (or Molecular Spectrum)** : Each molecule upon excitation gives out a band spectrum (or bands) that are characteristics of the molecule. In fact, a band spectrum comprises of groups of lines so near to one another that under normal circumstances they more or less seem to appear as continuous bands.

However, in emission spectroscopy the band spectra provided by molecules may be eliminated completely by giving energy to the corresponding molecules so that they may be split-up into separate atoms.

- (ii) **Continuous Spectra** : A continuous emission spectrum is obtained when solids are heated to incandescence. The thermal radiation of this nature is termed as black-body radiation, which has the following *three* characteristic features, namely :
 - (a) Dependent more on the temperature of the emitting surface than the material of which the surface is made of,
 - (b) Caused by the innumerable atomic and molecular oscillations excited in the condensed solid by the thermal energy, and
 - (c) Independent of the chemical composition of the substance.

Example : Incandescent solids, *e.g.*, carbon and iron give rise to continuous emission spectra when they are heated until they glow.

Hence, it is pertinent to mention here that the continuous spectrum cannot be employed effectively for spectrochemical analysis and these spectra may be eliminated completely by volatilizing the material (sample) before excitation.

- (iii) **Line Spectra** : Line spectra are usually encountered when the light emitting substance *i.e.*, the radiating species are separate atomic entities (particles) which are distinctly separated from one another, as in gas. Therefore, it is invariably known as 'atomic spectrum'. As the line spectrum depends solely upon the type of an atom, hence it enjoys the status of a predominant type of emission spectroscopy.

Bohr's theory rightly explains the fundamental origin of '**line spectrum**' according to which :

- An atom in the ground state has its electrons present in the lowest permitted energy-levels,
- An excited atom (by thermal or electrical means) has its electrons migrate from inner orbitals (specifically valence electrons) to outer orbitals,
- The excited electrons quickly give a photon of energy of immediately take the position in an orbital having the lowest energy (or ground state), and
- The emission of radiation from the excited atoms give rise to distinct spectral lines thereby forming the basis of emission spectroscopy.

Figure 24.1, depicts the energy-level diagrams both for an atom and a simple molecule illustrating the source of a line-spectrum and a band-spectrum as discussed above in (iii) and (i).

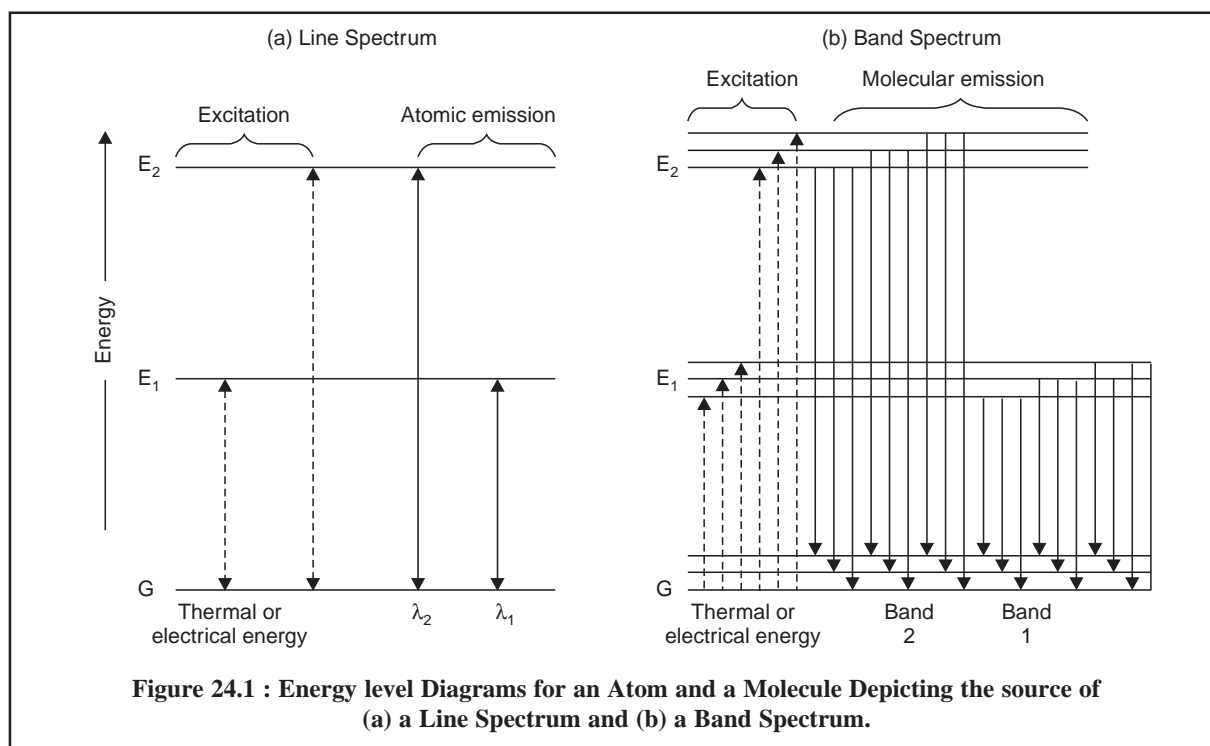

Figure 24.1 (a), designates the energy level diagram displaying the source of the lines in a typical spectrum of an element, where :

G = The horizontal line represents the ground state energy or the lowest energy of an atom (say Na atom), and

E_1 and E_2 = Represent the two higher energy electronic levels of the atom (say Na atom).

For a Na atom the single-outer-electron in the lowest ground state G is situated in the 3s orbital. Consequently, the energy level E_1 might designate the energy of the atom when this 'single electron' has been duly raised to the 3p state by virtue of its absorption of thermal, electrical or radiant energy. This phenomenon has been clearly shown with the help of the dotted-line in Figure : 24.1 (a). However, the atom ultimately gets back to its ground state, may be after 10^{-8} s, thereby emitting radiation whose frequency is given by the following expression :

$$\nu_1 = (E_1 - G)h$$

or

$$\lambda_1 = hc/(E_1 - G)$$

This particular phenomenon is depicted by the solid-line in Figure 24.1 (a). In the case of Na atom E_2 designates the highly energetic $4p$ state and the radiation λ_2 obtained therefrom will appear at a relatively shorter wavelength.

Figure 24.1 (b), represents the energy level diagram of a molecule where the energy differences among the various quantized vibrational and rotational states are comparatively much smaller as compared to the electronic states. The horizontal lines are due to the many excited vibrational states whereas the energy differences due to rotational states have not been shown in the said Figure. Thus, the multitude of various energy states is clearly shown by the solid lines in Figure 24.1 (b), whereby two distinct bands of radiation are obtained, each of which consists of a huge number of closely spaced lines.

- (d) **Effect of Concentration on Line and Band Spectra :** The radiant power by virtue of the radiant energy, of a line or band exclusively depends directly on the total number of excited atoms or molecules present, which is subsequently proportional to the total concentration of the species present in the source. Therefore, we may have the following expression :

$$P = kC$$

where, P = Radiant power,

C = Total concentration of the species, and

k = Constant of proportionality

The aforesaid relationship forms the basis of quantitative emission spectroscopy.

- (e) **Excitation-Energy Requirements :** A single spectral-line is emitted from an element only when the energy equivalent to the excitation potential of the element is usually absorbed. This particular requirement is very critical and important. Exactly in a similar manner, the full-fledged complete spectrum is obtained possibly only when the energy equivalent to the ionization potential is absorbed by a molecule.
- (f) **Limitations of Emission Spectroscopy :** The emission spectroscopy has a number of limitations that are enumerated below briefly :
- (1) Perhaps all the elements present in the periodic table might be excited to yield respective emission spectra by employing a huge energetic source. However, it has a serious drawback because most of the spectral lines invariably fall within the vacuum-ultraviolet region thereby rendering their critical studies rather difficult. Hence, the emission spectroscopy is exclusively limited to metals and metalloids. The non-metals, for instance : Phosphorus, Sulphur, Carbon etc. are not limited to these studies.
 - (2) **Emission spectroscopy of sodium *vis-a-vis* uranium :** Emission spectroscopy is mainly based on sensitivity which is inversely proportional to the complexity of the atomic spectra. In actual practice, it has been observed that the spectra of alkali-metals, like : K, Na, Li, Rb appear to be very simple and hence they may be studied conveniently without any difficulty. It is also pertinent to mention here that these spectra usually comprise of 13 to 14 adequately spaced lines having reasonably good sensitivity and possessing wavelengths.

In the specific case of sodium the resulting emission spectrum shall exhibit characteristic yellow lines. The spectrum is so highly sensitive that even the traces of Na show yellow lines distinctly.

In the case of other elements, for instance : Uranium, the emission spectrum normally displays thousands of narrowly spaced lines. However, the emission source possesses a fixed amount of energy which shall be spread up eventually amongst the thousands of lines thereby minimizing the sensitivity of each line. Hence, it is rather difficult to examine the less sensitive complex spectra of elements such as uranium.

24.3. INSTRUMENTATION

The various essential components of a reasonably good emission spectrograph are as follows, namely :

- (i) Excitation sources,
- (ii) Electrodes,
- (iii) Sample Handling,
- (iv) Monochromators,
- (v) Detectors, and
- (vi) Spectrographs.

24.3.1. EXCITATION SOURCES

The excitation sources may be sub divided into the following *two* heads, namely :

(a) **Salient Features of Excitation Sources** : These should fulfil the following procedural requirements :

- Sample should be changed into its vaporised form,
- Vaporised form of sample must be dissociated into atoms,
- Electrons present in the atoms should be excited from the ground state to higher-energy-levels,
- Capable of exciting atoms of most of the elements of interest (in the *Periodic Table*),
- To produce sufficient line-intensity in order to detect these lines within the scope of the ‘*detection limit*’, and
- Must essentially achieve reproducible excitation conditions of various samples.

(b) **Types of Excitation Sources** : The various types of excitation sources are as follows :

(i) **Flames** : A flame is generally employed for such molecules that do not need either very high temperatures for excitation or dissociation into atoms. Flames are comparatively inexpensive and cater for both stable and reproducible sources of excitation that can effectively handle a wide-range of typical analytical problems. However, the temperature of the flame is guided by a number of vital factors, such as :

- Types of Fuel and Oxidant,
- Fuel to Oxidant Ratio,
- Type of Burner Employed, and
- Zone (or region) in flame which is focussed into the entrance-slit of spectral-isolation-unit.

Table 24.1, records the temperatures of commonly used fuels and oxidants in flames in emission spectroscopy.

Table 24.1 : Temperatures of Commonly Used Fuels and Oxidants in Flames

S. No.	Type of		Temperature (°C)
	Fuel	Oxidant	
1.	Natural Gas	Oxygen	2700
2.	Natural Gas	Air	1700
3.	Acetylene	Oxygen	3200
4.	Acetylene	Air	2200
5.	Hydrogen	Oxygen	2800
6.	Acetylene	Nitrous Oxide	3400

Note : (1) The temperature of the flame and the composition of the flame afford a direct influence on interferences which may give rise to erroneous results,

(2) The dissociation of molecules and excitation of atoms usually occur at a specific temperature.

(ii) **Direct Current Arc :** It is considered to be one of the most versatile excitation modes used extensively for quantitative spectrochemical emission analysis. Figure 24.2 represents the different essential components of the circuit for a direct current arc

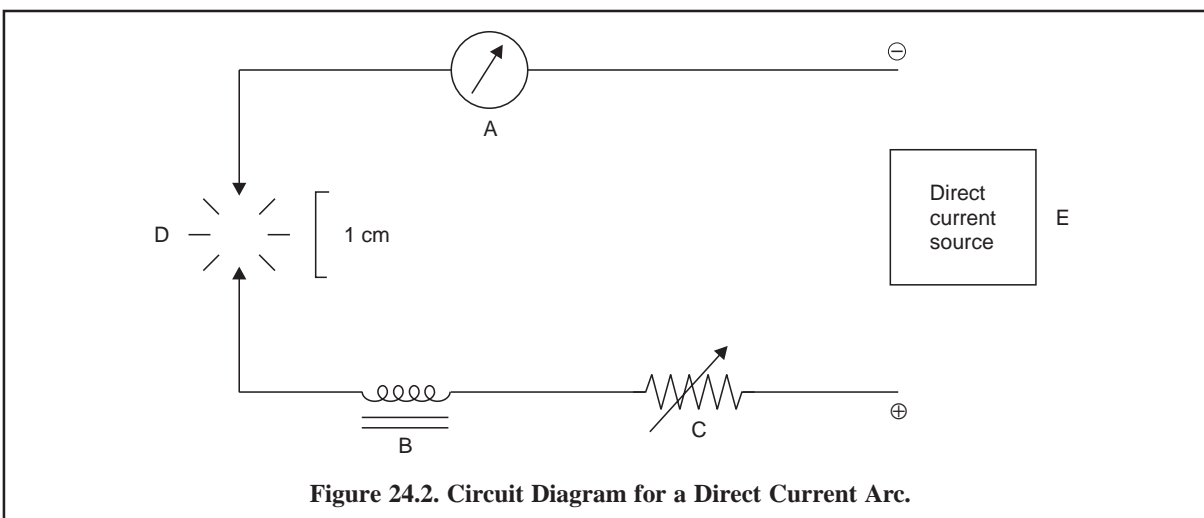

Figure 24.2. Circuit Diagram for a Direct Current Arc.

A = An Ammeter (Range 3 to 30 A),

B = Inductance Coil,

C = Variable Resistance (Range 10 to 40 Ω)

D = Arc Gap (Range from 20 mm to 1 cm), and

E = Direct Current Source (Range 110 to 220 V at 3 to 30 A).

Procedure : The various procedural steps are as follows :

- Current is passed across the arc-gap in series with the help of a variable resistor C (10 – 40 Ω) and an inductance coil B.
- Initial resistance caused due to air-gap is very high to allow conduction of current. Hence, the arc is first initiated by narrowing its gap momentarily while 110-220 V DC is applied. Once the current picks up flow, the temperature across the arc-gap shoots up promptly. The electrodes are pulled apart leaving a gap of 20 mm to 1 cm, thereby establishing the electric arc whose temperature varies from 4000 to 8000° K.
- Sample (solid or liquid) is usually introduced upon the lower electrode between the arc-gap, and
- Variable resistance (C) adjusts the intensity of current, whereas inductance coil (B) stabilizes its flow.

Merits of Direct-Current-Arc : They are as follows :

- Provides a very sensitive excitation source :
- Excitation energy is solely thermal and not electrical which is more than enough for exciting all the metal elements, and
- DC-arc gives rise to emission species that are exclusively neutral atoms rather than ions.

(iii) **Alternating Current Arc :** Figure 24.3 depicts the various essential components of the circuit diagram for an alternating current arc :

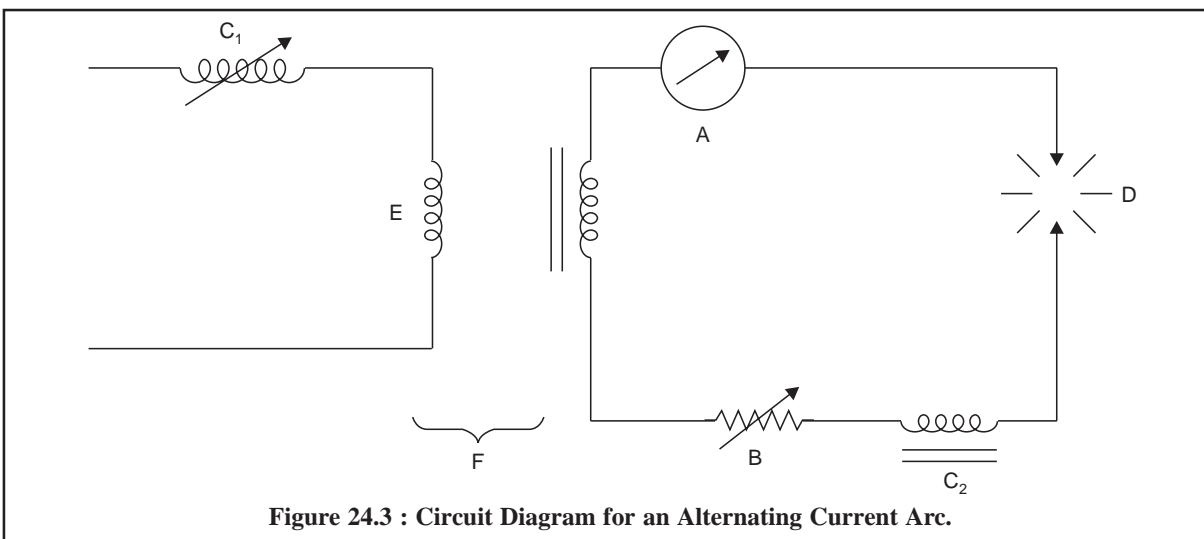

Figure 24.3 : Circuit Diagram for an Alternating Current Arc.

Where, A = Ammeter (Range 3 to 30 A)

B = Variable Resistance,

C_1 = Variable Inductance in the Primary Circuit,

C_2 = Inductance Coil in the Main Circuit,

D = Arc Gap (Range from 20 mm to 1 cm),

E = Primary Circuit, and

F = Step-up Transformer (Range 2000 to 5000 V).

Procedure : The procedural details are stated below :

- Step-up transformer (F) maintains a high voltage of 2000 to 5000 V, which helps the arc to jump the gap,
- Variable inductance (C_1) is adjusted duly to maintain a current of 1 to 5 A in the primary circuit,
- Current in the main circuit is alternating at a frequency of 60 Hz thereby extinguishing the arc 120 times in one second, and
- After each cycle the arc picks out a new surface area whereby the entire surface of the sample under examination, is exhaustively arced and subsequently excited.

It is worthwhile noting that the arc-gap temperature in this case is considerably lower than the direct-current arc, due to the stop-and start nature of the source, which ultimately offers a much lower sensitivity.

24.3.2. ELECTRODES

The electrodes normally employed in emission spectroscopy are of *two* types, namely :

(a) **Self Electrodes :** If the material (sample) under probe is itself not only a good conductor but also can tolerate very high temperatures (in the *arc-gap*), the material may be used as the electrode ; and such electrodes are termed as **self-electrodes**.

Examples : Pure metal powders may be compressed into solid discs or cylinders which can be used as electrodes. Likewise, the analyzing alloys can also be used.

(b) **Graphite Electrodes :** If the material (sample) under study is neither a good conductor nor can afford to tolerate high temperatures, it is usually kept in a small cavity of the lower graphite electrode whereas the upper electrode (graphite) is given a pointed sharp-shape. These electrodes have centre posts which minimises *wandering-of-the-arc source* thereby improving the reproducibility ; and their narrow neck improves the sensitivity appreciably.

24.3.3. SAMPLE HANDLING

Two types of samples are usually examined by emission spectroscopy, namely :

- (a) **Solids** : Solid samples can also be sub-divided into two categories, such as : (i) Those possessing good conductance characteristics and can withstand high temperatures : it can be achieved by making electrodes with the material directly to be used for the electrical discharge ; (ii) Those having poor conductance and cannot withstand high temperatures : it can be powdered mixed with the powdered graphite (known as buffer) and placed in the depression of the lower graphite electrode. On passing the electrical discharge the material (sample) is first vaporised into the body of the discharge and subsequently the spectrographic emission occurs.
- (b) **Liquids** : Liquid samples may be dispensed conveniently with the aid of two types of small-holders, namely : *firstly*, wherein the porous base of the cup gradually releases the sample into the discharge from the top ; and *secondly*, wherein the rotating-disc carriers take up the sample into the discharge from the bottom steadily.

Note : (1) Both types are found to be suitable for either aqueous or non-aqueous solvents, and

- (2) Samples dissolved in organic solvents usually ignite in the discharge which may produce erratic emission. It is more prominent in the rotating-disc type sample carriers.

24.3.4. MONOCHROMATORS

Monochromators help to isolate and separate the various lines of the sample's emission spectrum. Two types are generally used in the emission spectroscopy, namely :

- (a) **Prism Monochromators** : In usual practice, the materials of construction of prisms are either quartz or silica (fused) because of their absolute transparency to UV-radiation. Prism monochromators normally bring forth *two serious shortcomings* which are discussed briefly here, namely :

First, when light from a single emission-line (of one particular wavelength) is made to pass through a quartz (or glass) prism, it emerges from the other side of the prism as two different lines as shown in Figure 24.4 (a). This splitting-up of one line into two separate lines affords not only the loss of the emergent light's intensity but also complicates the interpretation of the spectrum ; thereby rendering its use both in qualitative and quantitative analysis rather difficult. Cornu Type Prisms eliminate this lacuna completely. In this case, two-half prisms are joined together : the first half-prism splits the incident emission line into two separate beams, whereas the second-half prism recombines them into a single emergent beam as shown in Figure 24.4 (b).

Secondly, the dispersion of a prism is never constant over a wide range of wavelength, whereby the identification of either the emission lines or the unknown wavelengths is rather difficult on the basis of simply measuring their dispersions.

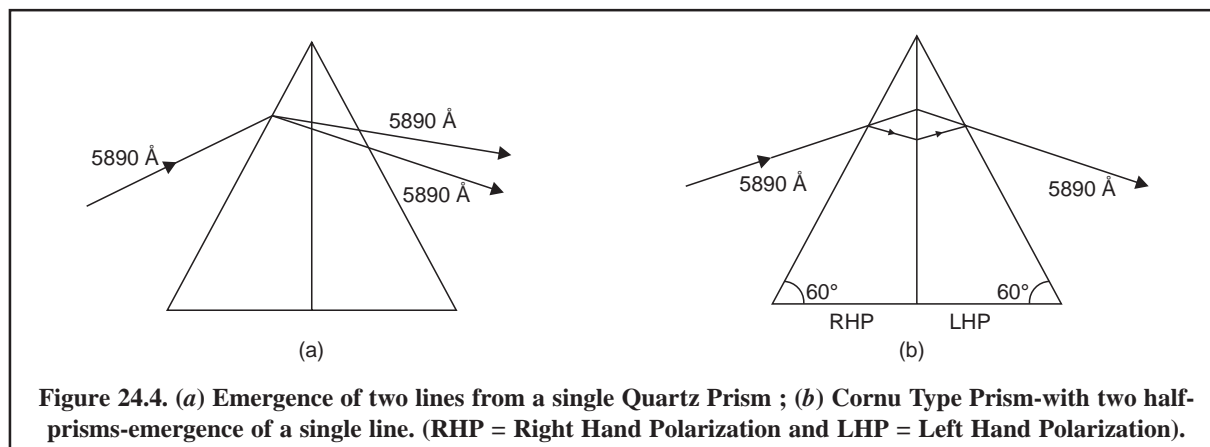

Figure 24.4. (a) Emergence of two lines from a single Quartz Prism ; (b) Cornu Type Prism-with two half-prisms-emergence of a single line. (RHP = Right Hand Polarization and LHP = Left Hand Polarization).

(b) **Grating Monochromators** : The various advantages of grating monochromators are as follows :

- **Much better resolution achieved** : thereby resulting in the development of many sophisticated equipments,
- **Offers absolute linear dispersion** : thereby replacing prisms completely as the dispersing element inspite of its high-cost, and
- **Resolution is constant and independent of wavelength** : thereby the identification of the wavelength of emission lines on a photographic plate is simplified *i.e.*, once a known reference line is identified, other lines may be known very conveniently.

Disadvantage : The major disadvantage of grating monochromators is that its higher-order-wavelengths overlap which may be eliminated completely either by using filters or by employing detectors that are not sensitive to the higher-orders.

24.3.5. DETECTORS

There are *two* types of detectors that are used most frequently in emission spectroscopy, namely :

- (a) **Photographic Detectors**-used for qualitative analysis, and
 (b) **Photomultiplier Detectors**-used for quantitative analysis.

The *two* detectors shall be discussed here briefly.

24.3.5.1. Photographic Detectors

Many spectrographs record the intensity of spectral lines on a photographic emulsion directly, which is subsequently developed by an appropriate '**developer**' in the prescribed duration at a specific recommended temperature.

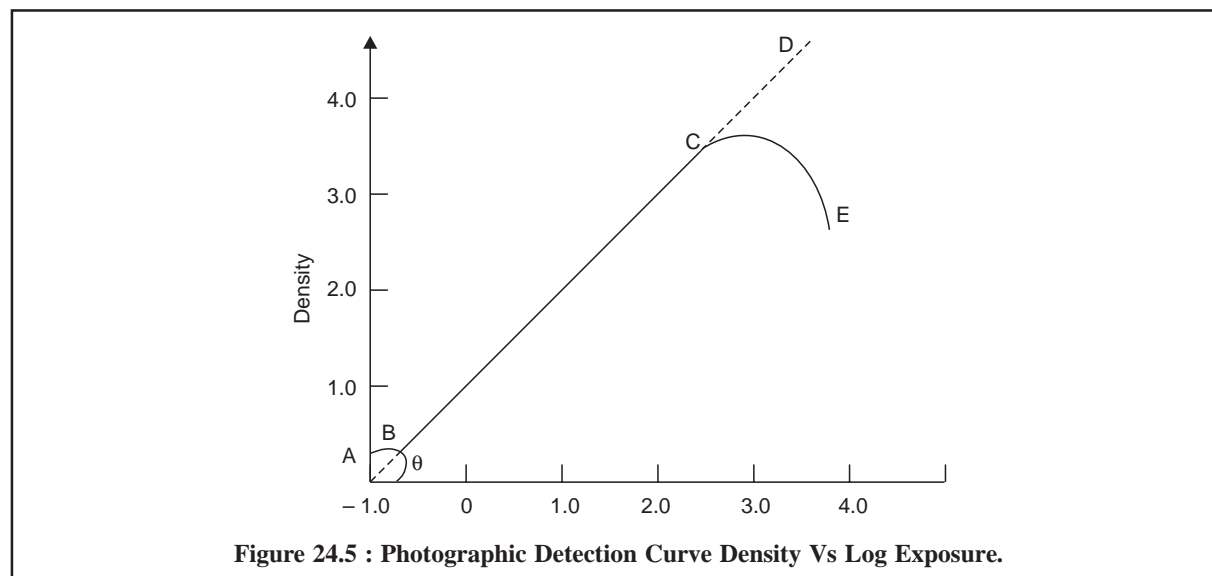

Procedure : The various steps involved are as follows :

1. A beam of light is passed through a clear zone of the film and subsequently the intensity of the transmitted beam is measured by means of a phototube fitted in the densitometer,
2. A beam of light is then passed through the darkened zone of the film and the intensity is measured as stated above,
3. The logarithm of the ratio of the intensity of the light transmitted through the clear zone and the darkened zone is computed ; and is plotted against the logarithm of the exposure as shown in Figure 24.5.

4. The region BC in Figure 24.5 clearly shows that the density is directly proportional to the logarithm of the intensity of the curve and represents the most useful zone of the curve, and
5. The slope of region BC is usually called as the 'gamma' (γ) of the emulsion of photographic plate and is expressed as :

$$\gamma = \tan \theta$$

Consequently, it may be inferred that when the value of γ is high, it is indicative of the fact that high-degree of contrast is expected ; and if γ has a low value, naturally low-degree of contrast is deemed for.

(b) **Photomultiplier Detectors** : Spectrographs that record the direct-reading emissions exclusively essentially make use of photomultiplier detectors instead of a photographic plate. It requires a large number of photomultiplier tubes for carrying out the detection of different emission lines simultaneously and that is way the direct-reading devices are relatively much costlier. By virtue of its convenience, fast and more accurate and precise results, this type of detectors is always preferred.

However, it is worthwhile to have a comparison of the merits and demerits of photographic and photomultiplier detectors side-by-side as follows :

Photographic Detector	Photomultiplier Detector
<p>Merits :</p> <ol style="list-style-type: none"> 1. Large number of spectral lines may be recorded at the same time. 2. Provides a permanent record of the spectrum that may be stored. 3. Emission intensity may be integrated by a photographic emulsion over a period of time. 4. Photographic emulsions have a very high degree of sensitivity throughout the visible and UV-regions. 5. Cost-effective detector. <p>Demerits :</p> <ol style="list-style-type: none"> 1. Requires controlled photographic development that involves a lot of time and enhances the risk of errors. 2. Does not display quick response to spectral lines. 3. Interpretation of spectral lines not so necessary. 	<p>It cannot be achieved.</p> <p>It is less versatile.</p> <p>It cannot be obtained.</p> <p>It is not so sensitive.</p> <p>Very costly detector.</p> <p>Does not require either controlled photographic development or have risk of error.</p> <p>It shows immediate response to spectral lines.</p> <p>Interpretation is easier and hence makes it the most desirable detectors.</p>

24.3.6. SPECTROGRAPHS

The resulting 'emission spectra' from the detector may be thoroughly studied with the aid of an effective optical arrangement which will critically identify the frequencies and their respective intensities. The optical arrangement varies from one instrument to another based on the device used, and hence the nomenclature also varies, namely :

S. No.	Nomenclature	Device Used	Measurement Performed
1.	Spectroscope	Visual	Frequencies
2.	Spectrograph	Photographic	Wavelengths (intensities)
3.	Spectrometer	Scanning a spectrum	Wavelengths (intensities)

However, the various commercially available spectrographs may be differentiated solely by the fact whether they make use of either a 'prism' or a 'grating' as the vital dispersing medium. A good 'spectrograph' using either a prism or a grating shall be discussed briefly here.

(a) Littrow Type Spectrograph (i.e., a Prism Instrument)

Figure 24.6, shows the schematic diagram of a **Littrow Type spectrograph** which essentially has the following components, namely :

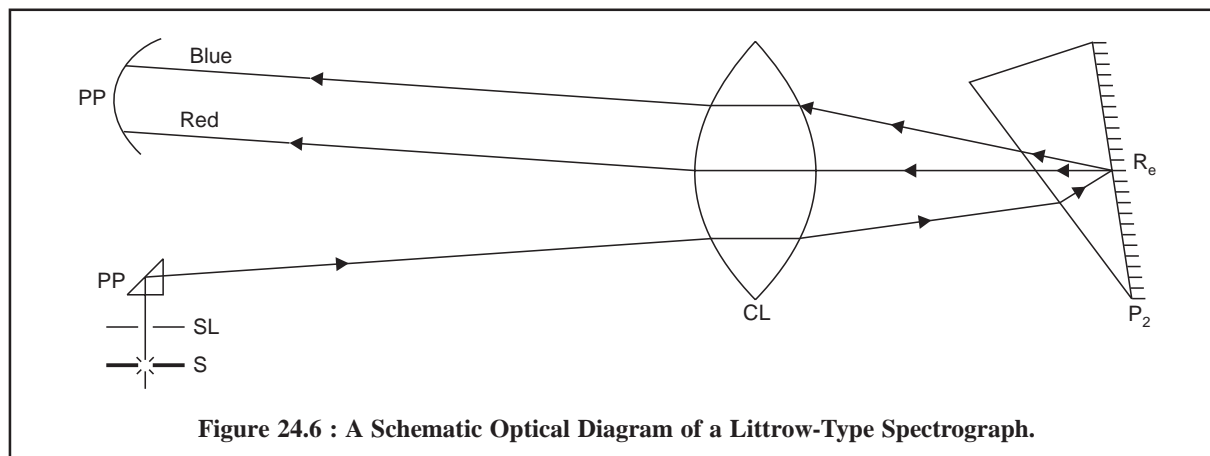

Figure 24.6 : A Schematic Optical Diagram of a Littrow-Type Spectrograph.

S = Excitation source,

SL = Slit,

P₁ = A reflecting prism,

CL = A collimating lens,

P₂ = Littrow prism,

RC = Reflective coating (mirrored surface), and

PP = Photographic plate.

A **Littrow type spectrograph** makes use of a Littrow-type prism exclusively which is made from a single piece of Quartz with its rear-surface mirrored or metallized (with Silver). This sort of prism completely eliminates the polarization effects as the beam of light moves back and forth through the body of the same prism. Thus, a beam of light from the source of light (S) passes through the slit (SL), gets reflected through the reflecting prism (P₁), penetrates through the collimating lens (CL), enters the Littrow prism (P₂), again gets reflected by its reflective coating (RC), enters the collimating lens (CL) and finally comes out as a spectrum that is recorded on the photographic plate (PP).

It is interesting to observe that a typical large Littrow Spectrograph having a single Quartz prism covers a wavelength range from 2000 to 80000 Å.

(b) Ebert-Mounting Spectrograph (i.e., a Grating Instrument)

An **Ebert-mounting spectrograph** exclusively makes use of a plane-grating rather than a concave-grating as employed either in *Rowland mounting* or in *Eagle arrangement*. It enormously helps as the ruling of the grating is a lot easier and less complicated. In this particular optical device a concave mirror (CM) is used to render the radiation striking the grating (G) parallel and also to focus the dispersed (-o-o-o-) radiation on the photographic plate of the camera.

Figure 24.7, depicts the schematic diagram of a **Ebert-Mounting Spectrograph** with the following vital components.

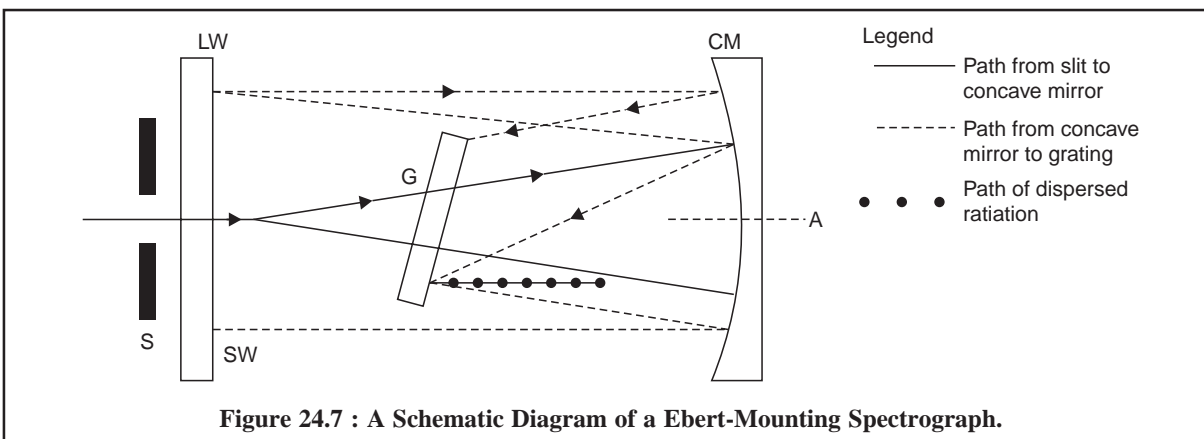

S = Slit,

G = Grating,

CM = Concave Mirror,

LW = Longer wavelength,

SW = Shorter wavelength, and

A = Axis.

Salient Features of Ebert-Mounting Spectrographs : The various salient features are, namely :

- Gratings normally have 600 to 120 lines per mm,
- Covers a wavelength range from 1800-30,000 Å,
- Possess the highest wavelength range, and
- Possible to observe high-order visible and UV-spectra.

24.4. APPLICATIONS OF EMISSION SPECTROSCOPY

In general, prepare not fewer than three reference solutions of the element to be determined covering the concentration range recommended by the manufacturers for the element and instrument used. Any reagent used in preparing the solution of the substance being examined must be added to the reference solution in the same concentration. Besides, where solids are present in solutions they may give rise to interferences and for that reason the solid content of the solutions must be below 2% wherever possible.

1. Emission spectroscopy has been employed for the analysis of various alloys, namely : aluminium, copper, magnesium, zinc, lead, and tin.
2. It has been used for the analysis of a number of elements, for instance : Na, K, Zn, Cu, Ca, Mg, Ni and Fe present in various tissues of human beings. Changes in trace-metal concentrations have been studied at length with regard to the ageing process.
3. Trace amounts of Ca, Cu, and Zn have been examined in blood samples.
4. Presence of Zn has been examined in the pancreas tissue.
5. To determine the extent of elements present in '**crude oil**' by virtue of the fact that some of these may poison the catalysts used in the cracking-process *e.g.*, V, Cu, Ni, and Fe.

THEORETICAL AND PRACTICAL EXERCISES

1. Discuss the fundamental theory of '**Emission Spectroscopy**'. Substantiate your explanation based on the energy-level diagrams for an 'atom' and a 'molecule'.
2. How would you explain the following cardinal aspects in Emission spectroscopy ?
 - (i) Effect of concentration on '**Line**' and '**Band**' spectra.
 - (ii) Limitations of Emission spectroscopy.
3. With the help of a neat-labeled circuit diagram explain the following :
 - (a) Direct Current Arc
 - (b) Alternating Current ArcDiscuss their procedural steps, merits/demerits explicitly.
4. Describe the two 'common detectors' invariably used in emission spectroscopy. Differentiate the plus and negative aspects encountered in : (a) Photographic Detector ; and (b) Photomultiplier Detector, briefly.
5. How would you identify the '**frequencies**' and the '**intensities**' of emission spectra by the help of :
 - (a) Littrow type spectrograph,
 - (b) Ebert-mounting spectrograph.Explain the working with a schematic diagram.
6. Enumerate the various applications of '**Emission Spectroscopy**' with respect to the following entities :
 - (i) analysis of alloy,
 - (ii) analysis of elements in tissues,
 - (iii) analysis of elements in blood samples,
 - (iv) analysis of Zn in pancreas tissue, and
 - (v) elements present in 'crude oil sample'.

RECOMMENDED READINGS

1. Kolthoff, I.M. and P.J. Elving., Eds. '**Treatise on Analytical Chemistry**' Part I, Volume 5, New York, Wiley, 1964.
2. Crooks, J.E., '**The Spectrum in Chemistry**', New York, Academic Press, 1978.
3. '**The International Pharmacopoeia**', Vol. I., **General Methods of Analysis**, Geneva, World Health Organization, 3rd., ed. 1979.
4. Hargis, H.G., '**Analytical chemistry**', New Jersey, Prentice Hall, 1988.