

## CHAPTER

# 2



# Generating Stations

- 2.1 Generating Stations
- 2.2 Steam Power Station (Thermal Station)
- 2.3 Schematic Arrangement of Steam Power Station
- 2.4 Choice of Site for Steam Power Stations
- 2.5 Efficiency of Steam Power Station
- 2.6 Equipment of Steam Power Station
- 2.7 Hydro-electric Power Station
- 2.8 Schematic Arrangement of Hydro-electric Power Station
- 2.9 Choice of Site for Hydro-electric Power Stations
- 2.10 Constituents of Hydro-electric Plant
- 2.11 Diesel Power Station
- 2.12 Schematic Arrangement of Diesel Power Station
- 2.13 Nuclear Power Station
- 2.14 Schematic Arrangement of Nuclear Power Station
- 2.15 Selection of Site for Nuclear Power Station
- 2.16 Gas Turbine Power Plant
- 2.17 Schematic Arrangement of Gas Turbine Power Plant
- 2.18 Comparison of the Various Power Plants

## Introduction

In this modern world, the dependence on electricity is so much that it has become a part and parcel of our life. The ever increasing use of electric power for domestic, commercial and industrial purposes necessitates to provide bulk electric power economically. This is achieved with the help of suitable power producing units, known as *Power plants or Electric power generating stations*. The design of a power plant should incorporate two important aspects. Firstly, the selection and placing of necessary power-generating equipment should be such so that a maximum of return will result from a minimum of expenditure over the working life of the plant. Secondly, the operation of the plant should be such so as to provide cheap, reliable and continuous service. In this chapter, we shall focus our attention on various types of generating stations with special reference to their advantages and disadvantages.

## 2.1 Generating Stations

*Bulk electric power is produced by special plants known as **generating stations** or **power plants**.*

A generating station essentially employs a

prime mover coupled to an alternator for the production of electric power. The prime mover (*e.g.*, steam turbine, water turbine etc.) converts energy from some other form into mechanical energy. The alternator converts mechanical energy of the prime mover into electrical energy. The electrical energy produced by the generating station is transmitted and distributed with the help of conductors to various consumers. It may be emphasised here that apart from prime mover-alternator combination, a modern generating station employs several auxiliary equipment and instruments to ensure cheap, reliable and continuous service.

Depending upon the form of energy converted into electrical energy, the generating stations are classified as under :

- |                             |                                   |
|-----------------------------|-----------------------------------|
| (i) Steam power stations    | (ii) Hydroelectric power stations |
| (iii) Diesel power stations | (iv) Nuclear power stations       |

## 2.2 Steam Power Station (Thermal Station)

A generating station which converts heat energy of coal combustion into electrical energy is known as a **steam power station**.

A steam power station basically works on the Rankine cycle. Steam is produced in the boiler by utilising the heat of coal combustion. The steam is then expanded in the prime mover (*i.e.*, steam turbine) and is condensed in a condenser to be fed into the boiler again. The steam turbine drives the alternator which converts mechanical energy of the turbine into electrical energy. This type of power station is suitable where coal and water are available in abundance and a large amount of electric power is to be generated.

### Advantages

- (i) The fuel (*i.e.*, coal) used is quite cheap.
- (ii) Less initial cost as compared to other generating stations.
- (iii) It can be installed at any place irrespective of the existence of coal. The coal can be transported to the site of the plant by rail or road.
- (iv) It requires less space as compared to the hydroelectric power station.
- (v) The cost of generation is lesser than that of the diesel power station.

### Disadvantages

- (i) It pollutes the atmosphere due to the production of large amount of smoke and fumes.
- (ii) It is costlier in running cost as compared to hydroelectric plant.

## 2.3 Schematic Arrangement of Steam Power Station

Although steam power station simply involves the conversion of heat of coal combustion into electrical energy, yet it embraces many arrangements for proper working and efficiency. The schematic arrangement of a modern steam power station is shown in Fig. 2.1. The whole arrangement can be divided into the following stages for the sake of simplicity :

- |                                      |                           |
|--------------------------------------|---------------------------|
| 1. Coal and ash handling arrangement | 2. Steam generating plant |
| 3. Steam turbine                     | 4. Alternator             |
| 5. Feed water                        | 6. Cooling arrangement    |

**1. Coal and ash handling plant.** The coal is transported to the power station by road or rail and is stored in the coal storage plant. Storage of coal is primarily a matter of protection against coal strikes, failure of transportation system and general coal shortages. From the coal storage plant, coal is delivered to the coal handling plant where it is pulverised (*i.e.*, crushed into small pieces) in order to increase its surface exposure, thus promoting rapid combustion without using large quantity of

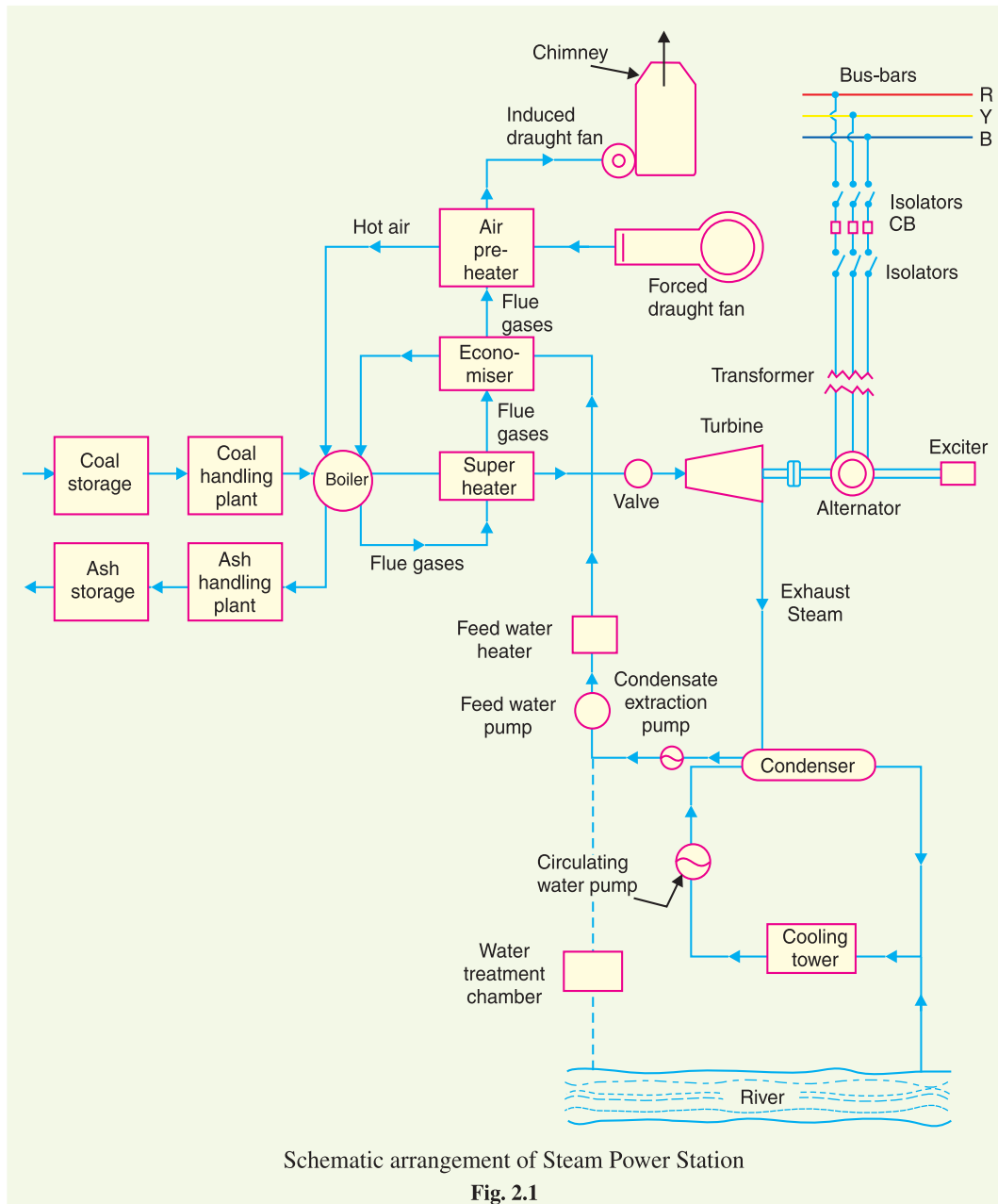

Schematic arrangement of Steam Power Station

Fig. 2.1

excess air. The pulverised coal is fed to the boiler by belt conveyors. The coal is burnt in the boiler and the ash produced after the complete combustion of coal is removed to the ash handling plant and then delivered to the ash storage plant for disposal. The removal of the ash from the boiler furnace is necessary for proper burning of coal.

It is worthwhile to give a passing reference to the amount of coal burnt and ash produced in a modern thermal power station. A 100 MW station operating at 50% load factor may burn about 20,000 tons of coal per month and ash produced may be to the tune of 10% to 15% of coal fired *i.e.*, 2,000 to 3,000 tons. In fact, in a thermal station, about 50% to 60% of the total operating cost consists of fuel purchasing and its handling.

**2. Steam generating plant.** The steam generating plant consists of a boiler for the production of steam and other auxiliary equipment for the utilisation of flue gases.

(i) **Boiler.** The heat of combustion of coal in the boiler is utilised to convert water into steam at high temperature and pressure. The flue gases from the boiler make their journey through superheater, economiser, air pre-heater and are finally exhausted to atmosphere through the chimney.

(ii) **Superheater.** The steam produced in the boiler is wet and is passed through a superheater where it is dried and superheated (*i.e.*, steam temperature increased above that of boiling point of water) by the flue gases on their way to chimney. Superheating provides two principal benefits. Firstly, the overall efficiency is increased. Secondly, too much condensation in the last stages of turbine (which would cause blade corrosion) is avoided. The superheated steam from the superheater is fed to steam turbine through the main valve.

(iii) **Economiser.** An economiser is essentially a feed water heater and derives heat from the flue gases for this purpose. The feed water is fed to the economiser before supplying to the boiler. The economiser extracts a part of heat of flue gases to increase the feed water temperature.

(iv) **Air preheater.** An air preheater increases the temperature of the air supplied for coal burning by deriving heat from flue gases. Air is drawn from the atmosphere by a forced draught fan and is passed through air preheater before supplying to the boiler furnace. The air preheater extracts heat from flue gases and increases the temperature of air used for coal combustion. The principal benefits of preheating the air are : increased thermal efficiency and increased steam capacity per square metre of boiler surface.

**3. Steam turbine.** The dry and superheated steam from the superheater is fed to the steam turbine through main valve. The heat energy of steam when passing over the blades of turbine is converted into mechanical energy. After giving heat energy to the turbine, the steam is exhausted to the *condenser* which condenses the exhausted steam by means of cold water circulation.

**4. Alternator.** The steam turbine is coupled to an alternator. The alternator converts mechanical energy of turbine into electrical energy. The electrical output from the alternator is delivered to the bus bars through transformer, circuit breakers and isolators.

**5. Feed water.** The condensate from the condenser is used as feed water to the boiler. Some water may be lost in the cycle which is suitably made up from external source. The feed water on its way to the boiler is heated by water heaters and economiser. This helps in raising the overall efficiency of the plant.

**6. Cooling arrangement.** In order to improve the efficiency of the plant, the steam exhausted from the turbine is condensed\* by means of a condenser. Water is drawn from a natural source of supply such as a river, canal or lake and is circulated through the condenser. The circulating water takes up the heat of the exhausted steam and itself becomes hot. This hot water coming out from the condenser is discharged at a suitable location down the river. In case the availability of water from the source of supply is not assured throughout the year, *cooling towers* are used. During the scarcity of water in the river, hot water from the condenser is passed on to the cooling towers where it is cooled. The cold water from the cooling tower is reused in the condenser.

## 2.4 Choice of Site for Steam Power Stations

In order to achieve overall economy, the following points should be considered while selecting a site for a steam power station :

(i) **Supply of fuel.** The steam power station should be located near the coal mines so that transportation cost of fuel is minimum. However, if such a plant is to be installed at a place

---

\* Efficiency of the plant is increased by reducing turbine exhaust pressure. Low pressure at the exhaust can be achieved by condensing the steam at the turbine exhaust.

where coal is not available, then care should be taken that adequate facilities exist for the transportation of coal.

- (ii) **Availability of water.** As huge amount of water is required for the condenser, therefore, such a plant should be located at the bank of a river or near a canal to ensure the continuous supply of water.
- (iii) **Transportation facilities.** A modern steam power station often requires the transportation of material and machinery. Therefore, adequate transportation facilities must exist *i.e.*, the plant should be well connected to other parts of the country by rail, road. etc.
- (iv) **Cost and type of land.** The steam power station should be located at a place where land is cheap and further extension, if necessary, is possible. Moreover, the bearing capacity of the ground should be adequate so that heavy equipment could be installed.
- (v) **Nearness to load centres.** In order to reduce the transmission cost, the plant should be located near the centre of the load. This is particularly important if *d.c.* supply system is adopted. However, if *a.c.* supply system is adopted, this factor becomes relatively less important. It is because *a.c.* power can be transmitted at high voltages with consequent reduced transmission cost. Therefore, it is possible to install the plant away from the load centres, provided other conditions are favourable.
- (vi) **Distance from populated area.** As huge amount of coal is burnt in a steam power station, therefore, smoke and fumes pollute the surrounding area. This necessitates that the plant should be located at a considerable distance from the populated areas.

**Conclusion.** It is clear that all the above factors cannot be favourable at one place. However, keeping in view the fact that now-a-days the supply system is *a.c.* and more importance is being given to generation than transmission, a site away from the towns may be selected. In particular, a site by river side where sufficient water is available, no pollution of atmosphere occurs and fuel can be transported economically, may perhaps be an ideal choice.

## 2.5 Efficiency of Steam Power Station

The overall efficiency of a steam power station is quite low (about 29%) due mainly to two reasons. Firstly, a huge amount of heat is lost in the condenser and secondly heat losses occur at various stages of the plant. The heat lost in the condenser cannot be avoided. It is because heat energy cannot be converted into mechanical energy without temperature difference. The greater the temperature difference, the greater is the heat energy converted\* into mechanical energy. This necessitates to keep the steam in the condenser at the lowest temperature. But we know that greater the temperature difference, greater is the amount of heat lost. This explains for the low efficiency of such plants.

(i) **Thermal efficiency.** The ratio of heat equivalent of mechanical energy transmitted to the turbine shaft to the heat of combustion of coal is known as **thermal efficiency** of steam power station.

$$\text{Thermal efficiency, } \eta_{\text{thermal}} = \frac{\text{Heat equivalent of mech. energy transmitted to turbine shaft}}{\text{Heat of coal combustion}}$$

The thermal efficiency of a modern steam power station is about 30%. It means that if 100 calories of heat is supplied by coal combustion, then mechanical energy equivalent of 30 calories will be available at the turbine shaft and rest is lost. It may be important to note that more than 50% of total heat of combustion is lost in the condenser. The other heat losses occur in flue gases, radiation, ash etc.

(ii) **Overall efficiency.** The ratio of heat equivalent of electrical output to the heat of combustion of coal is known as **overall efficiency** of steam power station *i.e.*

\* Thermodynamic laws.

$$\text{Overall efficiency, } \eta_{\text{overall}} = \frac{\text{Heat equivalent of electrical output}}{\text{Heat of combustion of coal}}$$

The overall efficiency of a steam power station is about 29%. It may be seen that overall efficiency is less than the thermal efficiency. This is expected since some losses (about 1%) occur in the alternator. The following relation exists among the various efficiencies.

$$\text{Overall efficiency} = \text{Thermal efficiency} \times \text{Electrical efficiency}$$

## 2.6 Equipment of Steam Power Station

A modern steam power station is highly complex and has numerous equipment and auxiliaries. However, the most important constituents of a steam power station are :

1. Steam generating equipment
2. Condenser
3. Prime mover
4. Water treatment plant
5. Electrical equipment.

**1. Steam generating equipment.** This is an important part of steam power station. It is concerned with the generation of superheated steam and includes such items as boiler, boiler furnace, superheater, economiser, air pre-heater and other heat reclaiming devices.

(i) **Boiler.** A boiler is closed vessel in which water is converted into steam by utilising the heat of coal combustion. Steam boilers are broadly classified into the following two types :

- (a) Water tube boilers
- (b) Fire tube boilers

In a water tube boiler, water flows through the tubes and the hot gases of combustion flow over these tubes. On the other hand, in a fire tube boiler, the hot products of combustion pass through the tubes surrounded by water. Water tube boilers have a number of advantages over fire tube boilers *viz.*, require less space, smaller size of tubes and drum, high working pressure due to small drum, less liable to explosion etc. Therefore, the use of water tube boilers has become universal in large capacity steam power stations.

(ii) **Boiler furnace.** A boiler furnace is a chamber in which fuel is burnt to liberate the heat energy. In addition, it provides support and enclosure for the combustion equipment *i.e.*, burners. The boiler furnace walls are made of refractory materials such as fire clay, silica, kaolin etc. These materials have the property to resist change of shape, weight or physical properties at high temperatures. There are following three types of construction of furnace walls :

- (a) Plain refractory walls
- (b) Hollow refractory walls with an arrangement for air cooling
- (c) Water walls.

The plain refractory walls are suitable for small plants where the furnace temperature may not be high. However, in large plants, the furnace temperature is quite high\* and consequently, the refractory material may get damaged. In such cases, refractory walls are made hollow and air is circulated through hollow space to keep the temperature of the furnace walls low. The recent development is to use water walls. These consist of plain tubes arranged side by side and on the inner face of the refractory walls. The tubes are connected to the upper and lower headers of the boiler. The boiler water is made to circulate through these tubes. The water walls absorb the radiant heat in the furnace which would otherwise heat up the furnace walls.

(iii) **Superheater.** A superheater is a device which superheats the steam *i.e.*, it raises the temperature of steam above boiling point of water. This increases the overall efficiency of the plant. A superheater consists of a group of tubes made of special alloy steels such as chromium-molybdenum. These tubes are heated by the heat of flue gases during their journey from the furnace to the chimney.

\* The size of furnace has to be limited due to space, cost and other considerations. This means that furnace of a large plant should develop more kilocalories per square metre of furnace which implies high furnace temperature.



The steam produced in the boiler is led through the superheater where it is superheated by the heat of flue gases. Superheaters are mainly classified into two types according to the system of heat transfer from flue gases to steam *viz.*

- (a) Radiant superheater                      (b) Convection superheater

The radiant superheater is placed in the furnace between the water walls and receives heat from the burning fuel through radiation process. It has two main disadvantages. Firstly, due to high furnace temperature, it may get overheated and, therefore, requires a careful design. Secondly, the temperature of superheater falls with increase in steam output. Due to these limitations, radiant superheater is not finding favour these days. On the other hand, a convection superheater is placed in the boiler tube bank and receives heat from flue gases entirely through the convection process. It has the advantage that temperature of superheater increases with the increase in steam output. For this reason, this type of superheater is commonly used these days.

(iv) **Economiser.** It is a device which heats the feed water on its way to boiler by deriving heat from the flue gases. This results in raising boiler efficiency, saving in fuel and reduced stresses in the boiler due to higher temperature of feed water. An economiser consists of a large number of closely spaced parallel steel tubes connected by headers or drums. The feed water flows through these tubes and the flue gases flow outside. A part of the heat of flue gases is transferred to feed water, thus raising the temperature of the latter.

(v) **Air Pre-heater.** Superheaters and economisers generally cannot fully extract the heat from flue gases. Therefore, pre-heaters are employed which recover some of the heat in the escaping gases. The function of an air pre-heater is to extract heat from the flue gases and give it to the air being supplied to furnace for coal combustion. This raises the furnace temperature and increases the thermal efficiency of the plant. Depending upon the method of transfer of heat from flue gases to air, air pre-heaters are divided into the following two classes :

- (a) Recuperative type                      (b) Regenerative type

The recuperative type air-heater consists of a group of steel tubes. The flue gases are passed through the tubes while the air flows externally to the tubes. Thus heat of flue gases is transferred to air. The regenerative type air pre-heater consists of slowly moving drum made of corrugated metal plates. The flue gases flow continuously on one side of the drum and air on the other side. This action permits the transference of heat of flue gases to the air being supplied to the furnace for coal combustion.

**2. Condensers.** A condenser is a device which condenses the steam at the exhaust of turbine. It serves two important functions. Firstly, it creates a very low \*pressure at the exhaust of turbine, thus permitting expansion of the steam in the prime mover to a very low pressure. This helps in converting heat energy of steam into mechanical energy in the prime mover. Secondly, the condensed steam can be used as feed water to the boiler. There are two types of condensers, namely :

- (i) Jet condenser                              (ii) Surface condenser

In a jet condenser, cooling water and exhausted steam are mixed together. Therefore, the temperature of cooling water and condensate is the same when leaving the condenser. Advantages of this type of condenser are : low initial cost, less floor area required, less cooling water required and low maintenance charges. However, its disadvantages are : condensate is wasted and high power is required for pumping water.

In a surface condenser, there is no direct contact between cooling water and exhausted steam. It consists of a bank of horizontal tubes enclosed in a cast iron shell. The cooling water flows through the tubes and exhausted steam over the surface of the tubes. The steam gives up its heat to water and is itself condensed. Advantages of this type of condenser are : condensate can be used as feed water, less pumping power required and creation of better vacuum at the turbine exhaust. However, disad-

\* By liquidating steam at the exhaust of turbine, a region of emptiness is created. This results in a very low pressure at the exhaust of turbine.

vantages of this type of condenser are : high initial cost, requires large floor area and high maintenance charges.

**3. Prime movers.** The prime mover converts steam energy into mechanical energy. There are two types of steam prime movers *viz.*, steam engines and steam turbines. A steam turbine has several advantages over a steam engine as a prime mover *viz.*, high efficiency, simple construction, higher speed, less floor area requirement and low maintenance cost. Therefore, all modern steam power stations employ steam turbines as prime movers.

Steam turbines are generally classified into two types according to the action of steam on moving blades *viz.*

- (i) Impulse turbines
- (ii) Reaction turbines

In an impulse turbine, the steam expands completely in the stationary nozzles (or fixed blades), the pressure over the moving blades remaining constant. In doing so, the steam attains a high velocity and impinges against the moving blades. This results in the impulsive force on the moving blades which sets the rotor rotating. In a reaction turbine, the steam is partially expanded in the stationary nozzles, the remaining expansion takes place during its flow over the moving blades. The result is that the momentum of the steam causes a reaction force on the moving blades which sets the rotor in motion.

**4. Water treatment plant.** Boilers require clean and soft water for longer life and better efficiency. However, the source of boiler feed water is generally a river or lake which may contain suspended and dissolved impurities, dissolved gases etc. Therefore, it is very important that water is first purified and softened by chemical treatment and then delivered to the boiler.

The water from the source of supply is stored in storage tanks. The suspended impurities are removed through sedimentation, coagulation and filtration. Dissolved gases are removed by aeration and degasification. The water is then '*softened*' by removing temporary and permanent hardness through different chemical processes. The pure and soft water thus available is fed to the boiler for steam generation.

**5. Electrical equipment.** A modern power station contains numerous electrical equipment. However, the most important items are :

- (i) **Alternators.** Each alternator is coupled to a steam turbine and converts mechanical energy of the turbine into electrical energy. The alternator may be hydrogen or air cooled. The necessary excitation is provided by means of main and pilot exciters directly coupled to the alternator shaft.
- (ii) **Transformers.** A generating station has different types of transformers, *viz.*,
  - (a) main step-up transformers which step-up the generation voltage for transmission of power.
  - (b) station transformers which are used for general service (*e.g.*, lighting) in the power station.
  - (c) auxiliary transformers which supply to individual unit-auxiliaries.
- (iii) **Switchgear.** It houses such equipment which locates the fault on the system and isolate the faulty part from the healthy section. It contains circuit breakers, relays, switches and other control devices.

**Example 2.1.** A steam power station has an overall efficiency of 20% and 0.6 kg of coal is burnt per kWh of electrical energy generated. Calculate the calorific value of fuel.



**Solution.**

Let  $x$  kcal/kg be the calorific value of fuel.

Heat produced by 0.6 kg of coal =  $0.6x$  kcal

Heat equivalent of 1 kWh = 860 kcal

$$\text{Now, } \eta_{\text{overall}} = \frac{\text{Electrical output in heat units}}{\text{Heat of combustion}}$$

$$\text{or } 0.2 = \frac{860}{0.6x}$$

$$\therefore x = \frac{860}{0.6 \times 0.2} = \mathbf{7166.67 \text{ kcal/kg}}$$

**Example 2.2.** A thermal station has the following data :

Max. demand	= 20,000 kW	;	Load factor	= 40%
Boiler efficiency	= 85%	;	Turbine efficiency	= 90%
Coal consumption	= 0.9 kg/kWh	;	Cost of 1 ton of coal	= Rs. 300

Determine (i) thermal efficiency and (ii) coal bill per annum.

**Solution.**

(i) Thermal efficiency =  $\eta_{\text{boiler}} \times \eta_{\text{turbine}} = 0.85 \times 0.9 = \mathbf{0.765}$  or **76.5 %**

(ii) Units generated/annum = Max. demand  $\times$  L.F.  $\times$  Hours in a year  
 =  $20,000 \times 0.4 \times 8760 = 7008 \times 10^4$  kWh

$$\text{Coal consumption/annum} = \frac{(0.9)(7008 \times 10^4)}{1000} = 63,072 \text{ tons}$$

$\therefore$  Annual coal bill = Rs 300  $\times$  63072 = **Rs 1,89,21,600**

**Example 2.3.** A steam power station spends Rs. 30 lakhs per annum for coal used in the station. The coal has a calorific value of 5000 kcal/kg and costs Rs. 300 per ton. If the station has thermal efficiency of 33% and electrical efficiency of 90%, find the average load on the station.

**Solution.**

$$\text{Overall efficiency, } \eta_{\text{overall}} = 0.33 \times 0.9 = 0.297$$

$$\text{Coal used/annum} = 30 \times 10^5 / 300 = 10^4 \text{ tons} = 10^7 \text{ kg}$$

$$\begin{aligned} \text{Heat of combustion} &= \text{Coal used/annum} \times \text{Calorific value} \\ &= 10^7 \times 5000 = 5 \times 10^{10} \text{ kcal} \end{aligned}$$

$$\begin{aligned} \text{Heat output} &= \eta_{\text{overall}} \times \text{Heat of combustion} \\ &= (0.297) \times (5 \times 10^{10}) = 1485 \times 10^7 \text{ kcal} \end{aligned}$$

$$\text{Units generated/annum} = 1485 \times 10^7 / 860 \text{ kWh}$$

$$\therefore \text{Average load on station} = \frac{\text{Units generated / annum}}{\text{Hours in a year}} = \frac{1485 \times 10^7}{860 \times 8760} = \mathbf{1971 \text{ kW}}$$

**Example 2.4.** The relation between water evaporated ( $W$  kg), coal consumption ( $C$  kg) and kWh generated per 8-hour shift for a steam generating station is as follows :

$$W = 13500 + 7.5 \text{ kWh} \quad \dots(i)$$

$$C = 5000 + 2.9 \text{ kWh} \quad \dots(ii)$$

(i) To what limiting value does the water evaporating per kg of coal consumed approach as the station output increases ? (ii) How much coal per hour would be required to keep the station running on no load ?

**Solution.**

(i) For an 8-hour shift, weight of water evaporated per kg of coal consumed is

$$\frac{W}{C} = \frac{13500 + 7.5 \text{ kWh}}{5000 + 2.9 \text{ kWh}}$$

As the station output (*i.e.*, kWh) increases towards infinity, the limiting value of  $W/C$  approaches  $7.5/2.9 = 2.6$ . Therefore, the weight of water evaporated per kg of coal consumed approaches a limiting value of **2.6 kg** as the kWh output increases.

(ii) At no load, the station output is zero *i.e.*, kWh = 0. Therefore, from expression (ii), we get, coal consumption at no load

$$= 5000 + 2.9 \times 0 = 5000 \text{ kg}$$

$$\therefore \text{Coal consumption/hour} = 5000/8 = \mathbf{625 \text{ kg}}$$

**Example 2.5.** A 100 MW steam station uses coal of calorific value 6400 kcal/kg. Thermal efficiency of the station is 30% and electrical efficiency is 92%. Calculate the coal consumption per hour when the station is delivering its full rated output.

**Solution.**

Overall efficiency of the power station is

$$\eta_{\text{overall}} = \eta_{\text{thermal}} \times \eta_{\text{elect}} = 0.30 \times 0.92 = 0.276$$

$$\text{Units generated/hour} = (100 \times 10^3) \times 1 = 10^5 \text{ kWh}$$

$$\text{Heat produced/hour, } H = \frac{\text{Electrical output in heat units}}{\eta_{\text{overall}}}$$

$$= \frac{10^5 \times 860}{0.276} = 311.6 \times 10^6 \text{ kcal} \quad (\because 1 \text{ kWh} = 860 \text{ kcal})$$

$$\therefore \text{Coal consumption/hour} = \frac{H}{\text{Calorific value}} = \frac{311.6 \times 10^6}{6400} = \mathbf{48687 \text{ kg}}$$

### TUTORIAL PROBLEMS

1. A generating station has an overall efficiency of 15% and 0.75 kg of coal is burnt per kWh by the station. Determine the calorific value of coal in kilocalories per kilogram. **[7644 kcal/kg]**
2. A 75 MW steam power station uses coal of calorific value of 6400 kcal/kg. Thermal efficiency of the station is 30% while electrical efficiency is 80%. Calculate the coal consumption per hour when the station is delivering its full output. **[42 tons]**
3. A 65,000 kW steam power station uses coal of calorific value 15,000 kcal per kg. If the coal consumption per kWh is 0.5 kg and the load factor of the station is 40%, calculate (i) the overall efficiency (ii) coal consumption per day. **[(i) 28.7% (ii) 312 tons]**
4. A 60 MW steam power station has a thermal efficiency of 30%. If the coal burnt has a calorific value of 6950 kcal/kg, calculate :  
(i) the coal consumption per kWh,  
(ii) the coal consumption per day. **[(i) 0.413 kg (ii) 238 tons]**
5. A 25 MVA turbo-alternator is working on full load at a power factor of 0.8 and efficiency of 97%. Find the quantity of cooling air required per minute at full load, assuming that 90% of the total losses are dissipated by the internally circulating air. The inlet air temperature is 20° C and the temperature rise is 30° C. Given that specific heat of air is 0.24 and that 1 kg of air occupies 0.8 m<sup>3</sup>. **[890 m<sup>3</sup>/minute]**
6. A thermal station has an efficiency of 15% and 1.0 kg of coal burnt for every kWh generated. Determine the calorific value of coal. **[5733 kcal/kg]**

## 2.7 Hydro-electric Power Station

A generating station which utilises the potential energy of water at a high level for the generation of electrical energy is known as a **hydro-electric power station**.

Hydro-electric power stations are generally located in hilly areas where dams can be built conveniently and large water reservoirs can be obtained. In a hydro-electric power station, water head is created by constructing a dam across a river or lake. From the dam, water is led to a water turbine. The water turbine captures the energy in the falling water and changes the hydraulic energy (*i.e.*, product of head and flow of water) into mechanical energy at the turbine shaft. The turbine drives the alternator which converts mechanical energy into electrical energy. Hydro-electric power stations are becoming very popular because the reserves of fuels (*i.e.*, coal and oil) are depleting day by day. They have the added importance for flood control, storage of water for irrigation and water for drinking purposes.

### Advantages

- (i) It requires no fuel as water is used for the generation of electrical energy.
- (ii) It is quite neat and clean as no smoke or ash is produced.
- (iii) It requires very small running charges because water is the source of energy which is available free of cost.
- (iv) It is comparatively simple in construction and requires less maintenance.
- (v) It does not require a long starting time like a steam power station. In fact, such plants can be put into service instantly.
- (vi) It is robust and has a longer life.
- (vii) Such plants serve many purposes. In addition to the generation of electrical energy, they also help in irrigation and controlling floods.
- (viii) Although such plants require the attention of highly skilled persons at the time of construction, yet for operation, a few experienced persons may do the job well.

### Disadvantages

- (i) It involves high capital cost due to construction of dam.
- (ii) There is uncertainty about the availability of huge amount of water due to dependence on weather conditions.
- (iii) Skilled and experienced hands are required to build the plant.
- (iv) It requires high cost of transmission lines as the plant is located in hilly areas which are quite away from the consumers.

## 2.8 Schematic Arrangement of Hydro-electric Power Station

Although a hydro-electric power station simply involves the conversion of hydraulic energy into electrical energy, yet it embraces many arrangements for proper working and efficiency. The schematic arrangement of a modern hydro-electric plant is shown in Fig. 2.2.

The dam is constructed across a river or lake and water from the catchment area collects at the back of the dam to form a reservoir. A pressure tunnel is taken off from the reservoir and water brought to the valve house at the start of the penstock. The valve house contains main sluice valves and automatic isolating valves. The former controls the water flow to the power house and the latter cuts off supply of water when the penstock bursts. From the valve house, water is taken to water turbine through a huge steel pipe known as *penstock*. The water turbine converts hydraulic energy into mechanical energy. The turbine drives the alternator which converts mechanical energy into electrical energy.

A surge tank (open from top) is built just before the valve house and protects the penstock from bursting in case the turbine gates suddenly close\* due to electrical load being thrown off. When the

\* The governor opens or closes the turbine gates in accordance with the changes in electrical load. If the electrical load increases, the governor opens the turbine gates to allow more water and *vice-versa*.

gates close, there is a sudden stopping of water at the lower end of the penstock and consequently the penstock can burst like a paper log. The surge tank absorbs this pressure swing by increase in its level of water.

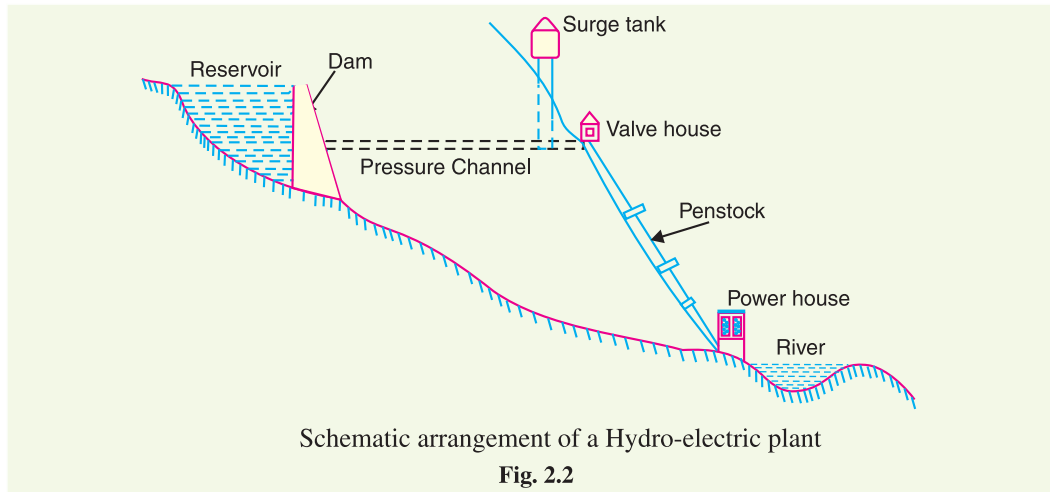

## 2.9 Choice of Site for Hydro-electric Power Stations

The following points should be taken into account while selecting the site for a hydro-electric power station :

- (i) **Availability of water.** Since the primary requirement of a hydro-electric power station is the availability of huge quantity of water, such plants should be built at a place (*e.g.*, river, canal) where adequate water is available at a good head.
- (ii) **Storage of water.** There are wide variations in water supply from a river or canal during the year. This makes it necessary to store water by constructing a dam in order to ensure the generation of power throughout the year. The storage helps in equalising the flow of water so that any excess quantity of water at a certain period of the year can be made available during times of very low flow in the river. This leads to the conclusion that site selected for a hydro-electric plant should provide adequate facilities for erecting a dam and storage of water.
- (iii) **Cost and type of land.** The land for the construction of the plant should be available at a reasonable price. Further, the bearing capacity of the ground should be adequate to withstand the weight of heavy equipment to be installed.
- (iv) **Transportation facilities.** The site selected for a hydro-electric plant should be accessible by rail and road so that necessary equipment and machinery could be easily transported.

It is clear from the above mentioned factors that ideal choice of site for such a plant is near a river in hilly areas where dam can be conveniently built and large reservoirs can be obtained.

## 2.10 Constituents of Hydro-electric Plant

The constituents of a hydro-electric plant are (1) hydraulic structures (2) water turbines and (3) electrical equipment. We shall discuss these items in turn.

**1. Hydraulic structures.** Hydraulic structures in a hydro-electric power station include dam, spillways, headworks, surge tank, penstock and accessory works.

- (i) **Dam.** A dam is a barrier which stores water and creates water head. Dams are built of concrete or stone masonry, earth or rock fill. The type and arrangement depends upon the

topography of the site. A masonry dam may be built in a narrow canyon. An earth dam may be best suited for a wide valley. The type of dam also depends upon the foundation conditions, local materials and transportation available, occurrence of earthquakes and other hazards. At most of sites, more than one type of dam may be suitable and the one which is most economical is chosen.

- (ii) **Spillways.** There are times when the river flow exceeds the storage capacity of the reservoir. Such a situation arises during heavy rainfall in the catchment area. In order to discharge the surplus water from the storage reservoir into the river on the down-stream side of the dam, spillways are used. Spillways are constructed of concrete piers on the top of the dam. Gates are provided between these piers and surplus water is discharged over the crest of the dam by opening these gates.
- (iii) **Headworks.** The headworks consists of the diversion structures at the head of an intake. They generally include booms and racks for diverting floating debris, sluices for by-passing debris and sediments and valves for controlling the flow of water to the turbine. The flow of water into and through headworks should be as smooth as possible to avoid head loss and cavitation. For this purpose, it is necessary to avoid sharp corners and abrupt contractions or enlargements.

- (iv) **Surge tank.** Open conduits leading water to the turbine require no\* protection. However, when closed conduits are used, protection becomes necessary to limit the abnormal pressure in the conduit. For this reason, closed conduits are always provided with a surge tank. A surge tank is a small reservoir or tank (open at the top) in which water level rises or falls to reduce the pressure swings in the conduit.

A surge tank is located near the beginning of the conduit.

When the turbine is running at a steady load, there are no surges in the flow of water through the conduit *i.e.*, the quantity of water flowing in the conduit is just sufficient to meet the turbine requirements. However, when the load on the turbine decreases, the governor closes the gates of turbine, reducing water supply to the turbine. The excess water at the lower end of the conduit rushes back to the surge tank and increases its water level. Thus the conduit is prevented from bursting. On the other hand, when load on the turbine increases, additional water is drawn from the surge tank to meet the increased load requirement. Hence, a surge tank overcomes the abnormal pressure in the conduit when load on the turbine falls and acts as a reservoir during increase of load on the turbine.

- (v) **Penstocks.** Penstocks are open or closed conduits which carry water to the turbines. They are generally made of reinforced concrete or steel. Concrete penstocks are suitable for low

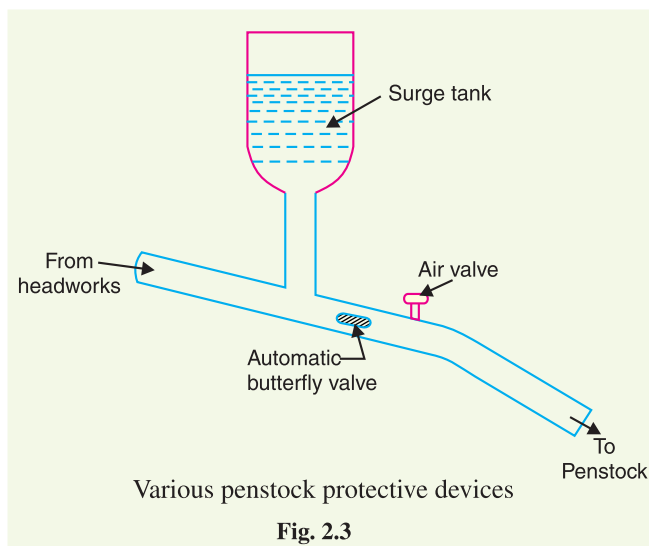

\* Because in case of open conduits, regulating gates control the inflow at the headworks and the spillway discharges the surplus water.

heads ( $< 30$  m) as greater pressure causes rapid deterioration of concrete. The steel penstocks can be designed for any head; the thickness of the penstock increases with the head or working pressure.

Various devices such as automatic butterfly valve, air valve and surge tank (See Fig. 2.3) are provided for the protection of penstocks. Automatic butterfly valve shuts off water flow through the penstock promptly if it ruptures. Air valve maintains the air pressure inside the penstock equal to outside atmospheric pressure. When water runs out of a penstock faster than it enters, a vacuum is created which may cause the penstock to collapse. Under such situations, air valve opens and admits air in the penstock to maintain inside air pressure equal to the outside air pressure.

**2. Water turbines.** Water turbines are used to convert the energy of falling water into mechanical energy. The principal types of water turbines are :

(i) Impulse turbines      (ii) Reaction turbines

(i) **Impulse turbines.** Such turbines are used for high heads. In an impulse turbine, the entire pressure of water is converted into kinetic energy in a nozzle and the velocity of the jet drives the wheel. The example of this type of turbine is the Pelton wheel (See Fig. 2.4). It consists of a wheel fitted with elliptical buckets along its periphery. The force of water jet striking the buckets on the wheel drives the turbine. The quantity of water jet falling on the turbine is controlled by means of a *needle* or *spear* (not shown in the figure) placed in the tip of the nozzle. The movement of the needle is controlled by the governor. If the load on the turbine decreases, the governor pushes the needle into the nozzle, thereby reducing the quantity of water striking the buckets. Reverse action takes place if the load on the turbine increases.

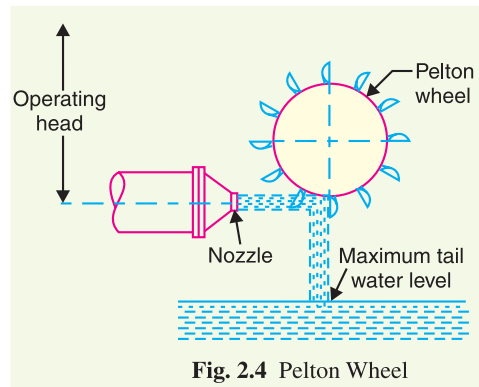

Fig. 2.4 Pelton Wheel

(ii) **Reaction turbines.** Reaction turbines are used for low and medium heads. In a reaction turbine, water enters the runner partly with pressure energy and partly with velocity head. The important types of reaction turbines are :

(a) Francis turbines      (b) Kaplan turbines

A Francis turbine is used for low to medium heads. It consists of an outer ring of stationary guide blades fixed to the turbine casing and an inner ring of rotating blades forming the runner. The guide blades control the flow of water to the turbine. Water flows radially inwards and changes to a downward direction while passing through the runner. As the water passes over the “rotating blades” of the runner, both pressure and velocity of water are reduced. This causes a reaction force which drives the turbine.

A Kaplan turbine is used for low heads and large quantities of water. It is similar to Francis turbine except that the runner of Kaplan turbine receives water axially. Water flows radially inwards



Bhakra Dam



through regulating gates all around the sides, changing direction in the runner to axial flow. This causes a reaction force which drives the turbine.

**3. Electrical equipment.** The electrical equipment of a hydro-electric power station includes alternators, transformers, circuit breakers and other switching and protective devices.

**Example 2.6.** A hydro-electric generating station is supplied from a reservoir of capacity  $5 \times 10^6$  cubic metres at a head of 200 metres. Find the total energy available in kWh if the overall efficiency is 75%.

**Solution.**

Weight of water available is

$$\begin{aligned} W &= \text{Volume of water} \times \text{density} \\ &= (5 \times 10^6) \times (1000) \quad (\because \text{mass of } 1\text{m}^3 \text{ of water is } 1000 \text{ kg}) \\ &= 5 \times 10^9 \text{ kg} = 5 \times 10^9 \times 9.81 \text{ N} \end{aligned}$$

$$\begin{aligned} \text{Electrical energy available} &= W \times H \times \eta_{\text{overall}} = (5 \times 10^9 \times 9.81) \times (200) \times (0.75) \text{ watt sec} \\ &= \frac{(5 \times 10^9 \times 9.81) \times (200) \times (0.75)}{3600 \times 1000} \text{ kWh} = \mathbf{2.044 \times 10^6 \text{ kWh}} \end{aligned}$$

**Example 2.7.** It has been estimated that a minimum run off of approximately  $94 \text{ m}^3/\text{sec}$  will be available at a hydraulic project with a head of 39 m. Determine (i) firm capacity (ii) yearly gross output. Assume the efficiency of the plant to be 80%.

**Solution.**

$$\text{Weight of water available, } W = 94 \times 1000 = 94000 \text{ kg/sec}$$

$$\text{Water head, } H = 39 \text{ m}$$

$$\begin{aligned} \text{Work done/sec} &= W \times H = 94000 \times 9.81 \times 39 \text{ watts} \\ &= 35,963 \times 10^3 \text{ W} = 35,963 \text{ kW} \end{aligned}$$

This is gross plant capacity.

$$\begin{aligned} \text{(i) Firm capacity} &= \text{Plant efficiency} \times \text{Gross plant capacity} \\ &= 0.80 \times 35,963 = \mathbf{28,770 \text{ kW}} \end{aligned}$$

$$\begin{aligned} \text{(ii) Yearly gross output} &= \text{Firm capacity} \times \text{Hours in a year} \\ &= 28,770 \times 8760 = \mathbf{252 \times 10^6 \text{ kWh}} \end{aligned}$$

**Example 2.8.** Water for a hydro-electric station is obtained from a reservoir with a head of 100 metres. Calculate the electrical energy generated per hour per cubic metre of water if the hydraulic efficiency be 0.86 and electrical efficiency 0.92.

**Solution.**

$$\text{Water head, } H = 100 \text{ m ; discharge, } Q = 1 \text{ m}^3/\text{sec ; } \eta_{\text{overall}} = 0.86 \times 0.92 = 0.79$$

$$\text{Wt. of water available/sec, } W = Q \times 1000 \times 9.81 = 9810 \text{ N}$$

$$\begin{aligned} \text{Power produced} &= W \times H \times \eta_{\text{overall}} = 9810 \times 100 \times 0.79 \text{ watts} \\ &= 775 \times 10^3 \text{ watts} = 775 \text{ kW} \end{aligned}$$

$$\therefore \text{Energy generated/hour} = 775 \times 1 = \mathbf{775 \text{ kWh}}$$

**Example 2.9.** Calculate the average power in kW that can be generated in a hydro-electric project from the following data

$$\text{Catchment area} = 5 \times 10^9 \text{ m}^2 ; \text{Mean head, } H = 30 \text{ m}$$

$$\text{Annual rainfall, } F = 1.25 \text{ m ; Yield factor, } K = 80 \%$$

$$\text{Overall efficiency, } \eta_{\text{overall}} = 70 \%$$

If the load factor is 40%, what is the rating of generators installed ?

**Solution.**

Volume of water which can be utilised per annum

$$= \text{Catchment area} \times \text{Annual rainfall} \times \text{*yield factor}$$

$$= (5 \times 10^9) \times (1.25) \times (0.8) = 5 \times 10^9 \text{ m}^3$$

Weight of water available per annum is

$$W = 5 \times 10^9 \times 9.81 \times 1000 = 49.05 \times 10^{12} \text{ N}$$

Electrical energy available per annum

$$= W \times H \times \eta_{\text{overall}} = (49.05 \times 10^{12}) \times (30) \times (0.7) \text{ watt-sec}$$

$$= \frac{(49.05 \times 10^{12}) \times (30) \times (0.7)}{1000 \times 3600} \text{ kWh} = 2.86 \times 10^8 \text{ kWh}$$

$$\therefore \text{Average power} = 2.86 \times 10^8 / 8760 = \mathbf{32648 \text{ kW}}$$

$$\text{Max. demand} = \frac{\text{Average demand}}{\text{Load factor}} = \frac{32648}{0.4} = \mathbf{81620 \text{ kW}}$$

Therefore, the maximum capacity of the generators should be 81620 kW.

**Example 2.10.** A hydro-electric power station has a reservoir of area 2.4 square kilometres and capacity  $5 \times 10^6 \text{ m}^3$ . The effective head of water is 100 metres. The penstock, turbine and generation efficiencies are respectively 95%, 90% and 85%.

- (i) Calculate the total electrical energy that can be generated from the power station.  
 (ii) If a load of 15,000 kW has been supplied for 3 hours, find the fall in reservoir level.

**Solution.**

(i) Wt. of water available,  $W = \text{Volume of reservoir} \times \text{wt. of } 1\text{m}^3 \text{ of water}$

$$= (5 \times 10^6) \times (1000) \text{ kg} = 5 \times 10^9 \times 9.81 \text{ N}$$

Overall efficiency,  $\eta_{\text{overall}} = 0.95 \times 0.9 \times 0.85 = 0.726$

Electrical energy that can be generated

$$= W \times H \times \eta_{\text{overall}} = (5 \times 10^9 \times 9.81) \times (100) \times (0.726) \text{ watt-sec.}$$

$$= \frac{(5 \times 10^9 \times 9.81) \times (100) \times (0.726)}{1000 \times 3600} \text{ kWh} = \mathbf{9,89,175 \text{ kWh}}$$

(ii) Let  $x$  metres be the fall in reservoir level in 3 hours.

$$\text{Average discharge/sec} = \frac{\text{Area of reservoir} \times x}{3 \times 3600} = \frac{2.4 \times 10^6 \times x}{3 \times 3600} = 222.2x \text{ m}^3$$

Wt. of water available/sec,  $W = 222.2x \times 1000 \times 9.81 = 21.8x \times 10^5 \text{ N}$

$$\text{Average power produced} = W \times H \times \eta_{\text{overall}}$$

$$= (21.8x \times 10^5) \times (100) \times (0.726) \text{ watts}$$

$$= 15.84x \times 10^7 \text{ watts} = 15.84x \times 10^4 \text{ kW}$$

But kW produced = 15,000 (given)

$$\therefore 15.84x \times 10^4 = 15,000$$

or  $x = \frac{15,000}{15.84 \times 10^4} = 0.0947 \text{ m} = \mathbf{9.47 \text{ cm}}$

Therefore, the level of reservoir will fall by 9.47 cm.

\* The total rainfall cannot be utilised as a part of it is lost by evaporation or absorption by ground. Yield factor indicates the percentage of rainfall available for utilisation. Thus 80% yield factor means that only 80% of total rainfall can be utilised.

**Alternative method**

$$\text{Level of reservoir} = \frac{\text{Vol. of reservoir}}{\text{Area of reservoir}} = \frac{5 \times 10^6}{2.4 \times 10^6} = 2.083 \text{ m}$$

$$\text{kWh generated in 3 hrs} = 15000 \times 3 = 45,000 \text{ kWh}$$

If kWh generated are 9,89,175 kWh, fall in reservoir level = 2.083 m

If kWh generated are 45,000 kWh, fall in reservoir level

$$= \frac{2.083}{9,89,175} \times 45,000 = 0.0947 \text{ m} = \mathbf{9.47 \text{ cm}}$$

**Example 2.11.** A factory is located near a water fall where the usable head for power generation is 25 m. The factory requires continuous power of 400 kW throughout the year. The river flow in a year is (a) 10 m<sup>3</sup>/sec for 4 months, (b) 6 m<sup>3</sup>/sec for 2 months and (c) 1.5 m<sup>3</sup>/sec for 6 months.

(i) If the site is developed as a run-of-river type of plant, without storage, determine the standby capacity to be provided. Assume that overall efficiency of the plant is 80%.

(ii) If a reservoir is arranged upstream, will any standby unit be necessary? What will be the excess power available?

**Solution.**

**(i) Run of river Plant.** In this type of plant, the whole water of stream is allowed to pass through the turbine for power generation. The plant utilises the water as and when available. Consequently, more power can be generated in a rainy season than in dry season.

<b>(a) When discharge</b>	= 10 m <sup>3</sup> /sec
Wt. of water available/sec, $w$	= $10 \times 1000 \text{ kg} = 10^4 \times 9.81 \text{ N}$
Power developed	= $w \times H \times \eta_{\text{overall}} = (10^4 \times 9.81) \times (25) \times (0.8) \text{ watts}$
	= $1962 \times 10^3 \text{ watts} = 1962 \text{ kW}$
<b>(b) When discharge</b>	= 6 m <sup>3</sup> /sec
Power developed	= $1962 \times 6^*/10 = 1177.2 \text{ kW}$
<b>(c) When discharge</b>	= 1.5 m <sup>3</sup> /sec
Power developed	= $1962 \times 1.5/10 = 294 \text{ kW}$

It is clear that when discharge is 10 m<sup>3</sup>/sec or 6 m<sup>3</sup>/sec, power developed by the plant is more than 400 kW required by the factory. However, when the discharge is 1.5 m<sup>3</sup>/sec, power developed falls short and consequently standby unit is required during this period.

$$\therefore \text{Capacity of standby unit} = 400 - 294 = \mathbf{106 \text{ kW}}$$

**(ii) With reservoir.** When reservoir is arranged upstream, we can store water. This permits regulated supply of water to the turbine so that power output is constant throughout the year.

$$\text{Average discharge} = \frac{(10 \times 4) + (2 \times 6) + (1.5 \times 6)}{12} = 5.08 \text{ m}^3 / \text{sec.}$$

$$\therefore \text{Power developed} = 1962 \times 5.08/10 = 996.7 \text{ kW}$$

Since power developed is more than required by the factory, no standby unit is needed.

$$\therefore \text{Excess power available} = 996.7 - 400 = \mathbf{596.7 \text{ kW}}$$

**Example 2.12.** A run-of-river hydro-electric plant with pondage has the following data :

Installed capacity = 10 MW ; Water head,  $H = 20 \text{ m}$

Overall efficiency,  $\eta_{\text{overall}} = 80\%$  ; Load factor = 40%

\* If discharge is 10 m<sup>3</sup>/sec, power developed = 1962 kW  
 If discharge is 1 m<sup>3</sup>/sec, power developed = 1962/10  
 If discharge is 6 m<sup>3</sup>/sec, power developed = 1962 × 6/10

- (i) Determine the river discharge in  $m^3/sec$  required for the plant.  
 (ii) If on a particular day, the river flow is  $20 m^3/sec$ , what load factor can the plant supply ?

**Solution.**

(i) Consider the duration to be of one week.

$$\begin{aligned} \text{Units generated/week} &= \text{Max. demand} \times \text{L.F.} \times \text{Hours in a week} \\ &= (10 \times 10^3) \times (0.4) \times (24 \times 7) \text{ kWh} \\ &= 67.2 \times 10^4 \text{ kWh} \end{aligned} \quad \dots (i)$$

Let  $Q m^3/sec$  be the river discharge required.

$$\begin{aligned} \text{Wt. of water available/sec, } w &= Q \times 9.81 \times 1000 = 9810 Q \text{ newton} \\ \text{Average power produced} &= w \times H \times \eta_{\text{overall}} = (9810 Q) \times (20) \times (0.8) W \\ &= 156960 Q \text{ watt} = 156.96 Q \text{ kW} \end{aligned}$$

$$\text{Units generated/week} = (156.96 Q) \times 168 \text{ kWh} = 26,369 Q \text{ kWh} \quad \dots (ii)$$

Equating exps. (i) and (ii), we get,

$$26,369 Q = 67.2 \times 10^4$$

$$\therefore Q = \frac{67.2 \times 10^4}{26,369} = 25.48 m^3/sec$$

(ii) If the river discharge on a certain day is  $20 m^3/sec$ , then,

$$\begin{aligned} \text{Power developed} &= 156.96 \times 20 = 3139.2 \text{ kW} \\ \text{Units generated on that day} &= 3139.2 \times 24 = 75,341 \text{ kWh} \\ \text{Load factor} &= \frac{75,341}{10^4 \times 24} \times 100 = 31.4\% \end{aligned}$$

**Example 2.13.** The weekly discharge of a typical hydroelectric plant is as under :

Day	Sun	Mon	Tues	Wed	Thurs	Fri	Sat
Discharge( $m^3/sec$ )	500	520	850	800	875	900	546

The plant has an effective head of 15 m and an overall efficiency of 85%. If the plant operates on 40% load factor, estimate (i) the average daily discharge (ii) pondage required and (iii) installed capacity of proposed plant.

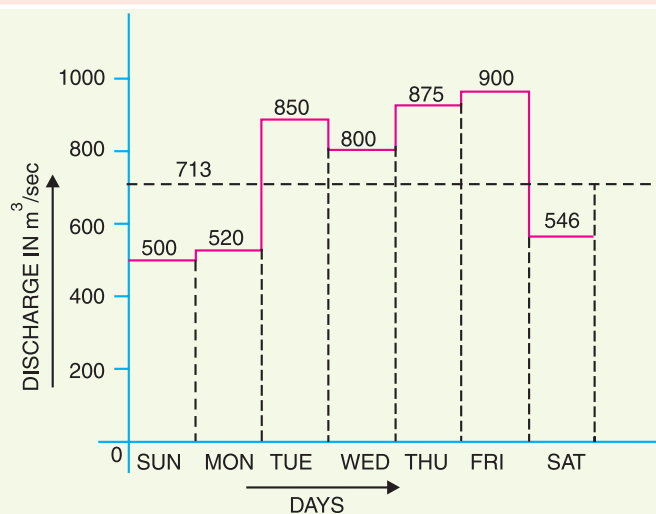

Fig. 2.5

**Solution.**

Fig. 2.5 shows the plot of weekly discharge. In this graph, discharge is taken along Y-axis and days along X-axis.

$$\begin{aligned} \text{(i) Average daily discharge} &= \frac{500 + 520 + 850 + 800 + 875 + 900 + 546}{7} \\ &= \frac{4991}{7} = \mathbf{713 \text{ m}^3/\text{sec}} \end{aligned}$$

**(ii)** It is clear from graph that on three days (*viz.*, Sun, Mon. and Sat.), the discharge is less than the average discharge.

Volume of water actually available on these three days

$$= (500 + 520 + 546) \times 24 \times 3600 \text{ m}^3 = 1566 \times 24 \times 3600 \text{ m}^3$$

Volume of water required on these three days

$$= 3 \times 713 \times 24 \times 3600 \text{ m}^3 = 2139 \times 24 \times 3600 \text{ m}^3$$

Pondage required

$$= (2139 - 1566) \times 24 \times 3600 \text{ m}^3 = \mathbf{495 \times 10^5 \text{ m}^3}$$

**(iii)** Wt. of water available/sec,  $w = 713 \times 1000 \times 9.81 \text{ N}$

$$\begin{aligned} \text{Average power produced} &= w \times H \times \eta_{\text{overall}} = (713 \times 1000 \times 9.81) \times (15) \times (0.85) \text{ watts} \\ &= 89180 \times 10^3 \text{ watts} = 89180 \text{ kW} \end{aligned}$$

Installed capacity of the plant

$$= \frac{\text{Output power}}{\text{Load factor}} = \frac{89180}{0.4} = 223 \times 10^3 \text{ kW} = \mathbf{223 \text{ MW}}$$

**TUTORIAL PROBLEMS**

1. A hydro-electric station has an average available head of 100 metres and reservoir capacity of 50 million cubic metres. Calculate the total energy in kWh that can be generated, assuming hydraulic efficiency of 85% and electrical efficiency of 90%. **[10·423 × 10<sup>6</sup> kWh]**
2. Calculate the continuous power that will be available from hydroelectric plant having an available head of 300 meters, catchment area of 150 sq. km, annual rainfall 1.25 m and yield factor of 50%. Assume penstock, turbine and generator efficiencies to be 96%, 86% and 97% respectively. If the load factor is 40% what should be the rating of the generators installed? **[7065 kW, 17662 kW]**
3. A hydroelectric plant has a reservoir of area 2 sq. kilometres and of capacity 5 million cubic meters. The net head of water at the turbine is 50 m. If the efficiencies of turbine and generator are 85% and 95% respectively, calculate the total energy in kWh that can be generated from this station. If a load of 15000 kW has been supplied for 4 hours, find the fall in reservoir. **[5·5 × 10<sup>5</sup> kWh ; 27·8 cm]**
4. It has been estimated that a minimum run-off of approximately 94 m<sup>3</sup>/sec will be available at a hydraulic project with a head of 39 m. Determine the firm capacity and yearly gross output. **[3600 kW, 315·36 × 10<sup>6</sup> kWh]**

**Hint.** Wt. of water flowing/sec =  $\frac{94 \times (100)^3}{1000} \text{ kg}$

5. A hydroelectric power station is supplied from a reservoir having an area of 50 km<sup>2</sup> and a head of 50 m. If overall efficiency of the plant is 60%, find the rate at which the water level will fall when the station is generating 30,000 kW. **[7·337 mm/hour]**
6. A hydro-electric plant has a catchment area of 120 square km. The available run off is 50% with annual rainfall of 100 cm. A head of 250 m is available on the average. Efficiency of the power plant is 70%. Find (i) average power produced (ii) capacity of the power plant. Assume a load factor of 0.6. **[(i) 3266 kW (ii) 5443 kW]**

## 2.11 Diesel Power Station

A generating station in which diesel engine is used as the prime mover for the generation of electrical energy is known as **diesel power station**.

In a diesel power station, diesel engine is used as the prime mover. The diesel burns inside the engine and the products of this combustion act as the “working fluid” to produce mechanical energy. The diesel engine drives the alternator which converts mechanical energy into electrical energy. As the generation cost is considerable due to high price of diesel, therefore, such power stations are only used to produce small power.

Although steam power stations and hydro-electric plants are invariably used to generate bulk power at cheaper cost, yet diesel power stations are finding favour at places where demand of power is less, sufficient quantity of coal and water is not available and the transportation facilities are inadequate. These plants are also used as standby sets for continuity of supply to important points such as hospitals, radio stations, cinema houses and telephone exchanges.

### Advantages

- (i) The design and layout of the plant are quite simple.
- (ii) It occupies less space as the number and size of the auxiliaries is small.
- (iii) It can be located at any place.
- (iv) It can be started quickly and can pick up load in a short time.
- (v) There are no standby losses.
- (vi) It requires less quantity of water for cooling.
- (vii) The overall cost is much less than that of steam power station of the same capacity.
- (viii) The thermal efficiency of the plant is higher than that of a steam power station.
- (ix) It requires less operating staff.

### Disadvantages

- (i) The plant has high running charges as the fuel (*i.e.*, diesel) used is costly.
- (ii) The plant does not work satisfactorily under overload conditions for a longer period.
- (iii) The plant can only generate small power.
- (iv) The cost of lubrication is generally high.
- (v) The maintenance charges are generally high.

## 2.12 Schematic Arrangement of Diesel Power Station

Fig. 2.6 shows the schematic arrangement of a typical diesel power station. Apart from the diesel-generator set, the plant has the following auxiliaries :

- (i) **Fuel supply system.** It consists of storage tank, strainers, fuel transfer pump and all day fuel tank. The fuel oil is supplied at the plant site by rail or road. This oil is stored in the storage tank. From the storage tank, oil is pumped to smaller all day tank at daily or short intervals. From this tank, fuel oil is passed through strainers to remove suspended impurities. The clean oil is injected into the engine by fuel injection pump.
- (ii) **Air intake system.** This system supplies necessary air to the engine for fuel combustion. It consists of pipes for the supply of fresh air to the engine manifold. Filters are provided to remove dust particles from air which may act as abrasive in the engine cylinder.
- (iii) **Exhaust system.** This system leads the engine exhaust gas outside the building and discharges it into atmosphere. A silencer is usually incorporated in the system to reduce the noise level.



(iv) **Cooling system.** The heat released by the burning of fuel in the engine cylinder is partially converted into work. The remainder part of the heat passes through the cylinder walls, piston, rings etc. and may cause damage to the system. In order to keep the temperature of the engine parts within the safe operating limits, cooling is provided. The cooling system consists of a water source, pump and cooling towers. The pump circulates water through cylinder and head jacket. The water takes away heat from the engine and itself becomes hot. The hot water is cooled by cooling towers and is recirculated for cooling.

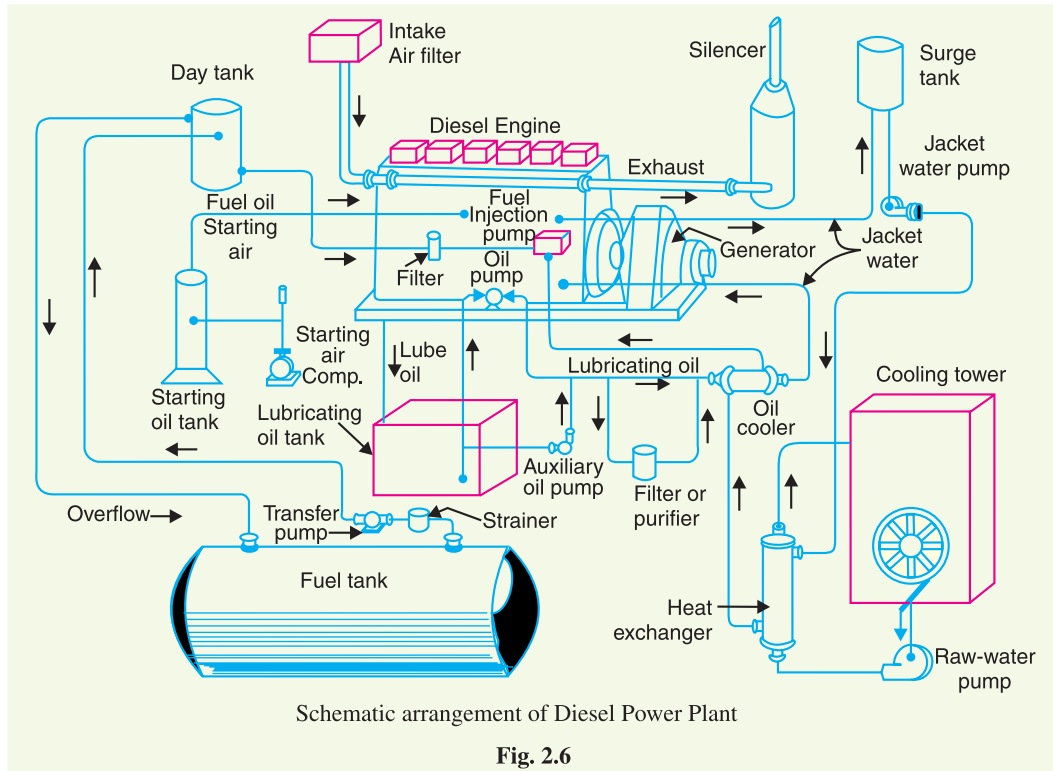

(v) **Lubricating system.** This system minimises the wear of rubbing surfaces of the engine. It comprises of lubricating oil tank, pump, filter and oil cooler. The lubricating oil is drawn from the lubricating oil tank by the pump and is passed through filters to remove impurities. The clean lubricating oil is delivered to the points which require lubrication. The oil coolers incorporated in the system keep the temperature of the oil low.

(vi) **Engine starting system.** This is an arrangement to rotate the engine initially, while starting, until firing starts and the unit runs with its own power. Small sets are started manually by handles but for larger units, compressed air is used for starting. In the latter case, air at high pressure is admitted to a few of the cylinders, making them to act as reciprocating air motors to turn over the engine shaft. The fuel is admitted to the remaining cylinders which makes the engine to start under its own power.

**Example 2.14.** A diesel power station has fuel consumption of 0.28 kg per kWh, the calorific value of fuel being 10,000 kcal/kg. Determine (i) the overall efficiency, and (ii) efficiency of the engine if alternator efficiency is 95%.

**Solution.**

$$\text{Heat produced by 0.28 kg of oil} = 10,000 \times 0.28 = 2800 \text{ kcal}$$

$$\text{Heat equivalent of 1 kWh} = 860 \text{ kcal}$$

$$(i) \quad \text{Overall efficiency} = \frac{\text{Electrical output in heat units}}{\text{Heat of combustion}} = 860/2800 = 0.307 = \mathbf{30.7\%}$$

$$(ii) \quad \text{Engine efficiency} = \frac{\text{Overall efficiency}}{\text{Alternator efficiency}} = \frac{30.7}{0.95} = \mathbf{32.3\%}$$

**Example 2.15.** A diesel power station has the following data :

$$\text{Fuel consumption/day} = 1000 \text{ kg}$$

$$\text{Units generated/day} = 4000 \text{ kWh}$$

$$\text{Calorific value of fuel} = 10,000 \text{ kcal/kg}$$

$$\text{Alternator efficiency} = 96\%$$

$$\text{Engine mech. efficiency} = 95\%$$

Estimate (i) specific fuel consumption, (ii) overall efficiency, and (iii) thermal efficiency of engine.

**Solution.**

$$(i) \quad \text{Specific fuel consumption} = 1000/4000 = \mathbf{0.25 \text{ kg/kWh}}$$

$$(ii) \quad \text{Heat produced by fuel per day}$$

$$= \text{Coal consumption/day} \times \text{calorific value}$$

$$= 1000 \times 10,000 = 10^7 \text{ kcal}$$

$$\text{Electrical output in heat units per day}$$

$$= 4000 \times 860 = 344 \times 10^4 \text{ kcal}$$

$$\text{Overall efficiency} = \frac{344 \times 10^4}{10^7} \times 100 = \mathbf{34.4\%}$$

$$(iii) \quad \text{Engine efficiency, } \eta_{engine} = \frac{\eta_{overall}}{\eta_{alt.}} = \frac{34.4}{0.96} = 35.83\%$$

$$\text{Thermal efficiency, } \eta_{ther} = \frac{\eta_{engine}}{\text{Mech. } \eta \text{ of engine}} = \frac{35.83}{0.95} = \mathbf{37.71\%}$$

**Example 2.16.** A diesel engine power plant has one 700 kW and two 500 kW generating units. The fuel consumption is 0.28 kg per kWh and the calorific value of fuel oil is 10200 kcal/kg. Estimate (i) the fuel oil required for a month of 30 days and (ii) overall efficiency. Plant capacity factor = 40%.

**Solution.**

$$(i) \quad \text{Maximum energy that can be produced in a month}$$

$$= \text{Plant capacity} \times \text{Hours in a month}$$

$$= (700 + 2 \times 500) \times (30 \times 24) = 1700 \times 720 \text{ kWh}$$

$$\text{Plant capacity factor} = \frac{\text{Actual energy produced}}{\text{Max. energy that could have been produced}}$$

$$\text{or} \quad 0.4 = \frac{\text{Actual energy produced}}{1700 \times 720}$$

$$\therefore \text{Actual energy produced in a month}$$

$$= 0.4 \times 1700 \times 720 = 489600 \text{ kWh}$$

$$\text{Fuel oil consumption in a month}$$

$$= 489600 \times 0.28 = \mathbf{137088 \text{ kg}}$$

$$(ii) \quad \text{Output} = 489600 \text{ kWh} = 489600 \times 860 \text{ kcal}$$

$$\text{Input} = 137088 \times 10200 \text{ kcal}$$

$$\therefore \text{Overall efficiency} = \frac{\text{Output}}{\text{Input}} = \frac{489600 \times 860}{137088 \times 10200} = \mathbf{0.3 \text{ or } 30\%}$$

### 2.13 Nuclear Power Station

A generating station in which nuclear energy is converted into electrical energy is known as a **nuclear power station**.

In nuclear power station, heavy elements such as Uranium ( $\text{U}^{235}$ ) or Thorium ( $\text{Th}^{232}$ ) are subjected to nuclear fission\* in a special apparatus known as a **reactor**. The heat energy thus released is utilised in raising steam at high temperature and pressure. The steam runs the steam turbine which converts steam energy into mechanical energy. The turbine drives the alternator which converts mechanical energy into electrical energy.

The most important feature of a nuclear power station is that huge amount of electrical energy can be produced from a relatively small amount of nuclear fuel as compared to other conventional types of power stations. It has been found that complete fission of 1 kg of Uranium ( $\text{U}^{235}$ ) can produce as much energy as can be produced by the burning of 4,500 tons of high grade coal. Although the recovery of principal nuclear fuels (*i.e.*, Uranium and Thorium) is difficult and expensive, yet the total energy content of the estimated world reserves of these fuels are considerably higher than those of conventional fuels, *viz.*, coal, oil and gas. At present, energy crisis is gripping us and, therefore, nuclear energy can be successfully employed for producing low cost electrical energy on a large scale to meet the growing commercial and industrial demands.

#### Advantages

- (i) The amount of fuel required is quite small. Therefore, there is a considerable saving in the cost of fuel transportation.
- (ii) A nuclear power plant requires less space as compared to any other type of the same size.
- (iii) It has low running charges as a small amount of fuel is used for producing bulk electrical energy.
- (iv) This type of plant is very economical for producing bulk electric power.
- (v) It can be located near the load centres because it does not require large quantities of water and need not be near coal mines. Therefore, the cost of primary distribution is reduced.
- (vi) There are large deposits of nuclear fuels available all over the world. Therefore, such plants can ensure continued supply of electrical energy for thousands of years.
- (vii) It ensures reliability of operation.

#### Disadvantages

- (i) The fuel used is expensive and is difficult to recover.
- (ii) The capital cost on a nuclear plant is very high as compared to other types of plants.
- (iii) The erection and commissioning of the plant requires greater technical know-how.
- (iv) The fission by-products are generally radioactive and may cause a dangerous amount of radioactive pollution.

---

\* **Fission.** The breaking up of nuclei of heavy atoms into two nearly equal parts with release of huge amount of energy is known as nuclear fission. The release of huge amount of energy during fission is due to **mass defect** *i.e.* the mass of the final product comes out to be less than the initial product. This mass defect is converted into heat energy according to Einstein's relation,  $E = mc^2$ .

- (v) Maintenance charges are high due to lack of standardisation. Moreover, high salaries of specially trained personnel employed to handle the plant further raise the cost.
- (vi) Nuclear power plants are not well suited for varying loads as the reactor does not respond to the load fluctuations efficiently.
- (vii) The disposal of the by-products, which are radioactive, is a big problem. They have either to be disposed off in a deep trench or in a sea away from sea-shore.

### 2.14 Schematic Arrangement of Nuclear Power Station

The schematic arrangement of a nuclear power station is shown in Fig. 2.7. The whole arrangement can be divided into the following main stages :

- (i) Nuclear reactor
- (ii) Heat exchanger
- (iii) Steam turbine
- (iv) Alternator.

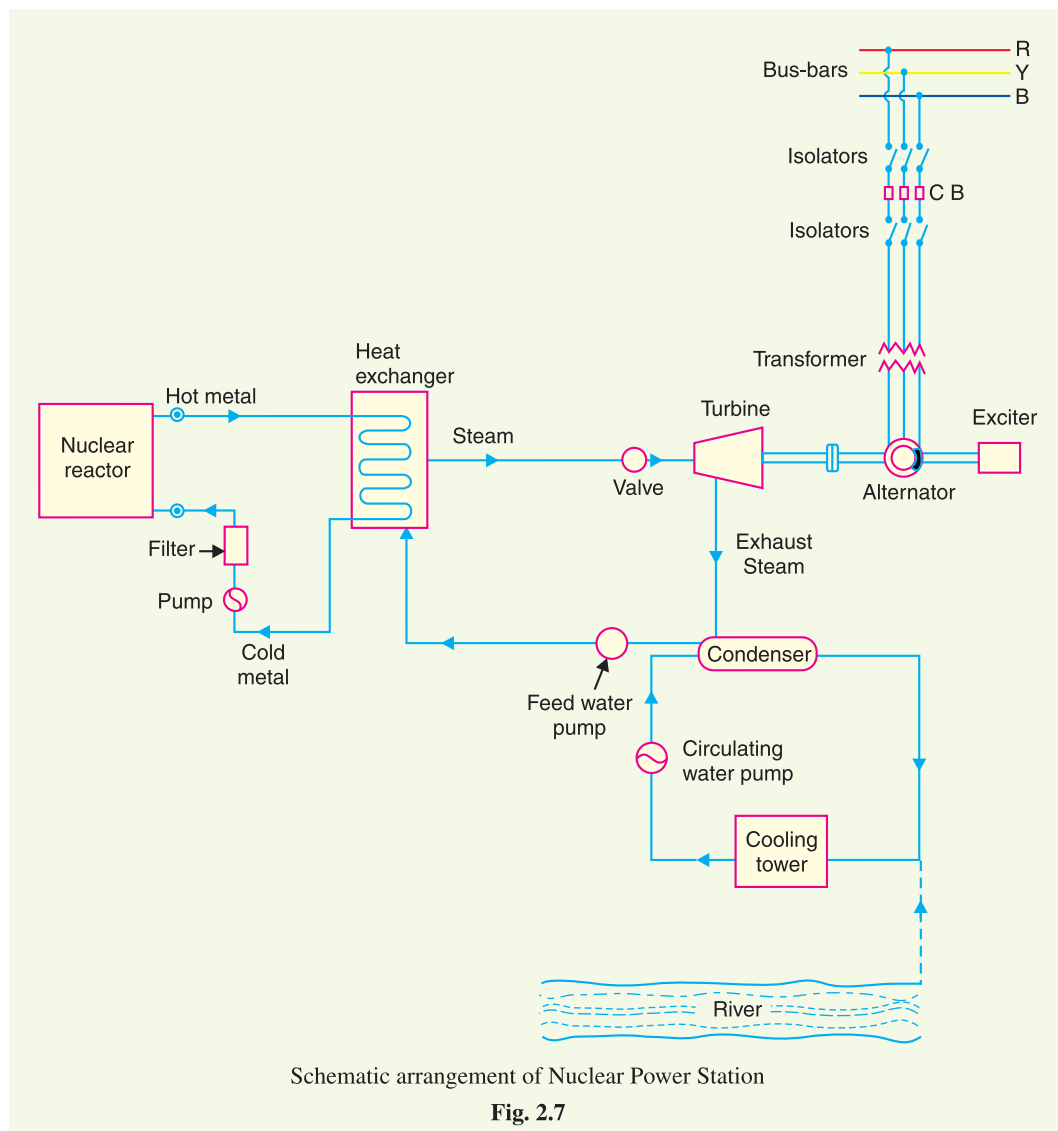

(i) **Nuclear reactor.** It is an apparatus in which nuclear fuel ( $U^{235}$ ) is subjected to nuclear fission. It controls the *chain reaction*\* that starts once the fission is done. If the chain reaction is not controlled, the result will be an explosion due to the fast increase in the energy released.

A nuclear reactor is a cylindrical stout pressure vessel and houses fuel rods of Uranium, moderator and control rods (See Fig. 2.8). The fuel rods constitute the fission material and release huge amount of energy when bombarded with slow moving neutrons. The moderator consists of graphite rods which enclose the fuel rods. The moderator slows down the neutrons before they bombard the fuel rods. The control rods are of cadmium and are inserted into the reactor. Cadmium is strong neutron absorber and thus regulates the supply of neutrons for fission. When the control rods are pushed in deep enough, they absorb most of fission neutrons and hence few are available for chain reaction which, therefore, stops. However, as they are being withdrawn, more and more of these fission neutrons cause fission and hence the *intensity* of chain reaction (or heat produced) is increased. Therefore, by pulling out the control rods, power of the nuclear reactor is increased, whereas by pushing them in, it is reduced. In actual practice, the lowering or raising of control rods is accomplished automatically according to the requirement of load. The heat produced in the reactor is removed by the coolant, generally a sodium metal. The coolant carries the heat to the heat exchanger.

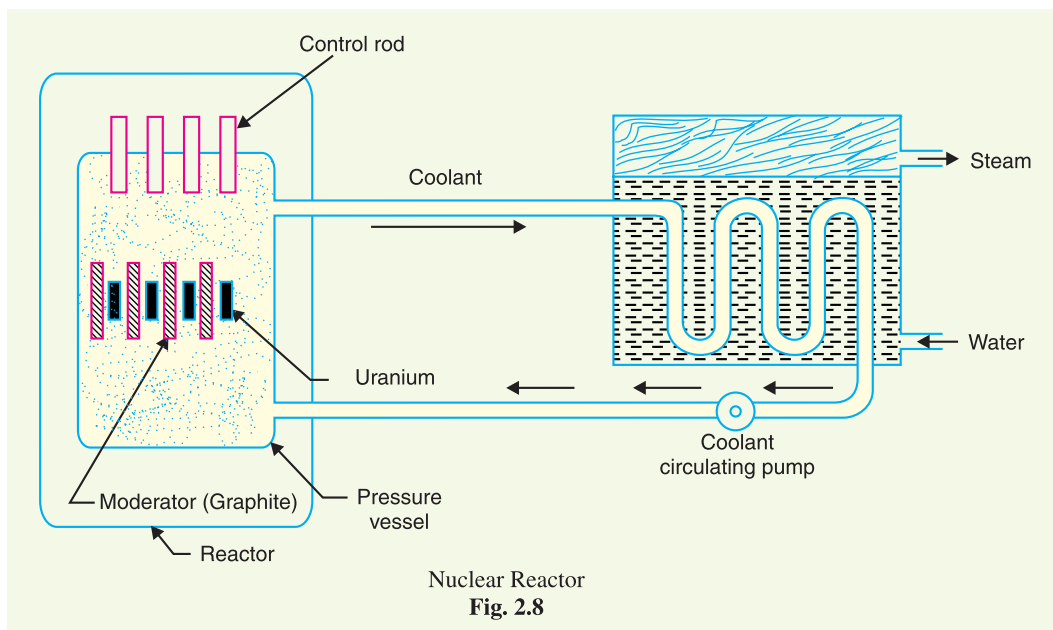

(ii) **Heat exchanger.** The coolant gives up heat to the heat exchanger which is utilised in raising the steam. After giving up heat, the coolant is again fed to the reactor.

\* **Chain reaction.** Nuclear fission is done by bombarding Uranium nuclei with slow moving neutrons. This splits the Uranium nuclei with the release of huge amount of energy and emission of neutrons (called fission neutrons). These fission neutrons cause further fission. If this process continues, then in a very short time huge amount of energy will be released which may cause explosion. This is known as *explosive chain reaction*. But in a reactor, controlled chain reaction is allowed. This is done by systematically removing the fission neutrons from the reactor. The greater the number of fission neutrons removed, the lesser is the intensity (*i.e.*, fission rate) of energy released.

- (iii) **Steam turbine.** The steam produced in the heat exchanger is led to the steam turbine through a valve. After doing a useful work in the turbine, the steam is exhausted to condenser. The condenser condenses the steam which is fed to the heat exchanger through feed water pump.
- (iv) **Alternator.** The steam turbine drives the alternator which converts mechanical energy into electrical energy. The output from the alternator is delivered to the bus-bars through transformer, circuit breakers and isolators.

### 2.15 Selection of Site for Nuclear Power Station

The following points should be kept in view while selecting the site for a nuclear power station :

- (i) **Availability of water.** As sufficient water is required for cooling purposes, therefore, the plant site should be located where ample quantity of water is available, e.g., across a river or by sea-side.
- (ii) **Disposal of waste.** The waste produced by fission in a nuclear power station is generally radioactive which must be disposed off properly to avoid health hazards. The waste should either be buried in a deep trench or disposed off in sea quite away from the sea shore. Therefore, the site selected for such a plant should have adequate arrangement for the disposal of radioactive waste.
- (iii) **Distance from populated areas.** The site selected for a nuclear power station should be quite away from the populated areas as there is a danger of presence of radioactivity in the atmosphere near the plant. However, as a precautionary measure, a *dome* is used in the plant which does not allow the radioactivity to spread by wind or underground waterways.
- (iv) **Transportation facilities.** The site selected for a nuclear power station should have adequate facilities in order to transport the heavy equipment during erection and to facilitate the movement of the workers employed in the plant.

From the above mentioned factors it becomes apparent that ideal choice for a nuclear power station would be near sea or river and away from thickly populated areas.



Nuclear Power Station

**Example 2.17.** An atomic power reactor can deliver 300 MW. If due to fission of each atom of  ${}_{92}\text{U}^{235}$ , the energy released is 200 MeV, calculate the mass of uranium fissioned per hour.



**Solution.**

Energy received from the reactor

$$= 300 \text{ MW} = 3 \times 10^8 \text{ W (or Js}^{-1}\text{)}$$

$$\text{Energy received/hour} = (3 \times 10^8) \times 3600 = 108 \times 10^{10} \text{ J}$$

$$\text{Energy released/fission} = 200 \text{ MeV} = 200 \times 10^6 \times 1.6 \times 10^{-19} \text{ J} = 3.2 \times 10^{-11} \text{ J}$$

Number of atoms fissioned per hour

$$= \frac{108 \times 10^{10}}{3.2 \times 10^{-11}} = 33.75 \times 10^{21}$$

Now 1 gram-atom (*i.e.*, 235g) has  $6.023 \times 10^{23}$  atoms.

$\therefore$  Mass of Uranium fissioned per hour

$$= \frac{235}{6.023 \times 10^{23}} \times 33.75 \times 10^{21} = \mathbf{13.17g}$$

**Example 2.18.** What is the power output of a  ${}_{92}\text{U}^{235}$  reactor if it takes 30 days to use up 2 kg of fuel? Given that energy released per fission is 200 MeV and Avogadro's number =  $6.023 \times 10^{26}$  per kilomole.

**Solution.**

$$\text{Number of atoms in 2 kg fuel} = \frac{2}{235} \times 6.023 \times 10^{26} = 5.12 \times 10^{24}$$

These atoms fission in 30 days. Therefore, the fission rate (*i.e.*, number of fissions per second)

$$= \frac{5.12 \times 10^{24}}{30 \times 24 \times 60 \times 60} = 1.975 \times 10^{18}$$

$$\text{Energy released per fission} = 200 \text{ MeV} = (200 \times 10^6) \times 1.6 \times 10^{-19} = 3.2 \times 10^{-11} \text{ J}$$

$\therefore$  Energy released per second *i.e.*, power output  $P$  is

$$\begin{aligned} P &= (3.2 \times 10^{-11}) \times (1.975 \times 10^{18}) \text{ W} \\ &= 63.2 \times 10^6 \text{ W} = \mathbf{63.2 \text{ MW}} \end{aligned}$$

## 2.16 Gas Turbine Power Plant

A generating station which employs gas turbine as the prime mover for the generation of electrical energy is known as a **gas turbine power plant**

In a gas turbine power plant, air is used as the working fluid. The air is compressed by the compressor and is led to the combustion chamber where heat is added to air, thus raising its temperature. Heat is added to the compressed air either by burning fuel in the chamber or by the use of air heaters. The hot and high pressure air from the combustion chamber is then passed to the gas turbine where it expands and does the mechanical work. The gas turbine drives the alternator which converts mechanical energy into electrical energy.

It may be mentioned here that compressor, gas turbine and the alternator are mounted on the same shaft so that a part of mechanical power of the turbine can be utilised for the operation of the compressor. Gas turbine power plants are being used as standby plants for hydro-electric stations, as a starting plant for driving auxiliaries in power plants etc.

### Advantages

- (i) It is simple in design as compared to steam power station since no boilers and their auxiliaries are required.
- (ii) It is much smaller in size as compared to steam power station of the same capacity. This is expected since gas turbine power plant does not require boiler, feed water arrangement etc.

- (iii) The initial and operating costs are much lower than that of equivalent steam power station.
- (iv) It requires comparatively less water as no condenser is used.
- (v) The maintenance charges are quite small.
- (vi) Gas turbines are much simpler in construction and operation than steam turbines.
- (vii) It can be started quickly from cold conditions.
- (viii) There are no standby losses. However, in a steam power station, these losses occur because boiler is kept in operation even when the steam turbine is supplying no load.

### Disadvantages

- (i) There is a problem for starting the unit. It is because before starting the turbine, the compressor has to be operated for which power is required from some external source. However, once the unit starts, the external power is not needed as the turbine itself supplies the necessary power to the compressor.
- (ii) Since a greater part of power developed by the turbine is used in driving the compressor, the net output is low.
- (iii) The overall efficiency of such plants is low (about 20%) because the exhaust gases from the turbine contain sufficient heat.
- (iv) The temperature of combustion chamber is quite high (3000°F) so that its life is comparatively reduced.

### 2.17 Schematic Arrangement of Gas Turbine Power Plant

The schematic arrangement of a gas turbine power plant is shown in Fig. 2.9. The main components of the plant are :

- |                          |                     |
|--------------------------|---------------------|
| (i) Compressor           | (ii) Regenerator    |
| (iii) Combustion chamber | (iv) Gas turbine    |
| (v) Alternator           | (vi) Starting motor |

- (i) **Compressor.** The compressor used in the plant is generally of rotatory type. The air at atmospheric pressure is drawn by the compressor *via* the filter which removes the dust from air. The rotatory blades of the compressor push the air between stationary blades to raise its pressure. Thus air at high pressure is available at the output of the compressor.
- (ii) **Regenerator.** A regenerator is a device which recovers heat from the exhaust gases of the turbine. The exhaust is passed through the regenerator before wasting to atmosphere. A regenerator consists of a nest of tubes contained in a shell. The compressed air from the compressor passes through the tubes on its way to the combustion chamber. In this way, compressed air is heated by the hot exhaust gases.
- (iii) **Combustion chamber.** The air at high pressure from the compressor is led to the combustion chamber *via* the regenerator. In the combustion chamber, heat\* is added to the air by burning oil. The oil is injected through the burner into the chamber at high pressure to ensure atomisation of oil and its thorough mixing with air. The result is that the chamber attains a very high temperature (about 3000°F). The combustion gases are suitably cooled to 1300°F to 1500°F and then delivered to the gas turbine.
- (iv) **Gas turbine.** The products of combustion consisting of a mixture of gases at high temperature and pressure are passed to the gas turbine. These gases in passing over the turbine blades expand and thus do the mechanical work. The temperature of the exhaust gases from the turbine is about 900°F.

\* Only hot pressurised air makes it possible to convert heat into mechanical work. Heating air at atmospheric pressure generally does not make it permissible to convert heat into mechanical work.

### 2.18 Comparison of the Various Power Plants

The comparison of steam power plant, hydro-electric plant, diesel power plant and nuclear power plant is given below in the tabular form :

S.No.	Item	Steam Power Station	Hydro-electric Power Plant	Diesel Power Plant	Nuclear power Plant
1.	<i>Site</i>	Such plants are located at a place where ample supply of water and coal is available, transportation facilities are adequate	Such plants are located where large reservoirs can be obtained by constructing a dam e.g. in hilly areas.	Such plants can be located at any place because they require less space and small quantity of water.	These plants are located away from thickly populated areas to avoid radioactive pollution.
2.	<i>Initial cost</i>	Initial cost is lower than those of hydroelectric and nuclear power plants.	Initial cost is very high because of dam construction and excavation work.	Initial cost is less as compared to other plants.	Initial cost is highest because of huge investment on building a nuclear reactor.
3.	<i>Running cost</i>	Higher than hydroelectric and nuclear plant because of the requirement of huge amount of coal.	Practically nil because no fuel is required.	Highest among all plants because of high price of diesel.	Except the hydroelectric plant, it has the minimum running cost because small amount of fuel can produce relatively large amount of power.
4.	<i>Limit of source of power</i>	Coal is the source of power which has limited reserves all over the world.	Water is the source of power which is not dependable because of wide variations in the rainfall every year.	Diesel is the source of power which is not available in huge quantities due to limited reserves.	The source of power is the nuclear fuel which is available in sufficient quantity. It is because small amount of fuel can produce huge power.
5.	<i>Cost of fuel transportation</i>	Maximum because huge amount of coal is transported to the plant site.	Practically nil.	Higher than hydro and nuclear power plants	Minimum because small quantity of fuel is required.
6.	<i>Cleanliness and simplicity</i>	Least clean as atmosphere is polluted due to smoke.	Most simple and clean.	More clean than steam power and nuclear power plants.	Less cleaner than hydro-electric and diesel power plants.

S.No.	Item	Steam Power Station	Hydro-electric Power Plant	Diesel Power Plant	Nuclear power Plant
7.	<i>Overall efficiency</i>	Least efficient. Overall efficiency is about 25%.	Most efficient. Overall efficiency is about 85%.	More efficient than steam power station. Efficiency is about 35%.	More efficient than steam power station.
8.	<i>Starting</i>	Requires a lot of time for starting.	Can be started instantly.	Can be started quickly.	Can be started easily.
9.	<i>Space required</i>	These plants need sufficient space because of boilers and other auxiliaries.	Require very large area because of the reservoir.	Require less space.	These require minimum space as compared to any other plant of equivalent capacity.
10.	<i>Maintenance cost</i>	Quite high as skilled operating staff is required.	Quite low.	Less	Very high as highly trained personnel are required to handle the plant.
11.	<i>Transmission and distribution cost</i>	Quite low as these are generally located near the load centres.	Quite high as these are located quite away from the load centres.	Least as they are generally located at the centre of gravity of the load.	Quite low as these are located near load centres.
12.	<i>Standby losses</i>	Maximum as the boiler remains in operation even when the turbine is not working.	No standby losses.	Less standby losses.	Less.

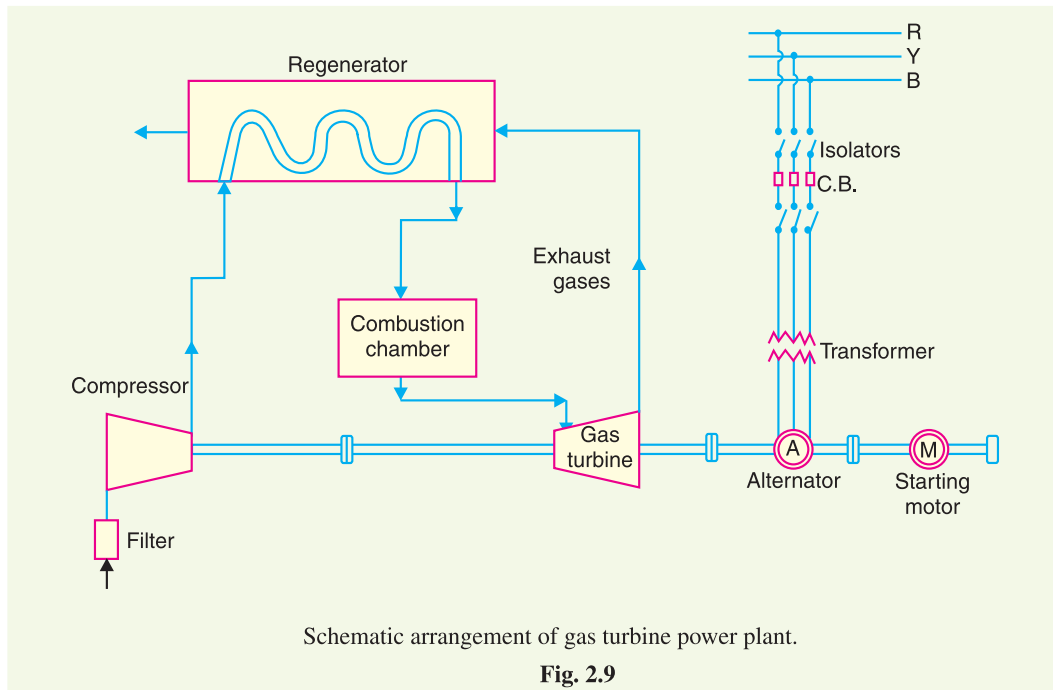

- (v) **Alternator.** The gas turbine is coupled to the alternator. The alternator converts mechanical energy of the turbine into electrical energy. The output from the alternator is given to the bus-bars through transformer, circuit breakers and isolators.
- (vi) **Starting motor.** Before starting the turbine, compressor has to be started. For this purpose, an electric motor is mounted on the same shaft as that of the turbine. The motor is energised by the batteries. Once the unit starts, a part of mechanical power of the turbine drives the compressor and there is no need of motor now.

### SELF-TEST

1. **Fill in the blanks by inserting appropriate words/figures :**
  - (i) The major heat loss in a steam power station occurs in .....
  - (ii) The thermal efficiency of a steam power station is about .....
  - (iii) Cooling towers are used where .....
  - (iv) The running cost of medium power stations is about ..... paise per unit.
  - (v) In a hydro-electric plant, spillways are used .....
  - (vi) The running cost of a hydro-electric plant is about ..... paise per unit.
  - (vii) For high head hydro-electric plants, the turbine used is .....
  - (viii) Francis and Kaplan turbines are used for ..... heads.
  - (ix) Surge tank is provided for the protection of .....
  - (x) Of all the plants, minimum quantity of fuel is required in ..... plant.
2. **Pick up the correct words from the brackets and fill in the blanks :**
  - (i) The cost of fuel transportation is minimum in ..... plant.  
(steam power, hydro-electric, nuclear power)
  - (ii) The cheapest plant in operation and maintenance is ..... plant.  
(diesel power, hydro-electric, steam power)
  - (iii) Economisers are used to heat .....

- (iv) The running cost of a nuclear power plant is about ..... paise per unit. (20, 48, 64)  
 (v) Diesel power plants are used as ..... plants. (base load, standby)  
 (vi) India's first nuclear power plant was built at ..... (Tarapur, Rana Partap Sagar, Kalpakkam)  
 (vii) The most simple and clean plant is ..... plant (steam power, hydro-electric, nuclear power)  
 (viii) The first nuclear power plant in the world was commissioned in ..... (U.S.A., U.S.S.R., England)  
 (ix) Gas turbine power plant is ..... efficient than steam power plant, (more, less)  
 (x) Draft tube is used in ..... turbines. (impulse, reaction)

### ANSWERS TO SELF-TEST

- (i) Condenser, about 53% (ii) 28% (iii) water is not available in sufficient quantity (iv) 15 (v) to discharge surplus water on the downstream side of dam (vi) 5 (vii) pelton wheel (viii) medium and low (ix) penstock (x) nuclear power.
- (i) Hydro-electric (ii) hydro-electric (iii) feed water (iv) 20 (v) standby (vi) Tarapur (vii) hydro-electric (viii) U.S.S.R. in 1954 (ix) more (x) reaction.

### CHAPTER REVIEW TOPICS

- What is a power generating station ?
- What is a steam power station ? Discuss its advantages and disadvantages.
- Draw the schematic diagram of a modern steam power station and explain its operation.
- Explain the important components of a steam power station.
- What factors are taken into account while selecting the site for a steam power station ?
- Discuss the merits and demerits of a hydro-electric plant.
- Draw a neat schematic diagram of a hydro-electric plant and explain the functions of various components.
- Explain the essential factors which influence the choice of site for a hydro-electric plant.
- Explain the functions of the following :  
 (i) dam (ii) spillways (iii) surge tank (iv) headworks (v) draft tube.
- Draw the flow diagram of a diesel power station and discuss its operation.
- Discuss the advantages and disadvantages of a diesel power station.
- Draw the schematic diagram of a nuclear power station and discuss its operation.
- Explain with a neat sketch the various parts of a nuclear reactor.
- Discuss the factors for the choice of site for a nuclear power plant.
- Explain the working of a gas turbine power plant with a schematic diagram.
- Give the comparison of steam power plant, hydro-electric power plant, diesel power plant and nuclear power plant on the basis of operating cost, initial cost, efficiency, maintenance cost and availability of source of power.

### DISCUSSION QUESTIONS

- Why is the overall efficiency of a steam power station very low ?
- Why is a condenser used in a steam power station ?
- Why hydro-electric stations have high transmission and distribution costs ?
- Why are nuclear power stations becoming very popular ?
- Why hot gas at high pressure and not hot gas at atmospheric pressure is used in gas turbine power plants?
- How do the various devices protect the penstock ?
- Why cannot diesel power stations be employed to generate bulk power ?
- Why is regenerator used in gas turbine power plant ?