

CHAPTER

8



Mechanical Design of Overhead Lines

- 8.1 Main Components of Overhead Lines
- 8.2 Conductor Materials
- 8.3 Line Supports
- 8.4 Insulators
- 8.5 Types of Insulators
- 8.6 Potential Distribution over Suspension Insulator String
- 8.7 String Efficiency
- 8.8 Methods of Improving String Efficiency
- 8.9 Important Points
- 8.10 Corona
- 8.11 Factors Affecting Corona
- 8.12 Important Terms
- 8.13 Advantages and Disadvantages of Corona
- 8.14 Methods of Reducing Corona Effect
- 8.15 Sag in Overhead Lines
- 8.16 Calculation of Sag
- 8.17 Some Mechanical Principles

Introduction

Electric power can be transmitted or distributed either by means of underground cables or by overhead lines. The underground* cables are rarely used for power transmission due to two main reasons. Firstly, power is generally transmitted over long distances to load centres. Obviously, the installation costs for underground transmission will be very heavy. Secondly, electric power has to be transmitted at high voltages for economic reasons. It is very difficult to provide proper insulation† to the cables to withstand such higher pressures. Therefore, as a rule, power transmission over long distances is carried out by using overhead lines. With the growth in power demand and consequent rise in voltage levels, power transmission by overhead lines has assumed considerable importance.

* The underground system is much more expensive than overhead system. Therefore, it has limited use for distribution in congested areas where safety and good appearances are the main considerations.

† In overhead lines, bare conductors are used and air acts as the insulation. The necessary insulation between the conductors can be provided by adjusting the spacing between them.

An overhead line is subjected to uncertain weather conditions and other external interferences. This calls for the use of proper mechanical factors of safety in order to ensure the continuity of operation in the line. In general, the strength of the line should be such so as to provide against the worst *probable* weather conditions. In this chapter, we shall focus our attention on the various aspects of mechanical design of overhead lines.

8.1 Main Components of Overhead Lines

An overhead line may be used to transmit or distribute electric power. The successful operation of an overhead line depends to a great extent upon the mechanical design of the line. While constructing an overhead line, it should be ensured that mechanical strength of the line is such so as to provide against the most *probable* weather conditions. In general, the main components of an overhead line are:

- (i) **Conductors** which carry electric power from the sending end station to the receiving end station.
- (ii) **Supports** which may be poles or towers and keep the conductors at a suitable level above the ground.
- (iii) **Insulators** which are attached to supports and insulate the conductors from the ground.
- (iv) **Cross arms** which provide support to the insulators.
- (v) **Miscellaneous items** such as phase plates, danger plates, lightning arrestors, anti-climbing wires etc.

The continuity of operation in the overhead line depends upon the judicious choice of above components. Therefore, it is profitable to have detailed discussion on them.

8.2 Conductor Materials

The conductor is one of the important items as most of the capital outlay is invested for it. Therefore, proper choice of material and size of the conductor is of considerable importance. The conductor material used for transmission and distribution of electric power should have the following properties :

- (i) high electrical conductivity.
- (ii) high tensile strength in order to withstand mechanical stresses.
- (iii) low cost so that it can be used for long distances.
- (iv) low specific gravity so that weight per unit volume is small.

All above requirements are not found in a single material. Therefore, while selecting a conductor material for a particular case, a compromise is made between the cost and the required electrical and mechanical properties.

Commonly used conductor materials. The most commonly used conductor materials for overhead lines are *copper, aluminium, steel-cored aluminium, galvanised steel* and *cadmium copper*. The choice of a particular material will depend upon the cost, the required electrical and mechanical properties and the local conditions.

All conductors used for overhead lines are preferably stranded* in order to increase the flexibility. In stranded conductors, there is generally one central wire and round this, successive layers of wires containing 6, 12, 18, 24 wires. Thus, if there are n layers, the total number of individual wires is $3n(n + 1) + 1$. In the manufacture of stranded conductors, the consecutive layers of wires are twisted or spiralled in opposite directions so that layers are bound together.

1. Copper. Copper is an ideal material for overhead lines owing to its high electrical conductivity and greater tensile strength. It is always used in the hard drawn form as stranded conductor.

* Solid wires are only used when area of X-section is small. If solid wires are used for larger X-section and longer spans, continuous vibrations and swinging would produce mechanical fatigue and they would fracture at the points of support.

Although hard drawing decreases the electrical conductivity slightly yet it increases the tensile strength considerably.

Copper has high current density *i.e.*, the current carrying capacity of copper per unit of X-sectional area is quite large. This leads to two advantages. Firstly, smaller X-sectional area of conductor is required and secondly, the area offered by the conductor to wind loads is reduced. Moreover, this metal is quite homogeneous, durable and has high scrap value.

There is hardly any doubt that copper is an ideal material for transmission and distribution of electric power. However, due to its higher cost and non-availability, it is rarely used for these purposes. Now-a-days the trend is to use aluminium in place of copper.

2. Aluminium. Aluminium is cheap and light as compared to copper but it has much smaller conductivity and tensile strength. The relative comparison of the two materials is briefed below :

- (i) The conductivity of aluminium is 60% that of copper. The smaller conductivity of aluminium means that for any particular transmission efficiency, the X-sectional area of conductor must be larger in aluminium than in copper. For the same resistance, the diameter of aluminium conductor is about 1.26 times the diameter of copper conductor.

The increased X-section of aluminium exposes a greater surface to wind pressure and, therefore, supporting towers must be designed for greater transverse strength. This often requires the use of higher towers with consequence of greater sag.

- (ii) The specific gravity of aluminium (2.71 gm/cc) is lower than that of copper (8.9 gm/cc). Therefore, an aluminium conductor has almost one-half the weight of equivalent copper conductor. For this reason, the supporting structures for aluminium need not be made so strong as that of copper conductor.
- (iii) Aluminium conductor being light, is liable to greater swings and hence larger cross-arms are required.
- (iv) Due to lower tensile strength and higher co-efficient of linear expansion of aluminium, the sag is greater in aluminium conductors.

Considering the combined properties of cost, conductivity, tensile strength, weight etc., aluminium has an edge over copper. Therefore, it is being widely used as a conductor material. It is particularly profitable to use aluminium for heavy-current transmission where the conductor size is large and its cost forms a major proportion of the total cost of complete installation.

3. Steel cored aluminium. Due to low tensile strength, aluminium conductors produce greater sag. This prohibits their use for larger spans and makes them unsuitable for long distance transmission. In order to increase the tensile strength, the aluminium conductor is reinforced with a core of galvanised steel wires. The *composite conductor thus obtained is known as *steel cored aluminium* and is abbreviated as A.C.S.R. (aluminium conductor steel reinforced).

Steel-cored aluminium conductor consists of central core of †galvanised steel wires surrounded by a number of aluminium strands. Usually, diameter of both steel and aluminium wires is the same. The X-section of the two metals are generally in the ratio of 1 : 6 but can be modified to 1 : 4 in order to get more tensile strength for the conductor. Fig. 8.1 shows steel cored aluminium conductor having one steel wire surrounded by six wires of aluminium. The result of this composite conductor is that steel core takes greater percentage of

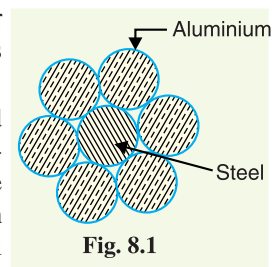

* The reader may think that reinforcement with steel increases the weight but actually the weight of composite conductor is 25% less as compared with equivalent copper conductor.

† The galvanised steel is used in order to prevent rusting and electrolytic corrosion.

mechanical strength while aluminium strands carry the bulk of current. The steel cored aluminium conductors have the following advantages :

- (i) The reinforcement with steel increases the tensile strength but at the same time keeps the composite conductor light. Therefore, steel cored aluminium conductors will produce smaller sag and hence longer spans can be used.
- (ii) Due to smaller sag with steel cored aluminium conductors, towers of smaller heights can be used.

4. Galvanised steel. Steel has very high tensile strength. Therefore, galvanised steel conductors can be used for extremely long spans or for short line sections exposed to abnormally high stresses due to climatic conditions. They have been found very suitable in rural areas where cheapness is the main consideration. Due to poor conductivity and high resistance of steel, such conductors are not suitable for transmitting large power over a long distance. However, they can be used to advantage for transmitting a small power over a small distance where the size of the copper conductor desirable from economic considerations would be too small and thus unsuitable for use because of poor mechanical strength.

5. Cadmium copper. The conductor material now being employed in certain cases is copper alloyed with cadmium. An addition of 1% or 2% cadmium to copper increases the tensile strength by about 50% and the conductivity is only reduced by 15% below that of pure copper. Therefore, cadmium copper conductor can be useful for exceptionally long spans. However, due to high cost of cadmium, such conductors will be economical only for lines of small X-section *i.e.*, where the cost of conductor material is comparatively small compared with the cost of supports.

8.3 Line Supports

The supporting structures for overhead line conductors are various types of poles and towers called *line supports*. In general, the line supports should have the following properties :

- (i) High mechanical strength to withstand the weight of conductors and wind loads etc.
- (ii) Light in weight without the loss of mechanical strength.
- (iii) Cheap in cost and economical to maintain.
- (iv) Longer life.
- (v) Easy accessibility of conductors for maintenance.

The line supports used for transmission and distribution of electric power are of various types including *wooden poles, steel poles, R.C.C. poles* and *lattice steel towers*. The choice of supporting structure for a particular case depends upon the line span, X-sectional area, line voltage, cost and local conditions.

1. Wooden poles. These are made of seasoned wood (sal or chir) and are suitable for lines of moderate X-sectional area and of relatively shorter spans, say upto 50 metres. Such supports are cheap, easily available, provide insulating properties and, therefore, are widely used for distribution purposes in rural areas as an economical proposition. The wooden poles generally tend to rot below the ground level, causing foundation failure. In order to prevent this, the portion of the pole below the ground level is impregnated with preservative compounds like *creosote oil*. Double pole structures of the 'A' or 'H' type are often used (See Fig. 8.2) to obtain a higher transverse strength than could be economically provided by means of single poles.

The main objections to wooden supports are : (i) tendency to rot below the ground level (ii) comparatively smaller life (20-25 years) (iii) cannot be used for voltages higher than 20 kV (iv) less mechanical strength and (v) require periodical inspection.

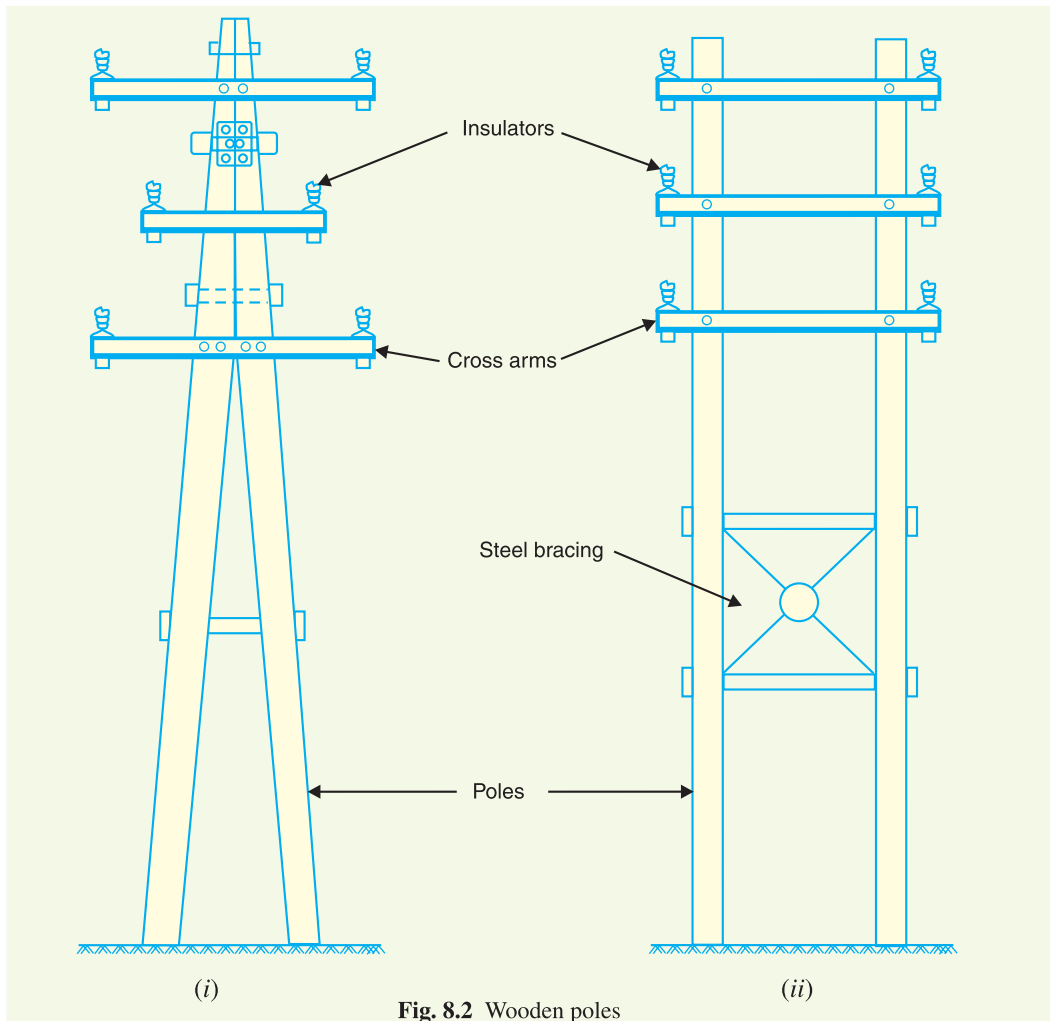

Fig. 8.2 Wooden poles

2. Steel poles. The steel poles are often used as a substitute for wooden poles. They possess greater mechanical strength, longer life and permit longer spans to be used. Such poles are generally used for distribution purposes in the cities. This type of supports need to be galvanised or painted in order to prolong its life. The steel poles are of three types *viz.*, (i) rail poles (ii) tubular poles and (iii) rolled steel joints.

3. RCC poles. The reinforced concrete poles have become very popular as line supports in recent years. They have greater mechanical strength, longer life and permit longer spans than steel poles. Moreover, they give good outlook, require little maintenance and have good insulating properties. Fig. 8.3 shows R.C.C. poles for single and double circuit. The holes in the poles facilitate the climbing of poles and at the same time reduce the weight of line supports.

The main difficulty with the use of these poles is the high cost of transport owing to their heavy weight. Therefore, such poles are often manufactured at the site in order to avoid heavy cost of transportation.

4. Steel towers. In practice, wooden, steel and reinforced concrete poles are used for distribution purposes at low voltages, say upto 11 kV. However, for long distance transmission at higher voltage, steel towers are invariably employed. Steel towers have greater mechanical strength, longer

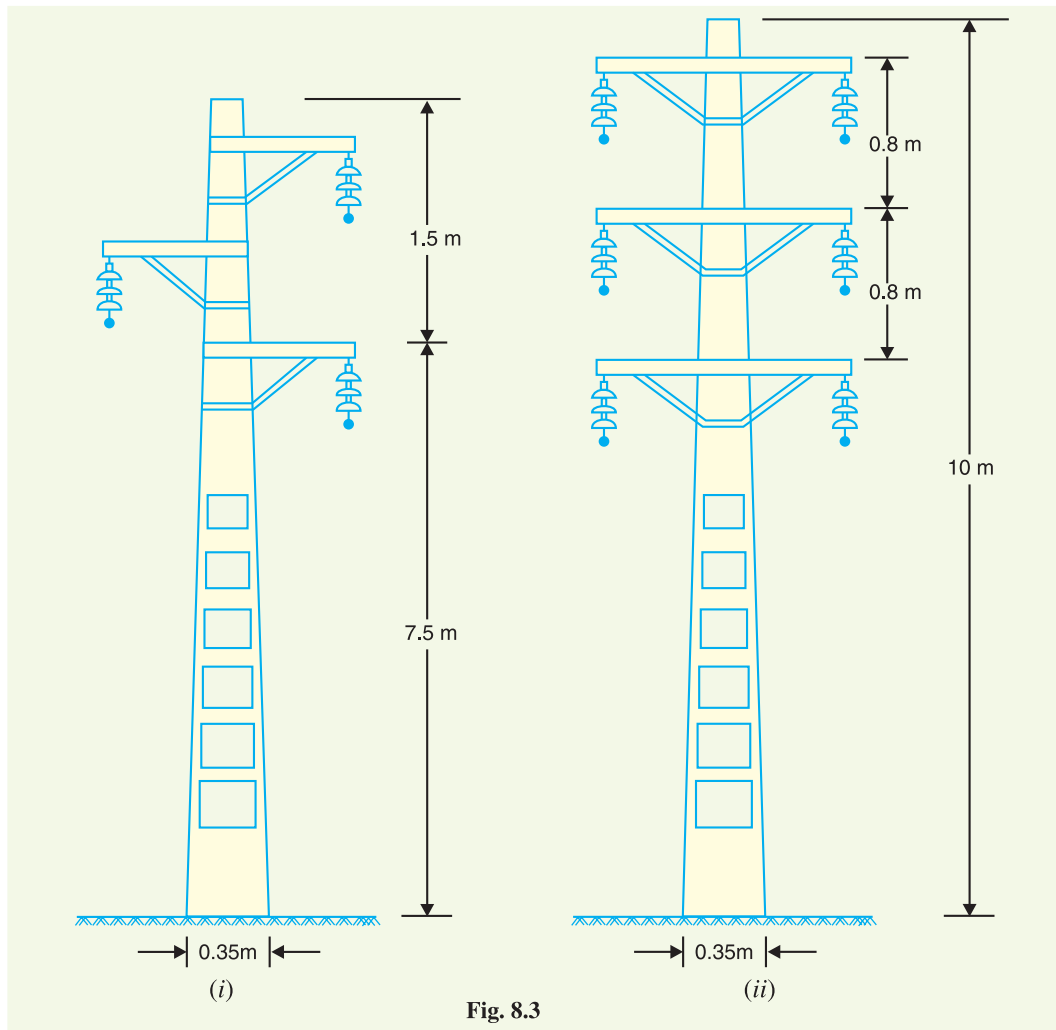

Fig. 8.3

life, can withstand most severe climatic conditions and permit the use of longer spans. The risk of interrupted service due to broken or punctured insulation is considerably reduced owing to longer spans. Tower footings are usually grounded by driving rods into the earth. This minimises the lightning troubles as each tower acts as a lightning conductor.

Fig. 8.4 (i) shows a single circuit tower. However, at a moderate additional cost, double circuit tower can be provided as shown in Fig. 8.4 (ii). The double circuit has the advantage that it ensures continuity of supply. In case there is breakdown of one circuit, the continuity of supply can be maintained by the other circuit.

8.4 Insulators

The overhead line conductors should be supported on the poles or towers in such a way that currents from conductors do not flow to earth through supports *i.e.*, line conductors must be properly insulated from supports. This is achieved by securing line conductors to supports with the help of *insulators*. The insulators provide necessary insulation between line conductors and supports and thus prevent any leakage current from conductors to earth. In general, the insulators should have the following desirable properties :

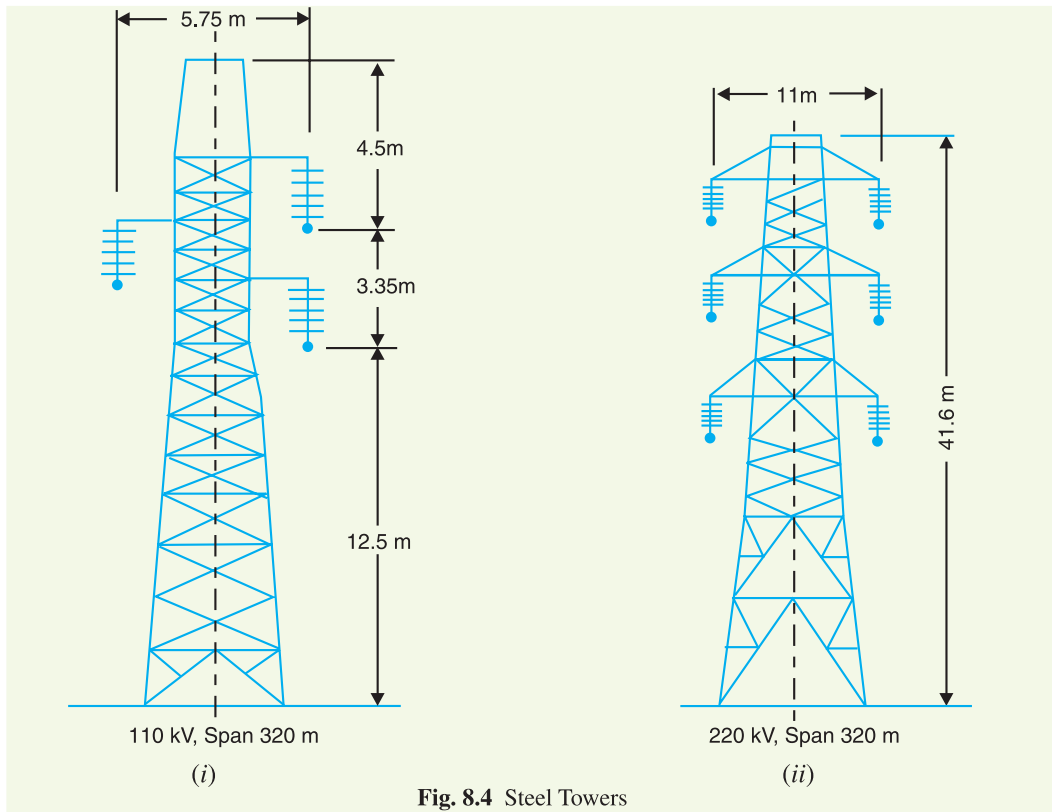

- (i) High mechanical strength in order to withstand conductor load, wind load etc.
- (ii) High electrical resistance of insulator material in order to avoid leakage currents to earth.
- (iii) High relative permittivity of insulator material in order that dielectric strength is high.
- (iv) The insulator material should be non-porous, free from impurities and cracks otherwise the permittivity will be lowered.
- (v) High ratio of puncture strength to flashover.

The most commonly used material for insulators of overhead line is *porcelain* but glass, steatite and special composition materials are also used to a limited extent. Porcelain is produced by firing at a high temperature a mixture of kaolin, feldspar and quartz. It is stronger mechanically than glass, gives less trouble from leakage and is less effected by changes of temperature.

8.5 Types of Insulators

The successful operation of an overhead line depends to a considerable extent upon the proper selection of insulators. There are several types of insulators but the most commonly used are pin type, suspension type, strain insulator and shackle insulator.

1. Pin type insulators. The part section of a pin type insulator is shown in Fig. 8.5 (i). As the name suggests, the pin type insulator is secured to the cross-arm on the

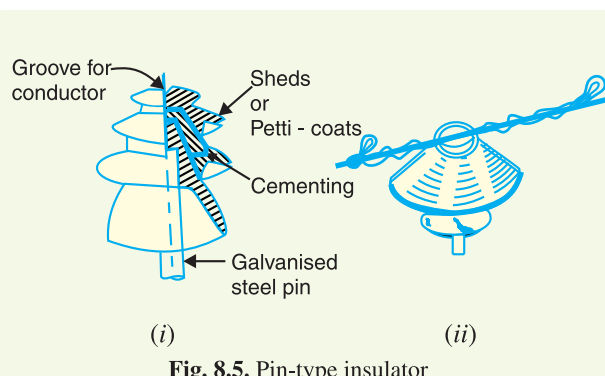

pole. There is a groove on the upper end of the insulator for housing the conductor. The conductor passes through this groove and is bound by the annealed wire of the same material as the conductor [See Fig. 8.5 (ii)].

Pin type insulators are used for transmission and distribution of electric power at voltages upto 33 kV. Beyond operating voltage of 33 kV, the pin type insulators become too bulky and hence uneconomical.

Causes of insulator failure. Insulators are required to withstand both mechanical and electrical stresses. The latter type is primarily due to line voltage and may cause the breakdown of the insulator. The electrical breakdown of the insulator can occur either by *flash-over* or *puncture*. In flash-over, an arc occurs between the line conductor and insulator pin (i.e., earth) and the discharge jumps across the *air gaps, following shortest distance. Fig. 8.6 shows the arcing distance (i.e. $a + b + c$) for the insulator. In case of flash-over, the insulator will continue to act in its proper capacity unless extreme heat produced by the arc destroys the insulator.

In case of puncture, the discharge occurs from conductor to pin through the body of the insulator. When such breakdown is involved, the insulator is permanently destroyed due to excessive heat. In practice, sufficient thickness of porcelain is provided in the insulator to avoid puncture by the line voltage. The ratio of puncture strength to flash-over voltage is known as safety factor i.e.,

$$\text{Safety factor of insulator} = \frac{\text{Puncture strength}}{\text{Flash - over voltage}}$$

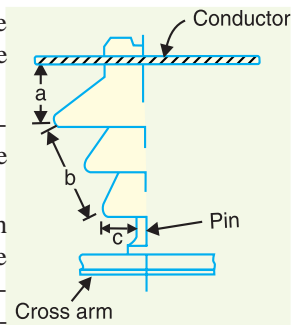

Fig. 8.6

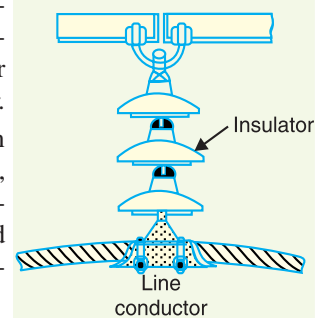

Fig. 8.7



Pin type insulator



Suspension insulator

It is desirable that the value of safety factor is high so that flash-over takes place before the insulator gets punctured. For pin type insulators, the value of safety factor is about 10.

2 Suspension type insulators. The cost of pin type insulator increases rapidly as the working voltage is increased. Therefore, this type of insulator is not economical beyond 33 kV. For high voltages (>33 kV), it is a usual practice to use suspension type insulators shown in Fig. 8.7. They

* The insulator is generally dry and its surfaces have proper insulating properties. Therefore, arc can only occur through air gap between conductor and insulator pin.

consist of a number of porcelain discs connected in series by metal links in the form of a string. The conductor is suspended at the bottom end of this string while the other end of the string is secured to the cross-arm of the tower. Each unit or disc is designed for low voltage, say 11 kV. The number of discs in series would obviously depend upon the working voltage. For instance, if the working voltage is 66 kV, then six discs in series will be provided on the string.

Advantages

- (i) Suspension type insulators are cheaper than pin type insulators for voltages beyond 33 kV.
- (ii) Each unit or disc of suspension type insulator is designed for low voltage, usually 11 kV. Depending upon the working voltage, the desired number of discs can be connected in series.
- (iii) If any one disc is damaged, the whole string does not become useless because the damaged disc can be replaced by the sound one.
- (iv) The suspension arrangement provides greater flexibility to the line. The connection at the cross arm is such that insulator string is free to swing in any direction and can take up the position where mechanical stresses are minimum.
- (v) In case of increased demand on the transmission line, it is found more satisfactory to supply the greater demand by raising the line voltage than to provide another set of conductors. The additional insulation required for the raised voltage can be easily obtained in the suspension arrangement by adding the desired number of discs.
- (vi) The suspension type insulators are generally used with steel towers. As the conductors run below the earthed cross-arm of the tower, therefore, this arrangement provides partial protection from lightning.

3. Strain insulators. When there is a dead end of the line or there is corner or sharp curve, the line is subjected to greater tension. In order to relieve the line of excessive tension, strain insulators are used. For low voltage lines (< 11 kV), shackle insulators are used as strain insulators. However, for high voltage transmission lines, strain insulator consists of an assembly of suspension insulators as shown in Fig. 8.8. The discs of strain insulators are used in the vertical plane. When the tension in lines is exceedingly high, as at long river spans, two or more strings are used in parallel.

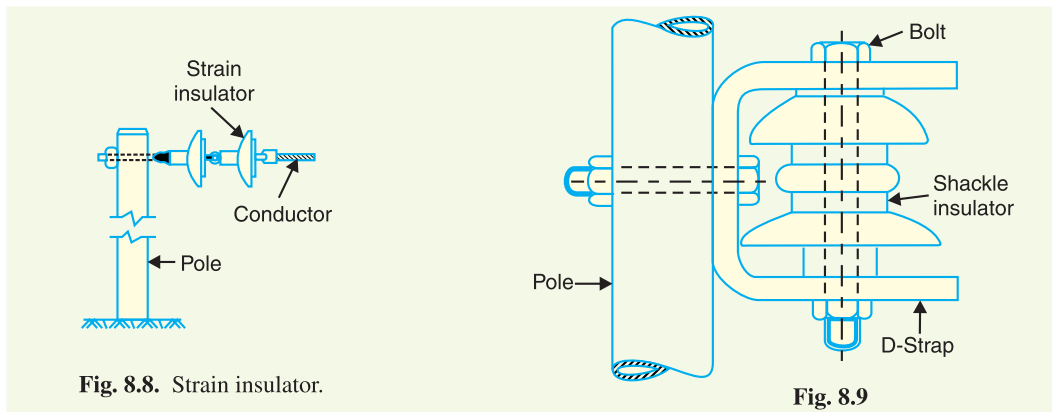

4. Shackle insulators. In early days, the shackle insulators were used as strain insulators. But now a days, they are frequently used for low voltage distribution lines. Such insulators can be used either in a horizontal position or in a vertical position. They can be directly fixed to the pole with a bolt or to the cross arm. Fig. 8.9 shows a shackle insulator fixed to the pole. The conductor in the groove is fixed with a soft binding wire.

8.6 Potential Distribution over Suspension Insulator String

A string of suspension insulators consists of a number of porcelain discs connected in series through metallic links. Fig. 8.10 (i) shows 3-disc string of suspension insulators. The porcelain portion of each disc is in between two metal links. Therefore, each disc forms a capacitor C as shown in Fig. 8.10 (ii). This is known as *mutual capacitance* or *self-capacitance*. If there were mutual capacitance alone, then charging current would have been the same through all the discs and consequently voltage across each unit would have been the same *i.e.*, $V/3$ as shown in Fig. 8.10 (ii). However, in actual practice, capacitance also exists between metal fitting of each disc and tower or earth. This is known as *shunt capacitance* C_1 . Due to shunt capacitance, charging current is not the same through all the discs of the string [See Fig. 8.10 (iii)]. Therefore, voltage across each disc will be different. Obviously, the disc nearest to the line conductor will have the maximum* voltage. Thus referring to Fig. 8.10 (iii), V_3 will be much more than V_2 or V_1 .

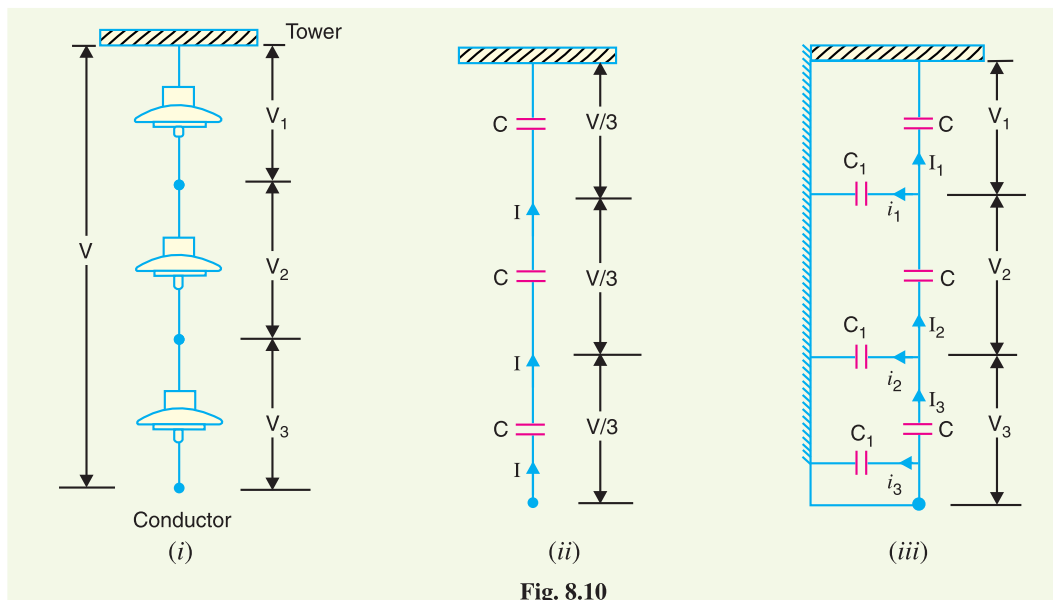

Fig. 8.10

The following points may be noted regarding the potential distribution over a string of suspension insulators :

- (i) The voltage impressed on a string of suspension insulators does not distribute itself uniformly across the individual discs due to the presence of shunt capacitance.
- (ii) The disc nearest to the conductor has maximum voltage across it. As we move towards the cross-arm, the voltage across each disc goes on decreasing.
- (iii) The unit nearest to the conductor is under maximum electrical stress and is likely to be punctured. Therefore, means must be provided to equalise the potential across each unit. This is fully discussed in Art. 8.8.
- (iv) If the voltage impressed across the string were d.c., then voltage across each unit would be the same. It is because insulator capacitances are ineffective for d.c.

8.7 String Efficiency

As stated above, the voltage applied across the string of suspension insulators is not uniformly distributed across various units or discs. The disc nearest to the conductor has much higher potential than the other discs. This unequal potential distribution is undesirable and is usually expressed in

* Because charging current through the string has the maximum value at the disc nearest to the conductor.

terms of string efficiency.

The ratio of voltage across the whole string to the product of number of discs and the voltage across the disc nearest to the conductor is known as **string efficiency** i.e.,

$$\text{String efficiency} = \frac{\text{Voltage across the string}}{n \times \text{Voltage across disc nearest to conductor}}$$

where

$$n = \text{number of discs in the string.}$$

String efficiency is an important consideration since it decides the potential distribution along the string. The greater the string efficiency, the more uniform is the voltage distribution. Thus 100% string efficiency is an ideal case for which the voltage across each disc will be exactly the same. Although it is impossible to achieve 100% string efficiency, yet efforts should be made to improve it as close to this value as possible.

Mathematical expression. Fig. 8.11 shows the equivalent circuit for a 3-disc string. Let us suppose that self capacitance of each disc is C . Let us further assume that shunt capacitance C_1 is some fraction K of self-capacitance i.e., $C_1 = KC$. Starting from the cross-arm or tower, the voltage across each unit is V_1, V_2 and V_3 respectively as shown.

Applying Kirchoff's current law to node A, we get,

$$I_2 = I_1 + i_1$$

or

$$V_2 \omega C^* = V_1 \omega C + V_1 \omega C_1$$

or

$$V_2 \omega C = V_1 \omega C + V_1 \omega KC$$

∴

$$V_2 = V_1 (1 + K)$$

Applying Kirchoff's current law to node B, we get,

$$I_3 = I_2 + i_2$$

or

$$V_3 \omega C = V_2 \omega C + (V_1 + V_2) \omega C_1 \dagger$$

or

$$V_3 \omega C = V_2 \omega C + (V_1 + V_2) \omega KC$$

or

$$V_3 = V_2 + (V_1 + V_2)K$$

$$= KV_1 + V_2 (1 + K)$$

$$= KV_1 + V_1 (1 + K)^2$$

$$= V_1 [K + (1 + K)^2]$$

∴

$$V_3 = V_1 [1 + 3K + K^2] \quad \dots(ii)$$

Voltage between conductor and earth (i.e., tower) is

$$V = V_1 + V_2 + V_3$$

$$= V_1 + V_1(1 + K) + V_1 (1 + 3K + K^2)$$

$$= V_1 (3 + 4K + K^2)$$

∴

$$V = V_1(1 + K) (3 + K) \quad \dots(iii)$$

From expressions (i), (ii) and (iii), we get,

$$\frac{V_1}{1} = \frac{V_2}{1 + K} = \frac{V_3}{1 + 3K + K^2} = \frac{V}{(1 + K)(3 + K)} \quad \dots(iv)$$

$$\therefore \text{Voltage across top unit, } V_1 = \frac{V}{(1 + K)(3 + K)}$$

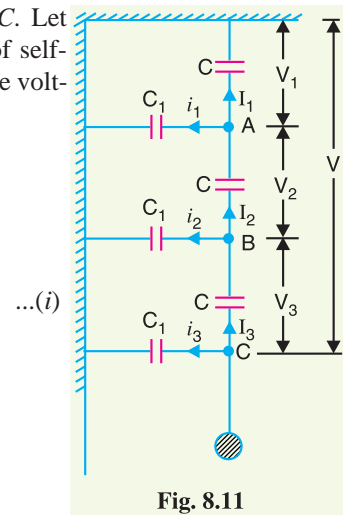

Fig. 8.11

$$[\because V_2 = V_1 (1 + K)]$$

* Note that current through capacitor = $\frac{\text{Voltage}}{\text{Capacitive reactance}}$

† Voltage across second shunt capacitance C_1 from top = $V_1 + V_2$. It is because one point of it is connected to B and the other point to the tower.

Voltage across second unit from top, $V_2 = V_1 (1 + K)$

Voltage across third unit from top, $V_3 = V_1 (1 + 3K + K^2)$

$$\begin{aligned} \text{\%age String efficiency} &= \frac{\text{Voltage across string}}{n \times \text{Voltage across disc nearest to conductor}} \times 100 \\ &= \frac{V}{3 \times V_3} \times 100 \end{aligned}$$

The following points may be noted from the above mathematical analysis :

- (i) If $K = 0.2$ (Say), then from exp. (iv), we get, $V_2 = 1.2 V_1$ and $V_3 = 1.64 V_1$. This clearly shows that disc nearest to the conductor has maximum voltage across it; the voltage across other discs decreasing progressively as the cross-arm is approached.
- (ii) The greater the value of $K (= C_1/C)$, the more non-uniform is the potential across the discs and lesser is the string efficiency.
- (iii) The inequality in voltage distribution increases with the increase of number of discs in the string. Therefore, shorter string has more efficiency than the larger one.

8.8 Methods of Improving String Efficiency

It has been seen above that potential distribution in a string of suspension insulators is not uniform. The maximum voltage appears across the insulator nearest to the line conductor and decreases progressively as the cross-arm is approached. If the insulation of the highest stressed insulator (*i.e.* nearest to conductor) breaks down or flash over takes place, the breakdown of other units will take place in succession. This necessitates to equalise the potential across the various units of the string *i.e.* to improve the string efficiency. The various methods for this purpose are :

- (i) **By using longer cross-arms.** The value of string efficiency depends upon the value of K *i.e.*, ratio of shunt capacitance to mutual capacitance. The lesser the value of K , the greater is the string efficiency and more uniform is the voltage distribution. The value of K can be decreased by reducing the shunt capacitance. In order to reduce shunt capacitance, the distance of conductor from tower must be increased *i.e.*, longer cross-arms should be used. However, limitations of cost and strength of tower do not allow the use of very long cross-arms. In practice, $K = 0.1$ is the limit that can be achieved by this method.
- (ii) **By grading the insulators.** In this method, insulators of different dimensions are so chosen that each has a different capacitance. The insulators are capacitance graded *i.e.* they are assembled in the string in such a way that the top unit has the minimum capacitance, increasing progressively as the bottom unit (*i.e.*, nearest to conductor) is reached. Since voltage is inversely proportional to capacitance, this method tends to equalise the potential distribution across the units in the string. This method has the disadvantage that a large number of different-sized insulators are required. However, good results can be obtained by using standard insulators for most of the string and larger units for that near to the line conductor.
- (iii) **By using a guard ring.** The potential across each unit in a string can be equalised by using a guard ring which is a metal ring electrically connected to the conductor and surrounding the bottom insulator as shown in the Fig. 8.13. The guard ring introduces capacitance be-

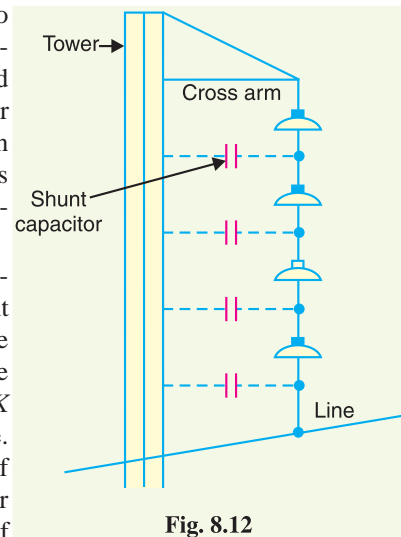

Fig. 8.12

tween metal fittings and the line conductor. The guard ring is contoured in such a way that shunt capacitance currents i_1, i_2 etc. are equal to metal fitting line capacitance currents i'_1, i'_2 etc. The result is that same charging current I flows through each unit of string. Consequently, there will be uniform potential distribution across the units.

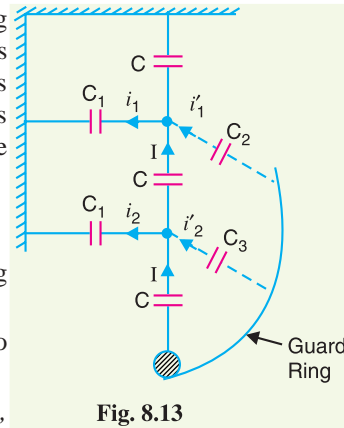

Fig. 8.13

8.9 Important Points

While solving problems relating to string efficiency, the following points must be kept in mind:

(i) The maximum voltage appears across the disc nearest to the conductor (i.e., line conductor).

(ii) The voltage across the string is equal to phase voltage i.e.,

$$\text{Voltage across string} = \text{Voltage between line and earth} = \text{Phase Voltage}$$

(iii) Line Voltage = $\sqrt{3} \times$ Voltage across string

Example 8.1. In a 33 kV overhead line, there are three units in the string of insulators. If the capacitance between each insulator pin and earth is 11% of self-capacitance of each insulator, find (i) the distribution of voltage over 3 insulators and (ii) string efficiency.

Solution. Fig. 8.14. shows the equivalent circuit of string insulators. Let V_1, V_2 and V_3 be the voltage across top, middle and bottom unit respectively. If C is the self-capacitance of each unit, then KC will be the shunt capacitance.

$$K = \frac{\text{Shunt Capacitance}}{\text{Self-capacitance}} = 0.11$$

$$\text{Voltage across string, } V = 33/\sqrt{3} = 19.05 \text{ kV}$$

At Junction A

$$I_2 = I_1 + i_1$$

or

$$V_2 \omega C = V_1 \omega C + V_1 K \omega C$$

or

$$V_2 = V_1 (1 + K) = V_1 (1 + 0.11)$$

or

$$V_2 = 1.11 V_1$$

At Junction B

$$I_3 = I_2 + i_2$$

or

$$V_3 \omega C = V_2 \omega C + (V_1 + V_2) K \omega C$$

or

$$V_3 = V_2 + (V_1 + V_2) K$$

$$= 1.11 V_1 + (V_1 + 1.11 V_1) 0.11$$

∴

$$V_3 = 1.342 V_1$$

(i) Voltage across the whole string is

$$V = V_1 + V_2 + V_3 = V_1 + 1.11 V_1 + 1.342 V_1 = 3.452 V_1$$

or

$$19.05 = 3.452 V_1$$

$$\therefore \text{Voltage across top unit, } V_1 = 19.05/3.452 = \mathbf{5.52 \text{ kV}}$$

$$\text{Voltage across middle unit, } V_2 = 1.11 V_1 = 1.11 \times 5.52 = \mathbf{6.13 \text{ kV}}$$

$$\text{Voltage across bottom unit, } V_3 = 1.342 V_1 = 1.342 \times 5.52 = \mathbf{7.4 \text{ kV}}$$

(ii) String efficiency = $\frac{\text{Voltage across string}}{\text{No. of insulators} \times V_3} \times 100 = \frac{19.05}{3 \times 7.4} \times 100 = \mathbf{85.8\%}$

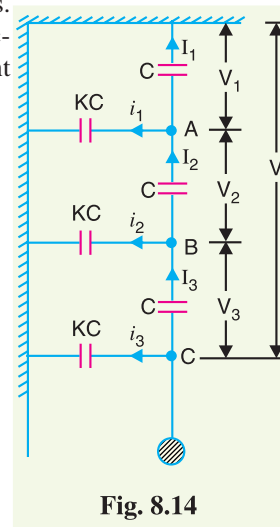

Fig. 8.14

Example 8.2. A 3-phase transmission line is being supported by three disc insulators. The potentials across top unit (i.e., near to the tower) and middle unit are 8 kV and 11 kV respectively. Calculate (i) the ratio of capacitance between pin and earth to the self-capacitance of each unit (ii) the line voltage and (iii) string efficiency.

Solution. The equivalent circuit of string insulators is the same as shown in Fig. 8.14. It is given that $V_1 = 8$ kV and $V_2 = 11$ kV.

(i) Let K be the ratio of capacitance between pin and earth to self capacitance. If C farad is the self capacitance of each unit, then capacitance between pin and earth = KC .

Applying Kirchoff's current law to Junction A,

$$I_2 = I_1 + i_1$$

$$\text{or } V_2 \omega C = V_1 \omega C + V_1 K \omega C$$

$$\text{or } V_2 = V_1 (1 + K)$$

$$\therefore K = \frac{V_2 - V_1}{V_1} = \frac{11 - 8}{8} = 0.375$$

(ii) Applying Kirchoff's current law to Junction B,

$$I_3 = I_2 + i_2$$

$$\text{or } V_3 \omega C = V_2 \omega C + (V_1 + V_2) K \omega C$$

$$\text{or } V_3 = V_2 + (V_1 + V_2) K = 11 + (8 + 11) \times 0.375 = 18.12 \text{ kV}$$

$$\text{Voltage between line and earth} = V_1 + V_2 + V_3 = 8 + 11 + 18.12 = 37.12 \text{ kV}$$

$$\therefore \text{Line Voltage} = \sqrt{3} \times 37.12 = 64.28 \text{ kV}$$

$$\text{(iii) String efficiency} = \frac{\text{Voltage across string}}{\text{No. of insulators} \times V_3} \times 100 = \frac{37.12}{3 \times 18.12} \times 100 = 68.28\%$$

Example 8.3. Each line of a 3-phase system is suspended by a string of 3 similar insulators. If the voltage across the line unit is 17.5 kV, calculate the line to neutral voltage. Assume that the shunt capacitance between each insulator and earth is 1/8th of the capacitance of the insulator itself. Also find the string efficiency.

Solution. Fig. 8-15 shows the equivalent circuit of string insulators. If C is the self capacitance of each unit, then KC will be the shunt capacitance where $K = 1/8 = 0.125$.

$$\text{Voltage across line unit, } V_3 = 17.5 \text{ kV}$$

At Junction A

$$I_2 = I_1 + i_1$$

$$V_2 \omega C = V_1 \omega C + V_1 K \omega C$$

$$\text{or } V_2 = V_1 (1 + K) = V_1 (1 + 0.125)$$

$$\therefore V_2 = 1.125 V_1$$

At Junction B

$$I_3 = I_2 + i_2$$

$$\text{or } V_3 \omega C = V_2 \omega C + (V_1 + V_2) K \omega C$$

$$\text{or } V_3 = V_2 + (V_1 + V_2) K$$

$$= 1.125 V_1 + (V_1 + 1.125 V_1) \times 0.125$$

$$\therefore V_3 = 1.39 V_1$$

$$\begin{aligned} \text{Voltage across top unit, } V_1 &= V_3 / 1.39 = 17.5 / 1.39 \\ &= 12.59 \text{ kV} \end{aligned}$$

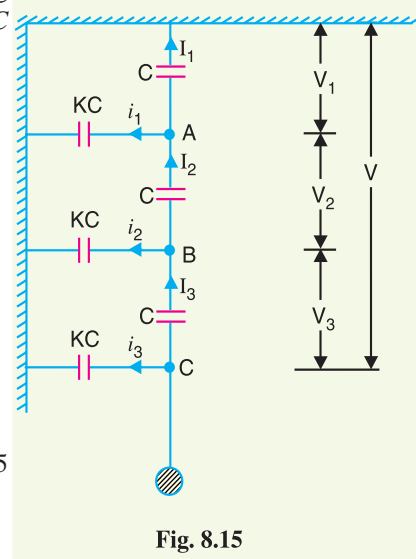

Fig. 8.15

Voltage across middle unit, $V_2 = 1.125 V_1 = 1.125 \times 12.59 = 14.16 \text{ kV}$

\therefore Voltage between line and earth (i.e., line to neutral)

$$= V_1 + V_2 + V_3 = 12.59 + 14.16 + 17.5 = \mathbf{44.25 \text{ kV}}$$

$$\text{String efficiency} = \frac{44.25}{3 \times 17.5} \times 100 = \mathbf{84.28\%}$$

Example 8.4. The three bus-bar conductors in an outdoor substation are supported by units of post type insulators. Each unit consists of a stack of 3 pin type insulators fixed one on the top of the other. The voltage across the lowest insulator is 13.1 kV and that across the next unit is 11 kV. Find the bus-bar voltage of the station.

Solution. The equivalent circuit of insulators is the same as shown in Fig. 8.15. It is given that $V_3 = 13.1 \text{ kV}$ and $V_2 = 11 \text{ kV}$. Let K be the ratio of shunt capacitance to self capacitance of each unit. Applying Kirchhoff's current law to Junctions A and B , we can easily derive the following equations (See example 8.3) :

$$V_2 = V_1 (1 + K)$$

$$\text{or} \quad V_1 = \frac{V_2}{1 + K} \quad \dots(i)$$

$$\text{and} \quad V_3 = V_2 + (V_1 + V_2) K \quad \dots(ii)$$

Putting the value of $V_1 = V_2/(1 + K)$ in eq. (ii), we get,

$$V_3 = V_2 + \left[\frac{V_2}{1 + K} + V_2 \right] K$$

$$\text{or} \quad V_3 (1 + K) = V_2 (1 + K) + [V_2 + V_2 (1 + K)] K$$

$$= V_2 [(1 + K) + K + (K + K^2)]$$

$$= V_2 (1 + 3K + K^2)$$

$$\therefore \quad 13.1 (1 + K) = 11[1 + 3K + K^2]$$

$$\text{or} \quad 11K^2 + 19.9K - 2.1 = 0$$

Solving this equation, we get, $K = 0.1$.

$$\therefore \quad V_1 = \frac{V_2}{1 + K} = \frac{11}{1 + 0.1} = 10 \text{ kV}$$

Voltage between line and earth = $V_1 + V_2 + V_3 = 10 + 11 + 13.1 = 34.1 \text{ kV}$

\therefore Voltage between bus-bars (i.e., line voltage)

$$= 34.1 \times \sqrt{3} = \mathbf{59 \text{ kV}}$$

Example 8.5. An insulator string consists of three units, each having a safe working voltage of 15 kV. The ratio of self-capacitance to shunt capacitance of each unit is 8 : 1. Find the maximum safe working voltage of the string. Also find the string efficiency.

Solution. The equivalent circuit of string insulators is the same as shown in Fig. 8.15. The maximum voltage will appear across the lowest unit in the string.

$$\therefore \quad V_3 = 15 \text{ kV} ; \quad K = 1/8 = 0.125$$

Applying Kirchhoff's current law to junction A , we get,

$$V_2 = V_1 (1 + K)$$

$$\text{or} \quad V_1 = V_2/(1 + K) = V_2/(1 + 0.125) = 0.89 V_2 \quad \dots(i)$$

Applying Kirchhoff's current law to Junction B , we get,

$$V_3 = V_2 + (V_1 + V_2) K = V_2 + (0.89 V_2 + V_2) \times 0.125$$

$$\begin{aligned} \therefore V_3 &= 1.236 V_2 && \dots(ii) \\ \therefore \text{Voltage across middle unit, } V_2 &= V_3/1.236 = 15/1.236 = 12.13 \text{ kV} \\ \text{Voltage across top unit, } V_1 &= 0.89 V_2 = 0.89 \times 12.13 = 10.79 \text{ kV} \\ \text{Voltage across the String} &= V_1 + V_2 + V_3 = 10.79 + 12.13 + 15 = \mathbf{37.92 \text{ kV}} \\ \text{String efficiency} &= \frac{37.92}{3 \times 15} \times 100 = \mathbf{84.26 \%} \end{aligned}$$

Example 8.6. A string of 4 insulators has a self-capacitance equal to 10 times the pin to earth capacitance. Find (i) the voltage distribution across various units expressed as a percentage of total voltage across the string and (ii) string efficiency.

Solution. When the number of insulators in a string exceeds 3, the nodal equation method becomes laborious. Under such circumstances, there is a simple method to solve the problem. In this method*, shunt capacitance (C_1) and self capacitance (C) of each insulator are represented by their equivalent reactances. As it is only the ratio of capacitances which determines the voltage distribution, therefore, the problem can be simplified by assigning unity value to X_C i.e., assuming $X_C = 1 \Omega$. If ratio of $C/C_1 = 10$, then we have $X_C = 1 \Omega$ and $X_{C1} = 10 \Omega$.

(i) Suppose $X_C = 1 \Omega$. As the ratio of self-capacitance to shunt capacitance (i.e., C/C_1) is 10, therefore, $X_{C1} = 10 \Omega$ as shown in Fig. 8-16 (i). Suppose that potential V across the string is such that 1 A current flows in the top insulator. Now the potential across each insulator can be easily determined. Thus :

$$\begin{aligned} \text{Voltage across top unit, } V_1 &= 1 \Omega \times 1 \text{ A} = 1 \text{ volt} \\ \text{Voltage across **2nd unit, } V_2 &= 1 \Omega \times 1.1 \text{ A} = 1.1 \text{ volts} \\ \text{Voltage across †3rd unit, } V_3 &= 1 \Omega \times 1.31 \text{ A} = 1.31 \text{ volts} \\ \text{Voltage across 4th unit, } V_4 &= 1 \Omega \times 1.65 \text{ A} = 1.65 \text{ volts} \\ \text{Voltage obtained across the string, } V &= 1 + 1.1 + 1.31 + 1.65 = 5.06 \text{ volts} \end{aligned}$$

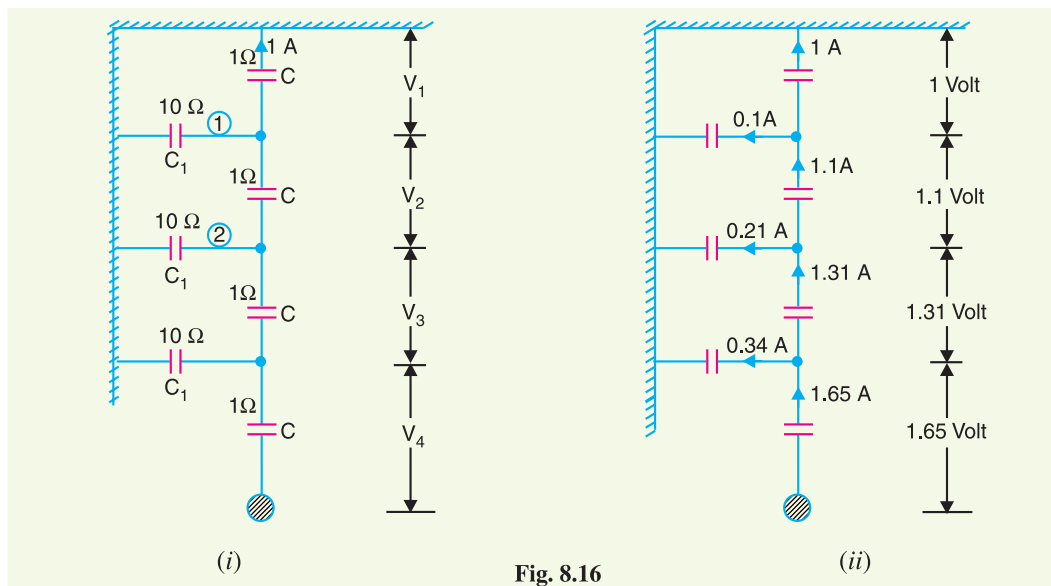

Fig. 8.16

* This method is equally applicable for a string having 3 or less than 3 insulators.

** Current through first shunt capacitance [marked 1, see Fig. 8-16] is $V_1/10 = 1/10 = 0.1 \text{ A}$. Therefore, the current through second unit from top is $1 + 0.1 = 1.1 \text{ A}$ and voltage across it is $1 \Omega \times 1.1 \text{ A} = 1.1 \text{ volts}$.

† Current through second shunt capacitance [marked 2 in Fig. 8-16] is $(V_1 + V_2)/10 = (1 + 1.1)/10 = 0.21 \text{ A}$. Therefore, current thro' 3rd unit from top = $1.1 + 0.21 = 1.31 \text{ A}$ and voltage across it is $1 \Omega \times 1.31 \text{ A} = 1.31 \text{ volts}$.

The voltage across each unit expressed as a percentage of V (i.e., 5.06 volts) becomes :

- Top unit = $(1/5.06) \times 100 = 19.76\%$
- Second from top = $(1.1/5.06) \times 100 = 21.74\%$
- Third from top = $(1.31/5.06) \times 100 = 25.9\%$
- Fourth from top = $(1.65/5.06) \times 100 = 32.6\%$

(ii) String efficiency = $\frac{V}{4 \times V_4} \times 100 = \frac{5.06}{4 \times 1.65} \times 100 = 76.6\%$

Example 8.7. A string of 5 insulators is connected across a 100 kV line. If the capacitance of each disc to earth is 0.1 of the capacitance of the insulator, calculate (i) the distribution of voltage on the insulator discs and (ii) the string efficiency.

Solution. Suppose $X_C = 1 \Omega$. As the ratio of self capacitance to shunt capacitance is 10, therefore, $X_{C1} = 10 \Omega$ as shown in Fig. 8.17 (i). Suppose that potential V across the string is such that 1A current flows in the top insulator. Then potential across each insulator will be as shown in Fig. 8.17 (ii).

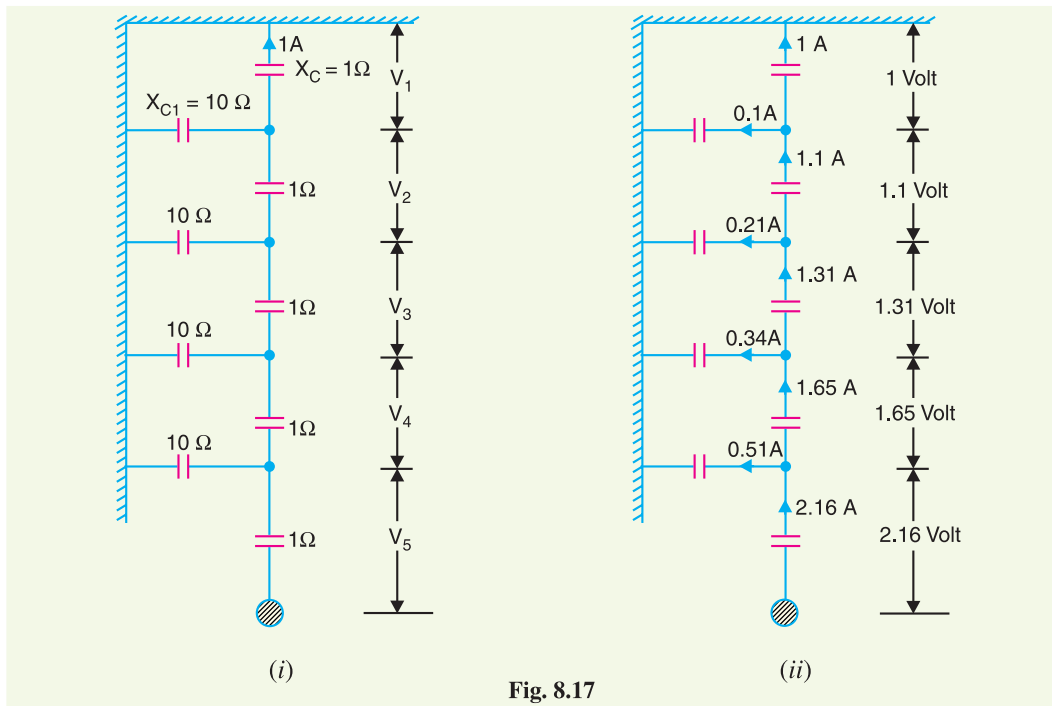

Fig. 8.17

The value obtained for $V = 1 + 1.1 + 1.31 + 1.65 + 2.16 = 7.22$ volts and starting from top, the percentage of V (i.e., 7.22 volts) across various units are :

*13.8 %, 15.2 %, 18.2 %, 22.8 % and 30%

Voltage across string = $100/\sqrt{3} = 57.7$ kV

(i) Voltage across top insulator, $V_1 = 0.138 \times 57.7 = 7.96$ kV

Voltage across 2nd from top, $V_2 = 0.152 \times 57.7 = 8.77$ kV

* % age of V (i.e., 7.22 volts) across top unit = $\frac{1}{7.22} \times 100 = 13.8\%$

% age of V across 2nd from top = $\frac{1.1}{7.22} \times 100 = 15.2\%$

Voltage across 3rd from top, $V_3 = 0.182 \times 57.7 = 10.5 \text{ kV}$

Voltage across 4th from top, $V_4 = 0.228 \times 57.7 = 13.16 \text{ kV}$

Voltage across 5th from top, $V_5 = 0.3 \times 57.7 = 17.3 \text{ kV}$

(ii) String efficiency = $\frac{57.7}{5 \times 17.3} \times 100 = 66.7\%$

Example 8.8. Each conductor of a 3-phase high-voltage transmission line is suspended by a string of 4 suspension type disc insulators. If the potential difference across the second unit from top is 13.2 kV and across the third from top is 18 kV, determine the voltage between conductors.

Solution. Suppose $X_C = 1 \Omega$. If K is the ratio of shunt-capacitance to self-capacitance, then $X_{C1} = 1/K$ ohms as shown in Fig. 8.18 (i). Suppose voltage across string is such that current in top insulator disc is 1 A. Then voltage across each insulator can be easily determined [see Fig. 8.18 (ii)]. Thus the voltage across first shunt capacitance from top is 1 volt and its reactance is $1/K$ ohms. Therefore, current through it is K ampere. Hence current through second insulator from top is $(1 + K)$ amperes and voltage across it is $(1 + K) \times 1 = (1 + K)$ volts.

Referring to Fig. 8.18 (ii), we have,

$$V_2/V_1 = (1 + K)/1$$

or $V_2 = V_1 (1 + K)$... (i)

Also $V_3/V_1 = (1 + 3K + K^2)/1$

$\therefore V_3 = V_1 (1 + 3K + K^2)$... (ii)

Dividing (ii) by (i), we get,

$$\frac{V_3}{V_2} = \frac{1 + 3K + K^2}{1 + K}$$

It is given that $V_3 = 18 \text{ kV}$ and $V_2 = 13.2 \text{ kV}$

$\therefore \frac{18}{13.2} = \frac{1 + 3K + K^2}{1 + K}$

or $13.2 K^2 + 21.6 K - 4.8 = 0$

Solving this equation, we get, $K = 0.2$.

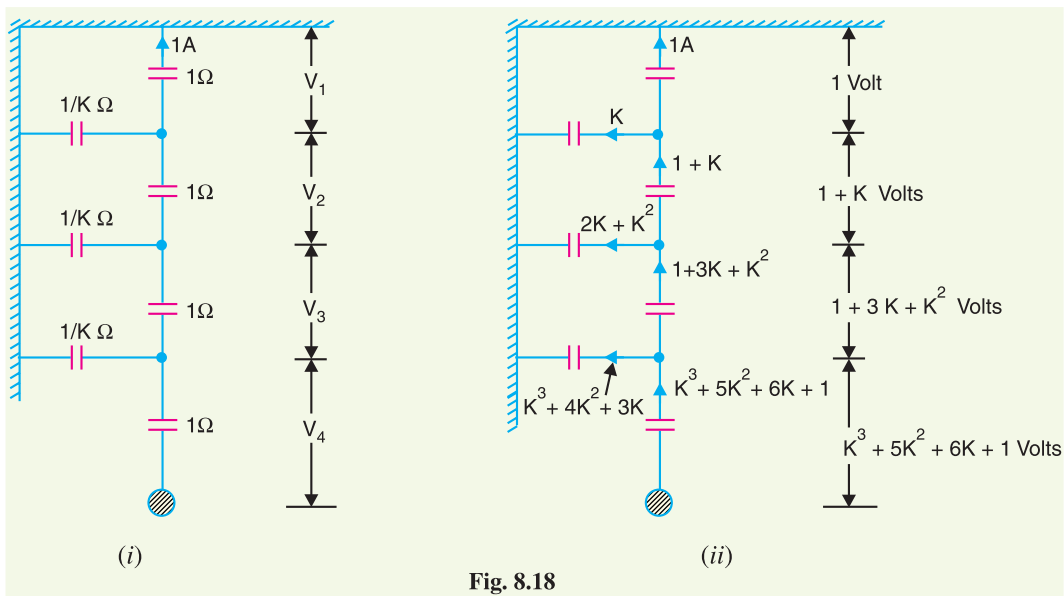

$$\begin{aligned} \therefore V_1 &= V_2/(1 + K) = 13.2/1.2 = 11 \text{ kV} \\ V_4 &= V_1(1 + K^3 + 5K^2 + 6K) = 11(1 + 0.008 + 0.2 + 1.2) = 26.49 \text{ kV} \end{aligned}$$

Voltage between line and earth (*i.e.*, phase voltage)

$$\begin{aligned} &= V_1 + V_2 + V_3 + V_4 \\ &= 11 + 13.2 + 18 + 26.49 = 68.69 \text{ kV} \end{aligned}$$

Voltage between conductors (*i.e.*, line voltage)

$$= 68.69 \times \sqrt{3} = \mathbf{119 \text{ kV}}$$

Example 8.9. A string of four insulators has a self-capacitance equal to 5 times pin to earth capacitance. Find (i) the voltage distribution across various units as a percentage of total voltage across the string and (ii) string efficiency.

Solution. The ratio of self-capacitance (C) to pin-earth capacitance (C_1) is $C/C_1 = 5$. Suppose $X_C = 1 \Omega$. Then $X_{C1} = 5 \Omega$. Suppose the voltage V across string is such that current in the top insulator is 1A as shown in Fig. 8.19 (i). The potential across various insulators will be as shown in Fig. 8.19 (ii).

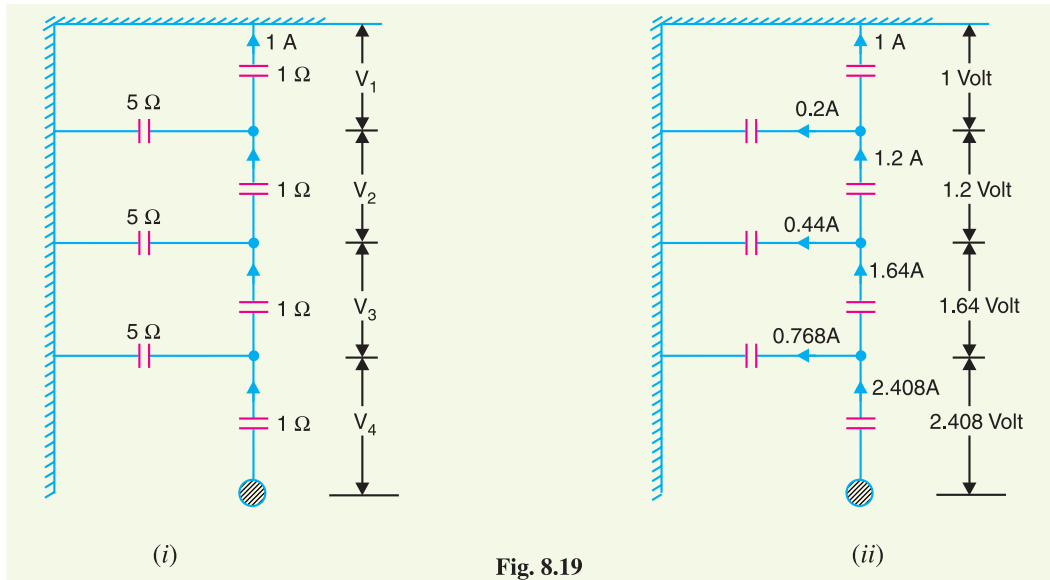

Fig. 8.19

The voltage obtained across the string is given by ;

$$V = 1 + 1.2 + 1.64 + 2.408 = 6.248 \text{ volts}$$

(i) The voltage across each unit expressed as a percentage of V (*i.e.*, 6.248 volts) is given by :

$$\begin{aligned} \text{Top Unit} &= (1/6.248) \times 100 = \mathbf{16\%} \\ \text{Second from top} &= (1.2/6.248) \times 100 = \mathbf{19.2\%} \\ \text{Third from top} &= (1.64/6.248) \times 100 = \mathbf{26.3\%} \\ \text{Fourth from top} &= (2.408/6.248) \times 100 = \mathbf{38.5\%} \end{aligned}$$

$$(ii) \text{ String efficiency} = \frac{6.248}{4 \times 2.408} \times 100 = \mathbf{64.86\%}$$

Example 8.10. The self capacitance of each unit in a string of three suspension insulators is C . The shunting capacitance of the connecting metal work of each insulator to earth is $0.15 C$ while for line it is $0.1 C$. Calculate (i) the voltage across each insulator as a percentage of the line voltage to earth and (ii) string efficiency.

Solution. In an actual string of insulators, three capacitances exist viz., self-capacitance of each insulator, shunt capacitance and capacitance of each unit to line as shown in Fig. 8.20 (i). However, capacitance of each unit to line is very small and is usually neglected. Fig. 8.20 (ii) shows the equivalent circuit of string insulators.

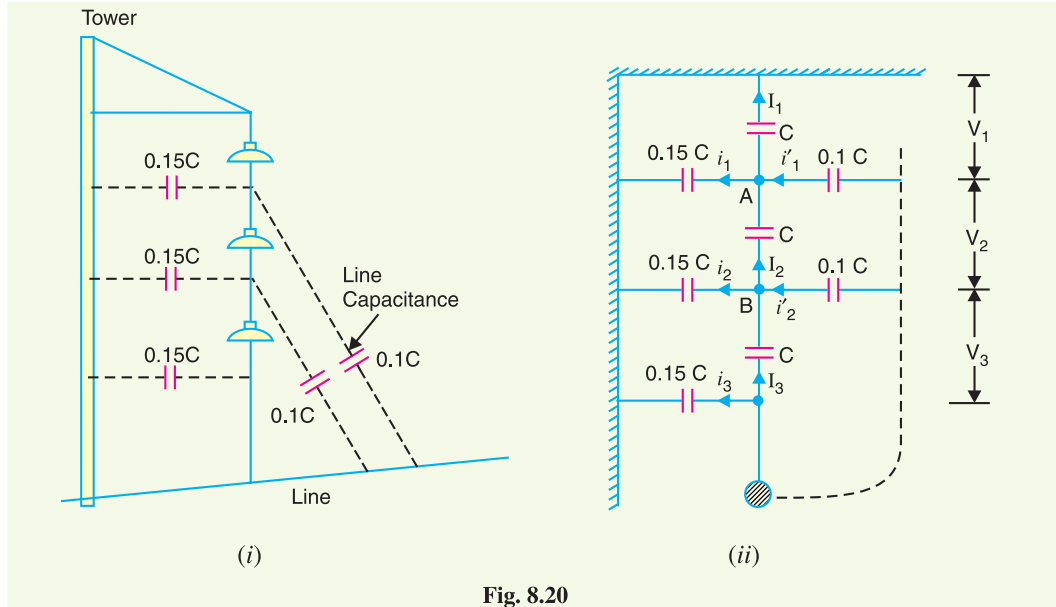

Fig. 8.20

At Junction A

$$I_2 + i'_1 = I_1 + i_1$$

$$\text{or } V_2 \omega C + (V_2 + V_3) 0.1 \omega C = V_1 \omega C + 0.15 C V_1 \omega$$

$$\text{or } 0.1 V_3 = 1.15 V_1 - 1.1 V_2$$

$$\text{or } V_3 = 11.5 V_1 - 11 V_2 \quad \dots(i)$$

At Junction B

$$I_3 + i'_2 = I_2 + i_2$$

$$\text{or } V_3 \omega C + V_3 \times 0.1 C \times \omega = V_2 \omega C + (V_1 + V_2) \omega \times 0.15 C$$

$$\text{or } 1.1 V_3 = 1.15 V_2 + 0.15 V_1 \quad \dots(ii)$$

Putting the value of V_3 from exp. (i). into exp. (ii), we get,

$$1.1 (11.5 V_1 - 11 V_2) = 1.15 V_2 + 0.15 V_1$$

$$\text{or } 13.25 V_2 = 12.5 V_1$$

$$\text{or } V_2 = \frac{12.5}{13.25} V_1 \quad \dots(iii)$$

Putting the value of V_2 from exp. (iii) into exp. (i), we get,

$$V_3 = 11.5 V_1 - 11 \left(\frac{12.5 V_1}{13.25} \right) = \left(\frac{14.8}{13.25} \right) V_1$$

Now voltage between conductor and earth is

$$V = V_1 + V_2 + V_3 = V_1 \left(1 + \frac{12.5}{13.25} + \frac{14.8}{13.25} \right) = \left(\frac{40.55 V_1}{13.25} \right) \text{ volts}$$

\therefore

$$V_1 = 13.25 V / 40.55 = 0.326 V \text{ volts}$$

$$V_2 = 12.5 \times 0.326 V / 13.25 = 0.307 V \text{ volts}$$

$$V_3 = 14.8 \times 0.326 V / 13.25 = 0.364 V \text{ volts}$$

(i) The voltage across each unit expressed as a percentage of V becomes:

Top unit $= V_1 \times 100/V = 0.326 \times 100 = 32.6\%$
 Second from top $= V_2 \times 100/V = 0.307 \times 100 = 30.7\%$
 Third from top $= V_3 \times 100/V = 0.364 \times 100 = 36.4\%$

(ii) String efficiency $= \frac{V}{3 \times 0.364 V} \times 100 = 91.5\%$

Example 8.11. Each line of a 3-phase system is suspended by a string of 3 identical insulators of self-capacitance C farad. The shunt capacitance of connecting metal work of each insulator is $0.2 C$ to earth and $0.1 C$ to line. Calculate the string efficiency of the system if a guard ring increases the capacitance to the line of metal work of the lowest insulator to $0.3 C$.

Solution. The capacitance between each unit and line is artificially increased by using a guard ring as shown in Fig. 8.21. This arrangement tends to equalise the potential across various units and hence leads to improved string efficiency. It is given that with the use of guard ring, capacitance of the insulator link-pin to the line of the lowest unit is increased from $0.1 C$ to $0.3 C$.

At Junction A

$$I_2 + i'_1 = I_1 + i_1$$

or $V_2 \omega C + (V_2 + V_3) \omega \times 0.1 C$
 $= V_1 \omega C + V_1 \times 0.2 C \omega$
 $V_3 = 12 V_1 - 11 V_2 \quad \dots(i)$

At Junction B

$$I_3 + i'_2 = I_2 + i_2$$

or $V_3 \omega C + V_3 \times 0.3 C \times \omega = V_2 \omega C + (V_1 + V_2) \omega \times 0.2 C$
 or $1.3 V_3 = 1.2 V_2 + 0.2 V_1 \quad \dots(ii)$

Substituting the value of V_3 from exp. (i) into exp. (ii), we get,

$$1.3 (12 V_1 - 11 V_2) = 1.2 V_2 + 0.2 V_1$$

or $15.5 V_2 = 15.4 V_1$
 $\therefore V_2 = 15.4 V_1 / 15.5 = 0.993 V_1 \quad \dots(iii)$

Substituting the value of V_2 from exp. (iii) into exp. (i), we get,

$$V_3 = 12 V_1 - 11 \times 0.993 V_1 = 1.077 V_1$$

Voltage between conductor and earth (i.e. phase voltage)

$$= V_1 + V_2 + V_3 = V_1 + 0.993 V_1 + 1.077 V_1 = 3.07 V_1$$

$$\text{String efficiency} = \frac{3.07 V_1}{3 \times 1.077 V_1} \times 100 = 95\%$$

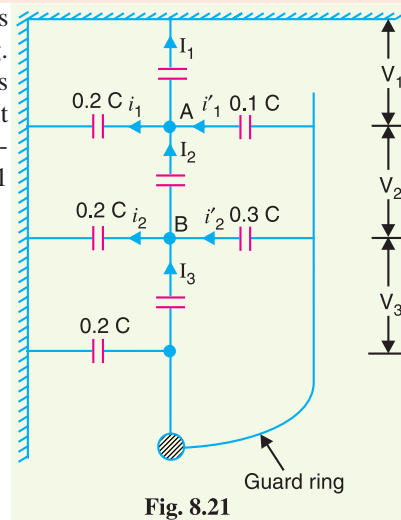

Fig. 8.21

Example 8.12. It is required to grade a string having seven suspension insulators. If the pin to earth capacitance are all equal to C , determine the line to pin capacitance that would give the same voltage across each insulator of the string.

Solution. Let C_1, C_2, \dots, C_6 respectively be the required line to pin capacitances of the units as shown in Fig. 8.22. As the voltage across each insulator has to be the same, therefore,

$$I_1 = I_2 = I_3 = I_4 = I_5 = I_6 = I_7$$

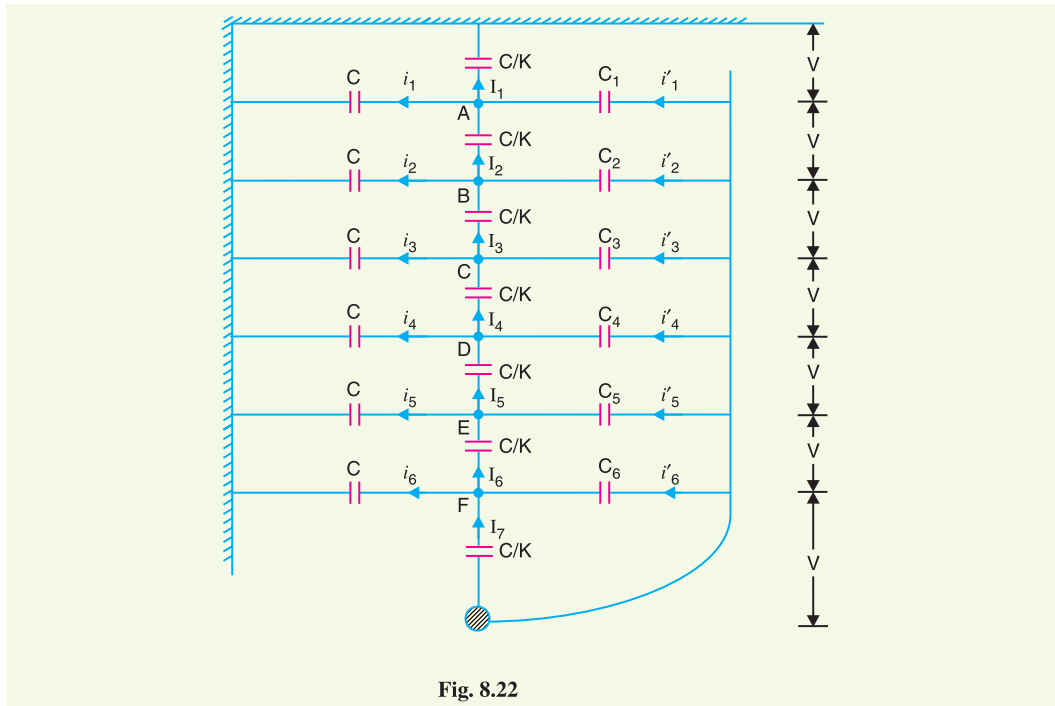

Fig. 8.22

At Junction A

$$i_1' + I_2 = i_1 + I_1$$

or $i_1' = i_1$ ($\because I_1 = I_2$)

or $\omega C_1 (6V) = \omega CV$ (\because Voltage across $C_1 = 6V$)

$\therefore C_1 = C/6 = 0.167C$

At Junction B

$$i_2' = i_2$$

or $\omega C_2 (5V) = \omega C (2V)$

$\therefore C_2 = \frac{2C}{5} = 0.4C$

At Junction C

$$i_3' = i_3$$

or $\omega C_3 (4V) = \omega C (3V)$

$\therefore C_3 = 3C/4 = 0.75C$

At Junction E

$$i_5' = i_5$$

or $\omega C_5 (2V) = \omega C (5V)$

$\therefore C_5 = 5C/2 = 2.5C$

At Junction D

$$i_4' = i_4$$

or $\omega C_4 (3V) = \omega C (4V)$

$\therefore C_4 = 4C/3 = 1.33C$

At Junction F

$$i_6' = i_6$$

or $\omega C_6 V = \omega C (6V)$

$\therefore C_6 = 6C$

TUTORIAL PROBLEMS

1. In a 3-phase overhead system, each line is suspended by a string of 3 insulators. The voltage across the top unit (*i.e.* near the tower) and middle unit are 10 kV and 11 kV respectively. Calculate (i) the ratio of shunt capacitance to self capacitance of each insulator, (ii) the string efficiency and (iii) line voltage.

[(i) 0.1 (ii) 86.76% (iii) 59 kV]

2. Each line of a 3-phase system is suspended by a string of 3 similar insulators. If the voltage across the line unit is 17.5 kV, calculate the line to neutral voltage and string efficiency. Assume that shunt capacitance between each insulator and earthed metal work of tower to be 1/10th of the capacitance of the insulator. [52 kV, 86.67%]
3. The three bus-bar conductors in an outdoor sub-station are supplied by units of post insulators. Each unit consists of a stack of 3-pin insulators fixed one on the top of the other. The voltage across the lowest insulator is 8.45 kV and that across the next is 7.25 kV. Find the bus-bar voltage of the station. [38.8 kV]
4. A string of suspension insulators consists of three units. The capacitance between each link pin and earth is one-sixth of the self-capacitance of each unit. If the maximum voltage per unit is not to exceed 35 kV, determine the maximum voltage that the string can withstand. Also calculate the string efficiency. [84.7 kV; 80.67%]
5. A string of 4 insulators has self-capacitance equal to 4 times the pin-to-earth capacitance. Calculate (i) the voltage distribution across various units as a percentage of total voltage across the string and (ii) string efficiency. [(i) 14.5%, 18.1%, 26.2% and 40.9% (ii) 61.2 %]
6. A string of four suspension insulators is connected across a 285 kV line. The self-capacitance of each unit is equal to 5 times pin to earth capacitance. Calculate :
(i) the potential difference across each unit, (ii) the string efficiency. [(i) 27.65 kV, 33.04 kV, 43.85 kV, 60 kV (ii) 68.5%]
7. Each of three insulators forming a string has self-capacitance of "C" farad. The shunt capacitance of each cap of insulator is 0.25 C to earth and 0.15 C to line. Calculate the voltage distribution across each insulator as a percentage of line voltage to earth and the string efficiency. [31.7%, 29.4%, 38.9%; 85.7%]
8. Each of the three insulators forming a string has a self capacitance of C farad. The shunt capacitance of each insulator is 0.2 C to earth and 0.1 C to line. A guard-ring increases the capacitance of line of the metal work of the lowest insulator to 0.3 C. Calculate the string efficiency of the arrangement :
(i) with the guard ring, (ii) without guard ring. [(i) 95% (ii) 86.13%]
9. A three-phase overhead transmission line is being supported by three-disc suspension insulators; the potentials across the first and second insulator from the top are 8 kV and 11 kV respectively. Calculate (i) the line voltage (ii) the ratio of capacitance between pin and earth to self capacitance of each unit (iii) the string efficiency. [(i) 64.28 V (ii) 0.375 (iii) 68.28%]
10. A 3-phase overhead transmission line is supported on 4-disc suspension insulators. The voltage across the second and third discs are 13.2 kV and 18 kV respectively. Calculate the line voltage and mention the nearest standard voltage. [118.75 kV; 120 kV]

8.10 Corona

When an alternating potential difference is applied across two conductors whose spacing is large as compared to their diameters, there is no apparent change in the condition of atmospheric air surrounding the wires if the applied voltage is low. However, when the applied voltage exceeds a certain value, called *critical disruptive voltage*, the conductors are surrounded by a faint violet glow called corona.

The phenomenon of corona is accompanied by a hissing sound, production of ozone, power loss and radio interference. The higher the voltage is raised, the larger and higher the luminous envelope becomes, and greater are the sound, the power loss and the radio noise. If the applied voltage is increased to breakdown value, a flash-over will occur between the conductors due to the breakdown of air insulation.

The phenomenon of violet glow, hissing noise and production of ozone gas in an overhead transmission line is known as corona.

If the conductors are polished and smooth, the corona glow will be uniform throughout the length of the conductors, otherwise the rough points will appear brighter. With d.c. voltage, there is

difference in the appearance of the two wires. The positive wire has uniform glow about it, while the negative conductor has spotty glow.

Theory of corona formation. Some ionisation is always present in air due to cosmic rays, ultra-violet radiations and radioactivity. Therefore, under normal conditions, the air around the conductors contains some ionised particles (*i.e.*, free electrons and +ve ions) and neutral molecules. When p.d. is applied between the conductors, potential gradient is set up in the air which will have maximum value at the conductor surfaces. Under the influence of potential gradient, the existing free electrons acquire greater velocities. The greater the applied voltage, the greater the potential gradient and more is the velocity of free electrons.

When the potential gradient at the conductor surface reaches about 30 kV per cm (max. value), the velocity acquired by the free electrons is sufficient to strike a neutral molecule with enough force to dislodge one or more electrons from it. This produces another ion and one or more free electrons, which in turn are accelerated until they collide with other neutral molecules, thus producing other ions. Thus, the process of ionisation is cumulative. The result of this ionisation is that either corona is formed or spark takes place between the conductors.

8.11 Factors Affecting Corona

The phenomenon of corona is affected by the physical state of the atmosphere as well as by the conditions of the line. The following are the factors upon which corona depends :

- (i) **Atmosphere.** As corona is formed due to ionisation of air surrounding the conductors, therefore, it is affected by the physical state of atmosphere. In the stormy weather, the number of ions is more than normal and as such corona occurs at much less voltage as compared with fair weather.
- (ii) **Conductor size.** The corona effect depends upon the shape and conditions of the conductors. The rough and irregular surface will give rise to more corona because unevenness of the surface decreases the value of breakdown voltage. Thus a stranded conductor has irregular surface and hence gives rise to more corona than a solid conductor.
- (iii) **Spacing between conductors.** If the spacing between the conductors is made very large as compared to their diameters, there may not be any corona effect. It is because larger distance between conductors reduces the electro-static stresses at the conductor surface, thus avoiding corona formation.
- (iv) **Line voltage.** The line voltage greatly affects corona. If it is low, there is no change in the condition of air surrounding the conductors and hence no corona is formed. However, if the line voltage has such a value that electrostatic stresses developed at the conductor surface make the air around the conductor conducting, then corona is formed.

8.12 Important Terms

The phenomenon of corona plays an important role in the design of an overhead transmission line. Therefore, it is profitable to consider the following terms much used in the analysis of corona effects:

(i) **Critical disruptive voltage.** *It is the minimum phase-neutral voltage at which corona occurs.*

Consider two conductors of radii r cm and spaced d cm apart. If V is the phase-neutral potential, then potential gradient at the conductor surface is given by:

$$g = \frac{V}{r \log_e \frac{d}{r}} \text{ volts / cm}$$

In order that corona is formed, the value of g must be made equal to the breakdown strength of air. The breakdown strength of air at 76 cm pressure and temperature of 25°C is 30 kV/cm (*max*) or

21.2 kV/cm (*r.m.s.*) and is denoted by g_o . If V_c is the phase-neutral potential required under these conditions, then,

$$g_o = \frac{V_c}{r \log_e \frac{d}{r}}$$

where

$$g_o = \text{breakdown strength of air at 76 cm of mercury and } 25^\circ\text{C} \\ = 30 \text{ kV/cm (max) or } 21.2 \text{ kV/cm (r.m.s.)}$$

$$\therefore \text{ Critical disruptive voltage, } V_c = g_o r \log_e \frac{d}{r}$$

The above expression for disruptive voltage is under standard conditions *i.e.*, at 76 cm of Hg and 25°C . However, if these conditions vary, the air density also changes, thus altering the value of g_o . The value of g_o is directly proportional to air density. Thus the breakdown strength of air at a barometric pressure of b cm of mercury and temperature of $t^\circ\text{C}$ becomes δg_o where

$$\delta = \text{air density factor} = \frac{3.92b}{273 + t}$$

Under standard conditions, the value of $\delta = 1$.

$$\therefore \text{ Critical disruptive voltage, } V_c = g_o \delta r \log_e \frac{d}{r}$$

Correction must also be made for the surface condition of the conductor. This is accounted for by multiplying the above expression by irregularity factor m_o .

$$\therefore \text{ Critical disruptive voltage, } V_c = m_o g_o \delta r \log_e \frac{d}{r} \text{ kV/phase}$$

where

$$m_o = 1 \text{ for polished conductors} \\ = 0.98 \text{ to } 0.92 \text{ for dirty conductors} \\ = 0.87 \text{ to } 0.8 \text{ for stranded conductors}$$

(ii) Visual critical voltage. It is the minimum phase-neutral voltage at which corona glow appears all along the line conductors.

It has been seen that in case of parallel conductors, the corona glow does not begin at the disruptive voltage V_c but at a higher voltage V_v called **visual critical voltage**. The phase-neutral effective value of visual critical voltage is given by the following empirical formula :

$$V_v = m_v g_o \delta r \left(1 + \frac{0.3}{\sqrt{\delta r}} \right) \log_e \frac{d}{r} \text{ kV/phase}$$

where m_v is another irregularity factor having a value of 1.0 for polished conductors and 0.72 to 0.82 for rough conductors.

(iii) Power loss due to corona. Formation of corona is always accompanied by energy loss which is dissipated in the form of light, heat, sound and chemical action. When disruptive voltage is exceeded, the power loss due to corona is given by :

$$P = 242.2 \left(\frac{f + 25}{\delta} \right) \sqrt{\frac{r}{d}} (V - V_c)^2 \times 10^{-5} \text{ kW / km / phase}$$

where

$$f = \text{supply frequency in Hz} \\ V = \text{phase-neutral voltage (r.m.s.)} \\ V_c = \text{disruptive voltage (r.m.s.) per phase}$$

8.13 Advantages and Disadvantages of Corona

Corona has many advantages and disadvantages. In the correct design of a high voltage overhead line, a balance should be struck between the advantages and disadvantages.

Advantages

- (i) Due to corona formation, the air surrounding the conductor becomes conducting and hence virtual diameter of the conductor is increased. The increased diameter reduces the electrostatic stresses between the conductors.
- (ii) Corona reduces the effects of transients produced by surges.

Disadvantages

- (i) Corona is accompanied by a loss of energy. This affects the transmission efficiency of the line.
- (ii) Ozone is produced by corona and may cause corrosion of the conductor due to chemical action.
- (iii) The current drawn by the line due to corona is non-sinusoidal and hence non-sinusoidal voltage drop occurs in the line. This may cause inductive interference with neighbouring communication lines.

8.14 Methods of Reducing Corona Effect

It has been seen that intense corona effects are observed at a working voltage of 33 kV or above. Therefore, careful design should be made to avoid corona on the sub-stations or bus-bars rated for 33 kV and higher voltages otherwise highly ionised air may cause flash-over in the insulators or between the phases, causing considerable damage to the equipment. The corona effects can be reduced by the following methods :

- (i) *By increasing conductor size.* By increasing conductor size, the voltage at which corona occurs is raised and hence corona effects are considerably reduced. This is one of the reasons that ACSR conductors which have a larger cross-sectional area are used in transmission lines.
- (ii) *By increasing conductor spacing.* By increasing the spacing between conductors, the voltage at which corona occurs is raised and hence corona effects can be eliminated. However, spacing cannot be increased too much otherwise the cost of supporting structure (*e.g.*, bigger cross arms and supports) may increase to a considerable extent.

Example 8.13. A 3-phase line has conductors 2 cm in diameter spaced equilaterally 1 m apart. If the dielectric strength of air is 30 kV (max) per cm, find the disruptive critical voltage for the line. Take air density factor $\delta = 0.952$ and irregularity factor $m_o = 0.9$.

Solution.

Conductor radius, $r = 2/2 = 1$ cm

Conductor spacing, $d = 1$ m = 100 cm

Dielectric strength of air, $g_o = 30$ kV/cm (max.) = 21.2 kV (r.m.s.) per cm

Disruptive critical voltage, $V_c = m_o g_o \delta r \log_e (d/r)$ kV*/phase (r.m.s. value)
 $= 0.9 \times 21.2 \times 0.952 \times 1 \times \log_e 100/1 = 83.64$ kV/phase

\therefore Line voltage (r.m.s.) = $\sqrt{3} \times 83.64 = 144.8$ kV

Example 8.14. A 132 kV line with 1.956 cm dia. conductors is built so that corona takes place if the line voltage exceeds 210 kV (r.m.s.). If the value of potential gradient at which ionisation occurs can be taken as 30 kV per cm, find the spacing between the conductors.

* As g_o is taken in kV/cm, therefore, V_c will be in kV.

Solution.

Assume the line is 3-phase.

Conductor radius, $r = 1.956/2 = 0.978$ cm

Dielectric strength of air, $g_o = 30/\sqrt{2} = 21.2$ kV (*r.m.s.*) per cm

Disruptive voltage/phase, $V_c = 210/\sqrt{3} = 121.25$ kV

Assume smooth conductors (*i.e.*, irregularity factor $m_o = 1$) and standard pressure and temperature for which air density factor $\delta = 1$. Let d cm be the spacing between the conductors.

\therefore Disruptive voltage (*r.m.s.*) per phase is

$$\begin{aligned} V_c &= m_o g_o \delta r \log_e (d/r) \text{ kV} \\ &= 1 \times 21.2 \times 1 \times 0.978 \times \log_e (d/r) \end{aligned}$$

or $121.25 = 20.733 \log_e (d/r)$

or $\log_e \frac{d}{r} = \frac{121.25}{20.733} = 5.848$

or $2.3 \log_{10} d/r = 5.848$

or $\log_{10} d/r = 5.848/2.3 = 2.5426$

or $d/r = \text{Antilog } 2.5426$

or $d/r = 348.8$

\therefore Conductor spacing, $d = 348.8 \times r = 348.8 \times 0.978 = 341$ cm

Example 8.15. A 3-phase, 220 kV, 50 Hz transmission line consists of 1.5 cm radius conductor spaced 2 metres apart in equilateral triangular formation. If the temperature is 40°C and atmospheric pressure is 76 cm, calculate the corona loss per km of the line. Take $m_o = 0.85$.

Solution.

As seen from Art. 8.12, the corona loss is given by :

$$P = \frac{242 \cdot 2}{\delta} (f + 25) \sqrt{\frac{r}{d}} (V - V_c)^2 \times 10^{-5} \text{ kW/km/phase}$$

Now, $\delta = \frac{3 \cdot 92 b}{273 + t} = \frac{3 \cdot 92 \times 76}{273 + 40} = 0.952$

Assuming $g_o = 21.2$ kV/cm (*r.m.s.*)

\therefore Critical disruptive voltage per phase is

$$\begin{aligned} V_c &= m_o g_o \delta r \log_e d/r \text{ kV} \\ &= 0.85 \times 21.2 \times 0.952 \times 1.5 \times \log_e 200/1.5 = 125.9 \text{ kV} \end{aligned}$$

Supply voltage per phase, $V = 220/\sqrt{3} = 127$ kV

Substituting the above values, we have corona loss as:

$$\begin{aligned} P &= \frac{242 \cdot 2}{0.952} (50 + 25) \times \sqrt{\frac{1.5}{200}} \times (127 - 125.9)^2 \times 10^{-5} \text{ kW/phase/km} \\ &= \frac{242 \cdot 2}{0.952} \times 75 \times 0.0866 \times 1.21 \times 10^{-5} \text{ kW/km/phase} \\ &= 0.01999 \text{ kW/km/phase} \end{aligned}$$

\therefore Total corona loss per km for three phases

$$= 3 \times 0.01999 \text{ kW} = 0.05998 \text{ kW}$$

Example 8.16. A certain 3-phase equilateral transmission line has a total corona loss of 53 kW at 106 kV and a loss of 98 kW at 110.9 kV. What is the disruptive critical voltage? What is the corona loss at 113 kV?

Solution.

The power loss due to corona for 3 phases is given by :

$$P = 3 \times \frac{242 \cdot 2 (f + 25)}{\delta} \sqrt{\frac{r}{d}} (V - V_c)^2 \times 10^{-5} \text{ kW/km}$$

As f , δ , r and d are the same for the two cases,

$$\therefore P \propto (V - V_c)^2$$

For first case, $P = 53 \text{ kW}$ and $V = 106/\sqrt{3} = 61.2 \text{ kV}$

For second case, $P = 98 \text{ kW}$ and $V = 110 \cdot 9/\sqrt{3} = 64 \text{ kV}$

$$\therefore 53 \propto (61.2 - V_c)^2 \quad \dots(i)$$

$$\text{and } 98 \propto (64 - V_c)^2 \quad \dots(ii)$$

Dividing [(ii)/(i)], we get,

$$\frac{98}{53} = \frac{(64 - V_c)^2}{(61.2 - V_c)^2}$$

$$\text{or } V_c = \mathbf{54 \text{ kV}}$$

Let W kilowatt be the power loss at 113 kV.

$$\therefore W \propto \left(\frac{113}{\sqrt{3}} - V_c \right)^2$$

$$\propto (65.2 - 54)^2 \quad \dots(iii)$$

Dividing [(iii)/(i)], we get,

$$\frac{W}{53} = \frac{(65.2 - 54)^2}{(61.2 - 54)^2}$$

$$\therefore W = (11.2/7.2)^2 \times 53 = \mathbf{128 \text{ kW}}$$

TUTORIAL PROBLEMS

1. Estimate the corona loss for a three-phase, 110 kV, 50 Hz, 150 km long transmission line consisting of three conductors each of 10 mm diameter and spaced 2.5 m apart in an equilateral triangle formation. The temperature of air is 30°C and the atmospheric pressure is 750 mm of mercury. Take irregularity factor as 0.85. Ionisation of air may be assumed to take place at a maximum voltage gradient of 30 kV/cm. **[316.8 kW]**
2. Taking the dielectric strength of air to be 30 kV/cm, calculate the disruptive critical voltage for a 3-phase line with conductors of 1 cm radius and spaced symmetrically 4 m apart. **[220 kV line voltage]**
3. A 3-phase, 220 kV, 50 Hz transmission line consists of 1.2 cm radius conductors spaced 2 m at the corners of an equilateral triangle. Calculate the corona loss per km of the line. The condition of the wire is smoothly weathered and the weather is fair with temperature of 20°C and barometric pressure of 72.2 cm of Hg. **[2.148 kW]**

8.15 Sag in Overhead Lines

While erecting an overhead line, it is very important that conductors are under safe tension. If the conductors are too much stretched between supports in a bid to save conductor material, the stress in the conductor may reach unsafe value and in certain cases the conductor may break due to excessive tension. In order to permit safe tension in the conductors, they are not fully stretched but are allowed to have a dip or sag.

*The difference in level between points of supports and the lowest point on the conductor is called **sag**.*

Fig. 8.23. (i) shows a conductor suspended between two equilevel supports A and B . The conductor is not fully stretched but is allowed to have a dip. The lowest point on the conductor is O and the sag is S . The following points may be noted :

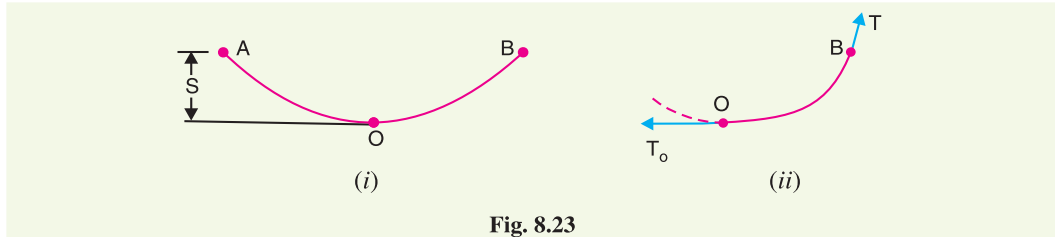

Fig. 8.23

- (i) When the conductor is suspended between two supports at the same level, it takes the shape of catenary. However, if the sag is very small compared with the span, then sag-span curve is like a parabola.
- (ii) The tension at any point on the conductor acts tangentially. Thus tension T_O at the lowest point O acts horizontally as shown in Fig. 8.23. (ii).
- (iii) The horizontal component of tension is constant throughout the length of the wire.
- (iv) The tension at supports is approximately equal to the horizontal tension acting at any point on the wire. Thus if T is the tension at the support B , then $T = T_O$.

Conductor sag and tension. This is an important consideration in the mechanical design of overhead lines. The conductor sag should be kept to a minimum in order to reduce the conductor material required and to avoid extra pole height for sufficient clearance above ground level. It is also desirable that tension in the conductor should be low to avoid the mechanical failure of conductor and to permit the use of less strong supports. However, low conductor tension and minimum sag are not possible. It is because low sag means a tight wire and high tension, whereas a low tension means a loose wire and increased sag. Therefore, in actual practice, a compromise is made between the two.

8.16 Calculation of Sag

In an overhead line, the sag should be so adjusted that tension in the conductors is within safe limits. The tension is governed by conductor weight, effects of wind, ice loading and temperature variations. It is a standard practice to keep conductor tension less than 50% of its ultimate tensile strength *i.e.*, minimum factor of safety in respect of conductor tension should be 2. We shall now calculate sag and tension of a conductor when (i) supports are at equal levels and (ii) supports are at unequal levels.

(i) When supports are at equal levels. Consider a conductor between two equilevel supports A and B with O as the lowest point as shown in Fig. 8.24. It can be proved that lowest point will be at the mid-span.

Let

l = Length of span

w = Weight per unit length of conductor

T = Tension in the conductor.

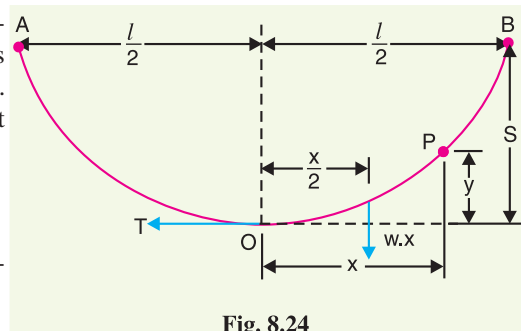

Fig. 8.24

Consider a point P on the conductor. Taking the lowest point O as the origin, let the co-ordinates of point P be x and y . Assuming that the curvature is so small that curved length is equal to its horizontal projection (*i.e.*, $OP = x$), the two forces acting on the portion OP of the conductor are :

- (a) The weight wx of conductor acting at a distance $x/2$ from O .
- (b) The tension T acting at O .

Equating the moments of above two forces about point O , we get,

$$T y = w x \times \frac{x}{2}$$

or
$$y = \frac{w x^2}{2 T}$$

The maximum dip (sag) is represented by the value of y at either of the supports A and B .

At support A , $x = l/2$ and $y = S$

$$\therefore \text{Sag, } S = \frac{w(l/2)^2}{2T} = \frac{w l^2}{8 T}$$

(ii) **When supports are at unequal levels.** In hilly areas, we generally come across conductors suspended between supports at unequal levels. Fig. 8.25 shows a conductor suspended between two supports A and B which are at different levels. The lowest point on the conductor is O .

Let

l = Span length

h = Difference in levels between two supports

x_1 = Distance of support at lower level (*i.e.*, A) from O

x_2 = Distance of support at higher level (*i.e.*, B) from O

T = Tension in the conductor

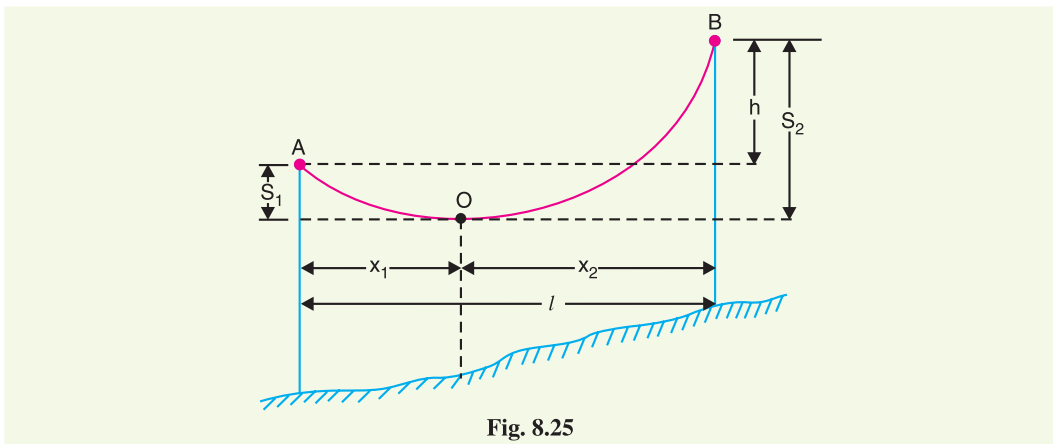

Fig. 8.25

If w is the weight per unit length of the conductor, then,

$$\text{Sag } S_1 = \frac{w x_1^{2*}}{2T}$$

and
$$\text{Sag } S_2 = \frac{w x_2^2}{2T}$$

Also
$$x_1 + x_2 = l \quad \dots(i)$$

$$* y = \frac{w x^2}{2T}$$

At support A , $x = x_1$ and $y = S_1$.

$$\therefore S_1 = \frac{w x_1^2}{2T}$$

$$\begin{aligned} \text{Now} \quad S_2 - S_1 &= \frac{w}{2T} [x_2^2 - x_1^2] = \frac{w}{2T} (x_2 + x_1)(x_2 - x_1) \\ \therefore S_2 - S_1 &= \frac{w l}{2T} (x_2 - x_1) && [\because x_1 + x_2 = l] \\ \text{But} \quad S_2 - S_1 &= h \\ \therefore h &= \frac{w l}{2T} (x_2 - x_1) \\ \text{or} \quad x_2 - x_1 &= \frac{2Th}{wl} && \dots(ii) \end{aligned}$$

Solving exs. (i) and (ii), we get,

$$\begin{aligned} x_1 &= \frac{l}{2} - \frac{Th}{wl} \\ x_2 &= \frac{l}{2} + \frac{Th}{wl} \end{aligned}$$

Having found x_1 and x_2 , values of S_1 and S_2 can be easily calculated.

Effect of wind and ice loading. The above formulae for sag are true only in still air and at normal temperature when the conductor is acted by its weight only. However, in actual practice, a conductor may have ice coating and simultaneously subjected to wind pressure. The weight of ice acts vertically downwards *i.e.*, in the same direction as the weight of conductor. The force due to the wind is assumed to act horizontally *i.e.*, at right angle to the projected surface of the conductor. Hence, the total force on the conductor is the vector sum of horizontal and vertical forces as shown in Fig. 8.26 (iii).

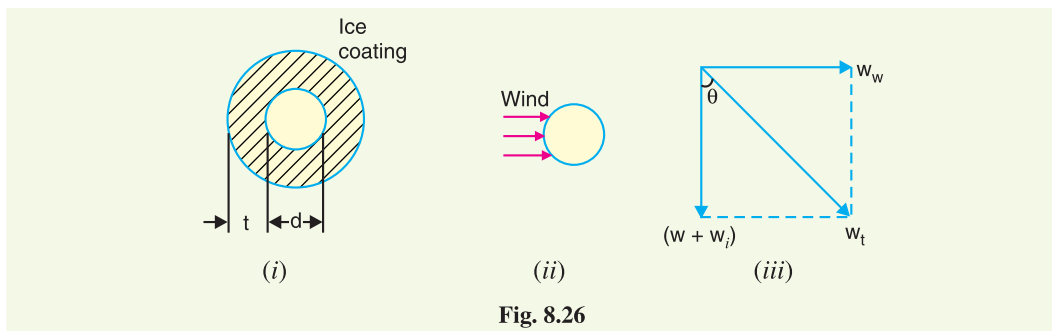

Fig. 8.26

Total weight of conductor per unit length is

$$w_t = \sqrt{(w + w_i)^2 + (w_w)^2}$$

where

$$\begin{aligned} w &= \text{weight of conductor per unit length} \\ &= \text{conductor material density} \times \text{volume per unit length} \\ w_i &= \text{weight of ice per unit length} \\ &= \text{density of ice} \times \text{volume of ice per unit length} \\ &= \text{density of ice} \times \frac{\pi}{4} [(d + 2t)^2 - d^2] \times 1 \\ &= \text{density of ice} \times \pi t (d + t)^* \\ w_w &= \text{wind force per unit length} \\ &= \text{wind pressure per unit area} \times \text{projected area per unit length} \\ &= \text{wind pressure} \times [(d + 2t) \times 1] \end{aligned}$$

* Volume of ice per unit length = $\frac{\pi}{4} [(d + 2t)^2 - d^2] \times 1 = \frac{\pi}{4} [4dt + 4t^2] = \pi t (d + t)$

When the conductor has wind and ice loading also, the following points may be noted :

- (i) The conductor sets itself in a plane at an angle θ to the vertical where

$$\tan \theta = \frac{w_w}{w + w_i}$$

- (ii) The sag in the conductor is given by :

$$S = \frac{w_t l^2}{2T}$$

Hence S represents the slant sag in a direction making an angle θ to the vertical. *If no specific mention is made in the problem, then slant sag is calculated by using the above formula.*

- (iii) The vertical sag = $S \cos \theta$

Example 8.17. A 132 kV transmission line has the following data :

Wt. of conductor = 680 kg/km ; Length of span = 260 m

Ultimate strength = 3100 kg ; Safety factor = 2

Calculate the height above ground at which the conductor should be supported. Ground clearance required is 10 metres.

Solution.

Wt. of conductor/metre run, $w = 680/1000 = 0.68$ kg

Working tension, $T = \frac{\text{Ultimate strength}}{\text{Safety factor}} = \frac{3100}{2} = 1550$ kg

Span length, $l = 260$ m

\therefore Sag = $\frac{w l^2}{8T} = \frac{0.68 \times (260)^2}{8 \times 1550} = 3.7$ m

\therefore Conductor should be supported at a height of $10 + 3.7 = 13.7$ m

Example 8.18. A transmission line has a span of 150 m between level supports. The conductor has a cross-sectional area of 2 cm^2 . The tension in the conductor is 2000 kg. If the specific gravity of the conductor material is 9.9 gm/cm^3 and wind pressure is 1.5 kg/m length, calculate the sag. What is the vertical sag?

Solution.

Span length, $l = 150$ m; Working tension, $T = 2000$ kg

Wind force/m length of conductor, $w_w = 1.5$ kg

Wt. of conductor/m length, $w = \text{Sp. Gravity} \times \text{Volume of 1 m conductor}$
 $= 9.9 \times 2 \times 100 = 1980 \text{ gm} = 1.98$ kg

Total weight of 1 m length of conductor is

$$w_t = \sqrt{w^2 + w_w^2} = \sqrt{(1.98)^2 + (1.5)^2} = 2.48 \text{ kg}$$

\therefore Sag, $S = \frac{w_t l^2}{8T} = \frac{2.48 \times (150)^2}{8 \times 2000} = 3.48$ m

This is the value of slant sag in a direction making an angle θ with the vertical. Referring to Fig. 8.27, the value of θ is given by ;

$$\tan \theta = \frac{w_w}{w} = 1.5/1.98 = 0.76$$

\therefore $\theta = \tan^{-1} 0.76 = 37.23^\circ$

\therefore Vertical sag = $S \cos \theta$
 $= 3.48 \times \cos 37.23^\circ = 2.77$ m

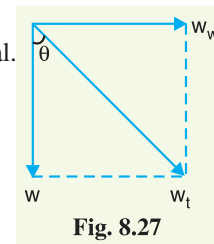

Fig. 8.27

Example 8.19. A transmission line has a span of 200 metres between level supports. The conductor has a cross-sectional area of 1.29 cm^2 , weighs 1170 kg/km and has a breaking stress of 4218 kg/cm^2 . Calculate the sag for a safety factor of 5, allowing a wind pressure of $122 \text{ kg per square metre of projected area}$. What is the vertical sag?

Solution.

Span length, $l = 200 \text{ m}$

Wt. of conductor/m length, $w = 1170/1000 = 1.17 \text{ kg}$

Working tension, $*T = 4218 \times 1.29/5 = 1088 \text{ kg}$

Diameter of conductor, $d = \sqrt{\frac{4 \times \text{area}}{\pi}} = \sqrt{\frac{4 \times 1.29}{\pi}} = 1.28 \text{ cm}$

Wind force/m length, $w_w = \text{Pressure} \times \text{projected area in m}^2$
 $= (122) \times (1.28 \times 10^{-2} \times 1) = 1.56 \text{ kg}$

Total weight of conductor per metre length is

$$w_t = \sqrt{w^2 + w_w^2} = \sqrt{(1.17)^2 + (1.56)^2} = 1.95 \text{ kg}$$

$$\therefore \text{Slant sag, } S = \frac{w_t l^2}{8T} = \frac{1.95 \times (200)^2}{8 \times 1088} = \mathbf{8.96 \text{ m}}$$

The slant sag makes an angle θ with the vertical where value of θ is given by :

$$\theta = \tan^{-1}(w_w/w) = \tan^{-1}(1.56/1.17) = 53.13^\circ$$

$$\therefore \text{Vertical sag} = S \cos \theta = 8.96 \times \cos 53.13^\circ = \mathbf{5.37 \text{ m}}$$

Example 8.20. A transmission line has a span of 275 m between level supports. The conductor has an effective diameter of 1.96 cm and weighs 0.865 kg/m . Its ultimate strength is 8060 kg . If the conductor has ice coating of radial thickness 1.27 cm and is subjected to a wind pressure of 3.9 gm/cm^2 of projected area, calculate sag for a safety factor of 2. Weight of 1 c.c. of ice is 0.91 gm .

Solution.

Span length, $l = 275 \text{ m}$; Wt. of conductor/m length, $w = 0.865 \text{ kg}$

Conductor diameter, $d = 1.96 \text{ cm}$; Ice coating thickness, $t = 1.27 \text{ cm}$

Working tension, $T = 8060/2 = 4030 \text{ kg}$

Volume of ice per metre (i.e., 100 cm) length of conductor

$$= \pi t (d + t) \times 100 \text{ cm}^3$$

$$= \pi \times 1.27 \times (1.96 + 1.27) \times 100 = 1288 \text{ cm}^3$$

Weight of ice per metre length of conductor is

$$w_i = 0.91 \times 1288 = 1172 \text{ gm} = 1.172 \text{ kg}$$

Wind force/m length of conductor is

$$w_w = [\text{Pressure}] \times [(d + 2t) \times 100]$$

$$= [3.9] \times (1.96 + 2 \times 1.27) \times 100 \text{ gm} = 1755 \text{ gm} = 1.755 \text{ kg}$$

Total weight of conductor per metre length of conductor is

$$w_t = \sqrt{(w + w_i)^2 + (w_w)^2}$$

$$= \sqrt{(0.865 + 1.172)^2 + (1.755)^2} = 2.688 \text{ kg}$$

$$* \text{ Working stress} = \frac{\text{Ultimate Strength}}{\text{Safety factor}} = \frac{4218}{5}$$

$$\therefore \text{Working Tension, } T = \text{Working stress} \times \text{conductor area} = 4218 \times 1.29/5$$

$$\therefore \text{Sag} = \frac{w_t l^2}{8T} = \frac{2 \cdot 688 \times (275)^2}{8 \times 4030} = \mathbf{6.3 \text{ m}}$$

Example 8.21. A transmission line has a span of 214 metres between level supports. The conductors have a cross-sectional area of 3.225 cm^2 . Calculate the factor of safety under the following conditions :

Vertical sag = 2.35 m ;

Wind pressure = 1.5 kg/m run

Breaking stress = 2540 kg/cm^2 ;

Wt. of conductor = 1.125 kg/m run

Solution.

Here, $l = 214 \text{ m}$; $w = 1.125 \text{ kg}$; $w_w = 1.5 \text{ kg}$

Total weight of one metre length of conductor is

$$w_t = \sqrt{w^2 + w_w^2} = \sqrt{(1.125)^2 + (1.5)^2} = 1.875 \text{ kg}$$

If f is the factor of safety, then,

$$\text{Working tension, } T = \frac{\text{Breaking stress} \times \text{conductor area}}{\text{safety factor}} = \frac{2540 \times 3.225}{f} = 8191/f \text{ kg}$$

$$\text{Slant Sag, } S = \frac{\text{Vertical sag}}{\cos \theta} = \frac{2.35 \times 1.875}{1.125} = 3.92 \text{ m}$$

$$\text{Now } S = \frac{w_t l^2}{8T}$$

$$\text{or } T = \frac{w_t l^2}{8S}$$

$$\therefore \frac{8191}{f} = \frac{1.875 \times (214)^2}{8 \times 3.92}$$

$$\text{or Safety factor, } f = \frac{8191 \times 8 \times 3.92}{1.875 \times (214)^2} = \mathbf{3}$$

Example 8.22. An overhead line has a span of 150 m between level supports. The conductor has a cross-sectional area of 2 cm^2 . The ultimate strength is 5000 kg/cm^2 and safety factor is 5. The specific gravity of the material is 8.9 gm/cc . The wind pressure is 1.5 kg/m . Calculate the height of the conductor above the ground level at which it should be supported if a minimum clearance of 7 m is to be left between the ground and the conductor.

Solution.

Span length, $l = 150 \text{ m}$;

Wind force/m run, $w_w = 1.5 \text{ kg}$

Wt. of conductor/m run, $w = \text{conductor area} \times 100 \text{ cm} \times \text{sp. gravity}$

$$= 2 \times 100 \times 8.9 = 1780 \text{ gm} = 1.78 \text{ kg}$$

Working tension,

$$T = 5000 \times 2/5 = 2000 \text{ kg}$$

Total weight of one metre length of conductor is

$$w_t = \sqrt{w^2 + w_w^2} = \sqrt{(1.78)^2 + (1.5)^2} = 2.33 \text{ kg}$$

$$\text{Slant sag, } S = \frac{w_t l^2}{8T} = \frac{2.33 \times (150)^2}{8 \times 2000} = 3.28 \text{ m}$$

$$\text{Vertical sag} = S \cos \theta = 3.28 \times w/w_t = 3.28 \times 1.78/2.33 = 2.5 \text{ m}$$

Conductor should be supported at a height of $7 + 2.5 = \mathbf{9.5 \text{ m}}$

* The slant sag makes an angle θ with the vertical.

$$\therefore \cos \theta = w/w_t = 1.125/1.875$$

Example 8.23. The towers of height 30 m and 90 m respectively support a transmission line conductor at water crossing. The horizontal distance between the towers is 500 m. If the tension in the conductor is 1600 kg, find the minimum clearance of the conductor and water and clearance mid-way between the supports. Weight of conductor is 1.5 kg/m. Bases of the towers can be considered to be at water level.

Solution. Fig. 8.28 shows the conductor suspended between two supports A and B at different levels with O as the lowest point on the conductor.

Here, $l = 500$ m ; $w = 1.5$ kg ; $T = 1600$ kg.

Difference in levels between supports, $h = 90 - 30 = 60$ m. Let the lowest point O of the conductor be at a distance x_1 from the support at lower level (i.e., support A) and at a distance x_2 from the support at higher level (i.e., support B).

Obviously, $x_1 + x_2 = 500$ m ...(i)

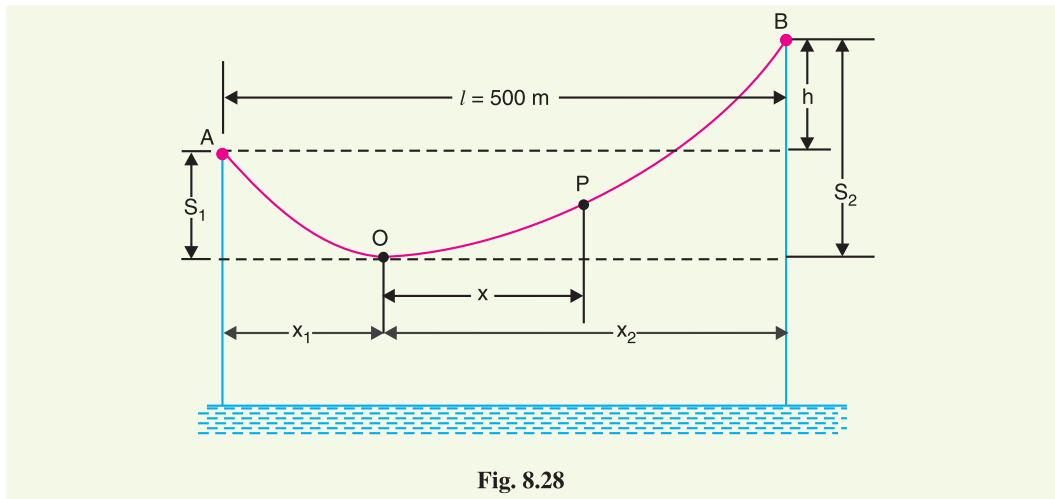

Fig. 8.28

$$\text{Now} \quad \text{Sag } S_1 = \frac{w x_1^2}{2T} \quad \text{and} \quad \text{Sag } S_2 = \frac{w x_2^2}{2T}$$

$$\therefore \quad h = S_2 - S_1 = \frac{w x_2^2}{2T} - \frac{w x_1^2}{2T}$$

$$\text{or} \quad 60 = \frac{w}{2T} (x_2 + x_1)(x_2 - x_1)$$

$$\therefore \quad x_2 - x_1 = \frac{60 \times 2 \times 1600}{1.5 \times 500} = 256 \text{ m} \quad \text{...(ii)}$$

Solving exps. (i) and (ii), we get, $x_1 = 122$ m; $x_2 = 378$ m

$$\text{Now,} \quad S_1 = \frac{w x_1^2}{2T} = \frac{1.5 \times (122)^2}{2 \times 1600} = 7 \text{ m}$$

$$\begin{aligned} \text{Clearance of the lowest point } O \text{ from water level} \\ = 30 - 7 = \mathbf{23 \text{ m}} \end{aligned}$$

Let the mid-point P be at a distance x from the lowest point O.

$$\text{Clearly,} \quad x = 250 - x_1 = 250 - 122 = 128 \text{ m}$$

$$\text{Sag at mid-point } P, \quad S_{mid} = \frac{w x^2}{2T} = \frac{1.5 \times (128)^2}{2 \times 1600} = 7.68 \text{ m}$$

Clearance of mid-point P from water level

$$= 23 + 7.68 = \mathbf{30.68 \text{ m}}$$

Example 8.24. An overhead transmission line conductor having a parabolic configuration weighs 1.925 kg per metre of length. The area of X-section of the conductor is 2.2 cm² and the ultimate strength is 8000 kg/cm². The supports are 600 m apart having 15 m difference of levels. Calculate the sag from the taller of the two supports which must be allowed so that the factor of safety shall be 5. Assume that ice load is 1 kg per metre run and there is no wind pressure.

Solution. Fig. 8.29. shows the conductor suspended between two supports at A and B at different levels with O as the lowest point on the conductor.

Here, $l = 600 \text{ m}$; $w_i = 1 \text{ kg}$; $h = 15 \text{ m}$
 $w = 1.925 \text{ kg}$; $T = 8000 \times 2.2/5 = 3520 \text{ kg}$

Total weight of 1 m length of conductor is

$$w_t = w + w_i = 1.925 + 1 = 2.925 \text{ kg}$$

Let the lowest point O of the conductor be at a distance x_1 from the support at lower level (i.e., A) and at a distance x_2 from the support at higher level (i.e., B).

Clearly, $x_1 + x_2 = 600 \text{ m}$... (i)

Now, $h = S_2 - S_1 = \frac{w_t x_2^2}{2T} - \frac{w_t x_1^2}{2T}$

or $15 = \frac{w_t}{2T} (x_2 + x_1)(x_2 - x_1)$

$\therefore x_2 - x_1 = \frac{2 \times 15 \times 3520}{2.925 \times 600} = 60 \text{ m}$... (ii)

Solving eqns. (i) and (ii), we have, $x_1 = 270 \text{ m}$ and $x_2 = 330 \text{ m}$

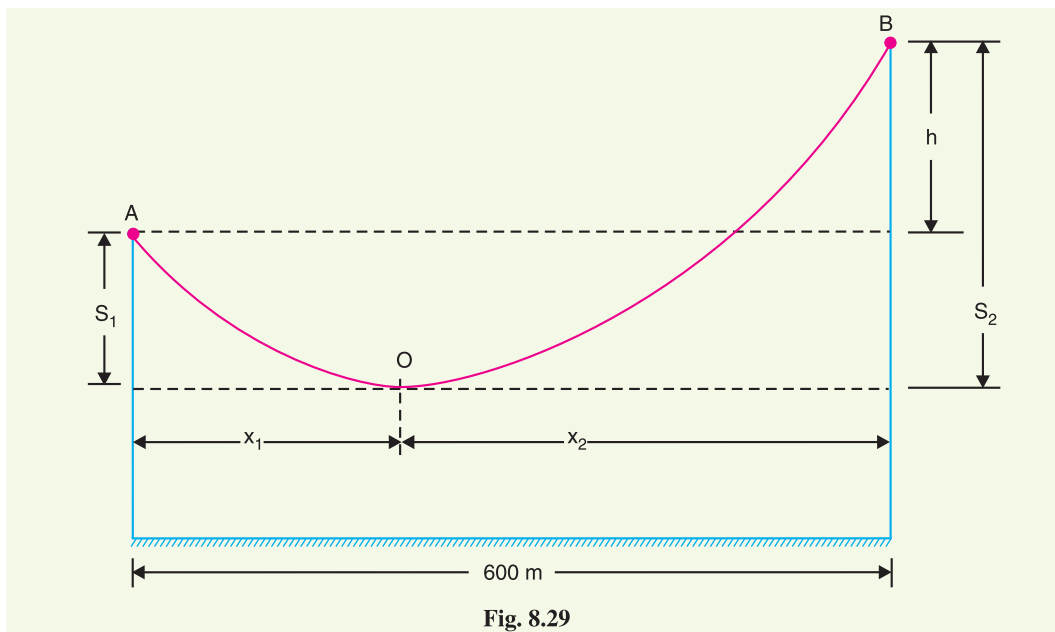

Fig. 8.29

Sag from the taller of the two towers is

$$S_2 = \frac{w_t x_2^2}{2T} = \frac{2.925 \times (330)^2}{2 \times 3520} = \mathbf{45.24 \text{ m}}$$

Example 8.25. An overhead transmission line at a river crossing is supported from two towers at heights of 40 m and 90 m above water level, the horizontal distance between the towers being 400 m. If the maximum allowable tension is 2000 kg, find the clearance between the conductor and water at a point mid-way between the towers. Weight of conductor is 1 kg/m.

Solution. Fig. 8.30 shows the whole arrangement.

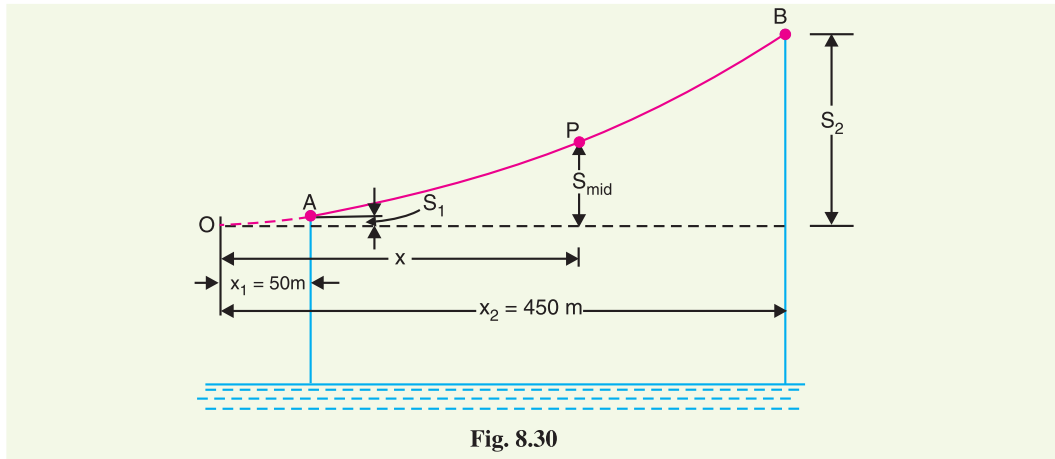

Fig. 8.30

$$\text{Here,} \quad h = 90 - 40 = 50 \text{ m}; \quad l = 400 \text{ m}$$

$$T = 2000 \text{ kg}; \quad w = 1 \text{ kg/m}$$

$$\text{Obviously,} \quad x_1 + x_2 = 400 \text{ m} \quad \dots(i)$$

$$\text{Now} \quad h = S_2 - S_1 = \frac{wx_2^2}{2T} - \frac{wx_1^2}{2T}$$

$$\text{or} \quad 50 = \frac{w}{2T} (x_2 + x_1)(x_2 - x_1)$$

$$\therefore \quad x_2 - x_1 = \frac{50 \times 2 \times 2000}{400} = 500 \text{ m} \quad \dots(ii)$$

Solving exps. (i) and (ii), we get, $x_2 = 450 \text{ m}$ and $x_1 = -50 \text{ m}$

Now x_2 is the distance of higher support B from the lowest point O on the conductor, whereas x_1 is that of lower support A. As the span is 400 m, therefore, point A lies on the same side of O as B (see Fig. 8.30).

Horizontal distance of mid-point P from lowest point O is

$$x = \text{Distance of A from O} + 400/2 = 50 + 200 = 250 \text{ m}$$

$$\therefore \text{ Sag at point P,} \quad S_{mid} = \frac{wx^2}{2T} = \frac{1 \times (250)^2}{2 \times 2000} = 15.6 \text{ m}$$

$$\text{Now} \quad \text{Sag } S_2 = \frac{wx_2^2}{2T} = \frac{1 \times (450)^2}{2 \times 2000} = 50.6 \text{ m}$$

Height of point B above mid-point P

$$= S_2 - S_{mid} = 50.6 - 15.6 = 35 \text{ m}$$

\therefore Clearance of mid-point P above water level

$$= 90 - 35 = \mathbf{55 \text{ m}}$$

Example 8.26. A transmission line over a hillside where the gradient is 1 : 20, is supported by two 22 m high towers with a distance of 300 m between them. The lowest conductor is fixed 2 m below the top of each tower. Find the clearance of the conductor from the ground. Given that conductor weighs 1 kg/m and the allowable tension is 1500 kg.

$$\therefore \frac{w}{T} = \frac{8S}{l^2} = \frac{8 \times 10}{(300)^2} = \frac{8}{9 \times 10^3}$$

$$\text{Height of tower} = \text{Sag} + \text{Clearance} = 10 + 8 = 18 \text{ m}$$

On sloping ground. The conductors are supported between towers AD and BE over a sloping ground having a gradient 1 in 15 as shown in Fig. 8.32. The height of each tower (AD or BE) is 18 m.

Vertical distance between the two towers is

$$h = EC = DE \sin \theta = 300 \times 1/15 = 20 \text{ m}$$

$$\text{Now } x_1 + x_2 = 300 \text{ m} \quad \dots(i)$$

$$\text{Also } h = \frac{w x_2^2}{2T} - \frac{w x_1^2}{2T} = \frac{w}{2T} (x_2 + x_1)(x_2 - x_1)$$

$$\therefore x_2 - x_1 = \frac{2Th}{w(x_2 + x_1)} = \frac{2 \times 9 \times 10^3 \times 20}{8 \times 300} = 150 \text{ m} \quad \dots(ii)$$

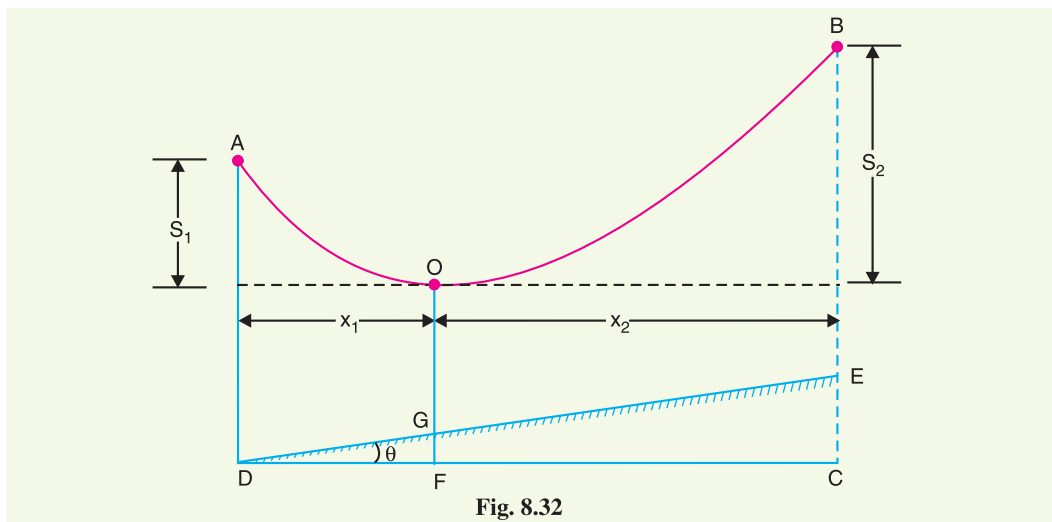

Fig. 8.32

Solving exps. (i) and (ii), we have, $x_1 = 75 \text{ m}$ and $x_2 = 225 \text{ m}$

$$\text{Now } S_1 = \frac{w x_1^2}{2T} = \frac{8 \times (75)^2}{2 \times 9 \times 10^3} = 2.5 \text{ m}$$

$$S_2 = \frac{w x_2^2}{2T} = \frac{8 \times (225)^2}{2 \times 9 \times 10^3} = 22.5 \text{ m}$$

Clearance of point O from the ground is

$$OG = BC - S_2 - GF = 38 - 22.5 - 5 = 10.5 \text{ m}$$

$$[\because GF = x_1 \tan \theta = 75 \times 1/15 = 5\text{m}]$$

Since O is the origin, the equation of slope of ground is given by :

$$y = mx + A$$

$$\text{Here } m = 1/15 \text{ and } A = OG = -10.5 \text{ m}$$

$$\therefore y = \frac{x}{15} - 10.5$$

\therefore Clearance C from the ground at any point x is

* $DE \approx DC = 300 \text{ m}$

$$C = \text{Equation of conductor curve} - y = \left(\frac{w x^2}{2T} \right) - \left(\frac{x}{15} - 10 \cdot 5 \right)$$

$$= \frac{8x^2}{2 \times 9 \times 10^3} - \left(\frac{x}{15} - 10 \cdot 5 \right)$$

$$\therefore C = \frac{x^2}{2250} - \frac{x}{15} + 10 \cdot 5$$

Clearance will be minimum when $dC/dx = 0$ i.e.,

$$\frac{d}{dx} \left[\frac{x^2}{2250} - \frac{x}{15} + 10 \cdot 5 \right] = 0$$

$$\text{or} \quad \frac{2x}{2250} - \frac{1}{15} = 0$$

$$\text{or} \quad x = \frac{1}{15} \times \frac{2250}{2} = 75 \text{ m}$$

i.e., minimum clearance will be at a point 75 m from O .

$$\begin{aligned} \text{Minimum clearance} &= \frac{x^2}{2250} - \frac{x}{15} + 10 \cdot 5 = (75)^2/2250 - 75/15 + 10 \cdot 5 \\ &= 2 \cdot 5 - 5 + 10 \cdot 5 = 8 \text{ m} \end{aligned}$$

TUTORIAL PROBLEMS

1. A transmission line conductor is supported from two towers at heights of 70 m above water level. The horizontal distance between the towers is 300 m. If the tension in the conductors is 1500 kg, find the clearance at a point mid-way between the towers. The size of the conductor is $0 \cdot 9 \text{ cm}^2$ and density of conductor material is $8 \cdot 9 \text{ gm/cm}^3$. **[64 m]**
2. An overhead line has a span of 260 m, the weight of the line conductor is 0.68 kg per metre run. Calculate the maximum sag in the line. The maximum allowable tension in the line is 1550 kg. **[3.7 m]**
3. A transmission line has a span of 150 m between level supports. The cross-sectional area of the conductor is $1 \cdot 25 \text{ cm}^2$ and weighs 100 kg per 100 m. The breaking stress is 4220 kg/cm^2 . Calculate the factor of safety if the sag of the line is 3.5 m. Assume a maximum wind pressure of 100 kg per sq. metre. **[4]**
4. A transmission line has a span of 150 m between the level supports. The conductor has a cross-sectional area of 2 cm^2 . The ultimate strength is 5000 kg/cm^2 . The specific gravity of the material is $8 \cdot 9 \text{ gm/cm}^3$. If the wind pressure is 1.5 kg/m length of conductor, calculate the sag at the centre of the conductor if factor of safety is 5. **[3.28 m]**
5. A transmission line has a span of 250 m between supports, the supports being at the same level. The conductor has a cross-sectional area of $1 \cdot 29 \text{ cm}^2$. The ultimate strength is 4220 kg/cm^2 and factor of safety is 2. The wind pressure is 40 kg/cm^2 . Calculate the height of the conductor above ground level at which it should be supported if a minimum clearance of 7m is to be kept between the ground and the conductor. **[10.24 m]**
6. A transmission line has a span of 150 m between level supports. The conductor has a cross-sectional area of 2 cm^2 . The ultimate strength is 5000 kg/cm^2 . The specific gravity of the material is $8 \cdot 9 \text{ gm/cm}^3$. If the wind pressure is 1.5 kg/m length of the conductor, calculate the sag if factor of safety is 5. **[3.5 m]**
7. Two towers of height 40 m and 30 m respectively support a transmission line conductor at water crossing. The horizontal distance between the towers is 300 m. If the tension in the conductor is 1590 kg, find the clearance of the conductor at a point mid-way between the supports. Weight of conductor is 0.8 kg/m. Bases of the towers can be considered to be at the water level. **[59 m]**
8. An overhead transmission line at a river crossing is supported from two towers at heights of 50 m and 100 m above the water level. The horizontal distance between the towers is 400 m. If the maximum allowable tension is 1800 kg and the conductor weighs 1 kg/m, find the clearance between the conductor and water at a point mid-way between the supports. **[63.8 m]**

8.17 Some Mechanical Principles

Mechanical factors of safety to be used in transmission line design should depend to some extent on the importance of continuity of operation in the line under consideration. In general, the strength of the line should be such as to provide against the worst *probable* weather conditions. We now discuss some important points in the mechanical design of overhead transmission lines.

(i) Tower height : Tower height depends upon the length of span. With long spans, relatively few towers are required but they must be tall and correspondingly costly. It is not usually possible to determine the tower height and span length on the basis of direct construction costs because the lightning hazards increase greatly as the height of the conductors above ground is increased. This is one reason that horizontal spacing is favoured in spite of the wider right of way required.

(ii) Conductor clearance to ground : The conductor clearance to ground at the time of greatest sag should not be less than some specified distance (usually between 6 and 12 m), depending on the voltage, on the nature of the country and on the local laws. The greatest sag may occur on the hottest day of summer on account of the expansion of the wire or it may occur in winter owing to the formation of a heavy coating of ice on the wires. Special provisions must be made for melting ice from the power lines.

(iii) Sag and tension : When laying overhead transmission lines, it is necessary to allow a reasonable factor of safety in respect of the tension to which the conductor is subjected. The tension is governed by the effects of wind, ice loading and temperature variations. The relationship between tension and sag is dependent on the loading conditions and temperature variations. For example, the tension increases when the temperature decreases and there is a corresponding decrease in the sag. Icing-up of the line and wind loading will cause stretching of the conductor by an amount dependent on the line tension.

In planning the sag, tension and clearance to ground of a given span, a maximum stress is selected. It is then aimed to have this stress developed at the worst probable weather conditions (*i.e.* minimum expected temperature, maximum ice loading and maximum wind). Wind loading increases the sag in the direction of resultant loading but decreases the vertical component. Therefore, in clearance calculations, the effect of wind should not be included unless horizontal clearance is important.

(iv) Stringing charts : For use in the field work of stringing the conductors, temperature-sag and temperature-tension charts are plotted for the given conductor and loading conditions. Such curves are called stringing charts (see Fig. 8.33). These charts are very helpful while stringing overhead lines.

(v) Conductor spacing : Spacing of conductors should be such as to provide safety against flash-over when the wires are swinging in the wind. The proper spacing is a function of span length, voltage and weather conditions. The use of horizontal spacing eliminates the danger caused by unequal ice loading. Small wires or wires of light material are subjected to more swinging by the wind than heavy conductors. Therefore, light wires should be given greater spacings.

(vi) Conductor vibration : Wind exerts pressure on the exposed surface of the conductor. If the wind velocity is small, the swinging of conductors is harmless provided the clearance is sufficiently large so that conductors do not approach within the sparking distance of each other. A completely different type of vibration, called *dancing*, is caused by the action of fairly strong wind on a

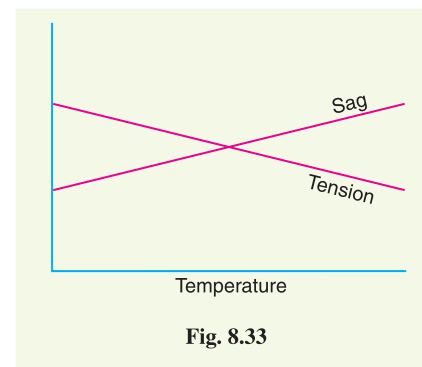

wire covered with ice, when the ice coating happens to take a form which makes a good air-foil section. Then the whole span may sail up like a kite until it reaches the limit of its slack, stops with a jerk and falls or sails back. The harmful effects of these vibrations occur at the clamps or supports where the conductor suffers fatigue and breaks eventually. In order to protect the conductors, dampers are used.

SELF-TEST

1. Fill in the blanks by inserting appropriate words/figures.

- (i) Cross-arms are used on poles or towers to provide to the insulators.
- (ii) The most commonly used material for insulators of overhead lines is
- (iii) The potential across the various discs of suspension string is different because of capacitance.
- (iv) In a string of suspension insulators, the maximum voltage appears across the unit to the conductor.
- (v) If the string efficiency is 100%, it means that
- (vi) If shunt capacitance is reduced, then string efficiency is
- (vii) If the spacing between the conductors is increased, then corona effect is
- (viii) If sag in an overhead line increases, tension in the line
- (ix) By using a guard ring, string efficiency is
- (x) Shunt capacitance in suspension insulators can be decreased by increasing the distance of from

2. Pick up the correct words/figures from the brackets and fill in the blanks.

- (i) The insulator is so designed that it should fail only by (*flash-over, puncture*)
- (ii) Suspension type insulators are used for voltages beyond (*33 kV, 400 V, 11 kV*)
- (iii) In a string of suspension insulators, if the unit nearest to the conductor breaks down, then other units will (*also breakdown, remain intact*)
- (iv) A shorter string has string efficiency than a larger one. (*less, more*)
- (v) Corona effect is pronounced in stormy weather as compared to fair weather. (*more, less*)
- (vi) If the conductor size is increased, the corona effect is (*increased, decreased*)
- (vii) The longer the cross arm, the the string efficiency. (*greater, lesser*)
- (viii) The discs of the strain insulators are used in plane. (*vertical, horizontal*)
- (ix) Sag is provided in overhead lines so that
(*Safe tension is not exceeded, repair can be done*)
- (x) When an insulator breaks down by puncture, it is damaged.
(*permanently, only partially*)

ANSWERS

1. (i) support (ii) porcelain (iii) shunt (iv) nearest (v) potential across each disc is the same (vi) increased (vii) reduced (viii) decreases (ix) increased (x) conductor, tower.
2. (i) flash-over (ii) 33 kV (iii) also breakdown (iv) more (v) more (vi) decreased (vii) greater (viii) vertical (ix) safe tension is not exceeded (x) permanently.

CHAPTER REVIEW TOPICS

1. Name the important components of an overhead transmission line.
2. Discuss the various conductor materials used for overhead lines. What are their relative advantages and disadvantages ?
3. Discuss the various types of line supports.
4. Why are insulators used with overhead lines ? Discuss the desirable properties of insulators.

5. Discuss the advantages and disadvantages of (i) pin-type insulators (ii) suspension type insulators.
6. Explain how the electrical breakdown can occur in an insulator.
7. What is a strain insulator and where is it used ? Give a sketch to show its location.
8. Give reasons for unequal potential distribution over a string of suspension insulators.
9. Define and explain string efficiency. Can its value be equal to 100% ?
10. Show that in a string of suspension insulators, the disc nearest to the conductor has the highest voltage across it.
11. Explain various methods of improving string efficiency.
12. What is corona? What are the factors which affect corona ?
13. Discuss the advantages and disadvantages of corona.
14. Explain the following terms with reference to corona :
 - (i) Critical disruptive voltage
 - (ii) Visual critical voltage
 - (iii) Power loss due to corona
15. Describe the various methods for reducing corona effect in an overhead transmission line.
16. What is a sag in overhead lines ? Discuss the disadvantages of providing too small or too large sag on a line.
17. Deduce an approximate expression for sag in overhead lines when
 - (i) supports are at equal levels
 - (ii) supports are at unequal levels.

DISCUSSION QUESTIONS

1. What is the need for stranding the conductors ?
2. Is sag a necessity or an evil ? Discuss.
3. String efficiency for a d.c. system is 100% ? Discuss.
4. Can string efficiency in an a.c. system be 100% ?
5. Why are suspension insulators preferred for high voltage power transmission ?
6. Give reasons for the following :
 - (i) A.C.S.R. conductors are preferred for transmission and distribution lines.
 - (ii) Conductors are not fully stretched between supports.