

## CHAPTER

# 9



# Electrical Design of Overhead Lines

- 9.1 Constants of a Transmission Line
- 9.2 Resistance of a Transmission Line
- 9.3 Skin Effect
- 9.4 Flux Linkages
- 9.5 Inductance of a Single Phase Two-Wire Line
- 9.6 Inductance of a 3-Phase Overhead Line
- 9.7 Concept of Self-GMD and Mutual - GMD
- 9.8 Inductance Formulas in Terms of GMD
- 9.9 Electric Potential
- 9.10 Capacitance of a Single Phase Two-Wire Line
- 9.11 Capacitance of a 3-Phase Overhead Line

## Introduction

It has already been discussed that transmission of electric power is done by 3-phase, 3-wire overhead lines. An a.c. transmission line has resistance, inductance and capacitance uniformly distributed along its length. These are known as constants or parameters of the line. The performance of a transmission line depends to a considerable extent upon these constants. For instance, these constants determine whether the efficiency and voltage regulation of the line will be good or poor. Therefore, a sound concept of these constants is necessary in order to make the electrical design of a transmission line a technical success. In this chapter, we shall focus our attention on the methods of calculating these constants for a given transmission line. Out of these three parameters of a transmission line, we shall pay greatest attention to inductance and capacitance. Resistance is certainly of equal importance but requires less explanation since it is not a function of conductor arrangement.

### 9.1 Constants of a Transmission Line

A transmission line has resistance, inductance and capacitance uniformly distributed along the whole length of the line. Before we pass on to the methods of finding these constants for a transmission line, it is profitable to understand them thoroughly.

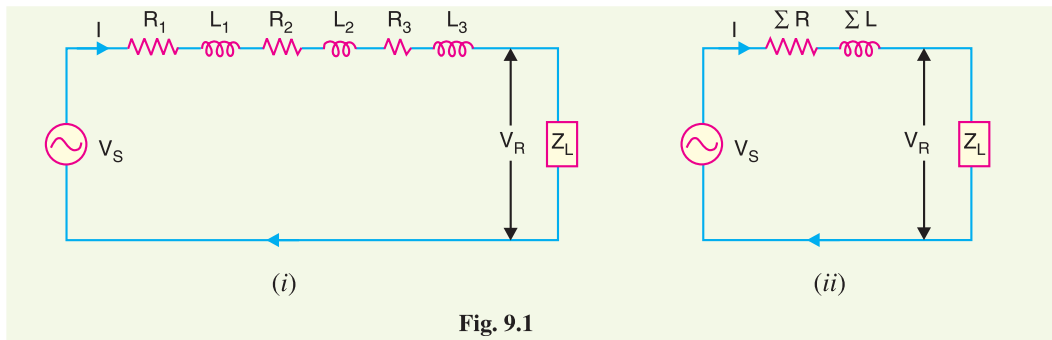

Fig. 9.1

- (i) **Resistance.** It is the opposition of line conductors to current flow. The resistance is distributed uniformly along the whole length of the line as shown in Fig. 9.1 (i). However, the performance of a transmission line can be analysed conveniently if distributed resistance is considered as lumped as shown in Fig. 9.1(ii).
- (ii) **Inductance.** When an alternating current flows through a conductor, a changing flux is set up which links the conductor. Due to these flux linkages, the conductor possesses inductance. Mathematically, inductance is defined as the flux linkages per ampere *i.e.*,

$$\text{Inductance, } L = \frac{\Psi}{I} \text{ henry}$$

where  $\Psi$  = flux linkages in weber-turns  
 $I$  = current in amperes

The inductance is also uniformly distributed along the length of the \* line as shown in Fig. 9.1(i). Again for the convenience of analysis, it can be taken to be lumped as shown in Fig. 9.1(ii).

- (iii) **Capacitance.** We know that any two conductors separated by an insulating material constitute a capacitor. As any two conductors of an overhead transmission line are separated by air which acts as an insulation, therefore, capacitance exists between any two overhead line conductors. The capacitance between the conductors is the charge per unit potential difference *i.e.*,

$$\text{Capacitance, } C = \frac{q}{v} \text{ farad}$$

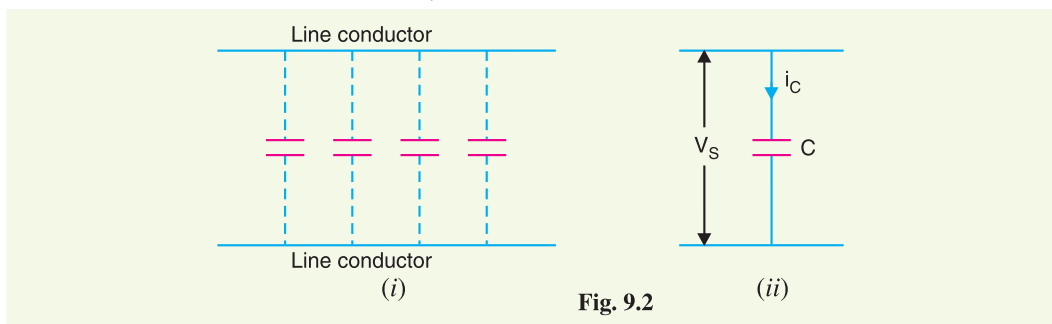

Fig. 9.2

\* The two parallel conductors of a transmission line form a rectangular loop of one turn. The changing flux in the line links the loop and hence the line has inductance.

where  $q$  = charge on the line in coulomb  
 $v$  = p.d. between the conductors in volts

The capacitance is uniformly distributed along the whole length of the line and may be regarded as a uniform series of capacitors connected between the conductors as shown in Fig. 9.2(i). When an alternating voltage is impressed on a transmission line, the charge on the conductors at any point increases and decreases with the increase and decrease of the instantaneous value of the voltage between conductors at that point. The result is that a current (known as *charging current*) flows between the conductors [See Fig. 9.2(ii)]. This charging current flows in the line even when it is open-circuited *i.e.*, supplying no load. It affects the voltage drop along the line as well as the efficiency and power factor of the line.

## 9.2 Resistance of a Transmission Line

The resistance of transmission line conductors is the most important cause of power loss in a transmission line. The resistance  $R$  of a line conductor having resistivity  $\rho$ , length  $l$  and area of cross-section  $a$  is given by ;

$$R = \rho \frac{l}{a}$$

The variation of resistance of metallic conductors with temperature is practically linear over the normal range of operation. Suppose  $R_1$  and  $R_2$  are the resistances of a conductor at  $t_1^\circ\text{C}$  and  $t_2^\circ\text{C}$  ( $t_2 > t_1$ ) respectively. If  $\alpha_1$  is the temperature coefficient at  $t_1^\circ\text{C}$ , then,

$$R_2 = R_1 [1 + \alpha_1 (t_2 - t_1)]$$

where  $\alpha_1 = \frac{\alpha_0}{1 + \alpha_0 t_1}$

$$\alpha_0 = \text{temperature coefficient at } 0^\circ\text{C}$$

- (i) In a single phase or 2-wire d.c line, the total resistance (known as *loop resistance*) is equal to double the resistance of either conductor.
- (ii) In case of a 3-phase transmission line, resistance per phase is the resistance of one conductor.

## 9.3 Skin Effect

When a conductor is carrying steady direct current (d.c.), this current is uniformly distributed over the whole X-section of the conductor. However, an alternating current flowing through the conductor does not distribute uniformly, rather it has the tendency to concentrate near the surface of the conductor as shown in Fig. 9.3. This is known as skin effect.

*The tendency of alternating current to concentrate near the surface of a conductor is known as skin effect.*

Due to skin effect, the effective area of cross-section of the conductor through which current flows is reduced. Consequently, the resistance of the conductor is slightly increased when carrying an alternating current. The cause of skin effect can be easily explained. A solid conductor may be thought to be consisting of a large number of strands, each carrying a small part of the current. The \*inductance of each strand will vary according to its position. Thus, the strands near the centre are surrounded by a greater magnetic flux and hence have larger inductance than that near the surface. The high reactance of inner strands

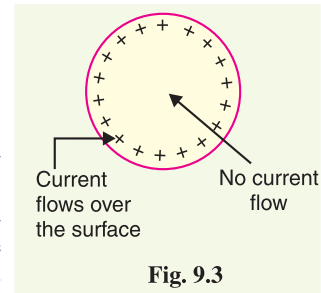

\* For a direct current, inductance is zero and hence the current distributes uniformly over the entire X-section of the conductor.

causes the alternating current to flow near the surface of conductor. This crowding of current near the conductor surface is the skin effect. The skin effect depends upon the following factors :

- (i) Nature of material
- (ii) Diameter of wire – increases with the diameter of wire.
- (iii) Frequency – increases with the increase in frequency.
- (iv) Shape of wire – less for stranded conductor than the solid conductor.

It may be noted that skin effect is negligible when the supply frequency is low (< 50 Hz) and conductor diameter is small (< 1cm).

## 9.4 Flux Linkages

As stated earlier, the inductance of a circuit is defined as the flux linkages per unit current. Therefore, in order to find the inductance of a circuit, the determination of flux linkages is of primary importance. We shall discuss two important cases of flux linkages.

**1. Flux linkages due to a single current carrying conductor.** Consider a long straight cylindrical conductor of radius  $r$  metres and carrying a current  $I$  amperes (r.m.s.) as shown in Fig. 9.4 (i). This current will set up magnetic field. The magnetic lines of force will exist inside the conductor as well as outside the conductor. Both these fluxes will contribute to the inductance of the conductor.

(i) **Flux linkages due to internal flux.** Refer to Fig. 9.4 (ii) where the X-section of the conductor is shown magnified for clarity. The magnetic field intensity at a point  $x$  metres from the centre is given by;

$$*H_x = \frac{I_x}{2\pi x}$$

Assuming a uniform current density,

$$I_x = \frac{\pi x^2}{\pi r^2} I = \frac{x^2}{r^2} I$$

$$\therefore H_x = \frac{x^2}{r^2} \times I \times \frac{1}{2\pi x} = \frac{x}{2\pi r^2} I \text{ AT/m}$$

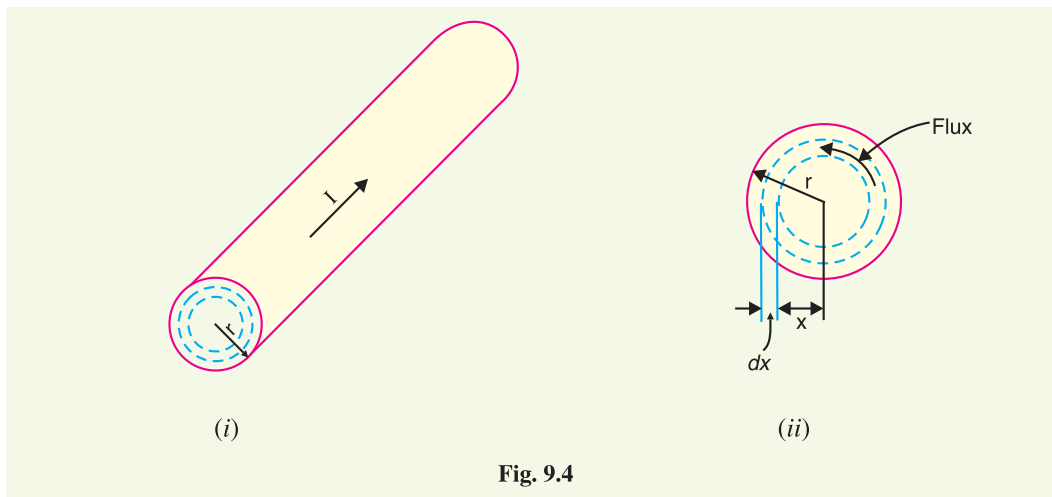

Fig. 9.4

\* According to Ampere's law, m.m.f. (ampere-turns) around any closed path equals the current enclosed by the path. The current enclosed by the path is  $I_x$  and m.m.f. =  $H_x \times 2\pi x$ .  $\therefore H_x \times 2\pi x = I_x$ .

If  $\mu$  ( $= \mu_0 \mu_r$ ) is the permeability of the conductor, then flux density at the considered point is given by;

$$\begin{aligned} B_x &= \mu_0 \mu_r H_x \text{ wb/m}^2 \\ &= \frac{\mu_0 \mu_r x}{2 \pi r^2} I = \frac{\mu_0 x I}{2 \pi r^2} \text{ wb/m}^2 [\because \mu_r = 1 \text{ for non-magnetic material}] \end{aligned}$$

Now, flux  $d\phi$  through a cylindrical shell of radial thickness  $dx$  and axial length 1 m is given by;

$$d\phi = B_x \times 1 \times dx = \frac{\mu_0 x I}{2 \pi r^2} dx \text{ weber}$$

This flux links with current  $I_x \left( = \frac{I \pi x^2}{\pi r^2} \right)$  only. Therefore, flux linkages per metre length of the conductor is

$$d\psi = \frac{\pi x^2}{\pi r^2} d\phi = \frac{\mu_0 I x^3}{2 \pi r^4} dx \text{ weber-turns}$$

Total flux linkages from centre upto the conductor surface is

$$\begin{aligned} \Psi_{\text{int}} &= \int_0^r \frac{\mu_0 I x^3}{2 \pi r^4} dx \\ &= \frac{\mu_0 I}{8 \pi} \text{ weber-turns per metre length} \end{aligned}$$

**(ii) Flux linkages due to external flux.** Now let us calculate the flux linkages of the conductor due to external flux. The external flux extends from the surface of the conductor to infinity. Referring to Fig. 9.5, the field intensity at a distance  $x$  metres (from centre) outside the conductor is given by ;

$$H_x = \frac{I}{2 \pi x} \text{ AT/m}$$

$$\text{Flux density, } B_x = \mu_0 H_x = \frac{\mu_0 I}{2 \pi x} \text{ wb/m}^2$$

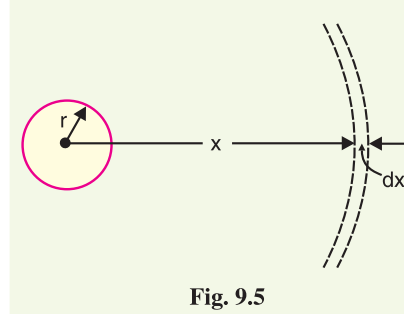

Fig. 9.5

Now, flux  $d\phi$  through a cylindrical shell of thickness  $dx$  and axial length 1 metre is

$$d\phi = B_x dx = \frac{\mu_0 I}{2 \pi x} dx \text{ webers}$$

The flux  $d\phi$  links all the current in the conductor once and only once.

$$\therefore \text{ Flux linkages, } d\psi = d\phi = \frac{\mu_0 I}{2 \pi x} dx \text{ weber-turns}$$

Total flux linkages of the conductor from surface to infinity,

$$\Psi_{\text{ext}} = \int_r^{\infty} \frac{\mu_0 I}{2 \pi x} dx \text{ weber-turns}$$

$$\therefore \text{ Overall flux linkages, } \Psi = \Psi_{\text{int}} + \Psi_{\text{ext}} = \frac{\mu_0 I}{8 \pi} + \int_r^{\infty} \frac{\mu_0 I}{2 \pi x} dx$$

$$\therefore \Psi = \frac{\mu_0 I}{2 \pi} \left[ \frac{1}{4} + \int_r^{\infty} \frac{dx}{x} \right] \text{ wb-turns/m length}$$

**2. Flux linkages in parallel current-carrying conductors.** We shall now determine the flux linkages in a group of parallel current carrying conductors. Fig. 9.6 shows the conductors A, B, C etc. carrying currents  $I_A, I_B, I_C$  etc. Let us consider the flux linkages with one conductor, say conductor A. There will be flux linkages with conductor A due to its own current as discussed previously. Also there will be flux linkages with this conductor due to the mutual inductance effects of  $I_B, I_C, I_D$  etc. We shall now determine the total flux linkages with conductor A.

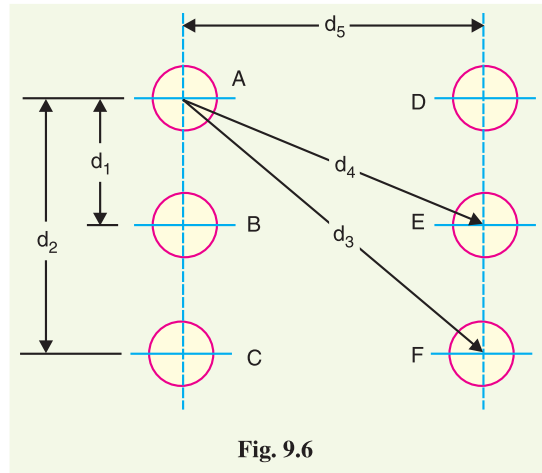

Fig. 9.6

Flux linkages with conductor A due to its own current

$$= \frac{\mu_0 I_A}{2\pi} \left[ \frac{1}{4} + \int_r^\infty \frac{dx}{x} \right] \quad \dots(i)$$

Flux linkages with conductor A due to current  $I_B$

$$= \frac{\mu_0 I_B}{2\pi} \int_{d_1}^\infty \frac{dx}{x} \quad \dots(ii)$$

Flux linkages with conductor A due to current  $I_C$

$$= \frac{\mu_0 I_C}{2\pi} \int_{d_2}^\infty \frac{dx}{x} \quad \dots(iii)$$

∴ Total flux linkages with conductor A

$$= (i) + (ii) + (iii) + \dots$$

$$= \frac{\mu_0 I_A}{2\pi} \left( \frac{1}{4} + \int_r^\infty \frac{dx}{x} \right) + \frac{\mu_0 I_B}{2\pi} \int_{d_1}^\infty \frac{dx}{x} + \frac{\mu_0 I_C}{2\pi} \int_{d_2}^\infty \frac{dx}{x} + \dots$$

Similarly, flux linkages with other conductors can be determined. The above relation provides the basis for evaluating inductance of any circuit.

### 9.5 Inductance of a Single Phase Two-wire Line

A single phase line consists of two parallel conductors which form a rectangular loop of one turn. When an alternating current flows through such a loop, a changing magnetic flux is set up. The changing flux links the loop and hence the loop (or single phase line) possesses inductance. It may appear that inductance of a single phase line is negligible because it consists of a loop of one turn and the flux path is through air of high reluctance. But as the X-sectional area of the loop is very large, even for a small flux density, the total flux linking the loop is quite large and hence the line has appreciable inductance.

\* The conductor B carrying current  $I_B$  is at a distance  $d_1$  from conductor A. Only the external flux due to  $I_B$  links with conductor A. This external flux due to  $I_B$  links with conductor A from  $d_1$  to  $\infty$  and hence the term

$$\frac{\mu_0 I_B}{2\pi} \int_{d_1}^\infty \frac{dx}{x}$$

\*\* The conductors are spaced several metres and the length of the line is several kilometres. Therefore, the loop has a large X-sectional area.

Consider a single phase overhead line consisting of two parallel conductors  $A$  and  $B$  spaced  $d$  metres apart as shown in Fig. 9.7. Conductors  $A$  and  $B$  carry the same amount of current (*i.e.*  $I_A = I_B$ ), but in the opposite direction because one forms the return circuit of the other.

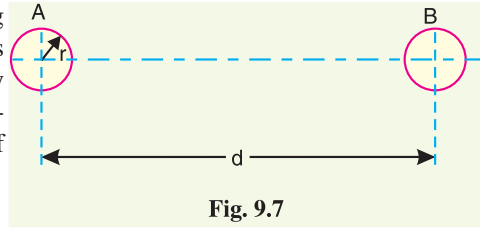

Fig. 9.7

$$\therefore I_A + I_B = 0$$

In order to find the inductance of conductor  $A$  (or conductor  $B$ ), we shall have to consider the flux linkages with it. There will be flux linkages with conductor  $A$  due to its own current  $I_A$  and also due to the mutual inductance effect of current  $I_B$  in the conductor  $B$ .

Flux linkages with conductor  $A$  due to its own current

$$= \frac{\mu_0 I_A}{2\pi} \left( \frac{1}{4} + \int_r^\infty \frac{dx}{x} \right) \quad \dots(i) \quad [\text{See Art. 9.4}]$$

Flux linkages with conductor  $A$  due to current  $I_B$

$$= \frac{\mu_0 I_B}{2\pi} \int_d^\infty \frac{dx}{x} \quad \dots(ii)$$

Total flux linkages with conductor  $A$  is

$$\begin{aligned} \Psi_A &= \text{exp. (i)} + \text{exp. (ii)} \\ &= \frac{\mu_0 I_A}{2\pi} \left( \frac{1}{4} + \int_r^\infty \frac{dx}{x} \right) + \frac{\mu_0 I_B}{2\pi} \int_d^\infty \frac{dx}{x} \\ &= \frac{\mu_0}{2\pi} \left[ \left( \frac{1}{4} + \int_r^\infty \frac{dx}{x} \right) I_A + I_B \int_d^\infty \frac{dx}{x} \right] \\ &= \frac{\mu_0}{2\pi} \left[ \left( \frac{1}{4} + \log_e \infty - \log_e r \right) I_A + (\log_e \infty - \log_e d) I_B \right] \\ &= \frac{\mu_0}{2\pi} \left[ \left( \frac{I_A}{4} + \log_e \infty (I_A + I_B) - I_A \log_e r - I_B \log_e d \right) \right] \\ &= \frac{\mu_0}{2\pi} \left[ \frac{I_A}{4} - I_A \log_e r - I_B \log_e d \right] \quad (\because I_A + I_B = 0) \end{aligned}$$

Now,

$$I_A + I_B = 0 \quad \text{or} \quad -I_B = I_A$$

$$\therefore -I_B \log_e d = I_A \log_e d$$

$$\begin{aligned} \therefore \Psi_A &= \frac{\mu_0}{2\pi} \left[ \frac{I_A}{4} + I_A \log_e d - I_A \log_e r \right] \text{wb-turns/m} \\ &= \frac{\mu_0}{2\pi} \left[ \frac{I_A}{4} + I_A \log_e \frac{d}{r} \right] \\ &= \frac{\mu_0 I_A}{2\pi} \left[ \frac{1}{4} + \log_e \frac{d}{r} \right] \text{wb-turns/m} \end{aligned}$$

$$\text{Inductance of conductor A, } L_A = \frac{\Psi_A}{I_A}$$

$$= \frac{\mu_0}{2\pi} \left[ \frac{1}{4} + \log_e \frac{d}{r} \right] \text{H/m} = \frac{4\pi \times 10^{-7}}{2\pi} \left[ \frac{1}{4} + \log_e \frac{d}{r} \right] \text{H/m}$$

$$\therefore L_A = 10^{-7} \left[ \frac{1}{2} + 2 \log_e \frac{d}{r} \right] \text{H/m} \quad \dots(i)$$

$$\text{Loop inductance} = 2 L_A \text{H/m} = 10^{-7} \left[ 1 + 4 \log_e \frac{d}{r} \right] \text{H/m}$$

$$\therefore \text{Loop inductance} = 10^{-7} \left[ 1 + 4 \log_e \frac{d}{r} \right] \text{H/m} \quad \dots(ii)$$

Note that eq. (ii) is the inductance of the two-wire line and is sometimes called loop inductance. However, inductance given by eq. (i) is the inductance per conductor and is equal to half the loop inductance.

**Expression in alternate form.** The expression for the inductance of a conductor can be put in a concise form.

$$\begin{aligned} L_A &= 10^{-7} \left[ \frac{1}{2} + 2 \log_e \frac{d}{r} \right] \text{H/m} \\ &= 2 \times 10^{-7} \left[ \frac{1}{4} + \log_e \frac{d}{r} \right] \\ &= 2 \times 10^{-7} \left[ \log_e e^{1/4} + \log_e \frac{d}{r} \right] \end{aligned}$$

$$\therefore L_A = 2 \times 10^{-7} \log_e \frac{d}{r e^{-1/4}}$$

If we put  $r e^{-1/4} = r'$ , then,

$$L_A = 2 \times 10^{-7} \log_e \frac{d}{r'} \text{H/m} \quad \dots(iii)$$

The radius  $r'$  is that of a fictitious conductor assumed to have no internal flux but with the same inductance as the actual conductor of radius  $r$ . The quantity  $e^{-1/4} = 0.7788$  so that

$$r' = r e^{-1/4} = 0.7788 r$$

The term  $r' (= r e^{-1/4})$  is called **geometric mean radius (GMR)** of the wire. Note that eq. (iii) gives the same value of inductance  $L_A$  as eq. (i). The difference is that eq. (iii) omits the term to account for internal flux but compensates for it by using an adjusted value of the radius of the conductor.

$$\text{Loop inductance} = 2 L_A = 2 \times 2 \times 10^{-7} \log_e \frac{d}{r'} \text{H/m}$$

Note that  $r' = 0.7788 r$  is applicable to only solid round conductor.

## 9.6 Inductance of a 3-Phase Overhead Line

Fig. 9-8 shows the three conductors A, B and C of a 3-phase line carrying currents  $I_A$ ,  $I_B$  and  $I_C$  respectively. Let  $d_1$ ,  $d_2$  and  $d_3$  be the spacings between the conductors as shown. Let us further assume that the loads are balanced i.e.  $I_A + I_B + I_C = 0$ . Consider the flux linkages with conductor A. There will be flux linkages with conductor A due to its own current and also due to the mutual inductance effects of  $I_B$  and  $I_C$ .

Flux linkages with conductor A due to its own current

$$= \frac{\mu_0 I_A}{2\pi} \left( \frac{1}{4} + \int_r^\infty \frac{dx}{x} \right) \quad \dots(i)$$

Flux linkages with conductor A due to current  $I_B$

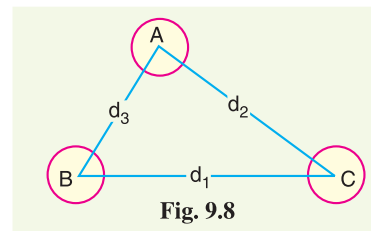

Fig. 9.8



$$= \frac{\mu_0 I_B}{2\pi} \int_{d_3}^{\infty} \frac{dx}{x} \quad \dots(ii)$$

Flux linkages with conductor A due to current  $I_C$

$$= \frac{\mu_0 I_C}{2\pi} \int_{d_2}^{\infty} \frac{dx}{x} \quad \dots(iii)$$

Total flux linkages with conductor A is

$$\begin{aligned} \Psi_A &= (i) + (ii) + (iii) \\ &= \frac{\mu_0 I_A}{2\pi} \left( \frac{1}{4} + \int_r^{\infty} \frac{dx}{x} \right) + \frac{\mu_0 I_B}{2\pi} \int_{d_3}^{\infty} \frac{dx}{x} + \frac{\mu_0 I_C}{2\pi} \int_{d_2}^{\infty} \frac{dx}{x} \\ &= \frac{\mu_0}{2\pi} \left[ \left( \frac{1}{4} + \int_r^{\infty} \frac{dx}{x} \right) I_A + I_B \int_{d_3}^{\infty} \frac{dx}{x} + I_C \int_{d_2}^{\infty} \frac{dx}{x} \right] \\ &= \frac{\mu_0}{2\pi} \left[ \left( \frac{1}{4} - \log_e r \right) I_A - I_B \log_e d_3 - I_C \log_e d_2 + \log_e \infty (I_A + I_B + I_C) \right] \end{aligned}$$

As  $I_A + I_B + I_C = 0$ ,

$$\therefore \Psi_A = \frac{\mu_0}{2\pi} \left[ \left( \frac{1}{4} - \log_e r \right) I_A - I_B \log_e d_3 - I_C \log_e d_2 \right]$$

**(i) Symmetrical spacing.** If the three conductors A, B and C are placed symmetrically at the corners of an equilateral triangle of side  $d$ , then,  $d_1 = d_2 = d_3 = d$ . Under such conditions, the flux linkages with conductor A become :

$$\begin{aligned} \Psi_A &= \frac{\mu_0}{2\pi} \left[ \left( \frac{1}{4} - \log_e r \right) I_A - I_B \log_e d - I_C \log_e d \right] \\ &= \frac{\mu_0}{2\pi} \left[ \left( \frac{1}{4} - \log_e r \right) I_A - (I_B + I_C) \log_e d \right] \\ &= \frac{\mu_0}{2\pi} \left[ \left( \frac{1}{4} - \log_e r \right) I_A + I_A \log_e d \right] \quad (\because I_B + I_C = -I_A) \\ &= \frac{\mu_0 I_A}{2\pi} \left[ \frac{1}{4} + \log_e \frac{d}{r} \right] \text{ weber-turns/m} \end{aligned}$$

$$\text{Inductance of conductor A, } L_A = \frac{\Psi_A}{I_A} \text{ H/m} = \frac{\mu_0}{2\pi} \left[ \frac{1}{4} + \log_e \frac{d}{r} \right] \text{ H/m}$$

$$= \frac{4\pi \times 10^{-7}}{2\pi} \left[ \frac{1}{4} + \log_e \frac{d}{r} \right] \text{ H/m}$$

$$\therefore L_A = 10^{-7} \left[ 0.5 + 2 \log_e \frac{d}{r} \right] \text{ H/m}$$

Derived in a similar way, the expressions for inductance are the same for conductors B and C.

**(ii) Unsymmetrical spacing.** When 3-phase line conductors are not equidistant from each other, the conductor spacing is said to be unsymmetrical. Under such conditions, the flux linkages and inductance of each phase are not the same. A different inductance in each phase results in unequal voltage drops in the three phases even if the currents in the conductors are balanced. Therefore, the voltage at the receiving end will not be the same for all phases. In order that voltage drops are equal in all conductors, we generally interchange the positions of the conductors at regular intervals along the line so that each conductor occupies the original position of every other conductor over an equal distance. Such an exchange of positions is known as *transposition*. Fig. 9.9 shows the

transposed line. The phase conductors are designated as  $A$ ,  $B$  and  $C$  and the positions occupied are numbered 1, 2 and 3. The effect of transposition is that each conductor has the same average inductance.

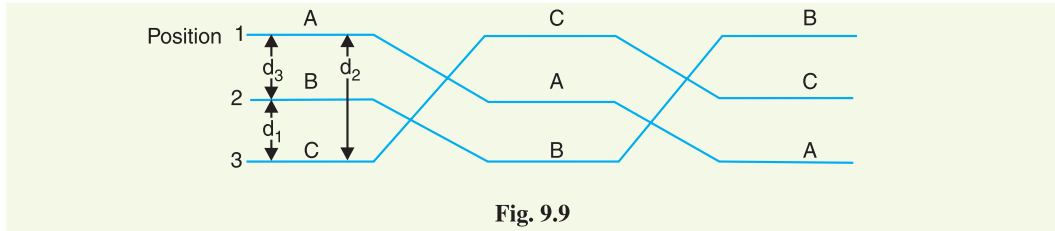

Fig. 9.9

Fig. 9.9 shows a 3-phase transposed line having unsymmetrical spacing. Let us assume that each of the three sections is 1 m in length. Let us further assume balanced conditions *i.e.*,  $I_A + I_B + I_C = 0$ . Let the line currents be :

$$\begin{aligned} I_A &= I(1 + j0) \\ I_B &= I(-0.5 - j0.866) \\ I_C &= I(-0.5 + j0.866) \end{aligned}$$

As proved above, the total flux linkages per metre length of conductor A is

$$\Psi_A = \frac{\mu_0}{2\pi} \left[ \left( \frac{1}{4} - \log_e r \right) I_A - I_B \log_e d_3 - I_C \log_e d_2 \right]$$

Putting the values of  $I_A$ ,  $I_B$  and  $I_C$ , we get,

$$\begin{aligned} \Psi_A &= \frac{\mu_0}{2\pi} \left[ \left( \frac{1}{4} - \log_e r \right) I - I(-0.5 - j0.866) \log_e d_3 - I(-0.5 + j0.866) \log_e d_2 \right] \\ &= \frac{\mu_0}{2\pi} \left[ \frac{1}{4} I - I \log_e r + 0.5 I \log_e d_3 + j0.866 I \log_e d_3 + 0.5 I \log_e d_2 - j0.866 I \log_e d_2 \right] \\ &= \frac{\mu_0}{2\pi} \left[ \frac{1}{4} I - I \log_e r + 0.5 I (\log_e d_3 + \log_e d_2) + j0.866 I (\log_e d_3 - \log_e d_2) \right] \\ &= \frac{\mu_0}{2\pi} \left[ \frac{1}{4} I - I \log_e r + I^* \log_e \sqrt{d_2 d_3} + j0.866 I \log_e \frac{d_3}{d_2} \right] \\ &= \frac{\mu_0}{2\pi} \left[ \frac{1}{4} I + I \log_e \frac{\sqrt{d_2 d_3}}{r} + j0.866 I \log_e \frac{d_3}{d_2} \right] \\ &= \frac{\mu_0 I}{2\pi} \left[ \frac{1}{4} + \log_e \frac{\sqrt{d_2 d_3}}{r} + j0.866 \log_e \frac{d_3}{d_2} \right] \end{aligned}$$

$\therefore$  Inductance of conductor A is

$$\begin{aligned} L_A &= \frac{\Psi_A}{I_A} = \frac{\Psi_A}{I} \\ &= \frac{\mu_0}{2\pi} \left[ \frac{1}{4} + \log_e \frac{\sqrt{d_2 d_3}}{r} + j0.866 \log_e \frac{d_3}{d_2} \right] \end{aligned}$$

\*  $0.5 I (\log_e d_3 + \log_e d_2) = 0.5 I \log_e d_2 d_3 = I \log_e (d_2 d_3)^{0.5} = I \log_e \sqrt{d_2 d_3}$

$$= \frac{4\pi \times 10^{-7}}{2\pi} \left[ \frac{1}{4} + \log_e \frac{\sqrt{d_2 d_3}}{r} + j 0.866 \log_e \frac{d_3}{d_2} \right] \text{H/m}$$

$$= 10^{-7} \left[ \frac{1}{2} + 2 \log_e \frac{\sqrt{d_2 d_3}}{r} + j 1.732 \log_e \frac{d_3}{d_2} \right] \text{H/m}$$

Similarly inductance of conductors B and C will be :

$$L_B = 10^{-7} \left[ \frac{1}{2} + 2 \log_e \frac{\sqrt{d_3 d_1}}{r} + j 1.732 \log_e \frac{d_1}{d_3} \right] \text{H/m}$$

$$L_C = 10^{-7} \left[ \frac{1}{2} + 2 \log_e \frac{\sqrt{d_1 d_2}}{r} + j 1.732 \log_e \frac{d_2}{d_1} \right] \text{H/m}$$

Inductance of each line conductor

$$= \frac{1}{3} (L_A + L_B + L_C)$$

$$= * \left[ \frac{1}{2} + 2 \log_e \frac{\sqrt[3]{d_1 d_2 d_3}}{r} \right] \times 10^{-7} \text{H/m}$$

$$= \left[ 0.5 + 2 \log_e \frac{\sqrt[3]{d_1 d_2 d_3}}{r} \right] \times 10^{-7} \text{H/m}$$

If we compare the formula of inductance of an unsymmetrically spaced transposed line with that of symmetrically spaced line, we find that inductance of each line conductor in the two cases will be equal if  $d = \sqrt[3]{d_1 d_2 d_3}$ . The distance  $d$  is known as *equivalent equilateral spacing* for unsymmetrically transposed line.

## 9.7 Concept of Self-GMD and Mutual-GMD

The use of *self geometrical mean distance* (abbreviated as self-GMD) and *mutual geometrical mean distance* (mutual-GMD) simplifies the inductance calculations, particularly relating to multiconductor arrangements. The symbols used for these are respectively  $D_s$  and  $D_m$ . We shall briefly discuss these terms.

**(i) Self-GMD ( $D_s$ ).** In order to have concept of self-GMD (also sometimes called Geometrical mean radius ; GMR), consider the expression for inductance per conductor per metre already derived in Art. 9.5

$$\begin{aligned} \text{Inductance/conductor/m} &= 2 \times 10^{-7} \left( \frac{1}{4} + \log_e \frac{d}{r} \right) \\ &= 2 \times 10^{-7} \times \frac{1}{4} + 2 \times 10^{-7} \log_e \frac{d}{r} \end{aligned} \quad \dots(i)$$

In this expression, the term  $2 \times 10^{-7} \times (1/4)$  is the inductance due to flux within the solid conductor. For many purposes, it is desirable to eliminate this term by the introduction of a concept called self-GMD or GMR. If we replace the original solid conductor by an equivalent hollow cylinder with extremely thin walls, the current is confined to the conductor surface and internal conductor flux linkage would be almost zero. Consequently, inductance due to internal flux would be zero and the term  $2 \times 10^{-7} \times (1/4)$  shall be eliminated. The radius of this equivalent hollow cylinder must be sufficiently smaller than the physical radius of the conductor to allow room for enough additional flux

\* On solving.

to compensate for the absence of internal flux linkage. It can be proved mathematically that for a solid round conductor of radius  $r$ , the self-GMD or GMR =  $0.7788 r$ . Using self-GMD, the eq. (i) becomes :

$$\text{Inductance/conductor/m} = 2 \times 10^{-7} \log_e d/D_s^*$$

where  $D_s = \text{GMR or self-GMD} = 0.7788 r$

It may be noted that self-GMD of a conductor depends upon the size and shape of the conductor and is independent of the spacing between the conductors.

**(ii) Mutual-GMD.** The mutual-GMD is the geometrical mean of the distances from one conductor to the other and, therefore, must be between the largest and smallest such distance. In fact, mutual-GMD simply represents the equivalent geometrical spacing.

**(a)** The mutual-GMD between two conductors (assuming that spacing between conductors is large compared to the diameter of each conductor) is equal to the distance between their centres *i.e.*

$$D_m = \text{spacing between conductors} = d$$

**(b)** For a single circuit 3- $\phi$  line, the mutual-GMD is equal to the equivalent equilateral spacing *i.e.*,  $(d_1 d_2 d_3)^{1/3}$ .

$$D_m = (d_1 d_2 d_3)^{1/3}$$

**(c)** The principle of geometrical mean distances can be most profitably employed to 3- $\phi$  double circuit lines. Consider the conductor arrangement of the double circuit shown in Fig. 9.10. Suppose the radius of each conductor is  $r$ .

Self-GMD of conductor =  $0.7788 r$

Self-GMD of combination  $aa'$  is

$$D_{s1} = (*D_{aa} \times D_{aa'} \times D_{a'a} \times D_{a'a'})^{1/4}$$

Self-GMD of combination  $bb'$  is

$$D_{s2} = (D_{bb} \times D_{bb'} \times D_{b'b} \times D_{b'b'})^{1/4}$$

Self-GMD of combination  $cc'$  is

$$D_{s3} = (D_{cc} \times D_{cc'} \times D_{c'c} \times D_{c'c'})^{1/4}$$

Equivalent self-GMD of one phase

$$D_s = (D_{s1} \times D_{s2} \times D_{s3})^{1/3}$$

The value of  $D_s$  is the same for all the phases as each conductor has the same radius.

Mutual-GMD between phases A and B is

$$D_{AB} = (D_{ab} \times D_{ab'} \times D_{a'b} \times D_{a'b'})^{1/4}$$

Mutual-GMD between phases B and C is

$$D_{BC} = (D_{bc} \times D_{bc'} \times D_{b'c} \times D_{b'c'})^{1/4}$$

Mutual-GMD between phases C and A is

$$D_{CA} = (D_{ca} \times D_{ca'} \times D_{c'a} \times D_{c'a'})^{1/4}$$

Equivalent mutual-GMD,  $D_m = (D_{AB} \times D_{BC} \times D_{CA})^{1/3}$

It is worthwhile to note that mutual GMD depends only upon the spacing and is substantially independent of the exact size, shape and orientation of the conductor.

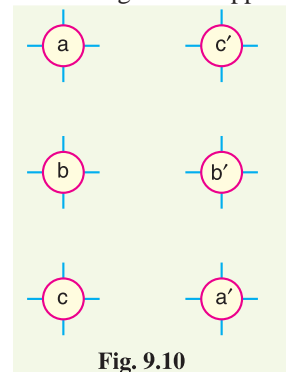

Fig. 9.10

## 9.8 Inductance Formulas in Terms of GMD

The inductance formulas developed in the previous articles can be conveniently expressed in terms of geometrical mean distances.

\* Basically, we have omitted the internal flux term while compensating for it by using an adjusted value for the radius of the conductor. Sometimes GMR is denoted by  $r'$ .

\*\*  $D_{aa}$  or  $D_{a'a'}$  means self-GMD of the conductor.  $D_{aa'}$  means distance between  $a$  and  $a'$ .

**(i) Single phase line**

$$\text{Inductance/conductor/m} = 2 \times 10^{-7} \log_e \frac{D_m}{D_s}$$

where  $D_s = 0.7788 r$  and  $D_m = \text{Spacing between conductors} = d$

**(ii) Single circuit 3- $\phi$  line**

$$\text{Inductance/phase/m} = 2 \times 10^{-7} \log_e \frac{D_m}{D_s}$$

where  $D_s = 0.7788 r$  and  $D_m = (d_1 d_2 d_3)^{1/3}$

**(iii) Double circuit 3- $\phi$  line**

$$\text{Inductance/phase/m} = 2 \times 10^{-7} \log_e \frac{D_m}{D_s}$$

where  $D_s = (D_{s1} D_{s2} D_{s3})^{1/3}$  and  $D_m = (D_{AB} \times D_{BC} \times D_{CA})^{1/3}$

**Example 9.1.** A single phase line has two parallel conductors 2 metres apart. The diameter of each conductor is 1.2 cm. Calculate the loop inductance per km of the line.

**Solution.**

Spacing of conductors,  $d = 2 \text{ m} = 200 \text{ cm}$

Radius of conductor,  $r = 1.2/2 = 0.6 \text{ cm}$

$$\begin{aligned} \text{Loop inductance per metre length of the line} \\ &= 10^{-7} (1 + 4 \log_e d/r) \text{ H} \\ &= 10^{-7} (1 + 4 \log_e 200/0.6) \text{ H} \\ &= 24.23 \times 10^{-7} \text{ H} \end{aligned}$$

Loop inductance per km of the line

$$= 24.23 \times 10^{-7} \times 1000 = 24.23 \times 10^{-4} \text{ H} = \mathbf{2.423 \text{ mH}}$$



Inductance Measurement using bridge

**Example 9.2.** A single phase transmission line has two parallel conductors 3 m apart, the radius of each conductor being 1 cm. Calculate the loop inductance per km length of the line if the material of the conductor is (i) copper (ii) steel with relative permeability of 100.

**Solution.**

Spacing of conductors,  $d = 300 \text{ cm}$

Radius of conductor,  $r = 1 \text{ cm}$

Loop inductance  $= 10^{-7} (\mu_r + 4 \log_e d/r) \text{ H/m}$

**(i)** With copper conductors,  $\mu_r = 1$

$$\begin{aligned} \therefore \text{Loop inductance/m} \\ &= 10^{-7} (1 + 4 \log_e d/r) \text{ H} = 10^{-7} (1 + 4 \log_e 300/1) \text{ H} \\ &= 23.8 \times 10^{-7} \text{ H} \end{aligned}$$

Loop inductance/km  $= 23.8 \times 10^{-7} \times 1000 = 2.38 \times 10^{-3} \text{ H} = \mathbf{2.38 \text{ mH}}$

**(ii)** With steel conductors,  $\mu_r = 100$

$$\therefore \text{Loop inductance/m} = 10^{-7} (100 + 4 \log_e 300/1) \text{ H} = 122.8 \times 10^{-7} \text{ H}$$

Loop inductance/km  $= 122.8 \times 10^{-7} \times 1000 = 12.28 \times 10^{-3} \text{ H} = \mathbf{12.28 \text{ mH}}$

**Example 9.3.** Find the inductance per km of a 3-phase transmission line using 1.24 cm diameter conductors when these are placed at the corners of an equilateral triangle of each side 2 m.

**Solution.** Fig. 9.11 shows the three conductors of the three phase line placed at the corners of an equilateral triangle of each side 2 m. Here conductor spacing  $d = 2$  m and conductor radius  $r = 1.24/2 = 0.62$  cm.

$$\begin{aligned}\text{Inductance/phase/m} &= 10^{-7} (0.5 + 2 \log_e d/r) \text{ H} \\ &= 10^{-7} (0.5 + 2 \log_e 200/0.62) \text{ H} \\ &= 12 \times 10^{-7} \text{ H} \\ \text{Inductance/phase/km} &= 12 \times 10^{-7} \times 1000 \\ &= 1.2 \times 10^{-3} \text{ H} = \mathbf{1.2 \text{ mH}}\end{aligned}$$

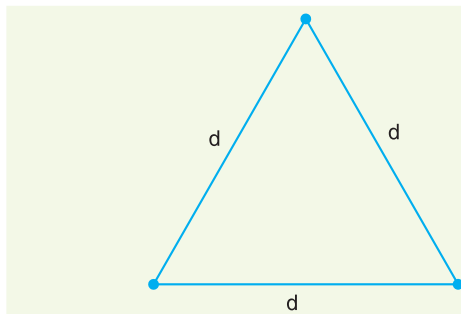

Fig. 9.11

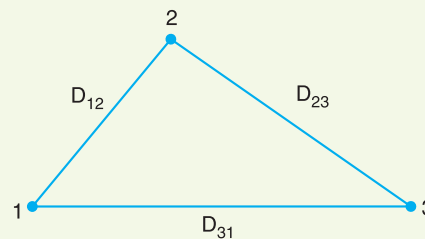

Fig. 9.12

**Example 9.4.** The three conductors of a 3-phase line are arranged at the corners of a triangle of sides 2 m, 2.5 m and 4.5 m. Calculate the inductance per km of the line when the conductors are regularly transposed. The diameter of each conductor is 1.24 cm.

**Solution.** Fig. 9.12 shows three conductors of a 3-phase line placed at the corners of a triangle of sides  $D_{12} = 2$  m,  $D_{23} = 2.5$  m and  $D_{31} = 4.5$  m. The conductor radius  $r = 1.24/2 = 0.62$  cm.

$$\begin{aligned}\text{Equivalent equilateral spacing, } D_{eq} &= \sqrt[3]{D_{12} \times D_{23} \times D_{31}} = \sqrt[3]{2 \times 2.5 \times 4.5} = 2.82 \text{ m} = 282 \text{ cm} \\ \text{Inductance/phase/m} &= 10^{-7} (0.5 + 2 \log_e D_{eq}/r) \text{ H} = 10^{-7} (0.5 + 2 \log_e 282/0.62) \text{ H} \\ &= 12.74 \times 10^{-7} \text{ H} \\ \text{Inductance/phase/km} &= 12.74 \times 10^{-7} \times 1000 = 1.274 \times 10^{-3} \text{ H} = \mathbf{1.274 \text{ mH}}\end{aligned}$$

**Example 9.5.** Calculate the inductance of each conductor in a 3-phase, 3-wire system when the conductors are arranged in a horizontal plane with spacing such that  $D_{31} = 4$  m;  $D_{12} = D_{23} = 2$  m. The conductors are transposed and have a diameter of 2.5 cm.

**Solution.** Fig. 9.13 shows the arrangement of the conductors of the 3-phase line. The conductor radius  $r = 2.5/2 = 1.25$  cm.

$$\text{Equivalent equilateral spacing, } D_{eq} = \sqrt[3]{D_{12} \times D_{23} \times D_{31}} = \sqrt[3]{2 \times 2 \times 4} = 2.52 \text{ m} = 252 \text{ cm}$$

$$\begin{aligned}\text{Inductance/phase/m} &= 10^{-7} (0.5 + 2 \log_e D_{eq}/r) \text{ H} \\ &= 10^{-7} (0.5 + 2 \log_e 252/1.25) \text{ H} \\ &= 11.1 \times 10^{-7} \text{ H} \\ \text{Inductance/phase/km} &= 11.1 \times 10^{-7} \times 1000 \\ &= 1.11 \times 10^{-3} \text{ H} = \mathbf{1.11 \text{ mH}}\end{aligned}$$

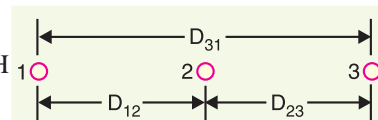

Fig. 9.13

**Example 9.6.** Two conductors of a single phase line, each of 1 cm diameter, are arranged in a vertical plane with one conductor mounted 1 m above the other. A second identical line is mounted at the same height as the first and spaced horizontally 0.25 m apart from it. The two upper and the two lower conductors are connected in parallel. Determine the inductance per km of the resulting double circuit line.

**Solution.** Fig. 9.14. shows the arrangement of double circuit single phase line. Conductors  $a, a'$  form one connection and conductors  $b, b'$  form the return connection. The conductor radius,  $r = 1/2 = 0.5$  cm.

$$\text{G.M.R. of conductor} = 0.7788 r = 0.7788 \times 0.5 = 0.389 \text{ cm}$$

Self G.M.D. of  $aa'$  combination is

$$\begin{aligned} D_s &= \sqrt[4]{D_{aa} \times D_{aa'} \times D_{a'a'} \times D_{a'a}} \\ &= \sqrt[4]{(0.389 \times 100)^2} = 6.23 \text{ cm} \end{aligned}$$

Mutual G.M.D. between  $a$  and  $b$  is

$$\begin{aligned} D_m &= \sqrt[4]{D_{ab} \times D_{ab'} \times D_{a'b} \times D_{a'b'}} \\ &= \sqrt[4]{(25 \times 103 \times 103 \times 25)} = 50.74 \text{ cm} \\ [\because D_{ab'} = D_{a'b} = \sqrt{25^2 + 100^2} = 103 \text{ cm}] \end{aligned}$$

Inductance per conductor per metre

$$\begin{aligned} &= 2 \times 10^{-7} \log_e D_m / D_s = 2 \times 10^{-7} \log_e 50.74 / 6.23 \text{ H} \\ &= 0.42 \times 10^{-6} \text{ H} \end{aligned}$$

$\therefore$  Loop inductance per km of the line

$$= 2 \times 0.42 \times 10^{-6} \times 1000 \text{ H} = \mathbf{0.84 \text{ mH}}$$

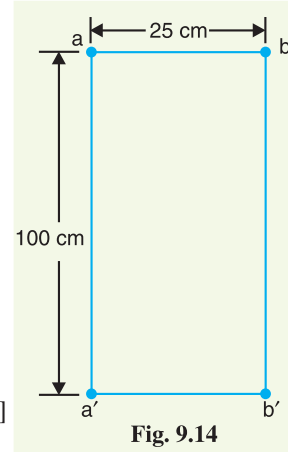

Fig. 9.14

**Example 9.7.** Fig. 9.15 shows the spacings of a double circuit 3-phase overhead line. The phase sequence is ABC and the line is completely transposed. The conductor radius is 1.3 cm. Find the inductance per phase per kilometre.

**Solution.**

$$\text{G.M.R. of conductor} = 1.3 \times 0.7788 = 1.01 \text{ cm}$$

$$\text{Distance } a \text{ to } b' = \sqrt{6^2 + 3^2} = 6.7 \text{ m}$$

$$\text{Distance } a \text{ to } a' = \sqrt{6^2 + 6^2} = 8.48 \text{ m}$$

Equivalent self G.M.D. of one phase is

$$D_s = \sqrt[3]{D_{s1} \times D_{s2} \times D_{s3}}$$

where  $D_{s1}, D_{s2}$  and  $D_{s3}$  represent the self-G.M.D. in positions 1, 2 and 3 respectively. Also  $D_s$  is the same for all the phases.

$$\begin{aligned} \text{Now } D_{s1} &= \sqrt[4]{D_{aa} \times D_{aa'} \times D_{a'a'} \times D_{a'a}} \\ &= \sqrt[4]{(1.01 \times 10^{-2}) \times (8.48) \times (1.01 \times 10^{-2}) \times (8.48)} \\ &= 0.292 \text{ m} = D_{s3} \end{aligned}$$

$$\begin{aligned} D_{s2} &= \sqrt[4]{D_{bb} \times D_{bb'} \times D_{b'b'} \times D_{b'b}} \\ &= \sqrt[4]{(1.01 \times 10^{-2}) \times (6) \times (1.01 \times 10^{-2}) \times (6)} = 0.246 \text{ m} \end{aligned}$$

$$D_s = \sqrt[3]{0.292 \times 0.246 \times 0.292} = 0.275 \text{ m}$$

$$\text{Equivalent mutual G.M.D., } D_m = \sqrt[3]{D_{AB} \times D_{BC} \times D_{CA}}$$

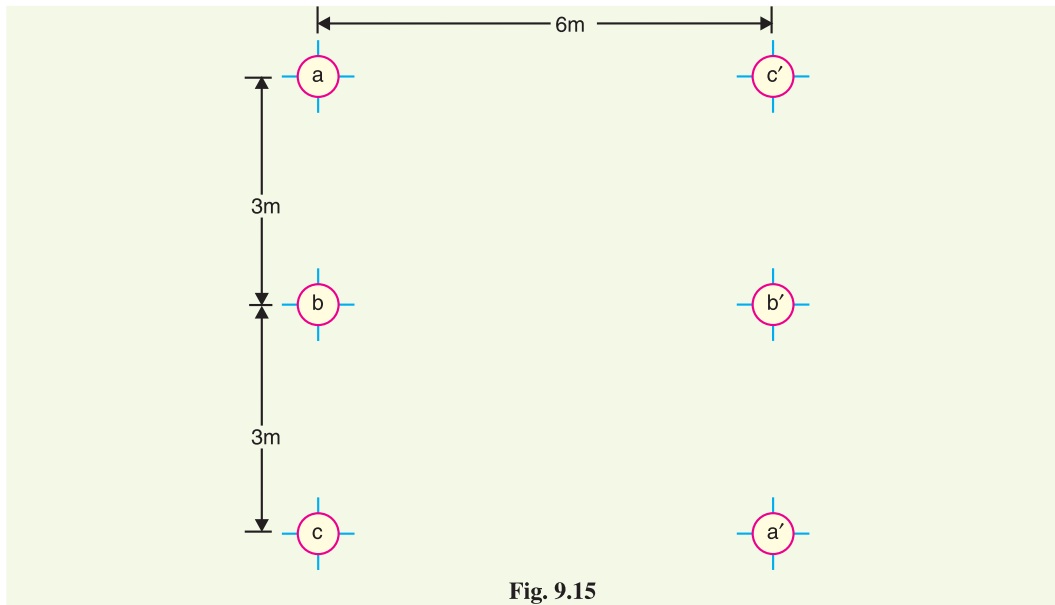

Fig. 9.15

where  $D_{AB}$ ,  $D_{BC}$  and  $D_{CA}$  represent the mutual G.M.D. between phases A and B, B and C and C and A respectively.

$$\begin{aligned} \text{Now} \quad D_{AB} &= \sqrt[4]{D_{ab} \times D_{ab'} \times D_{a'b} \times D_{a'b'}} = \sqrt[4]{3 \times 6.7 \times 6.7 \times 3} \\ &= 4.48 \text{ m} = D_{BC} \end{aligned}$$

$$D_{CA} = \sqrt[4]{D_{ca} \times D_{ca'} \times D_{c'a} \times D_{c'a'}} = \sqrt[4]{6 \times 6 \times 6 \times 6} = 6 \text{ m}$$

$$\therefore D_m = \sqrt[3]{4.48 \times 4.48 \times 6} = 4.94 \text{ m}$$

$\therefore$  Inductance per phase per metre length

$$\begin{aligned} &= 10^{-7} \times 2 \log_e D_m / D_s = 10^{-7} \times 2 \log_e 4.94 / 0.275 \\ &= 5.7 \times 10^{-7} \text{ H} \end{aligned}$$

$$\text{Inductance /phase/km} = 5.7 \times 10^{-7} \times 1000 = 0.57 \times 10^{-3} \text{ H} = \mathbf{0.57 \text{ mH}}$$

**Example 9.8.** Find the inductance per phase per km of double circuit 3-phase line shown in Fig. 9.16. The conductors are transposed and are of radius 0.75 cm each. The phase sequence is ABC.

**Solution.**

$$\text{G.M.R. of conductor} = 0.75 \times 0.7788 = 0.584 \text{ cm}$$

$$\text{Distance } a \text{ to } b = \sqrt{3^2 + (0.75)^2} = 3.1 \text{ m}$$

$$\text{Distance } a \text{ to } b' = \sqrt{3^2 + (4.75)^2} = 5.62 \text{ m}$$

$$\text{Distance } a \text{ to } a' = \sqrt{6^2 + 4^2} = 7.21 \text{ m}$$

Equivalent self G.M.D. of one phase is

$$D_s = \sqrt[3]{D_{s1} \times D_{s2} \times D_{s3}}$$

$$\text{where } D_{s1} = \sqrt[4]{D_{aa} \times D_{aa'} \times D_{a'a'} \times D_{a'a}}$$



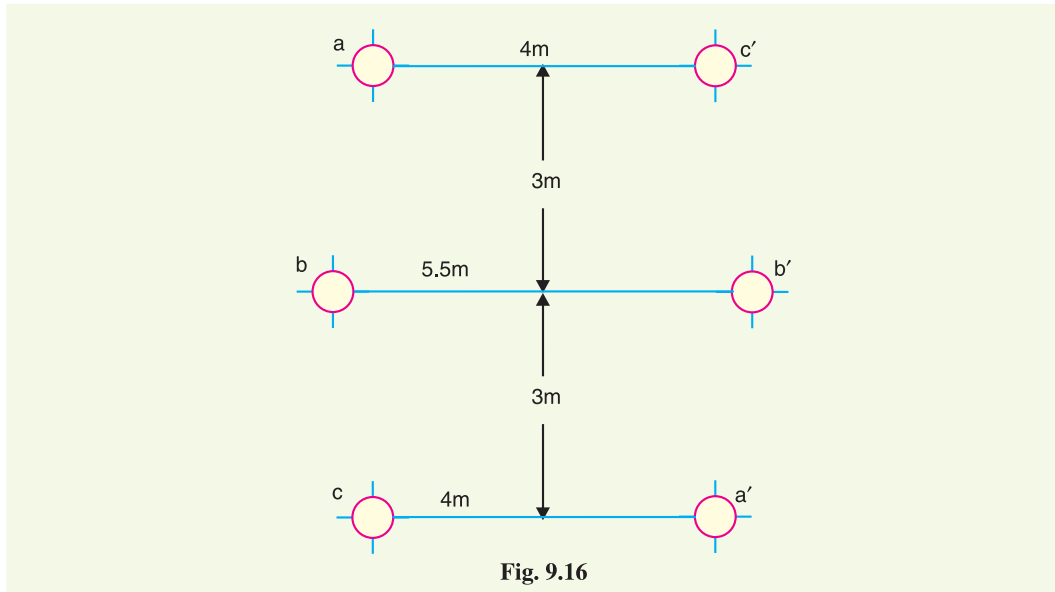

Fig. 9.16

$$= \sqrt[4]{(0.584 \times 10^{-2}) \times (7.21) \times (0.584 \times 10^{-2}) \times (7.21)}$$

$$= 0.205 \text{ m} = D_{s3}$$

$$D_{s2} = \sqrt[4]{(D_{bb} \times D_{bb'} \times D_{b'b'} \times D_{b'b})}$$

$$= \sqrt[4]{(0.584 \times 10^{-2}) \times (5.5) \times (0.584 \times 10^{-2}) \times 5.5} = 0.18 \text{ m}$$

$$\therefore D_s = \sqrt[3]{0.205 \times 0.18 \times 0.205} = 0.195 \text{ m}$$

Equivalent mutual G.M.D. is

$$D_m = \sqrt[3]{D_{AB} \times D_{BC} \times D_{CA}}$$

$$\text{where } D_{AB} = \sqrt[4]{D_{ab} \times D_{ab'} \times D_{a'b} \times D_{a'b'}} = \sqrt[4]{3.1 \times 5.62 \times 5.62 \times 3.1}$$

$$= 4.17 \text{ m} = D_{BC}$$

$$D_{CA} = \sqrt[4]{D_{ca} \times D_{ca'} \times D_{c'a} \times D_{c'a'}}$$

$$= \sqrt[4]{6 \times 4 \times 4 \times 6} = 4.9 \text{ m}$$

$$\therefore D_m = \sqrt[3]{4.17 \times 4.17 \times 4.9} = 4.4 \text{ m}$$

$$\therefore \text{Inductance/phase/m} = 10^{-7} \times 2 \log_e D_m / D_s = 10^{-7} \times 2 \log_e 4.4 / 0.195 \text{ H}$$

$$= 6.23 \times 10^{-7} \text{ H} = 0.623 \times 10^{-3} \text{ mH}$$

$$\text{Inductance/phase/km} = 0.623 \times 10^{-3} \times 1000 = \mathbf{0.623 \text{ mH}}$$

**Example 9.9.** Calculate the inductance per phase per metre for a three-phase double-circuit line whose phase conductors have a radius of 5.3 cm with the horizontal conductor arrangement as shown in Fig. 9.17.

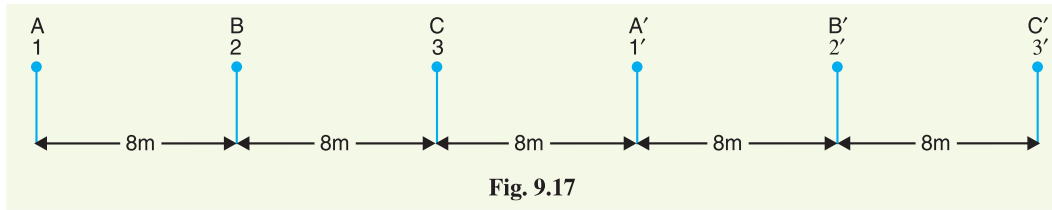

Fig. 9.17

**Solution.**

G.M.R. of conductor =  $0.7788 r = 0.7788 \times 5.3 \times 10^{-2} = 0.0413 \text{ m}$

Equivalent self-G.M.D. of one phase is

$$D_s = (D_{s1} \times D_{s2} \times D_{s3})^{1/3}$$

where  $D_{s1} = (D_{AA} \times D_{AA'} \times D_{A'A'} \times D_{A'A})^{1/4} = (0.0413 \times 24 \times 0.0413 \times 24)^{1/4} = 0.995 \text{ m}$

$D_{s2} = (D_{BB} \times D_{BB'} \times D_{B'B'} \times D_{B'B})^{1/4} = (0.0413 \times 24 \times 0.0413 \times 24)^{1/4} = 0.995 \text{ m}$

Similarly  $D_{s3} = 0.995 \text{ m}$

$\therefore D_s = \sqrt[3]{0.995 \times 0.995 \times 0.995} = 0.995 \text{ m}$

Equivalent mutual G.M.D. is

$$D_m = (D_{AB} \times D_{BC} \times D_{CA})^{1/3}$$

where  $D_{AB} = (D_{AB} \times D_{AB'} \times D_{A'B'} \times D_{A'B})^{1/4} = (8 \times 32 \times 16 \times 8)^{1/4} = 13.45 = D_{BC}$

$D_{CA} = (D_{CA} \times D_{CA'} \times D_{C'A'} \times D_{C'A})^{1/4} = (16 \times 8 \times 40 \times 16)^{1/4} = 16.917 \text{ m}$

$\therefore D_m = (13.45 \times 13.45 \times 16.917)^{1/3} = 14.518 \text{ m}$

Inductance/phase/m  
 $= 10^{-7} \times 2 \log_e D_m / D_s \text{ H/m}$   
 $= 10^{-7} \times 2 \log_e \frac{14.518}{0.995} \text{ H/m}$   
 $= 5.36 \times 10^{-7} \text{ H/m}$

**Example 9.10.** In a single phase line (See. Fig. 9.18), conductors a and a' in parallel form one circuit while conductors b and b' in parallel form the return path. Calculate the total inductance of the line per km assuming that current is equally shared by the two parallel conductors. Conductor diameter in 2.0 cm.

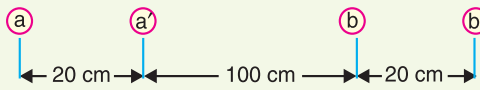

Fig. 9.18

**Solution.**

Loop inductance/km,  $L = 4 \times 10^{-4} \log_e \frac{D_m}{D_s} \text{ H/km}$

Mutual G.M.D.,  $D_m = \sqrt[4]{D_{ab} \times D_{ab'} \times D_{a'b'} \times D_{a'b}}$   
 $= \sqrt[4]{120 \times 140 \times 100 \times 120} = 119 \text{ cm}$

Self G.M.D.,  $D_s = \sqrt[4]{D_{aa} \times D_{aa'} \times D_{a'a'} \times D_{a'a}}$

Here  $D_{aa} = D_{a'a'} = 0.7788 \text{ cm}$ ;  $D_{aa'} = D_{a'a} = 20 \text{ cm}$

$\therefore D_s = \sqrt[4]{0.7788 \times 0.7788 \times 20 \times 20} = 3.94 \text{ cm}$

$\therefore L = 4 \times 10^{-4} \log_e \frac{119}{3.94} = 1.36 \times 10^{-3} \text{ H/km} = 1.36 \text{ mH/km}$

## TUTORIAL PROBLEMS

1. A single phase line has two parallel conductors 1 metre apart. The radius of each conductor is 0.5 cm. Calculate the loop inductance per km of the line. **[2.22 mH]**
  2. Find the inductance per km per phase of a 3-phase overhead transmission line using 2 cm diameter conductor when these are placed at the corners of an equilateral triangle of side 4 metres. **[1.25 mH]**
  3. Find the loop inductance per km of a single phase overhead transmission line when conductors have relative permeability of (i) 1 (ii) 100. Each conductor has a diameter of 1 cm and they are spaced 5 m apart. **[(i) 1.02 mH (ii) 10.9 mH]**
- Hint.** For a conductor of relative permeability  $\mu_r$  ( $= 100$  in the second case), loop inductance  

$$= (\mu_r + 4 \log_e d/r) \times 10^{-7} \text{ H/m}$$
4. A 20 km single phase line has two parallel conductors separated by 1.5 metres. The diameter of each conductor is 0.823 cm. If the conductor has a resistance of 0.311  $\Omega$ /km, find the loop impedance of this line at 50 Hz. **[19.86  $\Omega$ ]**
  5. The three conductors of a 3-phase line are arranged at the corners of a triangle of sides 4, 5 and 6 metres. Calculate inductance per km of the each conductor when conductors are regularly transposed. The diameter of each line conductor is 2 cm. **[1.285 mH]**
  6. The three conductors of 3-phase overhead line are arranged in a horizontal plane with a spacing of 4 m between adjacent conductors. The diameter of each conductor is 2 cm. Determine the inductance per km per phase of the line assuming that the lines are transposed. **[1.3 mH]**
  7. Determine the inductance per km of a 3-phase transmission line using 20 mm diameter conductors when conductors are at the corners of a triangle with spacing of 4, 5 and 6 metres. Conductors are regularly transposed. **[1.29 mH/km/phase]**
  8. Determine the inductance of a 3-phase symmetrical line whose conductors are placed at the corners of an equilateral triangle of sides 1 metre. The diameter of each conductor is 20 mm. **[0.971 mH/phase/km]**

## 9.9 Electric Potential

The electric potential at a point due to a charge is the work done in bringing a unit positive charge from infinity to that point. The concept of electric potential is extremely important for the determination of capacitance in a circuit since the latter is defined as the charge per unit potential. We shall now discuss in detail the electric potential due to some important conductor arrangements.

(i) **Potential at a charged single conductor.** Consider a long straight cylindrical conductor A of radius  $r$  metres. Let the conductor operate at such a potential ( $V_A$ ) that charge  $Q_A$  coulombs per metre exists on the conductor. It is desired to find the expression for  $V_A$ . The electric intensity  $E$  at a distance  $x$  from the centre of the conductor in air is given by:

$$E = \frac{Q_A}{2\pi x \epsilon_0} \text{ volts/m}$$

where

$Q_A$  = charge per metre length

$\epsilon_0$  = permittivity of free space

As  $x$  approaches infinity, the value of  $E$  approaches zero. Therefore, the potential difference between conductor A and infinity distant \* neutral plane is given by :

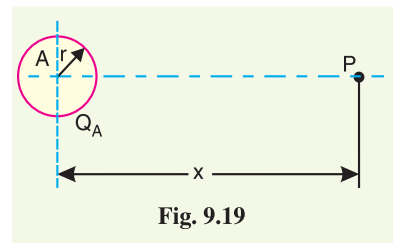

Fig. 9.19

\* A plane where  $E$  and hence potential is zero.

$$\dagger V_A = \int_r^\infty \frac{Q_A}{2\pi x \epsilon_0} dx = \frac{Q_A}{2\pi \epsilon_0} \int_r^\infty \frac{dx}{x}$$

**(ii) Potential at a conductor in a group of charged conductors.** Consider a group of long straight conductors  $A, B, C$  etc. operating at potentials such that charges  $Q_A, Q_B, Q_C$  etc. coulomb per metre length exist on the respective conductors (see Fig. 9.20). Let us find the potential at  $A$  (i.e.  $V_A$ ) in this arrangement. Potential at  $A$  due to its own charge (i.e.  $Q_A$ )

$$= \int_r^\infty \frac{Q_A}{2\pi x \epsilon_0} dx \quad \dots(i)$$

Potential at conductor  $A$  due to charge  $Q_B$

$$= \int_{d_1}^\infty \frac{* Q_B}{2\pi x \epsilon_0} dx \quad \dots(ii)$$

Potential at conductor  $A$  due to charge  $Q_C$

$$= \int_{d_2}^\infty \frac{Q_C}{2\pi x \epsilon_0} dx \quad \dots(iii)$$

Overall potential difference between conductor  $A$  and infinite neutral plane is

$$\begin{aligned} V_A &= (i) + (ii) + (iii) + \dots \\ &= \int_r^\infty \frac{Q_A}{2\pi x \epsilon_0} dx + \int_{d_1}^\infty \frac{Q_B}{2\pi x \epsilon_0} dx + \int_{d_2}^\infty \frac{Q_C}{2\pi x \epsilon_0} dx + \dots \\ &= \frac{1}{2\pi \epsilon_0} \left[ Q_A (\log_e \infty - \log_e r) + Q_B (\log_e \infty - \log_e d_1) \right. \\ &\quad \left. + Q_C (\log_e \infty - \log_e d_2) + \dots \right] \\ &= \frac{1}{2\pi \epsilon_0} \left[ Q_A \dagger\dagger \log_e \frac{1}{r} + Q_B \log_e \frac{1}{d_1} + Q_C \log_e \frac{1}{d_2} \right. \\ &\quad \left. + \log_e \infty (Q_A + Q_B + Q_C) + \dots \right] \end{aligned}$$

Assuming balanced conditions i.e.,  $Q_A + Q_B + Q_C = 0$ , we have,

$$V_A = \frac{1}{2\pi \epsilon_0} \left[ Q_A \log_e \frac{1}{r} + Q_B \log_e \frac{1}{d_1} + Q_C \log_e \frac{1}{d_2} + \dots \right]$$

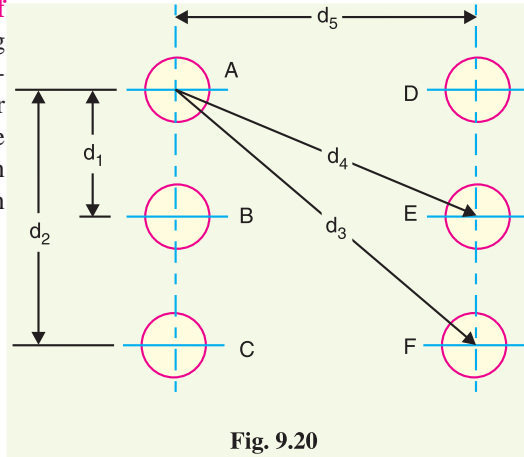

Fig. 9.20

† Note the expression. Work is done in bringing a unit positive charge against  $E$  from infinity to conductor surface.

\* Conductor  $B$  is  $d_1$  metres away from conductor  $A$ . Therefore, the work done in bringing a unit positive charge (due to charge  $Q_B$ ) from infinity to conductor  $A$  is

$$= \int_{d_1}^\infty \frac{Q_B}{2\pi x \epsilon_0} dx$$

††  $-\log_e r = \log_e (r)^{-1} = \log_e \frac{1}{r}$

### 9.10 Capacitance of a Single Phase Two-wire Line

Consider a single phase overhead transmission line consisting of two parallel conductors  $A$  and  $B$  spaced  $d$  metres apart in air. Suppose that radius of each conductor is  $r$  metres. Let their respective charge be  $+Q$  and  $-Q$  coulombs per metre length.

The total p.d. between conductor  $A$  and neutral “infinite” plane is

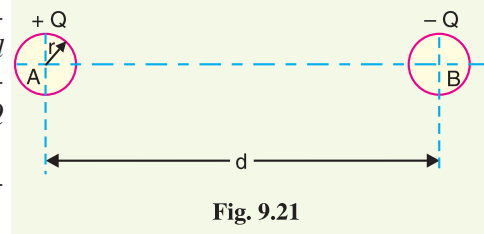

$$V_A = \int_r^{\infty} \frac{Q}{2\pi x \epsilon_0} dx + \int_d^{\infty} \frac{-Q}{2\pi x \epsilon_0} dx$$

$$= \frac{Q}{2\pi \epsilon_0} \left[ \log_e \frac{\infty}{r} - \log_e \frac{\infty}{d} \right] \text{ volts} = \frac{Q}{2\pi \epsilon_0} \log_e \frac{d}{r} \text{ volts}$$

Similarly, p.d. between conductor  $B$  and neutral “infinite” plane is

$$V_B = \int_r^{\infty} \frac{-Q}{2\pi x \epsilon_0} dx + \int_d^{\infty} \frac{Q}{2\pi x \epsilon_0} dx$$

$$= \frac{-Q}{2\pi \epsilon_0} \left[ \log_e \frac{\infty}{r} - \log_e \frac{\infty}{d} \right] = \frac{-Q}{2\pi \epsilon_0} \log_e \frac{d}{r} \text{ volts}$$

Both these potentials are *w.r.t.* the same neutral plane. Since the unlike charges attract each other, the potential difference between the conductors is

$$V_{AB} = 2V_A = \frac{2Q}{2\pi \epsilon_0} \log_e \frac{d}{r} \text{ volts}$$

$$\therefore \text{Capacitance, } C_{AB} = Q/V_{AB} = \frac{Q}{\frac{2Q}{2\pi \epsilon_0} \log_e \frac{d}{r}} \text{ F/m}$$

$$\therefore C_{AB} = \frac{\pi \epsilon_0}{\log_e \frac{d}{r}} \text{ F/m} \quad \dots(i)$$

**Capacitance to neutral.** Equation (i) gives the capacitance between the conductors of a two-wire line [See Fig. 9.22]. Often it is desired to know the capacitance between one of the conductors and a neutral point between them. Since potential of the mid-point between the conductors is zero, the potential difference between each conductor and the ground or neutral is half the potential difference between the conductors. Thus the *capacitance to ground* or *capacitance to neutral* for the two-wire line is *twice* the line-to-line capacitance (capacitance between conductors as shown in Fig 9.23).

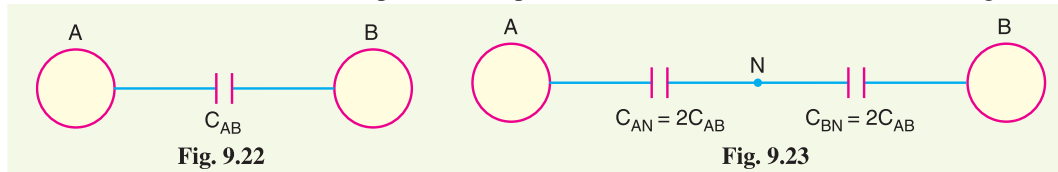

$$\therefore \text{Capacitance to neutral, } C_N = C_{AN} = C_{BN} = 2C_{AB}$$

$$\therefore C_N = \frac{2\pi \epsilon_0}{\log_e \frac{d}{r}} \text{ F/m} \quad \dots(ii)$$

The reader may compare eq. (ii) to the one for inductance. One difference between the equations for capacitance and inductance should be noted carefully. The radius in the equation for capacitance

is the actual outside radius of the conductor and not the GMR of the conductor as in the inductance formula. Note that eq. (ii) applies only to a solid round conductor.

### 9.11 Capacitance of a 3-Phase Overhead Line

In a 3-phase transmission line, the capacitance of each conductor is considered instead of capacitance from conductor to conductor. Here, again two cases arise viz., symmetrical spacing and unsymmetrical spacing.

**(i) Symmetrical Spacing.** Fig. 9.24 shows the three conductors *A*, *B* and *C* of the 3-phase overhead transmission line having charges  $Q_A$ ,  $Q_B$  and  $Q_C$  per metre length respectively. Let the conductors be equidistant (*d* metres) from each other. We shall find the capacitance from line conductor to neutral in this symmetrically spaced line. Referring to Fig. 9.24, overall potential difference between conductor *A* and infinite neutral plane is given by (Refer to Art. 9.9);

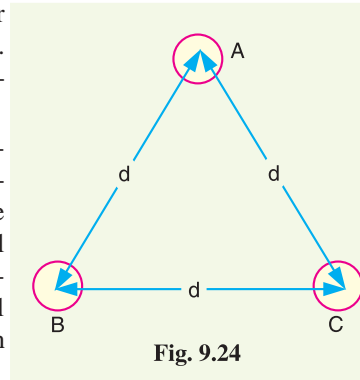

$$\begin{aligned}
 V_A &= \int_r^\infty \frac{Q_A}{2\pi x \epsilon_0} dx + \int_d^\infty \frac{Q_B}{2\pi x \epsilon_0} dx + \int_d^\infty \frac{Q_C}{2\pi x \epsilon_0} dx \\
 &= \frac{1}{2\pi \epsilon_0} \left[ Q_A \log_e \frac{1}{r} + Q_B \log_e \frac{1}{d} + Q_C \log_e \frac{1}{d} \right] \\
 &= \frac{1}{2\pi \epsilon_0} \left[ Q_A \log_e \frac{1}{r} + (Q_B + Q_C) \log_e \frac{1}{d} \right]
 \end{aligned}$$

Assuming balanced supply, we have,  $Q_A + Q_B + Q_C = 0$

$$\therefore Q_B + Q_C = -Q_A$$

$$\therefore V_A = \frac{1}{2\pi \epsilon_0} \left[ Q_A \log_e \frac{1}{r} - Q_A \log_e \frac{1}{d} \right] = \frac{Q_A}{2\pi \epsilon_0} \log_e \frac{d}{r} \text{ volts}$$

$\therefore$  Capacitance of conductor *A* w.r.t neutral,

$$C_A = \frac{Q_A}{V_A} = \frac{Q_A}{\frac{Q_A}{2\pi \epsilon_0} \log_e \frac{d}{r}} \text{ F/m} = \frac{2\pi \epsilon_0}{\log_e \frac{d}{r}} \text{ F/m}$$

$$\therefore C_A = \frac{2\pi \epsilon_0}{\log_e \frac{d}{r}} \text{ F/m}$$

Note that this equation is identical to capacitance to neutral for two-wire line. Derived in a similar manner, the expressions for capacitance are the same for conductors *B* and *C*.

**(ii) Unsymmetrical spacing.** Fig. 9.25 shows a 3-phase transposed line having unsymmetrical spacing. Let us assume balanced conditions i.e.  $Q_A + Q_B + Q_C = 0$ .

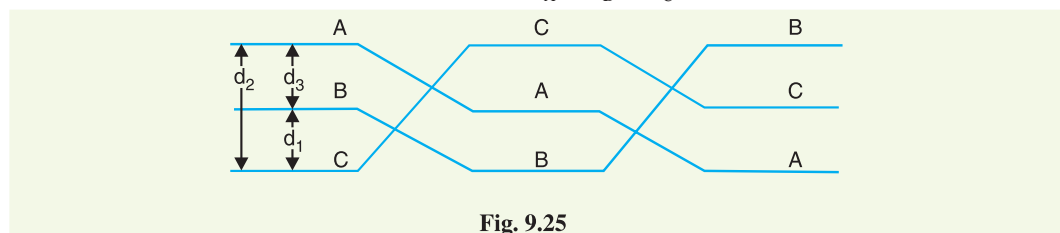

Fig. 9.25

Considering all the three sections of the transposed line for phase *A*,

$$\text{Potential of 1st position, } V_1 = \frac{1}{2\pi\epsilon_0} \left( Q_A \log_e \frac{1}{r} + Q_B \log_e \frac{1}{d_3} + Q_C \log_e \frac{1}{d_2} \right)$$

$$\text{Potential of 2nd position, } V_2 = \frac{1}{2\pi\epsilon_0} \left( Q_A \log_e \frac{1}{r} + Q_B \log_e \frac{1}{d_1} + Q_C \log_e \frac{1}{d_3} \right)$$

$$\text{Potential of 3rd position, } V_3 = \frac{1}{2\pi\epsilon_0} \left( Q_A \log_e \frac{1}{r} + Q_B \log_e \frac{1}{d_2} + Q_C \log_e \frac{1}{d_1} \right)$$

Average voltage on conductor A is

$$\begin{aligned} V_A &= \frac{1}{3} (V_1 + V_2 + V_3) \\ &= \frac{1}{3 \times 2\pi\epsilon_0} * \left[ Q_A \log_e \frac{1}{r^3} + (Q_B + Q_C) \log_e \frac{1}{d_1 d_2 d_3} \right] \end{aligned}$$

As  $Q_A + Q_B + Q_C = 0$ , therefore,  $Q_B + Q_C = -Q_A$

$$\begin{aligned} \therefore V_A &= \frac{1}{6\pi\epsilon_0} \left[ Q_A \log_e \frac{1}{r^3} - Q_A \log_e \frac{1}{d_1 d_2 d_3} \right] \\ &= \frac{Q_A}{6\pi\epsilon_0} \log_e \frac{d_1 d_2 d_3}{r^3} \\ &= \frac{1}{3} \times \frac{Q_A}{2\pi\epsilon_0} \log_e \frac{d_1 d_2 d_3}{r^3} \\ &= \frac{Q_A}{2\pi\epsilon_0} \log_e \left( \frac{d_1 d_2 d_3}{r^3} \right)^{1/3} \\ &= \frac{Q_A}{2\pi\epsilon_0} \log_e \frac{(d_1 d_2 d_3)^{1/3}}{r} \end{aligned}$$

$\therefore$  Capacitance from conductor to neutral is

$$C_A = \frac{Q_A}{V_A} = \frac{2\pi\epsilon_0}{\log_e \frac{\sqrt[3]{d_1 d_2 d_3}}{r}} \text{ F/m}$$



Capacitance Measurement using bridge

**Example 9.11** A single-phase transmission line has two parallel conductors 3 metres apart, radius of each conductor being 1 cm. Calculate the capacitance of the line per km. Given that  $\epsilon_0 = 8.854 \times 10^{-12}$  F/m.

**Solution.**

Conductor radius,  $r = 1$  cm

Spacing of conductors,  $d = 3$  m = 300 cm

$$\begin{aligned} \text{Capacitance of the line} &= \frac{\pi\epsilon_0}{\log_e d/r} \text{ F/m} = \frac{\pi \times 8.854 \times 10^{-12}}{\log_e 300/1} \text{ F/m} \\ &= 0.4875 \times 10^{-11} \text{ F/m} = 0.4875 \times 10^{-8} \text{ F/km} \\ &= \mathbf{0.4875 \times 10^{-2} \mu\text{F/km}} \end{aligned}$$

\* On solving

**Example 9.12.** A 3-phase overhead transmission line has its conductors arranged at the corners of an equilateral triangle of 2 m side. Calculate the capacitance of each line conductor per km. Given that diameter of each conductor is 1.25 cm.

**Solution.**

Conductor radius,  $r = 1.25/2 = 0.625$  cm

Spacing of conductors,  $d = 2$  m = 200 cm

Capacitance of each line conductor

$$\begin{aligned} &= \frac{2\pi\epsilon_0}{\log_e d/r} \text{ F/m} = \frac{2\pi \times 8.854 \times 10^{-12}}{\log_e 200/0.625} \text{ F/m} \\ &= 0.0096 \times 10^{-9} \text{ F/m} = 0.0096 \times 10^{-6} \text{ F/km} = \mathbf{0.0096 \mu\text{F/km}} \end{aligned}$$

**Example 9.13.** A 3-phase, 50 Hz, 66 kV overhead line conductors are placed in a horizontal plane as shown in Fig. 9.26. The conductor diameter is 1.25 cm. If the line length is 100 km, calculate (i) capacitance per phase, (ii) charging current per phase, assuming complete transposition of the line.

**Solution.** Fig 9.26 shows the arrangement of conductors of the 3-phase line. The equivalent equilateral spacing is

$$d = \sqrt[3]{d_1 d_2 d_3} = \sqrt[3]{2 \times 2.5 \times 4.5} = 2.82 \text{ m}$$

Conductor radius,  $r = 1.25/2 = 0.625$  cm

Conductor spacing,  $d = 2.82$  m = 282 cm

$$\begin{aligned} \text{(i) Line to neutral capacitance} &= \frac{2\pi\epsilon_0}{\log_e d/r} \text{ F/m} = \frac{2\pi \times 8.854 \times 10^{-12}}{\log_e 282/0.625} \text{ F/m} \\ &= 0.0091 \times 10^{-9} \text{ F/m} = 0.0091 \times 10^{-6} \text{ F/km} = \mathbf{0.0091 \mu\text{F/km}} \end{aligned}$$

$\therefore$  Line to neutral capacitance for 100 km line is

$$C = 0.0091 \times 100 = \mathbf{0.91 \mu\text{F}}$$

**(ii)** Charging current per phase is

$$\begin{aligned} I_C &= \frac{V_{ph}}{X_C} = \frac{66,000}{\sqrt{3}} \times 2\pi f C \\ &= \frac{66,000}{\sqrt{3}} \times 2\pi \times 50 \times 0.91 \times 10^{-6} = \mathbf{10.9 \text{ A}} \end{aligned}$$

**Example 9.14.** Calculate the capacitance of a 100 km long 3-phase, 50 Hz overhead transmission line consisting of 3 conductors, each of diameter 2 cm and spaced 2.5 m at the corners of an equilateral triangle.

**Solution.**

Equilateral spacing,  $d = 2.5$  m = 250 cm

Radius of conductor,  $r = 2/2 = 1$  cm

Capacitance of each conductor to neutral

$$\begin{aligned} &= \frac{2\pi\epsilon_0}{\log_e d/r} \text{ F/m} = \frac{2\pi \times 8.85 \times 10^{-12}}{\log_e 250/1} \text{ F/m} \\ &= 10.075 \times 10^{-12} \text{ F/m} = 10.075 \times 10^{-9} \text{ F/km} \end{aligned}$$

$\therefore$  Capacitance of 100 km line =  $(10.075 \times 10^{-9}) \times 100 = 1.0075 \times 10^{-6} \text{ F} = \mathbf{1.0075 \mu\text{F/phase}}$

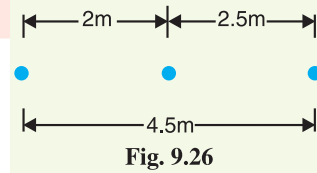



**Example 9.15.** A 3-phase, 50 Hz, 132 kV overhead line has conductors placed in a horizontal plane 4 m apart. Conductor diameter is 2 cm. If the line length is 100 km, calculate the charging current per phase assuming complete transposition.

**Solution.** Fig 9.27 shows the conditions of the problem. The diameter of each conductor is 2 cm so that conductor radius  $r = 2/2 = 1 \text{ cm} = 1 \times 10^{-2} \text{ m}$ .

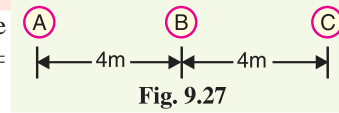

Now  $d_1 = AB = 4 \text{ m}$ ;  $d_2 = BC = 4 \text{ m}$ ;  $d_3 = AC = 8 \text{ m}$

$$\therefore D_{eq} = \sqrt[3]{d_1 \times d_2 \times d_3} = \sqrt[3]{4 \times 4 \times 8} = 5.04 \text{ m}$$

Capacitance of each conductor to neutral

$$\begin{aligned} &= \frac{2 \pi \epsilon_0}{\log_e D_{eq}/r} \text{ F/m} = \frac{2 \pi \times 8.85 \times 10^{-12}}{\log_e 5.04/1 \times 10^{-2}} \text{ F/m} \\ &= 0.00885 \times 10^{-6} \text{ F/km} \end{aligned}$$

Capacitance/phase for 100 km line is

$$C_n = 0.00885 \times 10^{-6} \times 100 = 0.885 \times 10^{-6} \text{ F}$$

$$\text{Phase voltage, } V_{ph} = \frac{\text{Line Voltage}}{\sqrt{3}} = \frac{132 \times 10^3}{\sqrt{3}} = 76210 \text{ V}$$

$$\therefore \text{Charging current/phase, } I_C = \omega C_n V_{ph} = (2 \pi \times 50) \times (0.885 \times 10^{-6}) \times 76210 = \mathbf{21.18 \text{ A}}$$

### TUTORIAL PROBLEMS

1. A single phase transmission line has two parallel conductors 1.5 metres apart, the diameter of each conductor being 0.5 cm. Calculate line to neutral capacitance for a line 80 km long. [3.48  $\mu\text{F}$ ]
2. A 200 km, 3-phase transmission line has its conductors placed at the corners of an equilateral triangle of 2.5 m side. The radius of each conductor is 1 cm. Calculate :
  - (i) line to neutral capacitance of the line,
  - (ii) charging current per phase if the line is maintained at 66 kV, 50 Hz. [(i) 2.02  $\mu\text{F}$  (ii) 24.2 A]
3. The three conductors A, B and C of a 3- $\phi$  line are arranged in a horizontal plane with  $D_{AB} = 2 \text{ m}$  and  $D_{BC} = 2.5 \text{ m}$ . Find line-to-neutral capacitance per km if diameter of each conductor is 1.24 cm. The conductors are transposed at regular intervals. [0.0091  $\mu\text{F/km}$ ]
4. The three conductors of a 3- $\phi$  line are arranged at the corners of a right angled isosceles triangle. If each equal side of this triangle is 2 m, find line-to-neutral capacitance per km. Take the diameter of each conductor as 1.24 cm. The conductors are transposed at regular intervals. [0.0094  $\mu\text{F/km}$ ]
5. A 3-phase, 50 Hz, 132 kV overhead line has conductors placed in a horizontal plane 4.56 m apart. Conductor diameter is 22.4 mm. If the line length is 100 km, Calculate the charging current per phase, assuming complete transposition. [21.345 A]
6. Three conductors of a 3-phase overhead line are arranged in a horizontal plane 6 m apart. The diameter of each conductor is 1.24 cm. Find the capacitance of each conductor to neutral per 100 km of the line. [0.785  $\mu\text{F}$ ]

### SELF - TEST

1. Fill in the blanks by inserting appropriate words/figures.
  - (i) The power loss in an overhead transmission line is mainly due to .....
  - (ii) If the length of a transmission line increases, its inductance is .....
  - (iii) The d.c. resistance of a line conductor is ..... than its a.c. resistance.
  - (iv) If capacitance between two conductors of a 3-phase line is 4  $\mu\text{F}$ , then capacitance of each conductor to neutral is .....

- (v) If the length of the line is decreased, its capacitance is .....
- (vi) Transposition of a 3-phase transmission line helps in .....
- (vii) A neutral plane is one where ..... is zero.
- (viii) In a single phase overhead line, the neutral plane lies at .....
2. Pick up the correct words/figures from brackets and fill in the blanks
- (i) If the supply frequency increases, then skin effect is ..... [increases, decreased]
- (ii) An overhead transmission line has appreciable inductance because the loop it forms has ..... X-sectional area. [large, small]
- (iii) If the spacing between the conductors is increased, the inductance of the line..... [increases, decreases]
- (iv) The skin effect is ..... for stranded conductor than the solid conductor. [less, more]
- (v) If the conductor diameter decreases, inductance of the line is ..... [increased, decreased]

### ANSWERS TO SELF-TEST

1. (i) Line conductor resistance (ii) increased (iii) less (iv)  $8 \mu\text{F}$  (v) decreased (vi) equalising inductance and capacitance of the three phases (vii) electric intensity (viii) the centre of the distance between the conductors
2. (i) increased (ii) large (iii) increases (iv) less (v) increased

### CHAPTER REVIEW TOPICS

- What do you understand by the constants of an overhead transmission line ?
- What is skin effect ? Why is it absent in the d.c. system ?
- Find an expression for the flux linkages
  - due to a single current carrying conductor
  - in parallel current carrying conductors
- Derive an expression for the loop inductance of a single phase line.
- Derive an expression for the inductance per phase for a 3-phase overhead transmission line when
  - conductors are symmetrically placed
  - conductors are unsymmetrically placed but the line is completely transposed
- What do you understand by electric potential ? Derive an expression for electric potential
  - at a charged single conductor
  - at a conductor in a group of charged conductors
- Derive an expression for the capacitance of a single phase overhead transmission line.
- Deduce an expression for line to neutral capacitance for a 3-phase overhead transmission line when the conductors are
  - symmetrically placed
  - unsymmetrically placed but transposed

### DISCUSSION QUESTIONS

- What is the effect of unsymmetrical spacing of conductors in a 3-phase transmission line ?
- Will capacitance of a transmission line depend upon the ground effect ?
- Why do we find line to neutral capacitance in a 3-phase system ?
- How does skin effect vary with conductor material ?
- What is proximity effect ?