

## CHAPTER

# 21



## Protective Relays

- 21.1 Protective Relays
- 21.2 Fundamental Requirements of Protective Relaying
- 21.3 Basic Relays
- 21.4 Electromagnetic Attraction Relays
- 21.5 Induction Relays
- 21.6 Relay Timing
- 21.7 Important Terms
- 21.8 Time/P.S.M. Curve
- 21.9 Calculation of Relay Operating Time
- 21.10 Functional Relay Types
- 21.11 Induction Type Overcurrent Relay (non-directional)
- 21.12 Induction Type Directional Power Relay
- 21.13 Induction Type Directional Overcurrent Relay
- 21.14 Distance or Impedance Relays
- 21.15 Definite – Distance Type Impedance Relay
- 21.16 Time – Distance Impedance Relay
- 21.17 Differential Relays
- 21.18 Current Differential Relay
- 21.19 Voltage Balance Differential Relay
- 21.20 Translay System
- 21.21 Types of Protection

### Introduction

In a power system consisting of generators, transformers, transmission and distribution circuits, it is inevitable that sooner or later some failure will occur somewhere in the system. When a failure occurs on any part of the system, it must be quickly detected and disconnected from the system. There are two principal reasons for it. Firstly, if the fault is not cleared quickly, it may cause unnecessary interruption of service to the customers. Secondly, rapid disconnection of faulted apparatus limits the amount of damage to it and prevents the effects of fault from spreading into the system.

The detection of a fault and disconnection of a faulty section or apparatus can be achieved by using *fuses* or *relays in conjunction with circuit breakers*. A fuse performs both detection and interruption functions automatically but its use is limited for the protection of low-voltage circuits only. For high voltage circuits (say above 3.3 kV), relays and circuit breakers are employed to serve the desired function of automatic protective gear. The relays detect the fault and supply information to the circuit breaker which performs the function of circuit interruption. In this

chapter, we shall focus our attention on the various types of relays and their increasing use for the protection of power system.

### 21.1 Protective Relays

A **protective relay** is a device that detects the fault and initiates the operation of the circuit breaker to isolate the defective element from the rest of the system.

The relays detect the abnormal conditions in the electrical circuits by constantly measuring the electrical quantities which are different under normal and fault conditions. The electrical quantities which may change under fault conditions are voltage, current, frequency and phase angle. Through the changes in one or more of these quantities, the faults signal their presence, type and location to the protective relays. Having detected the fault, the relay operates to close the trip circuit of the breaker. This results in the opening of the breaker and disconnection of the faulty circuit.

A typical relay circuit is shown in Fig. 21.1. This diagram shows one phase of 3-phase system for simplicity. The relay circuit connections can be divided into three parts *viz.*

- (i) First part is the primary winding of a current transformer (C.T.) which is connected in series with the line to be protected.
- (ii) Second part consists of secondary winding of C.T. and the relay operating coil.
- (iii) Third part is the tripping circuit which may be either a.c. or d.c. It consists of a source of supply, the trip coil of the circuit breaker and the relay stationary contacts.

When a short circuit occurs at point *F* on the transmission line, the current flowing in the line increases to an enormous value. This results in a heavy current flow through the relay coil, causing the relay to operate by closing its contacts. This in turn closes the trip circuit of the breaker, making the circuit breaker open and isolating the faulty section from the rest of the system. In this way, the relay ensures the safety of the circuit equipment from damage and normal working of the healthy portion of the system.

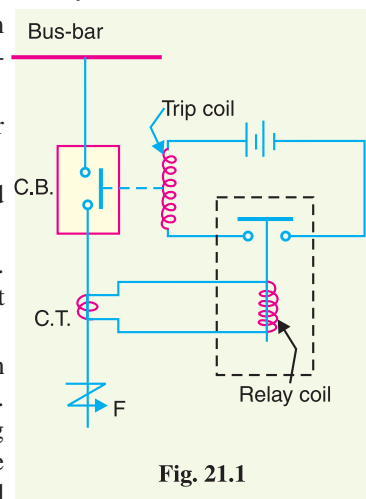

Fig. 21.1

### 21.2 Fundamental Requirements of Protective Relaying

The principal function of protective relaying is to cause the prompt removal from service of any element of the power system when it starts to operate in an abnormal manner or interfere with the effective operation of the rest of the system. In order that protective relay system may perform this function satisfactorily, it should have the following qualities :

- (i) selectivity
- (ii) speed
- (iii) sensitivity
- (iv) reliability
- (v) simplicity
- (vi) economy

(i) **Selectivity.** It is the ability of the protective system to select correctly that part of the system in trouble and disconnect the faulty part without disturbing the rest of the system.

A well designed and efficient relay system should be selective *i.e.* it should be able to detect the point at which the fault occurs and cause the opening of the circuit breakers closest to the fault with minimum or no damage to the system. This can be illustrated by referring to the single line diagram of a portion of a typical power system shown in Fig. 21.2. It may be seen that circuit breakers are located in the connections to each power system element in order to make it possible to disconnect only the faulty section. Thus, if a fault occurs at bus-bars on the last zone, then only breakers nearest to the fault *viz.* 10, 11, 12 and 13 should open. In fact, opening of any other breaker to clear the fault will lead to a greater part of the system being disconnected.

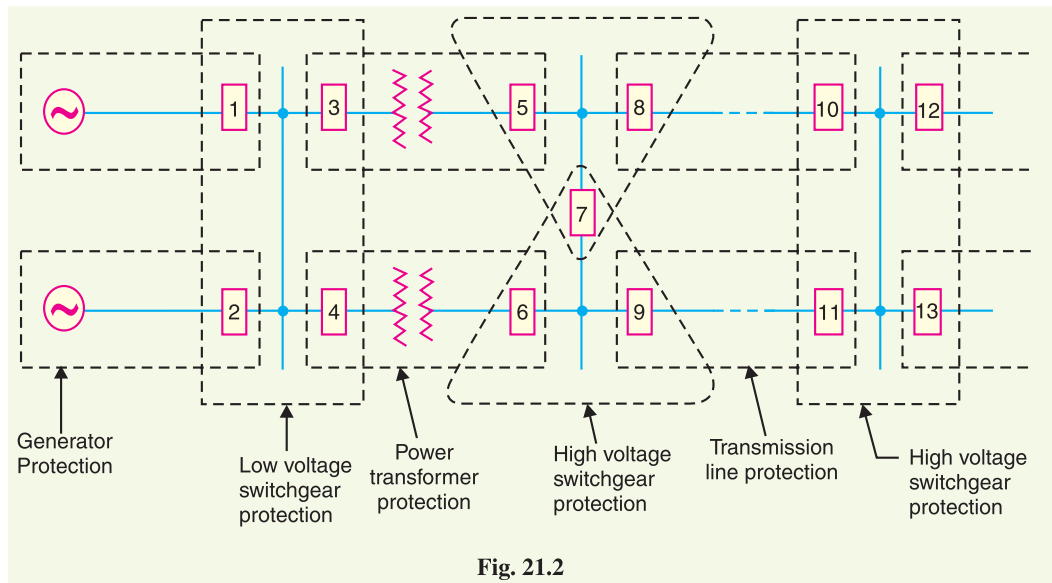

In order to provide selectivity to the system, it is a usual practice to divide the entire system into several protection zones. When a fault occurs in a given zone, then only the circuit breakers within that zone will be opened. This will isolate only the faulty circuit or apparatus, leaving the healthy circuits intact. The system can be divided into the following protection zones :

- |                             |                            |                  |
|-----------------------------|----------------------------|------------------|
| (a) generators              | (b) low-tension switchgear | (c) transformers |
| (d) high-tension switchgear | (e) transmission lines     |                  |

It may be seen in Fig. 21.2 that there is certain amount of overlap between the adjacent protection zones. For a failure within the region where two adjacent zones overlap, more breakers will be opened than the minimum necessary to disconnect the faulty section. But if there were no overlap, a failure in the region between zones would not lie in either region and, therefore, no breaker would be opened. For this reason, a certain amount of overlap\* is provided between the adjacent zones.

**(ii) Speed.** The relay system should disconnect the faulty section as fast as possible for the following reasons :

- (a) Electrical apparatus may be damaged if they are made to carry the fault currents for a long time.
- (b) A failure on the system leads to a great reduction in the system voltage. If the faulty section is not disconnected quickly, then the low voltage created by the fault may shut down consumers' motors and the generators on the system may become unstable.
- (c) The high speed relay system decreases the possibility of development of one type of fault into the other more severe type.

**(iii) Sensitivity.** *It is the ability of the relay system to operate with low value of actuating quantity.*

Sensitivity of a relay is a function of the volt-amperes input to the coil of the relay necessary to cause its operation. The smaller the volt-ampere input required to cause relay operation, the more sensitive is the relay. Thus, a 1 VA relay is more sensitive than a 3 VA relay. It is desirable that relay system should be sensitive so that it operates with low values of volt-ampere input.

\* The overlap is usually small and the probability of failure in this region is low. Therefore, opening of too many breakers will be quite infrequent.

(iv) **Reliability.** It is the ability of the relay system to operate under the pre-determined conditions. Without reliability, the protection would be rendered largely ineffective and could even become a liability.

(v) **Simplicity.** The relaying system should be simple so that it can be easily maintained. Reliability is closely related to simplicity. The simpler the protection scheme, the greater will be its reliability.

(vi) **Economy.** The most important factor in the choice of a particular protection scheme is the economic aspect. Sometimes it is economically unjustified to use an ideal scheme of protection and a compromise method has to be adopted. As a rule, the protective gear should not cost more than 5% of total cost. However, when the apparatus to be protected is of utmost importance (e.g. generator, main transmission line etc.), economic considerations are often subordinated to reliability.

### 21.3 Basic Relays

Most of the relays used in the power system operate by virtue of the current and/or voltage supplied by current and voltage transformers connected in various combinations to the system element that is to be protected. Through the individual or relative changes in these two quantities, faults signal their presence, type and location to the protective relays. Having detected the fault, the relay operates the trip circuit which results in the opening of the circuit breaker and hence in the disconnection of the faulty circuit.

Most of the relays in service on electric power system today are of electro-mechanical type. They work on the following two main operating principles :

- (i) Electromagnetic attraction
- (ii) Electromagnetic induction

### 21.4 Electromagnetic Attraction Relays

Electromagnetic attraction relays operate by virtue of an armature being attracted to the poles of an electromagnet or a plunger being drawn into a solenoid. Such relays may be actuated by d.c. or a.c. quantities. The important types of electromagnetic attraction relays are :

(i) **Attracted armature type relay.** Fig. 21.3 shows the schematic arrangement of an attracted armature type relay. It consists of a laminated electromagnet  $M$  carrying a coil  $C$  and a pivoted laminated armature. The armature is balanced by a counterweight and carries a pair of spring contact fingers at its free end. Under normal operating conditions, the current through the relay coil  $C$  is such that counterweight holds the armature in the position shown. However, when a short-circuit occurs, the current through the relay coil increases sufficiently and the relay armature is attracted upwards. The contacts on the relay armature bridge a pair of stationary contacts attached to the relay frame. This completes the trip circuit which results in the opening of the circuit breaker and, therefore, in the disconnection of the faulty circuit.

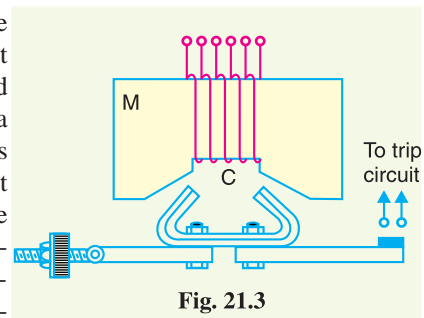

Fig. 21.3

The minimum current at which the relay armature is attracted to close the trip circuit is called **pickup current**. It is a usual practice to provide a number of tappings on the relay coil so that the number of turns in use and hence the setting value at which the relay operates can be varied.

(ii) **Solenoid type relay.** Fig. 21.4 shows the schematic arrangement of a solenoid type relay. It consists of a solenoid and movable iron plunger arranged as shown. Under normal operating conditions, the current through the relay coil  $C$  is such that it holds the plunger by gravity or spring in the position shown. However, on the occurrence of a fault, the current through the relay coil becomes

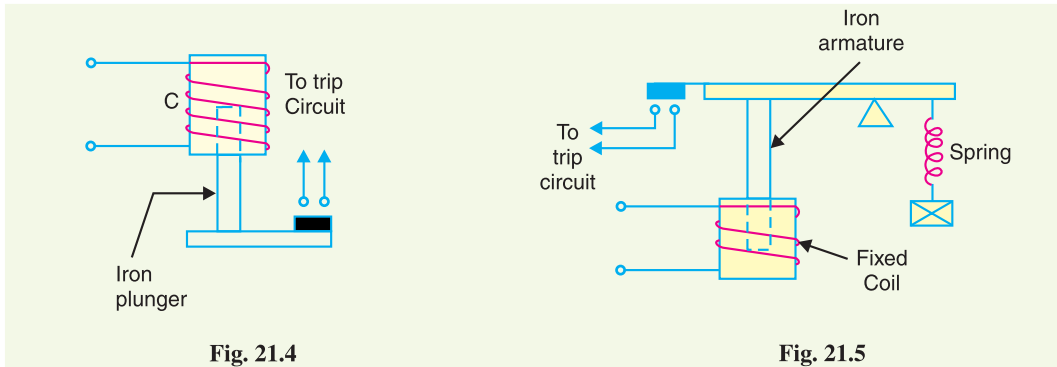

Fig. 21.4

Fig. 21.5

more than the pickup value, causing the plunger to be attracted to the solenoid. The upward movement of the plunger closes the trip circuit, thus opening the circuit breaker and disconnecting the faulty circuit.

(iii) **Balanced beam type relay.** Fig. 21.5 shows the schematic arrangement of a balanced beam type relay. It consists of an iron armature fastened to a balance beam. Under normal operating conditions, the current through the relay coil is such that the beam is held in the horizontal position by the spring. However, when a fault occurs, the current through the relay coil becomes greater than the pickup value and the beam is attracted to close the trip circuit. This causes the opening of the circuit breaker to isolate the faulty circuit.



Electromagnetic relay

## 21.5 Induction Relays

Electromagnetic induction relays operate on the principle of induction motor and are widely used for protective relaying purposes involving a.c. quantities. They are not used with d.c. quantities owing to the principle of operation. An induction relay essentially consists of a pivoted aluminium disc placed in two alternating magnetic fields of the same frequency but displaced in time and space. The torque is produced in the disc by the interaction of one of the magnetic fields with the currents induced in the disc by the other.

To understand the production of torque in an induction relay, refer to the elementary arrangement shown in Fig. 21.6 (i). The two a.c. fluxes  $\phi_2$  and  $\phi_1$  differing in phase by an angle  $\alpha$  induce e.m.f.s' in the disc and cause the circulation of eddy currents  $i_2$  and  $i_1$  respectively. These currents lag behind their respective fluxes by  $90^\circ$ .

Referring to Fig. 21.6 (ii) where the two a.c. fluxes and induced currents are shown separately for clarity, let

$$\phi_1 = \phi_{1max} \sin \omega t$$

$$\phi_2 = \phi_{2max} \sin (\omega t + \alpha)$$

where  $\phi_1$  and  $\phi_2$  are the instantaneous values of fluxes and  $\phi_2$  leads  $\phi_1$  by an angle  $\alpha$ .

Assuming that the paths in which the rotor currents flow have negligible self-inductance, the rotor currents will be in phase with their voltages.

$$\therefore i_1 \propto \frac{d\phi_1}{dt} \propto \frac{d}{dt} (\phi_{1max} \sin \omega t)$$

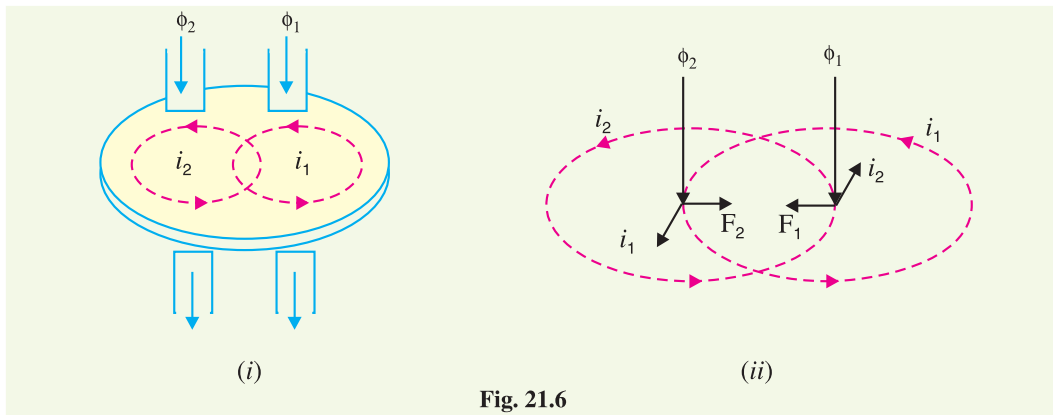

Fig. 21.6

$$\propto \phi_{1max} \cos \omega t$$

$$\text{and } i_2 \propto \frac{d\phi_2}{dt} \propto \phi_{2max} \cos(\omega t + \alpha)$$

$$\text{Now, } F_1 \propto \phi_1 i_2 \text{ and } F_2 \propto \phi_2 i_1$$

Fig. 21.6 (ii) shows that the two forces are in opposition.

$\therefore$  Net force  $F$  at the instant considered is

$$\begin{aligned} F &\propto F_2 - F_1 \\ &\propto \phi_2 i_1 - \phi_1 i_2 \\ &\propto \phi_{2max} \sin(\omega t + \alpha) \phi_{1max} \cos \omega t - \phi_{1max} \sin \omega t \phi_{2max} \cos(\omega t + \alpha) \\ &\propto \phi_{1max} \phi_{2max} [\sin(\omega t + \alpha) \cos \omega t - \sin \omega t \cos(\omega t + \alpha)] \\ &\propto \phi_{1max} \phi_{2max} \sin \alpha \\ &\propto \phi_1 \phi_2 \sin \alpha \quad \dots(i) \end{aligned}$$

where  $\phi_1$  and  $\phi_2$  are the r.m.s. values of the fluxes.

The following points may be noted from exp. (i) :

- (a) The greater the phase angle  $\alpha$  between the fluxes, the greater is the net force applied to the disc. Obviously, the maximum force will be produced when the two fluxes are  $90^\circ$  out of phase.
- (b) The net force is the same at every instant. This fact does not depend upon the assumptions made in arriving at exp. (i).
- (c) The direction of net force and hence the direction of motion of the disc depends upon which flux is leading.

The following three types of structures are commonly used for obtaining the phase difference in the fluxes and hence the operating torque in induction relays :

- (i) shaded-pole structure
- (ii) watt-hour-meter or double winding structure
- (iii) induction cup structure

(i) **Shaded-pole structure.** The general arrangement of shaded-pole structure is shown in Fig. 21.7. It consists of a pivoted aluminium disc free to rotate in the air-gap of an electromagnet. One-half of each pole of the magnet is surrounded by a copper band known as *shading ring*. The alternating flux  $\phi_s$  in the shaded portion of the poles will, owing to the reaction of the current induced in the ring, lag behind the flux  $\phi_u$  in the unshaded portion by an angle  $\alpha$ . These two a.c. fluxes differing in phase will produce the necessary torque to rotate the disc. As proved earlier, the driving torque  $T$  is

given by;

$$T \propto \phi_s \phi_u \sin \alpha$$

Assuming the fluxes  $\phi_s$  and  $\phi_u$  to be proportional to the current  $I$  in the relay coil,

$$T \propto I^2 \sin \alpha$$

This shows that driving torque is proportional to the square of current in the relay coil.

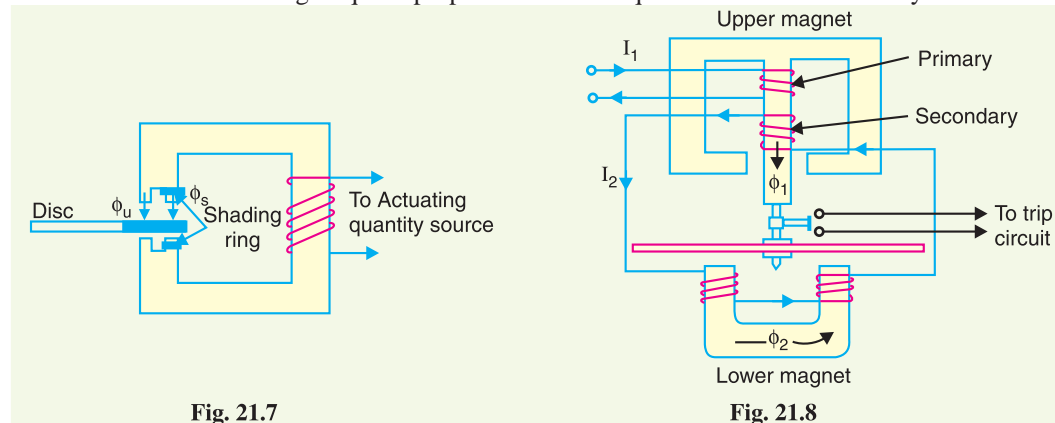

**(ii) Watthour-meter structure.** This structure gets its name from the fact that it is used in watt-hour meters. The general arrangement of this type of relay is shown in Fig. 21.8. It consists of a pivoted aluminium disc arranged to rotate freely between the poles of two electromagnets. The upper electromagnet carries two windings ; the pimary and the secondary. The primary winding carries the relay current  $I_1$  while the secondary winding is connected to the winding of the lower magnet. The primary current  $I_1$  induces e.m.f. in the secondary and so circulates a current  $I_2$  in it. The flux  $\phi_2$  induced in the lower magnet by the current in the secondary winding of the upper magnet will lag behind  $\phi_1$  by an angle  $\alpha$ . The two fluxes  $\phi_1$  and  $\phi_2$  differing in phase by  $\alpha$  will produce a driving torque on the disc proportional to  $\phi_1 \phi_2 \sin \alpha$ .

An important feature of this type of relay is that its operation can be controlled by opening or closing the secondary winding circuit. If this circuit is opened, no flux can be set by the lower magnet however great the vaule of current in the pimary winding may be and consequently no torque will be produced. Therefore, the relay can be made inoperative by opening its secondary winding circuit.

**(iii) Induction cup structure.** Fig. 21.9 shows the general arrangement of an induction cup structure. It most closely resembles an induction motor, except that the rotor iron is stationary, only the rotor conductor portion being free to rotate.

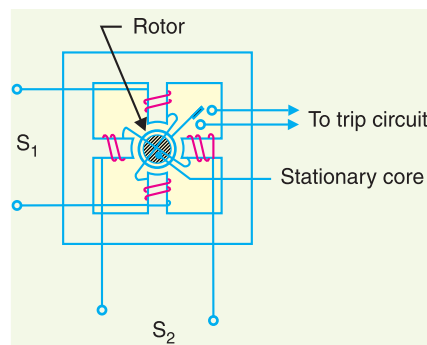

Fig. 21.9

The moving element is a hollow cylindrical rotor which turns on its axis. The rotating field is produced by two pairs of coils wound on four poles as shown. The rotating field induces currents in the cup to provide the necessary driving torque.

If  $\phi_1$  and  $\phi_2$  represent the fluxes produced by the respective pairs of poles, then torque produced is proportional to  $\phi_1 \phi_2 \sin \alpha$  where  $\alpha$  is the phase



Induction relay

difference between the two fluxes. A control spring and the back stop for closing of the contacts carried on an arm are attached to the spindle of the cup to prevent the continuous rotation.

Induction cup structures are more efficient torque producers than either the shaded-pole or the watt-hour meter structures. Therefore, this type of relay has very high speed and may have an operating time less than 0.1 second.

## 21.6 Relay Timing

An important characteristic of a relay is its time of operation. By 'the time of operation' is meant length of the time from the instant when the actuating element is energised to the instant when the relay contacts are closed. Sometimes it is desirable and necessary to control the operating time of a relay. For this purpose, mechanical accessories are used with relays.

(i) **Instantaneous relay.** An instantaneous relay is one in which no intentional time delay is provided. In this case, the relay contacts are closed immediately after current in the relay coil exceeds the minimum calibrated value. Fig. 21.10 shows an instantaneous solenoid type of relay. Although there will be a short time interval between the instant of pickup and the closing of relay contacts, no intentional time delay has been added. The instantaneous relays have operating time less than 0.1 second. The instantaneous relay is effective only where the impedance between the relay and source is small compared to the protected section impedance. The operating time of instantaneous relay is sometimes expressed in cycles based on the power-system frequency *e.g.* one-cycle would be 1/50 second in a 50-cycle system.

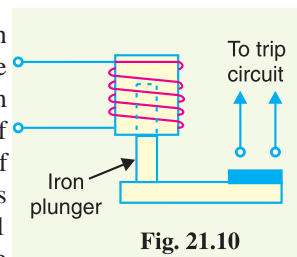

Fig. 21.10

(ii) **Inverse-time relay.** An inverse-time relay is one in which the operating time is approximately inversely proportional to the magnitude of the actuating quantity. Fig. 21.11 shows the time-current characteristics of an inverse current relay. At values of current less than pickup, the relay never operates. At higher values, the time of operation of the relay decreases steadily with the increase of current. The inverse-time delay can be achieved by associating mechanical accessories with relays.

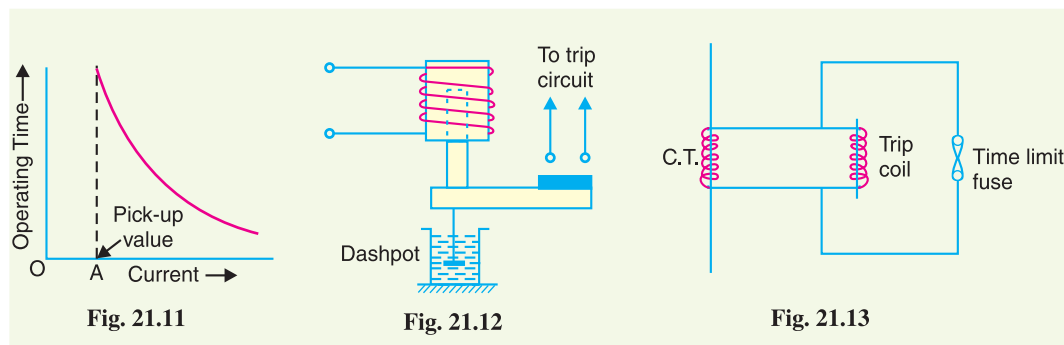

Fig. 21.11

Fig. 21.12

Fig. 21.13

- (a) In an induction relay, the inverse-time delay can be achieved by positioning a permanent magnet (known as a *drag magnet*) in such a way that relay disc cuts the flux between the poles of the magnet. When the disc moves, currents set up in it produce a drag on the disc which slows its motion.
- (b) In other types of relays, the inverse time delay can be introduced by oil dashpot or a time-limit fuse. Fig. 21.12 shows an inverse time solenoid relay using oil dashpot. The piston in the oil dashpot attached to the moving plunger slows its upward motion. At a current value just equal to the pickup, the plunger moves slowly and time delay is at a maximum. At higher values of relay current, the delay time is shortened due to greater pull on the plunger.



The inverse-time characteristic can also be obtained by connecting a time-limit fuse in parallel with the trip coil terminals as shown in Fig. 21.13. The shunt path formed by time-limit fuse is of negligible impedance as compared with the relatively high impedance of the trip coil. Therefore, so long as the fuse remains intact, it will divert practically the whole secondary current of CT from the trip coil. When the secondary current exceeds the current carrying capacity of the fuse, the fuse will blow and the whole current will pass through the trip coil, thus opening the circuit breaker. The time-lag between the incidence of excess current and the tripping of the breaker is governed by the characteristics of the fuse. Careful selection of the fuse can give the desired inverse-time characteristics, although necessity for replacement after operation is a disadvantage.

**(iii) Definite time lag relay.** In this type of relay, there is a definite time elapse between the instant of pickup and the closing of relay contacts. This particular time setting is independent of the amount of current through the relay coil; being the same for all values of current in excess of the pickup value. It may be worthwhile to mention here that practically all inverse-time relays are also provided with definite minimum time feature in order that the relay may never become instantaneous in its action for very long overloads.

## 21.7 Important Terms

It is desirable to define and explain some important terms much used in connection with relays.

**(i) Pick-up current.** It is the minimum current in the relay coil at which the relay starts to operate. So long as the current in the relay is less than the pick-up value, the relay does not operate and the breaker controlled by it remains in the closed position. However, when the relay coil current is equal to or greater than the pickup value, the relay operates to energise the trip coil which opens the circuit breaker.

**(ii) Current setting.** It is often desirable to adjust the pick-up current to any required value. This is known as current setting and is usually achieved by the use of tapings on the relay operating coil. The taps are brought out to a plug bridge as shown in Fig. 21.14. The plug bridge permits to alter the number of turns on the relay coil. This changes the torque on the disc and hence the time of operation of the relay. The values assigned to each tap are expressed in terms of percentage full-load rating of C.T. with which the relay is associated and represents the value *above* which the disc commences to rotate and finally closes the trip circuit.

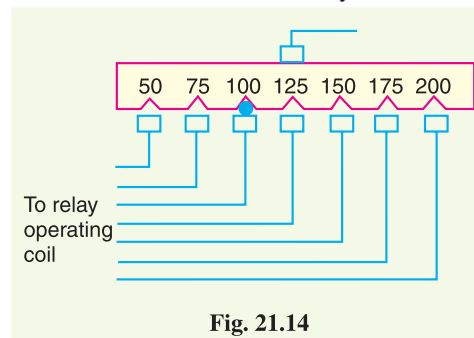

Fig. 21.14

$$\therefore \text{Pick-up current} = \text{Rated secondary current of C.T.} \times \text{Current setting}$$

For example, suppose that an overcurrent relay having current setting of 125% is connected to a supply circuit through a current transformer of 400/5. The rated secondary current of C.T. is 5 amperes. Therefore, the pick-up value will be 25% more than 5 A *i.e.*  $5 \times 1.25 = 6.25$  A. It means that with above current setting, the relay will actually operate for a relay coil current equal to or greater than 6.25 A.

The current plug settings usually range from 50% to 200% in steps of 25% for overcurrent relays and 10% to 70% in steps of 10% for earth leakage relays. The desired current setting is obtained by inserting a plug between the jaws of a bridge type socket at the tap value required.

**(iii) Plug-setting multiplier (P.S.M.).** It is the ratio of fault current in relay coil to the pick-up current *i.e.*

$$\text{P.S.M.} = \frac{\text{Fault current in relay coil}}{\text{Pick-up current}}$$

$$= \frac{\text{Fault current in relay coil}}{\text{Rated secondary current of CT} \times \text{Current setting}}$$

For example, suppose that a relay is connected to a 400/5 current transformer and set at 150%. With a primary fault current of 2400 A, the plug-setting multiplier can be calculated as under :

$$\begin{aligned} \text{Pick-up value} &= \text{Rated secondary current of CT} \times \text{Current setting} \\ &= 5 \times 1.5 = 7.5 \text{ A} \end{aligned}$$

$$\text{Fault current in relay coil} = 2400 \times \frac{5}{400} = 30 \text{ A}$$

$$\therefore \text{P.S.M.} = 30/7.5 = 4$$

**(iv) Time-setting multiplier.** A relay is generally provided with control to adjust the time of operation. This adjustment is known as time-setting multiplier. The time-setting dial is calibrated from 0 to 1 in steps of 0.05 sec (see Fig. 21.15). These figures are multipliers to be used to convert the time derived from time/P.S.M. curve into the actual operating time. Thus if the time setting is 0.1 and the time obtained from the time/P.S.M. curve is 3 seconds, then actual relay operating time =  $3 \times 0.1 = 0.3$  second. For instance, in an induction relay, the time of operation is controlled by adjusting the amount of travel of the disc from its reset position to its pickup position. This is achieved by the adjustment of the position of a movable backstop which controls the travel of the disc and thereby varies the time in which the relay will close its contacts for given values of fault current. A so-called “time dial” with an evenly divided scale provides this adjustment. The actual time of operation is calculated by multiplying the time setting multiplier with the time obtained from time/P.S.M. curve of the relay.

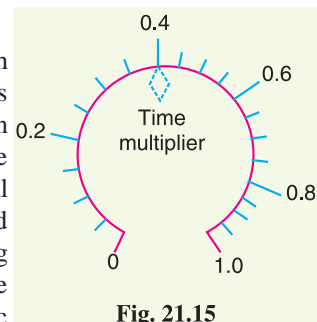

Fig. 21.15

## 21.8 Time/P.S.M. Curve

Fig. 21.16 shows the curve between time of operation and plug setting multiplier of a typical relay. The horizontal scale is marked in terms of plug-setting multiplier and represents the number of times the relay current is in excess of the current setting. The vertical scale is marked in terms of the time required for relay operation. If the P.S.M. is 10, then the time of operation (from the curve) is 3 seconds. The actual time of operation is obtained by multiplying this time by the time-setting multiplier.

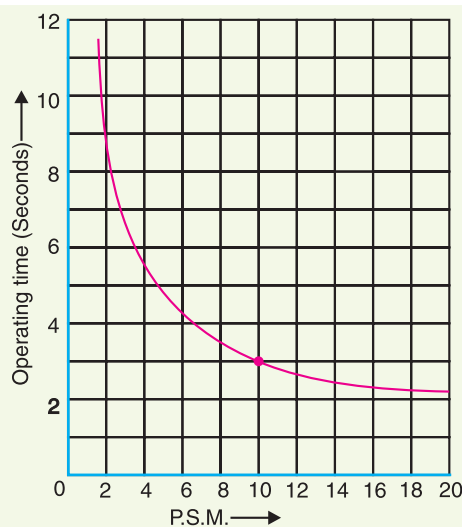

Fig. 21.16

It is evident from Fig. 21.16 that for lower values of overcurrent, time of operation varies inversely with the current but as the current approaches 20 times full-load value, the operating time of relay tends to become constant. This feature is necessary in order to ensure discrimination on very heavy fault currents flowing through sound feeders.

## 21.9 Calculation of Relay Operating Time

In order to calculate the actual relay operating time, the following things must be known :

- (a) Time/P.S.M. curve
- (b) Current setting
- (c) Time setting
- (d) Fault current
- (e) Current transformer ratio

The procedure for calculating the actual relay operating time is as follows :

- (i) Convert the fault current into the relay coil current by using the current transformer ratio.
- (ii) Express the relay current as a multiple of current setting *i.e.* calculate the P.S.M.
- (iii) From the Time/P.S.M. curve of the relay, read off the time of operation for the calculated P.S.M.
- (iv) Determine the actual time of operation by multiplying the above time of the relay by time-setting multiplier in use.

**Example 21.1.** Determine the time of operation of a 5-ampere, 3-second overcurrent relay having a current setting of 125% and a time setting multiplier of 0.6 connected to supply circuit through a 400/5 current transformer when the circuit carries a fault current of 4000 A. Use the curve shown in Fig. 21.16.

**Solution.**

$$\text{Rated secondary current of C.T.} = 5 \text{ A}$$

$$\text{Pickup current} = 5 \times 1.25 = 6.25 \text{ A}$$

$$\text{Fault current in relay coil} = 4000 \times \frac{5}{400} = 50 \text{ A}$$

$$\therefore \text{Plug-setting multiplier (P.S.M.)} = \frac{50}{6.25} = 8$$

Corresponding to the plug-setting multiplier of 8 (See Fig. 21.16), the time of operation is 3.5 seconds.

$$\therefore \text{Actual relay operating time} = 3.5 \times \text{Time-setting} = 3.5 \times 0.6 = \mathbf{2.1 \text{ seconds}}$$

## 21.10 Functional Relay Types

Most of the relays in service on power system today operate on the principle of electromagnetic attraction or electromagnetic induction. Regardless of the principle involved, relays are generally classified according to the function they are called upon to perform in the protection of electric power circuits. For example, a relay which recognises overcurrent in a circuit (*i.e.* current greater than that which can be tolerated) and initiates corrective measures would be termed as an *overcurrent relay* irrespective of the relay design. Similarly an *overvoltage relay* is one which recognises over-voltage in a circuit and initiates the corrective measures. Although there are several types of special-function relays, only the following important types will be discussed in this chapter :

- (i) Induction type overcurrent relays
- (ii) Induction type reverse power relays
- (iii) Distance relays
- (iv) Differential relays
- (v) Translay scheme

### 21.11 Induction Type Overcurrent Relay (*non-directional*)

This type of relay works on the induction principle and initiates corrective measures when current in the circuit exceeds the predetermined value. The actuating source is a current in the circuit supplied to the relay from a current transformer. These relays are used on a.c. circuits only and can operate for fault current flow in either direction.

**Constructional details.** Fig. 21.17 shows the important constructional details of a typical non-directional induction type overcurrent relay. It consists of a metallic (aluminium) disc which is free to rotate in between the poles of two electromagnets. The upper electromagnet has a primary and a secondary winding. The primary is connected to the secondary of a C.T. in the line to be protected and is tapped at intervals. The tappings are connected to a plug-setting bridge by which the number of active turns on the relay operating coil can be varied, thereby giving the desired current setting. The secondary winding is energised by induction from primary and is connected in series with the winding on the lower magnet. The controlling torque is provided by a spiral spring.

The spindle of the disc carries a moving contact which bridges two fixed contacts (connected to trip circuit) when the disc rotates through a pre-set angle. This angle can be adjusted to any value between  $0^\circ$  and  $360^\circ$ . By adjusting this angle, the travel of the moving contact can be adjusted and hence the relay can be given any desired time setting.

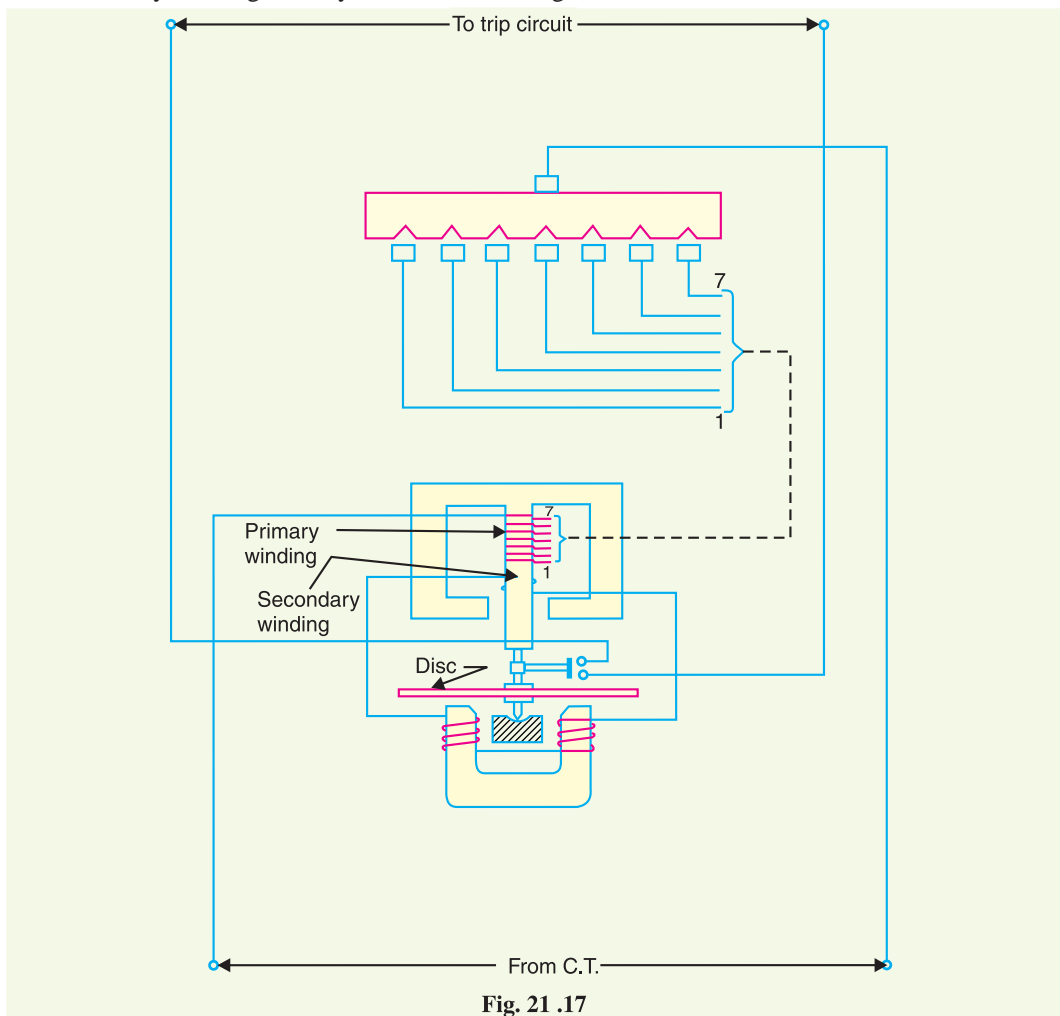

Fig. 21 .17

**Operation.** The driving torque on the aluminium disc is set up due to the induction principle as discussed in Art. 21.5. This torque is opposed by the restraining torque provided by the spring. Under normal operating conditions, restraining torque is greater than the driving torque produced by the relay coil current. Therefore, the aluminium disc remains stationary. However, if the current in the protected circuit exceeds the pre-set value, the driving torque becomes greater than the restraining torque. Consequently, the disc rotates and the moving contact bridges the fixed contacts when the disc has rotated through a pre-set angle. The trip circuit operates the circuit breaker which isolates the faulty section.

### 21.12 Induction Type Directional Power Relay

This type of relay operates when power in the circuit flows in a specific direction. Unlike a \*non-directional overcurrent relay, a directional power relay is so designed that it obtains its operating torque by the interaction of magnetic fields derived from both voltage and current source of the circuit it protects. Thus this type of relay is essentially a wattmeter and the direction of the torque set up in the relay depends upon the direction of the current relative to the voltage with which it is associated.

**Constructional details.** Fig. 21.18 shows the essential parts of a typical induction type directional power relay. It consists of an aluminum disc which is free to rotate in between the poles of two electromagnets. The upper electromagnet carries a winding (called *potential coil*) on the central limb which is connected through a potential transformer (P.T.) to the circuit voltage source. The lower electromagnet has a separate winding (called *current coil*) connected to the secondary of C.T. in the line to be protected. The current coil is provided with a number of tapings connected to the plug-setting bridge (not shown for clarity). This permits to have any desired current setting. The restraining torque is provided by a spiral spring.

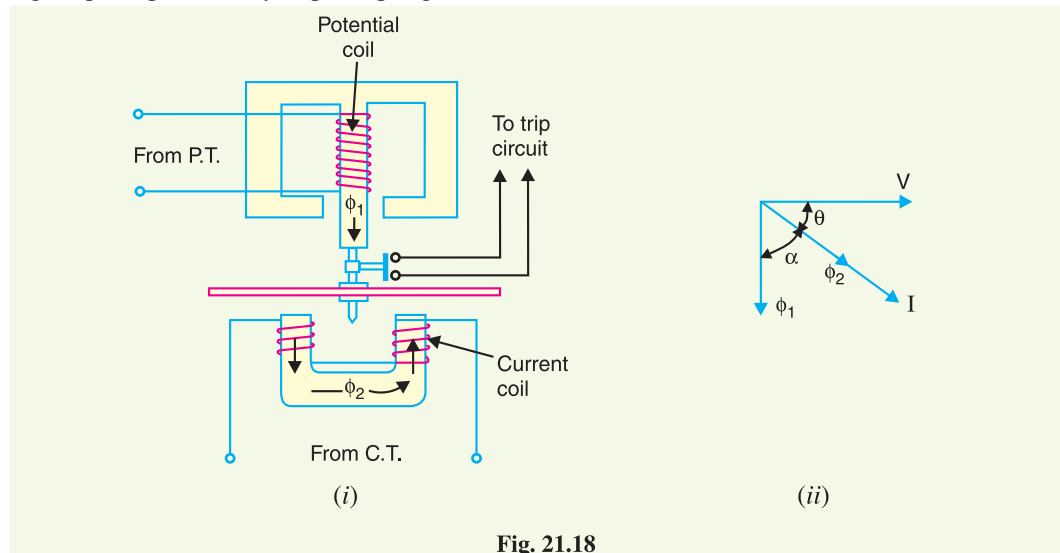

Fig. 21.18

The spindle of the disc carries a moving contact which bridges two fixed contacts when the disc has rotated through a pre-set angle. By adjusting this angle, the travel of the moving disc can be adjusted and hence any desired time-setting can be given to the relay.

**Operation.** The flux  $\phi_1$  due to current in the potential coil will be nearly  $90^\circ$  lagging behind the applied voltage  $V$ . The flux  $\phi_2$  due to current coil will be nearly in phase with the operating current  $I$

\* where the driving torque is due to the interaction of magnetic fields derived from current in the relay winding.

[See vector diagram in Fig. 21.18 (ii)]. The interaction of fluxes  $\phi_1$  and  $\phi_2$  with the eddy currents induced in the disc produces a driving torque given by :

$$T \propto \phi_1 \phi_2 \sin \alpha \quad [\text{See Art. 21.5}]$$

$$\text{Since } \phi_1 \propto V, \quad \phi_2 \propto I \quad \text{and} \quad \alpha = 90 - \theta$$

$$\therefore T \propto V I \sin (90 - \theta)$$

$$\propto V I \cos \theta$$

$$\propto \text{power in the circuit}$$

It is clear that the direction of driving torque on the disc depends upon the direction of power flow in the circuit to which the relay is associated. When the power in the circuit flows in the normal direction, the driving torque and the restraining torque (due to spring) help each other to turn away the moving contact from the fixed contacts. Consequently, the relay remains inoperative. However, the reversal of current in the circuit reverses the direction of driving torque on the disc. When the reversed driving torque is large enough, the disc rotates in the reverse direction and the moving contact closes the trip circuit. This causes the operation of the circuit breaker which disconnects the faulty section.

### 21.13 Induction Type Directional Overcurrent Relay

The directional power relay discussed above is unsuitable for use as a directional protective relay under short-circuit conditions. When a short-circuit occurs, the system voltage falls to a low value and there may be \*insufficient torque developed in the relay to cause its operation. This difficulty is overcome in the directional overcurrent relay which is designed to be almost independent of system voltage and power factor.

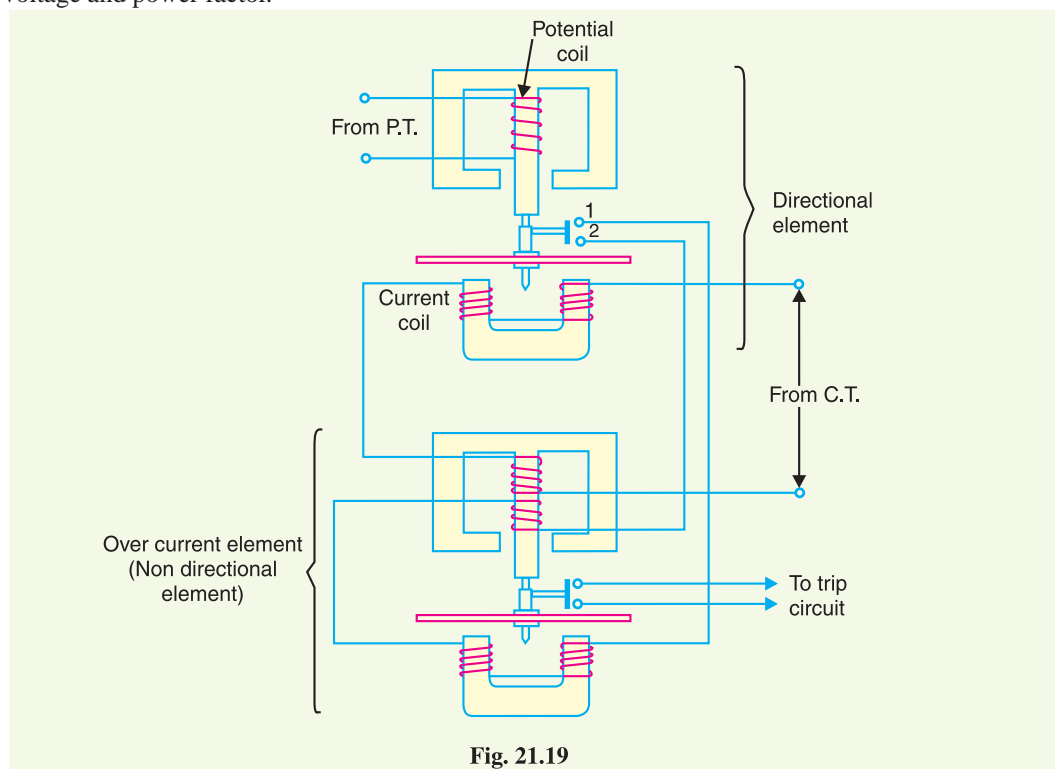

Fig. 21.19

\* Directional power relay being of wattmeter type, the driving torque on the disc also depends upon the system voltage.

**Constructional details.** Fig. 21.19 shows the constructional details of a typical induction type directional overcurrent relay. It consists of two relay elements mounted on a common case *viz.* (i) directional element and (ii) non-directional element.

(i) **Directional element.** It is essentially a directional power relay which operates when power flows in a specific direction. The potential coil of this element is connected through a potential transformer (P.T.) to the system voltage. The current coil of the element is energised through a C.T. by the circuit current. This winding is carried over the upper magnet of the non-directional element. The trip contacts (1 and 2) of the directional element are connected in series with the secondary circuit of the overcurrent element. Therefore, the latter element cannot start to operate until its secondary circuit is completed. In other words, the directional element must operate first (*i.e.* contacts 1 and 2 should close) in order to operate the overcurrent element.

(ii) **Non-directional element.** It is an overcurrent element similar in all respects to a non-directional overcurrent relay described in Art. 21.11. The spindle of the disc of this element carries a moving contact which closes the fixed contacts (trip circuit contacts) after the operation of directional element.

It may be noted that plug-setting bridge is also provided in the relay for current setting but has been omitted in the figure for clarity and simplicity. The tappings are provided on the upper magnet of overcurrent element and are connected to the bridge.

**Operation.** Under normal operating conditions, power flows in the normal direction in the circuit protected by the relay. Therefore, directional power relay (upper element) does not operate, thereby keeping the overcurrent element (lower element) unenergised. However, when a short-circuit occurs, there is a tendency for the current or power to flow in the reverse direction. Should this happen, the disc of the \*upper element rotates to bridge the fixed contacts 1 and 2. This completes the circuit for overcurrent element. The disc of this element rotates and the moving contact attached to it closes the trip circuit. This operates the circuit breaker which isolates the faulty section. The two relay elements are so arranged that final tripping of the current controlled by them is not made till the following conditions are satisfied :

- (i) current flows in a direction such as to operate the directional element.
- (ii) current in the reverse direction exceeds the pre-set value.
- (iii) excessive current persists for a period corresponding to the time setting of overcurrent element.

### 21.14 Distance or Impedance Relays

The operation of the relays discussed so far depended upon the magnitude of current or power in the protected circuit. However, there is another group of relays in which the operation is governed by the ratio of applied voltage to current in the protected circuit. Such relays are called distance or \*\*impedance relays. In an impedance relay, the torque produced by a current element is opposed by the torque produced by a voltage element. The relay will operate when the ratio  $V/I$  is less than a pre-determined value.

Fig. 21.20 illustrates the basic principle of operation of an impedance relay. The voltage element of the relay is excited through a potential transformer (P.T.) from the line to be protected. The current element of the relay is excited from a current transformer (C.T.) in series with the line. The portion  $AB$  of the line is the protected zone. Under normal operating conditions, the impedance of the protected zone is  $Z_L$ . The relay is so designed that it closes its contacts whenever impedance of the protected section falls below the pre-determined value *i.e.*  $Z_L$  in this case.

\* The directional element is made very sensitive so that with the lowest value of voltage which may be anticipated under severe fault conditions, sufficient torque is produced by the current winding to complete the operation of the element and allow its contacts to close.

\*\* Impedance is an electrical measure of distance along a transmission line.

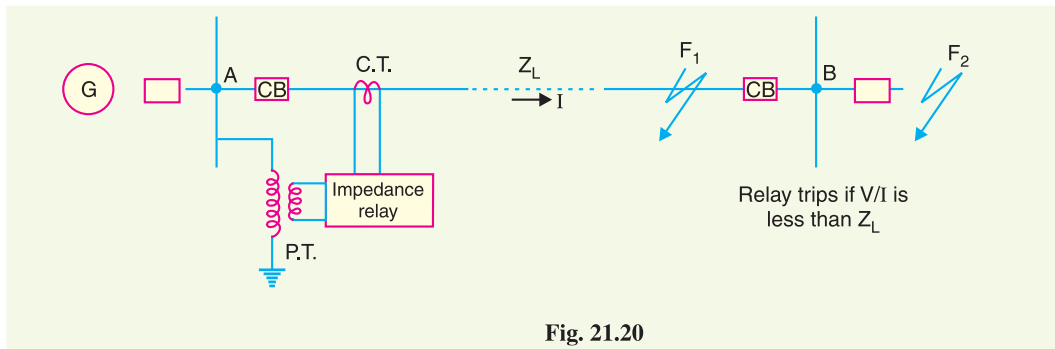

Fig. 21.20

Now suppose a fault occurs at point  $F_1$  in the protected zone. The impedance  $Z (= V/I)$  between the point where the relay is installed and the point of fault will be less than  $Z_L$  and hence the relay operates. Should the fault occur beyond the protected zone (say point  $F_2$ ), the impedance  $Z$  will be greater than  $Z_L$  and the relay does not operate.

**Types.** A distance or impedance relay is essentially an ohmmeter and operates whenever the impedance of the protected zone falls below a pre-determined value. There are two types of distance relays in use for the protection of power supply, namely ;

- (i) **Definite-distance relay** which operates instantaneously for fault upto a pre-determined distance from the relay.
- (ii) **Time-distance relay** in which the time of operation is proportional to the distance of fault from the relay point. A fault nearer to the relay will operate it earlier than a fault farther away from the relay.

It may be added here that the distance relays are produced by modifying either of two types of basic relays; the balance beam or the induction disc.

### 21.15 Definite – Distance Type Impedance Relay

Fig. 21.21 shows the schematic arrangement of a definite-distance type impedance relay. It consists of a pivoted beam  $F$  and two electromagnets energised respectively by a current and voltage transformer in the protected circuit. The armatures of the two electromagnets are mechanically coupled to the beam on the opposite sides of the fulcrum. The beam is provided with a bridging piece for the trip contacts. The relay is so designed that the torques produced by the two electromagnets are in the opposite direction.

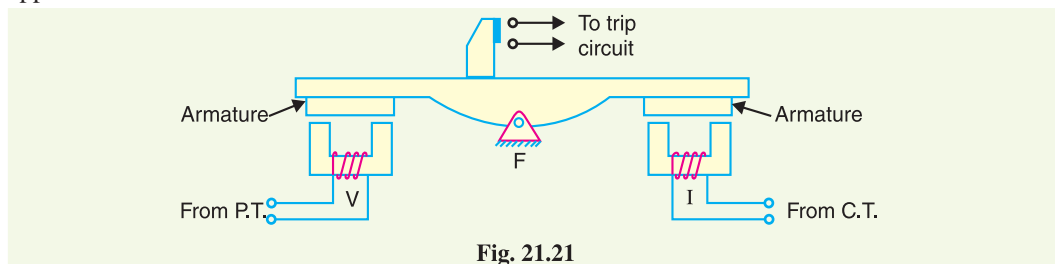

Fig. 21.21

**Operation.** Under normal operating conditions, the pull due to the voltage element is **\*\***greater than that of the current element. Therefore, the relay contacts remain open. However, when a fault occurs in the protected zone, the applied voltage to the relay decreases whereas the current increases. The ratio of voltage to current (*i.e.* impedance) falls below the pre-determined value. Therefore, the

\* where  $I$  is the fault current and  $V$  is the voltage at the sub-station.

\*\* Because the current  $I$  corresponds to normal load :



pull of the current element will exceed that due to the voltage element and this causes the beam to tilt in a direction to close the trip contacts.

The pull of the current element is proportional to  $I^2$  and that of voltage element to  $V^2$ . Consequently, the relay will operate when

$$k_1 V^2 < k_2 I^2$$

or 
$$\frac{V^2}{I^2} < \frac{k_2}{k_1}$$

or 
$$\frac{V}{I} < \sqrt{\frac{k_2}{k_1}}$$

or 
$$Z < \sqrt{\frac{k_2}{k_1}}$$

The value of the constants  $k_1$  and  $k_2$  depends upon the ampere-turns of the two electromagnets. By providing tapings on the coils, the setting value of the relay can be changed.

### 21.16 Time-Distance Impedance Relay

A time-distance impedance relay is one which automatically adjusts its operating time according to the distance of the relay from the fault point *i.e.*

$$\begin{aligned} \text{Operating time, } T &\propto V/I \\ &\propto Z \\ &\propto \text{distance} \end{aligned}$$

**Construction.** Fig. 21.22 shows the schematic arrangement of a typical induction type time-distance impedance relay. It consists of a current driven induction element similar to the double-winding type induction overcurrent relay (refer back to Fig. 21.8). The spindle carrying the disc of this element is connected by means of a spiral spring coupling to a second spindle which carries the bridging piece of the relay trip contacts. The bridge is normally held in the open position by an armature held against the pole face of an electromagnet excited by the voltage of the circuit to be protected.

**Operation.** Under normal load conditions, the pull of the armature is more than that of the induction element and hence the trip circuit contacts remain open. However, on the occurrence of a short-circuit, the disc of the induction current element starts to rotate at a speed depending upon the operating current. As the rotation of the disc proceeds, the spiral spring coupling is wound up till the tension of the spring is sufficient to pull the armature away from the pole face of the \*voltage-excited magnet. Immediately this occurs, the spindle carrying the armature and bridging piece moves rapidly in response to the tension of the spring and trip contacts are closed. This opens the circuit breaker to isolate the faulty section.

The speed of rotation of the disc is approximately proportional to the operating current, neglecting the effect of control spring. Also the time of operation of the relay is directly proportional to the pull of the voltage-excited magnet and hence to the line voltage  $V$  at the point where the relay is connected. Therefore, the time of operation of relay would vary as  $V/I$  *i.e.* as  $Z$  or distance.

\* The angle through which the disc travels before relay operates depends upon the pull of the voltage-excited magnet. The greater the pull, the greater will be the travel of the disc. The pull of this magnet depends upon the line voltage. The greater the line voltage, the greater the pull and hence larger will be the travel of the disc *i.e.* operating time  $\propto V$ .

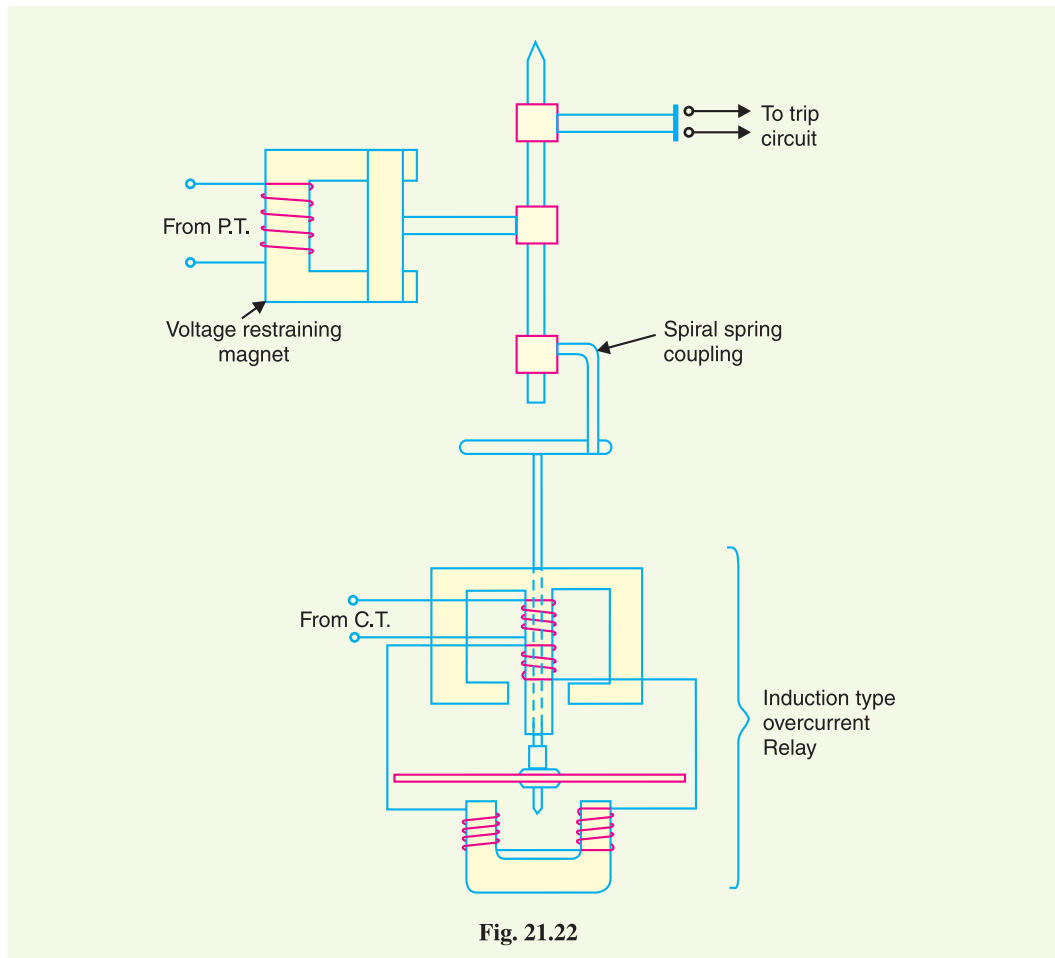

Fig. 21.22

### 21.17 Differential Relays

Most of the relays discussed so far relied on excess of current for their operation. Such relays are less sensitive because they cannot make correct distinction between heavy load conditions and minor fault conditions. In order to overcome this difficulty, differential relays are used.

A **differential relay** is one that operates when the phasor difference of two or more similar electrical quantities exceeds a pre-determined value.

Thus a current differential relay is one that compares the current entering a section of the system with the current leaving the section. Under normal operating conditions, the two currents are equal but as soon as a fault occurs, this condition no longer applies. The difference between the incoming and outgoing currents is arranged to flow through the operating coil of the relay. If this differential current is equal to or greater than the pickup value, the relay will operate and open the circuit breaker to isolate the faulty section.

It may be noted that almost any type of relay when connected in a particular way can be made to operate as a differential relay. In other words, it is not so much the relay construction as the way the relay is connected in a circuit that makes it a differential relay. There are two fundamental systems of differential or balanced protection viz.

- (i) Current balance protection
- (ii) Voltage balance protection

### 21.18 Current Differential Relay

Fig. 21.23 shows an arrangement of an overcurrent relay connected to operate as a differential relay. A pair of identical current transformers are fitted on either end of the section to be protected (alternator winding in this case). The secondaries of CT's are connected in series in such a way that they carry the induced currents in the same direction. The operating coil of the overcurrent relay is connected across the CT secondary circuit. This differential relay compares the current at the two ends of the alternator winding.

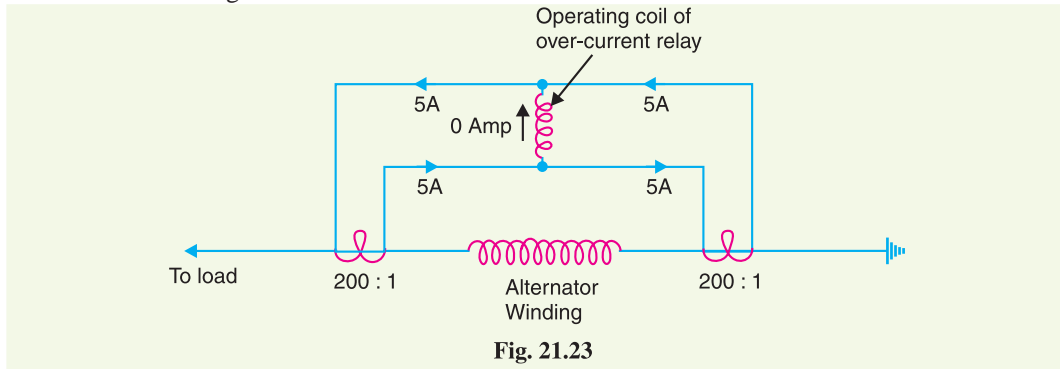

Under normal operating conditions, suppose the alternator winding carries a normal current of 1000 A. Then the currents in the two secondaries of CT's are equal [See Fig. 21.23]. These currents will merely circulate between the two CT's and no current will flow through the differential relay. Therefore, the relay remains inoperative. If a ground fault occurs on the alternator winding as shown in Fig. 21.24 (i), the two secondary currents will not be equal and the current flows through the operating coil of the relay, causing the relay to operate. The amount of current flow through the relay will depend upon the way the fault is being fed.

- (i) If some current (500 A in this case) flows out of one side while a larger current (2000 A) enters the other side as shown in Fig. 21.24 (i), then the difference of the CT secondary currents *i.e.*  $10 - 2.5 = 7.5$  A will flow through the relay.

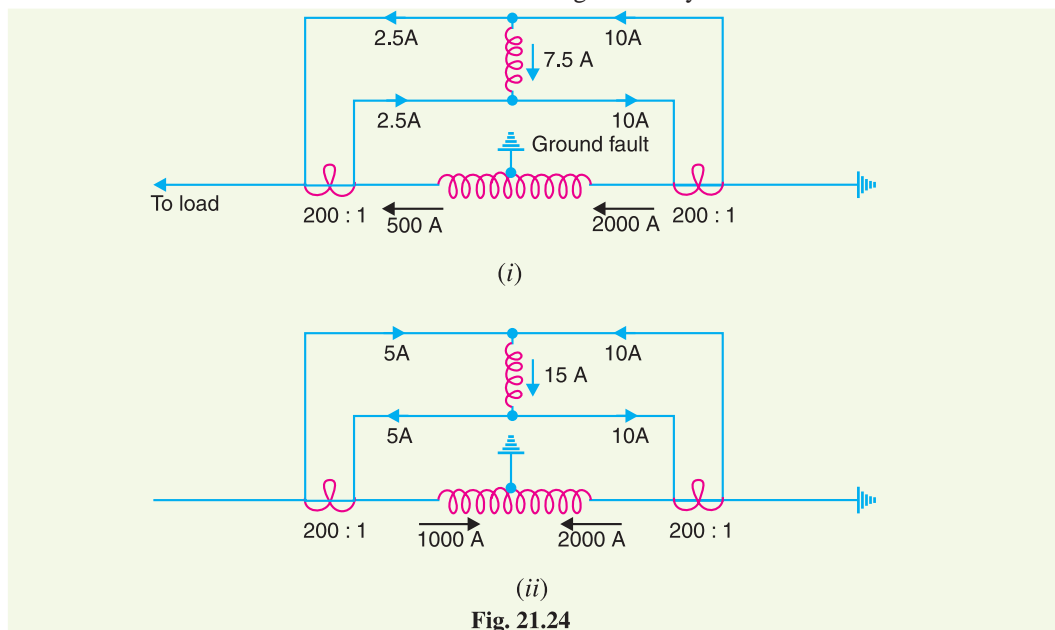

- (ii) If current flows to the fault from both sides as shown in Fig. 21.24 (ii), then sum of CT secondary currents *i.e.*  $10 + 5 = 15$  A will flow through the relay.

#### Disadvantages

- (i) The impedance of the \*pilot cables generally causes a slight difference between the currents at the two ends of the section to be protected. If the relay is very sensitive, then the small differential current flowing through the relay may cause it to operate even under no fault conditions.
- (ii) Pilot cable capacitance causes incorrect operation of the relay when a large through-current flows.
- (iii) Accurate matching of current transformers cannot be achieved due to pilot circuit impedance.

The above disadvantages are overcome to a great extent in biased beam relay.

**Biased Beam Relay.** The biased beam relay (also called *percentage differential relay*) is designed to respond to the differential current in terms of its fractional relation to the current flowing through the protected section. Fig. 21.25 shows the schematic arrangement of a biased beam relay. It is essentially an overcurrent balanced beam relay type with an additional restraining coil. The restraining coil produces a bias force in the opposite direction to the operating force.

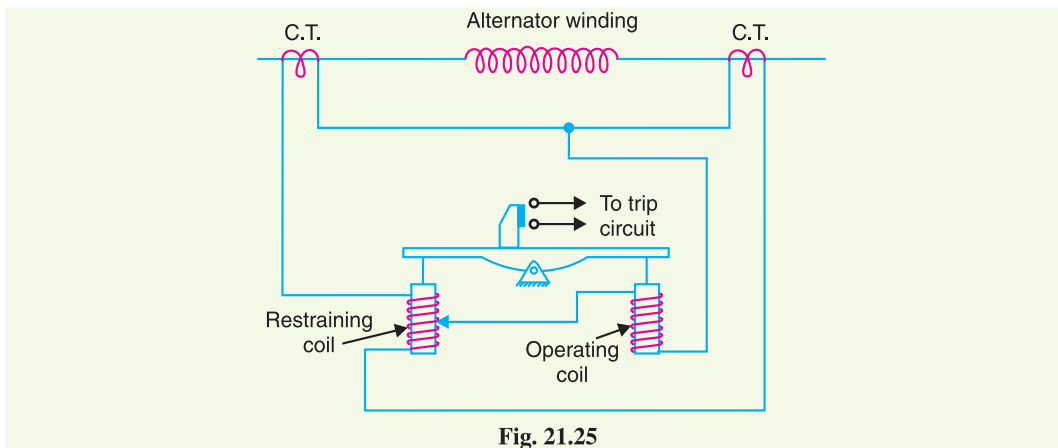

Fig. 21.25

Under normal and through load conditions, the bias force due to restraining coil is greater than the operating force. Therefore, the relay remains inoperative. When an internal fault occurs, the operating force exceeds the bias force. Consequently, the trip contacts are closed to open the circuit breaker. The bias force can be adjusted by varying the number of turns on the restraining coil.

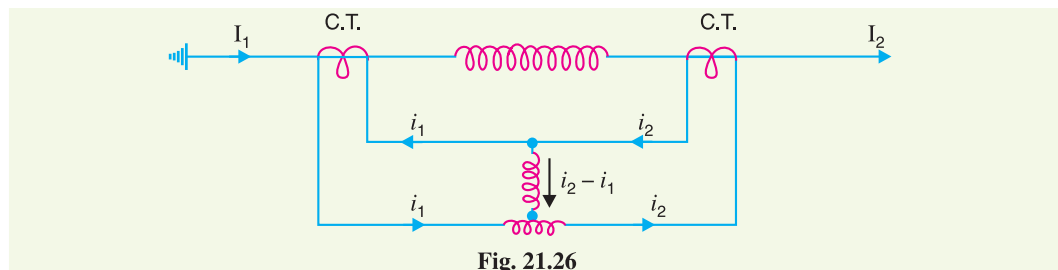

Fig. 21.26

The equivalent circuit of a biased beam relay is shown in Fig. 21.26. The differential current in the operating coil is proportional to  $i_2 - i_1$  and the equivalent current in the restraining coil is propor-

\* The two CT's are connected through conductors called pilot cable. If the two ends of the section to be protected are quite apart, the impedance of pilot-cable may be large, say of the order of  $500 \Omega$ .

tional to  $*(i_1 + i_2)/2$  since the operating coil is connected to the mid-point of the restraining coil. It is clear that greater the current flowing through the restraining coil, the higher the value of current required in the operating winding to trip the relay. Thus under a heavy load, a greater differential current through the relay operating coil is required for operation than under light load conditions. This relay is called *percentage relay* because the operating current required to trip can be expressed as a percentage of load current.

### 21.19 Voltage Balance Differential Relay

Fig. 21.27 shows the arrangement of voltage balance protection. In this scheme of protection, two similar current transformers are connected at either end of the element to be protected (*e.g.* an alternator winding) by means of pilot wires. The secondaries of current transformers are connected in series with a relay in such a way that under normal conditions, their induced e.m.f.s' are in opposition.

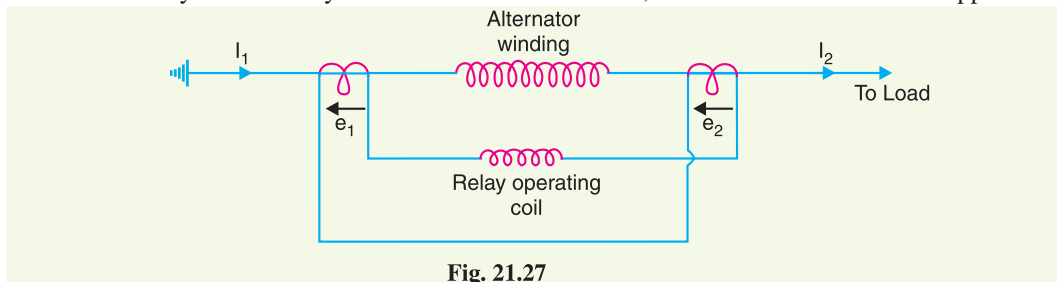

Fig. 21.27

Under healthy conditions, equal currents ( $I_1 = I_2$ ) flow in both primary windings. Therefore, the secondary voltages of the two transformers are balanced against each other and no current will flow through the relay operating coil. When a fault occurs in the protected zone, the currents in the two primaries will differ from one another (*i.e.*  $I_1 \neq I_2$ ) and their secondary voltages will no longer be in balance. This voltage †difference will cause a current to flow through the operating coil of the relay which closes the trip circuit.

#### Disadvantages

The voltage balance system suffers from the following drawbacks :

- (i) A multi-gap transformer construction is required to achieve the accurate balance between current transformer pairs.
- (ii) The system is suitable for protection of cables of relatively short lengths due to the capacitance of pilot wires. On long cables, the charging current may be sufficient to operate the relay even if a perfect balance of current transformers is attained.

The above disadvantages have been overcome in Translay (modified) balanced voltage system.

### 21.20 Translay System

This system is the modified form of voltage-balance system. Although the principle of balanced (opposed) voltages is retained, it differs from the above voltage-balance system in that the balance or opposition is between voltages induced in the secondary coils wound on the relay magnets and *not* between the secondary voltages of the line current transformers. Since the current transformers used

\* Total ampere-turns on restraining coil of  $N$  turns

$$\begin{aligned} &\propto i_1 \frac{N}{2} + i_2 \frac{N}{2} \\ &\propto (i_1 + i_2) \frac{N}{2} \end{aligned}$$

This is the same as if current  $(i_1 + i_2)/2$  were to flow through the whole restraining coil.

† This is the case when fault is fed in one direction. Should the fault be fed from both ends, the secondary voltages become additive and increase the out-of-balance current operating the relay.

with Translay scheme have only to supply to a relay coil, they can be made of normal design without any air gaps. This permits the scheme to be used for feeders of any voltage.

**Constructional details.** Fig. 21.28 shows the simplified diagram illustrating the principle of \*Translay scheme. It consists of two identical double winding induction type relays fitted at either end of the feeder to be protected. The primary circuits (11, 11a) of these relays are supplied through a pair of current transformers. The secondary windings (12, 13 and 12a, 13a) of the two relays are connected in series by pilot wires in such a way that voltages induced in the former opposes the other. The compensating devices (18, 18a) neutralise the effects of pilot-wire capacitance currents and of inherent lack of balance between the two current transformers.

**Operation.** Under healthy conditions, current at the two ends of the protected feeder is the same and the primary windings (11, 11a) of the relays carry the same current. The windings 11 and 11a induce equal e.m.f.s in the secondary windings 12, 12a and 13, 13a. As these windings are so connected that their induced voltages are in opposition, no current will flow through the pilots or operating coils and hence no torque will be exerted on the disc of either relay. In the event of fault on the protected feeder, current leaving the feeder will differ from the current entering the feeder. Consequently, unequal voltages will be induced in the secondary windings of the relays and current will circulate between the two windings, causing the torque to be exerted on the disc of each relay. As the direction of secondary current will be opposite in the two relays, therefore, the torque in one relay will tend to close the trip circuit while in the other relay, the torque will hold the movement in the normal unoperated position. It may be noted that resulting operating torque depends upon the position and nature of the fault in the protected zone and atleast one element of either relay will operate under any fault condition.

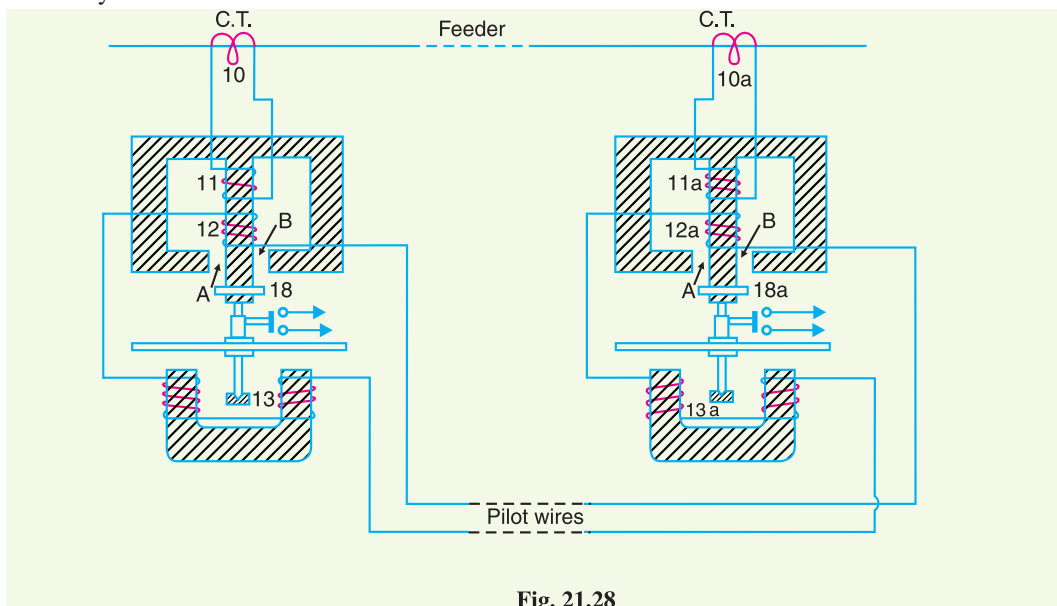

Fig. 21.28

It is worthwhile here to mention the role of closed copper rings (18, 18a) in neutralising the effects of pilot capacitive currents. Capacitive currents lead the voltage impressed across the pilots by  $90^\circ$  and when they flow in the operating winding 13 and 13a (which are of low inductance), they produce fluxes that also lead the pilot voltage by  $90^\circ$ . Since pilot voltage is that induced in the secondary windings 12 and 12a, it lags by a substantial angle behind the fluxes in the field magnet air gaps A and B. The closed copper rings (18, 18a) are so adjusted that this angle is approximately  $90^\circ$ . In this way fluxes acting on the disc are in phase and hence no torque is exerted on the relay disc.

\* The relays used embrace the function of transformer as well as relay. Hence the name Translay.

### 21.21 Types of Protection

When a fault occurs on any part of electric power system, it must be cleared quickly in order to avoid damage and/or interference with the rest of the system. It is a usual practice to divide the protection scheme into two classes *viz.* primary protection and back-up protection.

- (i) **Primary Protection.** It is the protection scheme which is designed to protect the component parts of the power system. Thus referring to Fig. 21.29, each line has an overcurrent relay that protects the line. If a fault occurs on any line, it will be cleared by its relay and circuit breaker. This forms the primary or main protection and serves as the first line of defence. The service record of primary relaying is very high with well over ninety percent of all operations being correct. However, sometimes faults are not cleared by primary relay system because of trouble within the relay, wiring system or breaker. Under such conditions, back-up protection does the required job.

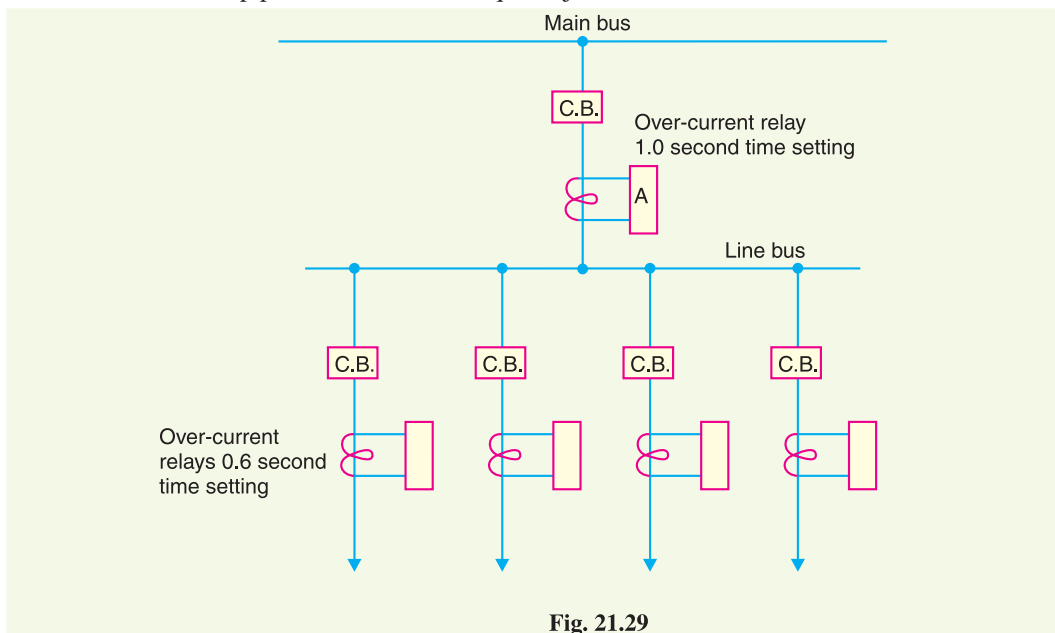

Fig. 21.29

- (ii) **Back-up protection.** It is the second line of defence in case of failure of the primary protection. It is designed to operate with sufficient time delay so that primary relaying will be given enough time to function if it is able to. Thus referring to Fig. 21.29, relay A provides back-up protection for each of the four lines. If a line fault is not cleared by its relay and breaker, the relay A on the group breaker will operate after a definite time delay and clear the entire group of lines. It is evident that when back-up relaying functions, a larger part is disconnected than when primary relaying functions correctly. Therefore, greater emphasis should be placed on the better maintenance of primary relaying.

### SELF - TEST

1. Fill in the blanks by inserting appropriate words/figures.

- (i) A relay performs the function of .....
- (ii) The relay operating coil is supplied through .....
- (iii) A 1 VA relay is ..... sensitive than a 3 VA relay.
- (iv) The minimum relay coil current at which the relay operates is called.....

- (v) Induction relays ..... be used with d.c. quantities.
  - (vi) An overcurrent relay having a current setting of 125% is connected to a supply circuit through a current transformer of ratio 400/5. The pick-up value will be .....
  - (vii) The pick-up value of a relay is 7.5 A and fault current in relay coil is 30A. Its plug-setting multiplier is .....
  - (viii) Back-up protection functions when .....
- 2. Pick up the correct words/figures from brackets and fill in the blanks.**
- (i) Most of the relays on service on electric power system are ..... relays.  
(*electronic, electro-mechanical*)
  - (ii) Induction relays are used with ..... quantities. (*a.c., d.c., both a.c. and d.c.*)
  - (iii) Back-up protection is generally employed for protection against ..... faults.  
(*short-circuit, other than short-circuit*)
  - (iv) Back-up protection is generally of ..... type. (*unit, non-unit*)

### ANSWERS TO SELF-TEST

1. (i) fault detection (ii) instrument transformers (iii) more (iv) pick-up value (v) cannot (vi) 6-25 A (vii) 4 (viii) primary protection fails
2. (i) electro-mechanical (ii) a.c. (iii) short-circuit (iv) non-unit.

### CHAPTER REVIEW TOPICS

1. What is protective relay ? Explain its function in an electrical system.
2. Discuss the fundamental requirements of protective relaying.
3. Describe briefly some important types of electromagnetic attraction relays.
4. Derive the equation for torque developed in an induction relay.
5. Write a brief note on relay timing.
6. Define and explain the following terms as applied to protective relaying :  
(i) Pick-up value (ii) Current setting (iii) Plug-setting multiplier (iv) Time-setting multiplier
7. Sketch a typical time/P.S.M. curve.
8. Describe the various steps for calculating the actual relay operating time.
9. Explain with the help of neat diagram the construction and working of :  
(i) Non-directional induction type overcurrent relay  
(ii) Induction type directional power relay
10. Describe the construction and principle of operation of an induction type directional overcurrent relay.
11. Explain the working principle of distance relays.
12. Write a detailed note on differential relays.
13. Describe the Translay scheme of protection.
14. Write short notes on the following :  
(i) Percentage differential relays (ii) Definite distance relays (iii) Time-distance relays

### DISCUSSION QUESTIONS

1. What is the difference between a fuse and a relay ?
2. What is the difference between an overcurrent relay and current differential relay ?
3. Back-up protection is not a good substitute for better maintenance. Discuss.
4. Why are differential relays more sensitive than overcurrent relays ?
5. What is the difference between a balanced voltage relay and a Translay relay ?