

- **Bleaching:** A process where color bodies are destroyed and the fabric is whitened.
  - **Mercerizing:** Caustic treatment of cellulosic fabrics improving luster, water absorbance, dye yield and fiber strength.
  - **Carbonizing:** Acid treatment of wool for removing vegetable matter.
  - **Heat Setting:** Heat treatment of fabrics containing thermoplastic synthetic fibers. Stabilizes fabric by reducing shrinkage and distortion.
- 

## CHAPTER 1

# PREPARATION PROCESSES

---

Various types of equipment can be used for preparing fabric. The ultimate goal of any preparation process is to produce fabric that is clean and rid of all impurities that interfere with dyeing and finishing. The preparation steps can be carried out as either batch or continuous processes. The fabric may be transported as a rope or as an open sheet through the equipment. The choice is often predicated on the dye-house itself. The distinguishing feature of batch equipment is that all of the fabric is simultaneously submerged in the liquor. The fabric is agitated by moving it through the liquor. In continuous processes, the fabric passes non-stop through compartments and/or stages so that the fabric is incrementally subjected to the action of the chemicals. The equipment used for dyeing fabrics is also suitable for preparing fabric. In this section, the equipment used to perform fabric preparation will be described.

### I. YARN PREPARATION EQUIPMENT

*Slashing* is the process where *Size* is applied to warp yarns for weaving. The purpose of size is to protect the yarn from the abrasive action of the loom. The process is carried out on a *Slasher* and the application procedure is called *Sizing* or *Slashing*. While technically this process is not considered as a step in preparing

fabric, the materials used in this operation, to a large measure, account for the bulk of what must be removed. Because the desizing step is highly dependant on what size was used, it is deemed instructive to discuss the slashing process as well as discuss the nature of the sizing materials.

Figure 1 shows a schematic diagram of a slasher. In slashing, section beams are combined to create a loom beam and at the same time apply the appropriate size to the warp yarns. The section marked (1) is the let-off station where one or more section beams are combined and fed through the rest of the range. The warp yarns are let-off as a flat sheet and then pass through a size applicator (2) consisting of a trough containing the size formulation and squeeze rolls. The yarns pass over heated cans (3) to dry. Located at the exit end of the slasher is an arrangement of bust bars which separate each warp end from its neighbor. The individual warp ends pass through a reed which guides the yarn onto the take-up beam. Associated with the slasher is a cooking station, where the sizing material (starch or polyvinyl alcohol) is dissolved and stored. The solution is metered to the applicator as needed to replenish what has been taken up by the warp sheet. The chemical nature of the size will be discussed in a later section along with the conditions needed to effectively remove the size.

**Figure 1. Schematic of a Slasher**

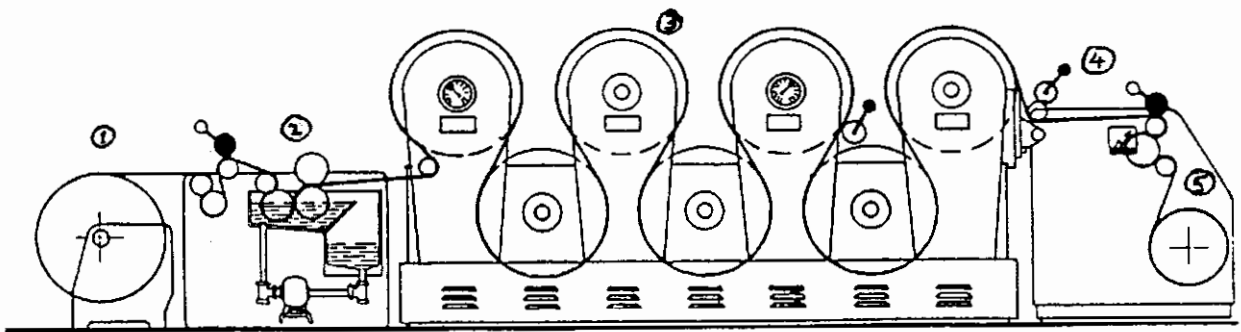

## II. FABRIC PREPARATION EQUIPMENT

### A. Batch Machines

In batch processing, machines are used where the entire load of fabric is immersed in the total amount of liquid needed for that process. These machines are primarily used to dye fabric, however, in many cases they are also used to prepare fabric prior to the dyeing cycle. The section that follows describes some of the more popular machines.

#### 1. Becks

A beck is the simplest type of wet processing batch equipment. It is a large vat which holds the entire lot of fabric. The fabric is fed into the machine in the form of a rope and is made into a continuous loop by sewing the two ends together. The length of the loop is equal to a piece length, usually 100 to 200 yards. The fabric is agitated by the action of a lifter wheel which gently moves the fabric through the liquor by lifting and dropping the rope in and out of the liquor. Lot size is determined by the number of loop strands that can be accommodated by the machine and is a function of the front width of the machine. Commercial machines are available ranging from one strand to 16 strands. A schematic of a beck is shown in figure 2.

**Figure 2. Schematic of an Atmospheric Beck**

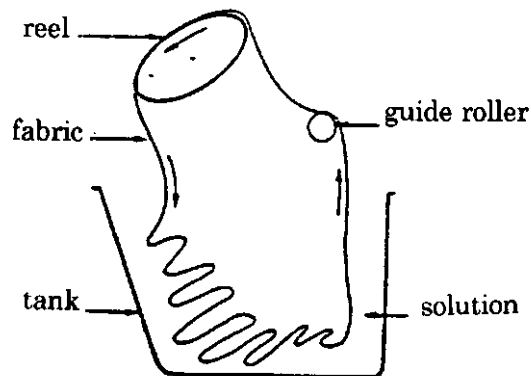

## 2. Jet Machines

Jet machines are similar to becks in that a continuous loop of fabric circulates through the machine. They differ however in that a stream of liquor is forced through a venturi tube. This provides the force to propel the fabric through the machine. Temperatures in Jet machines that operate at atmospheric pressure cannot exceed the boiling point of water; however, higher temperatures can be obtained in those that are operated under pressure. An advantage of the jet machines is that lower liquor ratios can be used. In a beck, the liquid is stationary and the fabric moves through it. In a jet however, both the liquid and the fabric move in relation to each other. This increases the rate of interchange between the liquid and fabric and speeds up the process. The distinguishing features of jet machines are the venturi tubes which create the force to circulate fabric, and circulating pumps which cycle the bath through the venturi tubes. Figures 3 shows schematic diagrams of pressure and atmospheric jets.

**Figure 3. Schematics of Jet Machines**

### Atmospheric Jet

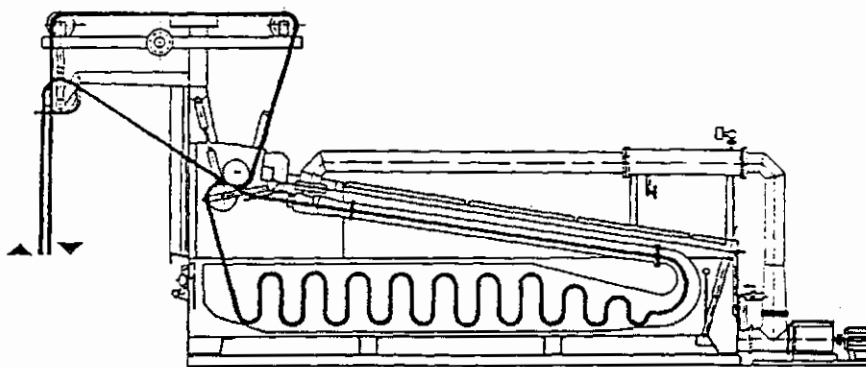

### Pressure Jet

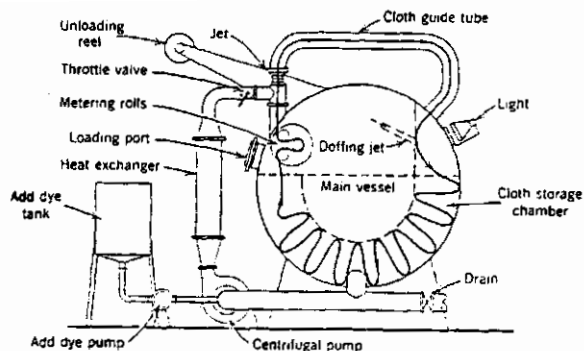

<sup>4</sup> Schematic view of jet dyeing machine. (Courtesy of Gaston County Dyeing Machine Co., Stanley, North Carolina, U.S.A.)

### 3. Jig

A Jig or Jigger is a batch machine which handles fabric in open width. It is a simple machine consisting of let-off and take-up rolls, a trough containing the processing liquor and guide rolls which allow the fabric to pass from the let-off to the take-up roll. After all the fabric transfers, the driving mechanism is reversed and the fabric makes a second pass through the liquor by returning to the original let-off roll. The cycle can be repeated as many times as it takes to achieve the desired effect. Figure 4 shows a schematic of a jig.

**Figure 4. Schematic of a Jig**

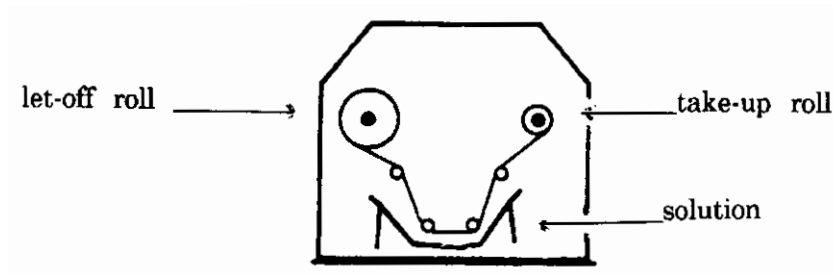

### B. Continuous Preparation. Ranges

Continuous ranges are used whenever large volumes of a relative few styles of fabrics are being processed. The fabric moves continuously (at relative high rates of speed) through stages and compartments which provide the chemicals, time, temperature and rinsing needed for cleaning the fabric. Many fabrics go through a three section range where each section is dedicated to desize, to scour and to bleach. Some fabrics however, may only require one or two steps to complete the preparation process. For example knit goods are not sized so desizing is not necessary. Synthetic yarns may not need to be bleached. Some fabrics may go through one section where desizing, scouring and bleaching is accomplished in one step. The pros and cons of each of these set-ups become fabric specific and the appropriate procedure is determined by trial and error.

Each stage contains three substations: an applicator where the fabric is impregnated with appropriate chemicals, a holding station which provides reaction time and temperature and finally a washing station for flushing out the impurities. The equipment is designed for handling the fabric as a continuous rope or as an open width sheet. An open width range needs more sophisticated equipment such edge guide rollers, fabric spreaders and steam chambers to keep the fabric flat and smooth. A rope range need not be as sophisticated.

## 1. Continuous Rope Range

Figure 5 shows the schematic of a rope range. This drawing only include scouring and bleaching stages. Each stage contains a saturator, J-box and rope washers.

**Figure 5. Schematic of a Continuous Rope Range**

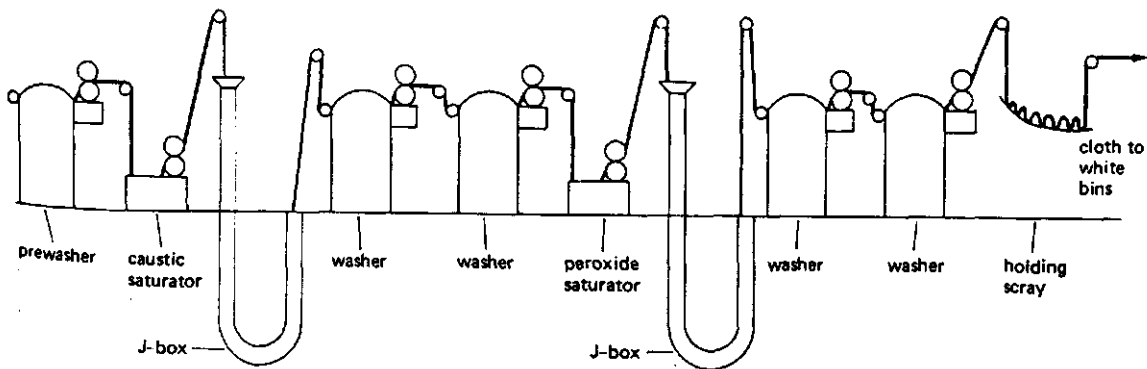

The heart of a rope range is the J-box which is detailed in figure 6. The saturated fabric is plaited into the top leg of the J and feeds by gravity out through the lower leg. The size of the J-box depends on the dwell time and the speed of the range. These boxes are usually jacketed and steam heated.

**Figure 6. Schematic of a J-Box**

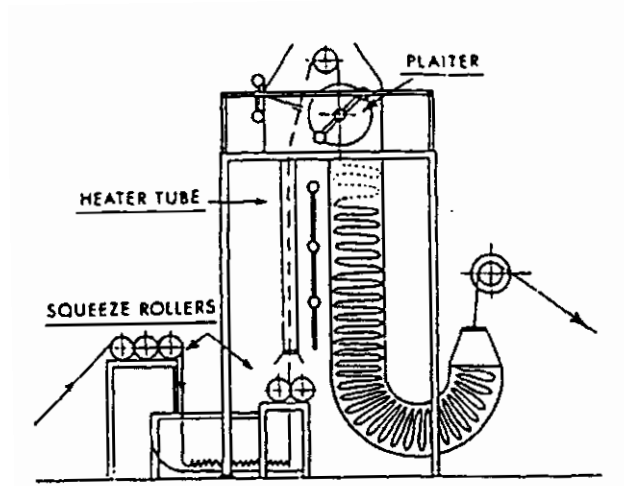

More details of a preparation utilizing J-boxes is seen in figure 7.. The saturator is placed in front of a J-box and the washers are placed immediately after. Without pause, the fabric exits the washer and enters the next saturator. The sequence saturatorg J-box g washer is repeated until all of the preparation steps are completed.

**Figure 7. Details of Continuous Rope Range**

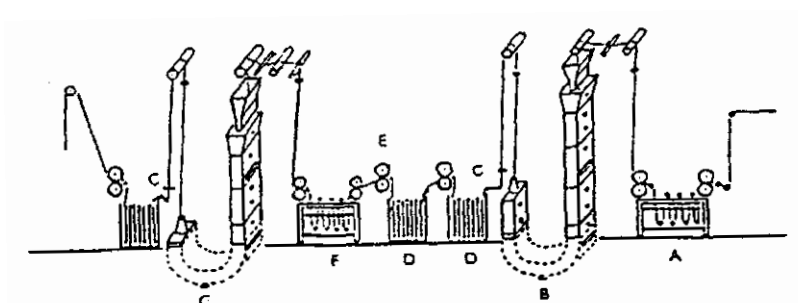

## 2. Continuous Open Width Range

An open width range differs from a rope range only to the extent that the fabric handling equipment is different. The chemicals, temperatures and dwell times, for the most part are the same as that for a rope range. A schematic of an open width range is seen in figure 8.

**Figure 8. Schematic of an Open Width Range**

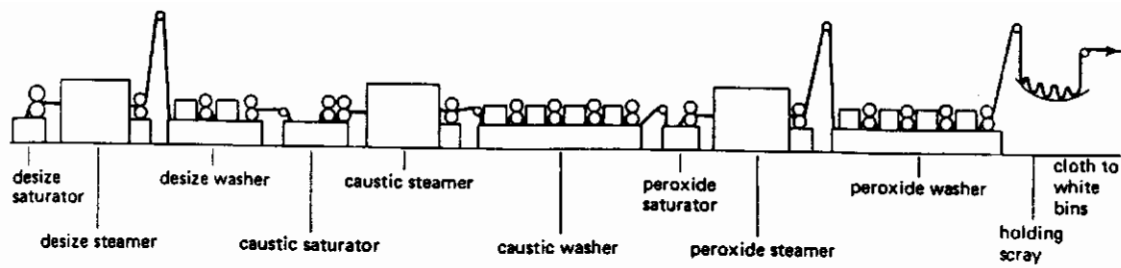

### a. Applicators - Pads

Chemicals are applied by padding. Pad designs will be discussed later in the section on finishing.

### b. Steamers

Steamer provides dwell time, moisture and temperature. The drawing in figure 9 shows a combination roller section - conveyer-bed steamer. The impregnated fabric enters the roller section where the fabric is exposed to heat and moisture in open sheet form. It is then plaited onto a conveyer-bed to provide reaction time for the chemicals to work before the fabric is washed. Some steamers have only the roller section. These require more floor space if the dwell time is to be equivalent. The combined roller, conveyer bed steamers are the result of new developments aimed at improving cost/performance.



**Figure 9. Schematic of a Roller Bed Steamer**

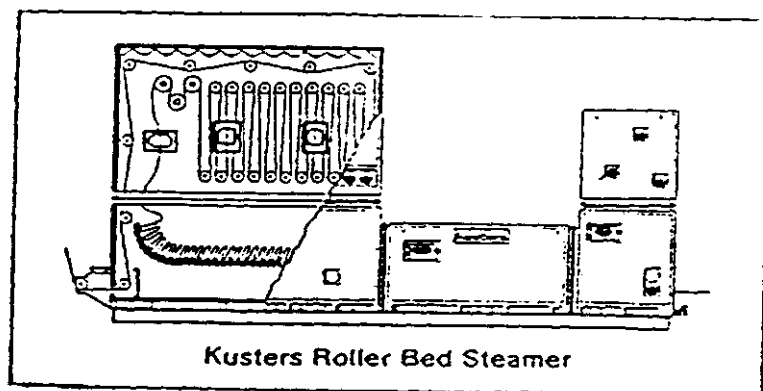

### **c. Open Width Washers**

An open width washer can be a simple box (figure 10) containing a series of vertically stacked rollers where the lower rollers are submerged in the wash water. Fabric enters the box at one end and traverses the box by going over and under each stack. Any number of these boxes can be arranged in series to provide the appropriate amount of rinsing. More sophisticated boxes will be divided into several compartments. Squeeze rolls are placed between them to speed up the removal of impurities. Some are equipped with spray nozzles which also facilitate the flushing action.

In another design, the rollers are stacked horizontally. The fabric enters through a trough at the bottom of the box. The thread-up is such that the fabric travels to the upper set of rollers and works its way down successive pairs of rollers until it reaches the bottom. There it exits through another trough. Water cascades downward through the layers so the flushing action is assisted by the physical force of the water impacting the fabric.

**Figure 10. Washers**

**Open Box Washer**

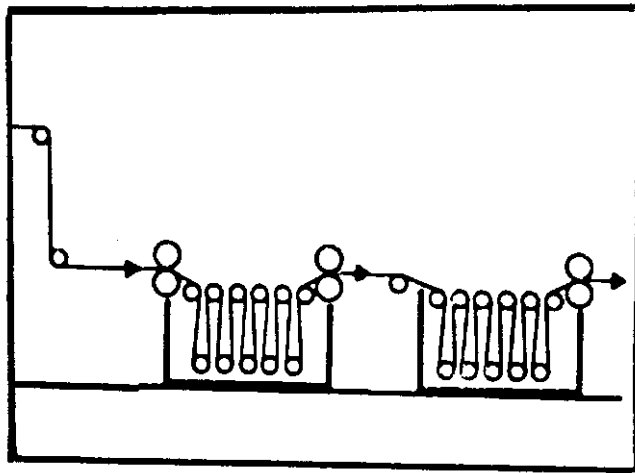

**Horizontal Washer**

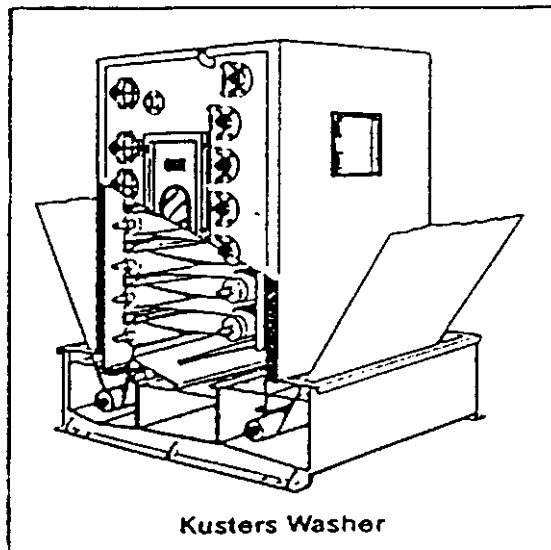

Since hot water is an expensive raw material and environmental pollution laws regulate discharge water, it is important to reduce the amount of water consumed by these operations. One way to reduce water consumption is by *Counterflow Washing*. Water flow through the wash boxes counter to the flow of the fabric. Fresh water is fed to the exit compartment to insure that the fabric exits through the cleanest water. The water from the last box is pumped to the preceding wash box which in turn is pumped to the one preceding it. The water from the entry box is dumped into the drain since it is the most heavily contaminated wash water. This technique saves on water consumption since only the most heavily contaminated water is discharged, cleaner water is reused until it becomes heavily contaminated.

### **III. REFERENCES**