

# PRE-DYEING TREATMENTS

The pre-dyeing stage includes a series of operations that prepare the textile product for subsequent finishing treatments such as dyeing, printing and finishing.

These operations vary according to the type of fibre on which they have to be carried out, to the structure of the textile product (staple, top, sliver, yarn, fabric) and also depend on the subsequent treatments to be carried out, which may change according to various factors such as market demands, customer requirements, staff experience, and availability of machines.

The pre-dyeing stage includes for example **desizing, singeing, mercerising, scouring, and bleaching**. Each process varies according to the processing conditions and the above-mentioned specific situations.

Some of these processes (for example bleaching and mercerising) can be considered either preliminary operations or finishing treatments; this depends on the type of the downstream processes to be carried out on yarns or fabrics.

## Singeing

With this treatment fuzz and fibre ends are burnt off in order highlight the fabric weave.

It is generally carried out on gray pieces and the residues are removed by a further washing process. An oxidising flame, which does not leave any trace of sooty residue on fibres, is used to carry out this operation.

The flame can be perpendicular to the fabric, and only rarely tangential; the fabric is positioned at a distance of 1.5 - 4 mm from the end of the flame and the machine is equipped with a suction device under the fabric, which attracts the flame and concentrates the heat on the fabric. The fabric speed can range from 60 to 120 metres per minute.

The singeing process with *perpendicular* flame is the most common one, while the process with *tangential* flame is used for fine fabrics (light singeing).

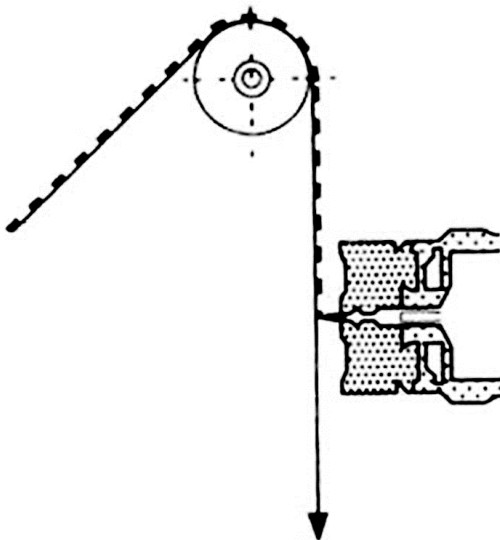

Picture 1 - Fabric singeing with perpendicular flame

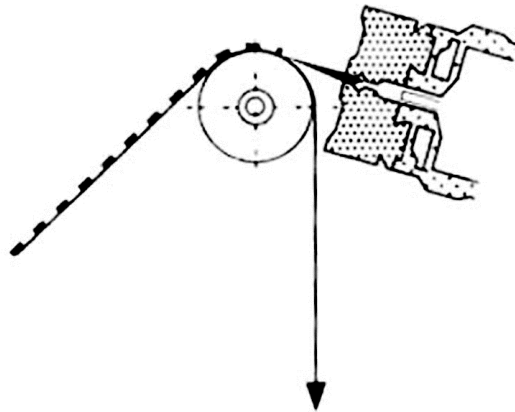

Picture 2 - Fabric singeing with tangential flame

Singeing is carried out rarely on knitted fabrics and frequently on yarns and woven fabrics. Instead of the traditional singeing process, it is possible to apply an enzymatic treatment (for cotton and lyocell fabrics), for example with cellulase, which uses chemical agents to corrode the fibre surface and remove the fuzz from the fabric.

## **Desizing**

This treatment is carried out on woven fabrics to remove the sizing substance from the warp. The size must be totally eliminated since the fabric must absorb the liquor of subsequent processes homogeneously.

Since amylaceous sizes are generally used for cotton yarns, it is possible to apply amylolytic enzymes (*enzymatic desizing*), which carry out a biological degradation process of the starch, transforming it into soluble by-products which can be then eliminated by washing. The enzymatic process depends on the quantity of enzyme molecules per gram of fabric, while the thermal stability of the enzyme depends on the bacteria strain from which it originates. The amylases only react with starch molecules and do not affect the other glucose polymer (cellulose), since they attack the 1.4 alpha-glucoside bond of starch and not the 1.4 beta-glucoside bond of cellulose.

This reaction makes the use of amylases profitable (when applying starchy sizes) compared to other desizing agents such as alkali and oxidising agents (*oxidising desizing*), which attack both starch and cellulose.

The oxidising desizing process is used to remove non-starchy sizes that do not dissolve in water or to eliminate starchy sizes combined with polyvinyl alcohol (this treatment is carried out before the singeing process).

This last treatment requires accurately controlled operating conditions to solubilise only sizes and avoid any possible fibre degradation. Enzymatic desizing can be carried out in discontinuous systems (*jigger*) but semi-continuous or continuous techniques are more frequent after the pad-batch wetting of the fabric. The most frequently used processes are *pad-roll* and *pad-steam*.

If the size is water-soluble, it can be eliminated by hot washing.

## Scouring

On cotton fibres, this treatment removes fatty and pectic substances, softening moles and preparing the material to absorb the subsequent treatment agents.

Scouring is usually carried out in soft water additivated with textile auxiliaries such as absorbing agents, detergents, emulsifying agents, caustic soda and/or Solvay lye and sequestering agents.

Alkali make the fibre swell and enhance the action of surfactants. This treatment can be carried out on filaments, yarns and fabrics.

Instead of the traditional scouring process, it is also possible to carry out an enzymatic scouring process (bioscouring) to remove non-cellulosic material from cotton fibres, to make them more easily wettable and enhance the subsequent absorption of finishing liquors.

The scouring of pure silk is a degumming process used to remove sericin (silk gum) from fibroin floss. Sericin is the gummy element which keeps together the fibroin floss and gives the silk a hard hand and dull appearance. It is carried out on yarn, on dyed yarn, piece-dyed fabric or on products ready for printing. The treatment, which causes a loss of weight ranging between 24 and 28%, gives the degummed silk a lustrous appearance and a soft hand; the treatment is carried out with soapy solutions or with buffer dissolving agents. It is also possible to use enzymes (protease), which hydrolyses sericin. Recently, a treatment with H<sub>2</sub>O at 120°C has also been successfully applied especially on yarns.

On wool, the scouring process removes oils and contaminants accumulated during upstream processing steps and can be carried out on slivers, yarns and fabrics with solutions containing sodium carbonate with soap or ammonia, or anionic and non-ionic surfactants, which carry out a softer washing to avoid any damage to the fibres.

The scouring process applied to synthetic fibres removes oils, lubricants and anti-static substances, dust, contaminants and can be carried out on yarns and fabrics (when warp yarns have been bonded, the treatment is called debonding). It is carried out by means of surfactants, detergents and emulsifying agents.

Scouring is usually carried out by means of continuous or discontinuous systems, with the same machines used for downstream treatments; temperature, processing time, pH, concentration of reagents, depend on the fibre and on the machine used.

Incomplete scouring processes usually originate dyeing and printing defects due to different degrees of wettability and to inconsistent affinity for dyes of the material.

## Bleaching

Bleaching treatments are applied to eliminate any impurity and obtain a pure white tone, to prepare substrates for low-density dyes or prints and to level off undesired tone variations.

Bleaching agents mainly used for cellulosic fibres are *sodium hypochlorite* and *hydrogen peroxide*. They both require the addition of sodium hydroxide in the bleaching liquor to make it alkaline it by favouring the formation of the bleaching ion, which in the first case is the hypochlorite ion and in the second one is the perhydroxyl ion.

When using hypochlorite the pH must range between 9 and 11 and the temperature must not exceed 30° C. In fact, as far as the pH is concerned, pH values below 4 give rise to the formation of chlorine while pH values ranging between 4 and 9 give rise to the formation of hypochlorous acid: these chemical substances affect the fibre negatively and do not perform a bleaching action. After the bleaching with hypochlorite it is necessary to carry out an antichlor treatment. Fibres must be treated with hydrogen peroxide, which completely removes the chlorine and avoids the formation of chloramines, which, in drying machines, could generate HCl dangerous for cellulose.

With hydrogen peroxide, in the presence of alkali, little moles can be eliminated and the autoclave scouring can therefore be avoided.

The optimum temperature ranges between 80° and 90° C and the pH between 10.7 and 10.9. Hydrogen peroxide at a concentration of 1-2 vol can be used also for silk after degumming, with a pH of 8 –9, at 70-80° C for 1-2 hours.

On wool, it is possible to improve whiteness with a bleaching process using hydrogen peroxide, with a vol. range of 1 to 3, stabilised with pyrophosphate with a pH value between 8 and 9, at a temperature of 45-50° C for a time which can vary from 30 minutes to 3-4 hours. In alternative, it is possible to carry out a treatment with a pH value of 3-4, in acid environment for HCOOH at ambient temperature; in this case, the formic acid reacts with peroxide, generating performic acid, which carries out the bleaching action. This method slightly damages the wool but gives good results.

From an environmental point of view, hydrogen peroxide is more suitable than hypochlorite since it has a lower impact on the environment and effluents can be decontaminated with simpler operations.

It is recommended to add sequestering agents to the bleaching liquors.

Another bleaching agent used in textile processing is sodium chloride (suitable for synthetic fibres) that takes advantage of the oxidising action of chlorine dioxide generated as a result of the hot acidification of the solution of this salt. Unfortunately, chlorine dioxide is a toxic substance and attacks stainless steels; therefore it is necessary to work in hermetically closed units equipped with suction systems with resistant materials such as stoneware.

Bleaching operations can be carried out on yarns, fabrics and knitting with continuous and discontinuous process in circulating liquor machines (*autoclaves, jigger, paddle wheel, jet, overflow*), semi-continuous (*pad-batch, pad-roll*).

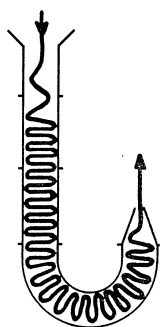

Picture 3 – A J-box

Continuous bleaching can be carried out on knitted fabrics using a J-box (Picture 3). The products to be used on the fabric are applied by means of suitably positioned mangles; the fabric is introduced in the machine where it remains for the time necessary to complete the bleaching process.

Temperature, speed, pressure and pH are controlled automatically.

It is also possible to carry out optical bleaching using substances that do not perform a chemical action on the fibre but obtain a whitening effect by means of an optical compensation process of physical nature. These substances release a blue light compensating white and grey, and giving a dazzling white effect. For example an optical bleaching on wool can be carried out after chemical bleaching, using 0,2-0,6 g/l optical bleaching agent at pH 4-5 for acetic acid, at a temperature of 50-60 ° C for 30 minutes.

## Mercerising

This is a typical treatment for cotton yarns and fabrics, which improves the fabric luster and wettability, ensures a covering effect for dead cotton, improves dimensional stability and dyeing efficiency.

This treatment is carried out using caustic soda (28 - 30° Bé), which determines the contraction and swelling of the fibres; they become translucent and increase their tensile strength, but reduce their flexural and torsion strength. The bean-like section of the fibre becomes first elliptic and then circular, allowing a better reflection of light with a consequent increase of luster.

The treatment is usually carried out under tension, with caustic soda at 28°- 30° Bé (approx. 270- 330 g/l).

If the concentration is lower than 24° Bé, the treatment is called *causticization* and aims at enhancing the dyeing liquor penetration into the fabric.

The liquor temperature usually ranges between 15-20° C and its uniform absorption is assured by adding mercerising wetting agents stable in alkaline environment. Once the operation has been carried out, alkalinity must immediately be neutralised by means of a diluted acid solution.

From a chemical point of view, alkalicellulose is the first material to form; the next material, which forms after repeatedly water washing is hydrocellulose, which is more reactive than natural cellulose.

Cotton wetting entails shrinkage of the material, which must be kept under tension, to avoid a fuzzy and woollen appearance.

Mercerising is carried out on yarns, fabrics or open or tubular knits.

As far as yarns are concerned, before the mercerising process in special machines, they undergo a singeing treatment to remove the fuzz and end fibres – which could otherwise prevent the perfect reflection of light after mercerising. There are two different types of machines to be used for woven fabrics: a chain system and a cylinder system.

*Chain mercerising*: with the chain mercerising process the fibres achieve perfect brightness thanks to optimum tension control. This system runs slowly and allows no flexibility when the width of the fabric varies.

*Cylinder mercerising*: this is a more compact and faster system compared to the previous one; cylinder mercerising does not allow the contraction of the warp because the fabric is drawn in on the cylinders.

The contraction of the filling yarns is also prevented thanks to the tension produced by the simultaneous action of the cylinders and of the fabric wetting. Cylinder mercerising machines are also used for flat knits.

Mercerising process can also be carried out on tubular knitted goods: after the wetting process, the fabric is left reacting in a padding mangle. The withdrawal of the fabric width is controlled by means of an adjustable ring spreader while the withdrawal of the fabric length is controlled by “slowing down” the fabric before the final squeezing. The sodium hydroxide concentration is brought down to approximately 4 ° Bé by means of a circular shower. The fabric is then washed, neutralised and rinsed.

Another well-proven mercerising agent is liquid ammonia, which has to be applied for very short times (about half a second). There are very few systems based on liquid ammonia due to the difficulties connected to the use of liquid NH<sub>3</sub> (toxicity, formation of blends that can explode in presence of air and very strict regulations concerning the welding of steel sheets used to build these systems that operate at very high pressures since the boiling point of ammonia is usually -33°C).

Engineers have recently developed continuous mercerising cycles and machines for combined mercerising and bleaching process.

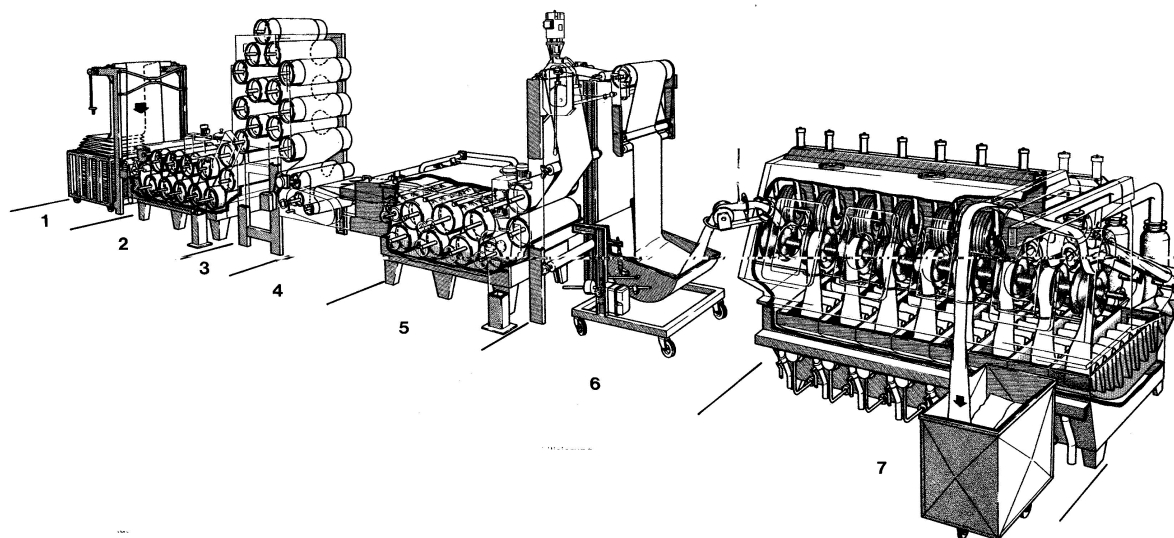

*Picture 4 - Continuous mercerising and bleaching system for tubular knitted fabrics*  
1. entry 2. wetting with NaOH 3. exposing 4. spreader 5. stabiliser 6. exit 7. neutralisation and bleaching

## Chlorination

This specific treatment applied to wool enhances its dimensional stability to shrinking; it can also be used as finishing or preparation process before dyeing or printing. Thanks to the reduction of the cuticle thickness, with the consequent disappearing of scales (which are rounded off and made thinner), wool loses its felting capacity and therefore minimises shrinkage (dimensional stability). The result is that a chlorinated wool garment can undergo repeated machine washing cycles (delicate cycle).

The process can be carried out at any stage of the fibre processing; chlorinated wool is particularly lustrous and has higher affinity for dyes.

From an operational point of view, the best results can be obtained with the combination of two different and complementary treatments: the first one is an oxidising treatment followed by a special treatment with cationic resins.

The first treatment is the traditional chlorination process, carried out using:

- NaClO in presence of strong inorganic acids (sulphuric acid)
- Cl<sub>2</sub> gas
- Chlorine organic salts (sodium salt of dichloroisocyanuric acid) which, in acid solution, releases chlorine.

The second treatment is carried out by applying special resins enhancing the anti-felting effect (PA – epichlorohydrin or cationic resins polysiloxanes).

An antichlor treatment with NaHSO<sub>3</sub> must be carried out subsequently to eliminate any residue of Cl<sub>2</sub> that might remain on fibres.

New treatments to be carried out on tops or fabrics (plasma treatment) are now being studied as an alternative to chlorination.

Process and systems used: circulating liquor units are used for tops; autoclaves are preferred for yarn packages and overflow systems are used for woven or knit fabrics.

## Carbonising

In the worsted wool cycle, the foreign matter (mainly of cellulosic origin) included in long-fibre wool is removed almost completely by the combing machine. The combed sliver contains very small quantities of foreign particles, which do not affect the subsequent treatments, and above all the dyeing process.

A different approach must be however applied in the woollen cycle, where the quantity of contaminants requires a specific treatment with sulphuric acid, to avoid any possible problems during the dyeing process.

Carbonising is also essential when the raw stock is mainly composed of rags or waste (dry carbonising with HCl gas at 80°C). In fact, with this type of material the carbonising process eliminates any vegetal residue in the staple after scouring, due to the good resistance of wool to the action of acids which, on the contrary, destroy cellulose, and to the strong dehydrating action of the acid which provokes a weight loss that cannot be exactly evaluated in advance.

Carbonising can be carried out also on staple fibres, yarns and fabrics. Washed and sometimes piece-dyed fabrics as well as gray fabrics can also be carbonised.

The operating conditions necessary for the carbonising process are the following: the fibres are soaked with H<sub>2</sub>SO<sub>4</sub> (2,5 – 4 ° Bé or 4 – 6 %), squeezed by means of two cylinders and then dried in a stenter at 85 – 90°C, for 30 – 60 minutes.

Hot air concentrates the acid by evaporation, as a result dehydrating and hydrolysing the cellulosic matter.

Finally fibres are carefully washed to remove completely any residual acidity, which could affect the fibre and subsequent operations. A series of washing processes also includes a neutralisation treatment with sodium acetate.

During the fabric process, a dry beating process to remove the carbonised vegetal residues from the fabric texture precedes the washing phase.

Process and systems used: wetting vessels, squeezing cylinders, stenter, dry fulling unit.

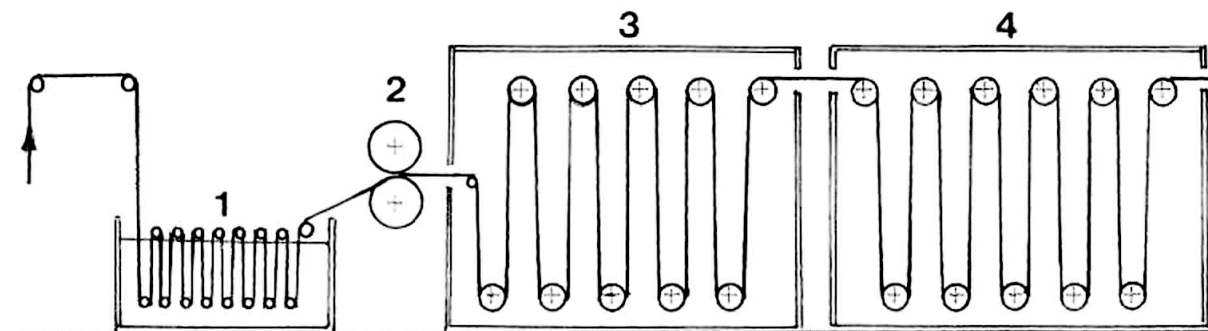

*Picture - 6 Traditional carbonising process for fabrics*

- 1) wetting vessel; 2) squeezing unit;*
- 3) drying unit; 4) carbonising unit.*

### *Solvent/water combined process*

This process bases its efficacy on the fact that perchloroethylene, thanks to its low surface tension, can soak textile fibres deeper and faster than an aqueous solution.

On the contrary, since vegetal impurities contained in the fabric are highly hydrophilic, their affinity for the solvent is lower than the fabric's; the solvent is contained only in the surface of vegetal particles. When the fabric soaked with solvent comes in contact with an aqueous solution of sulphuric acid, the aqueous solution cannot remove the solvent from the wool and replace it. On the contrary, the aqueous solution is absorbed by vegetal hydrophilic particles. In practice, with this system vegetal impurities absorb the acid solution selectively, and the acid carries out only a gentle action on wool.

The benefits of this process are lower pollution, considerable reduction of damage to the wool and the possibility of by-passing the acid removal step (or if necessary, this step is considerably easier and faster).

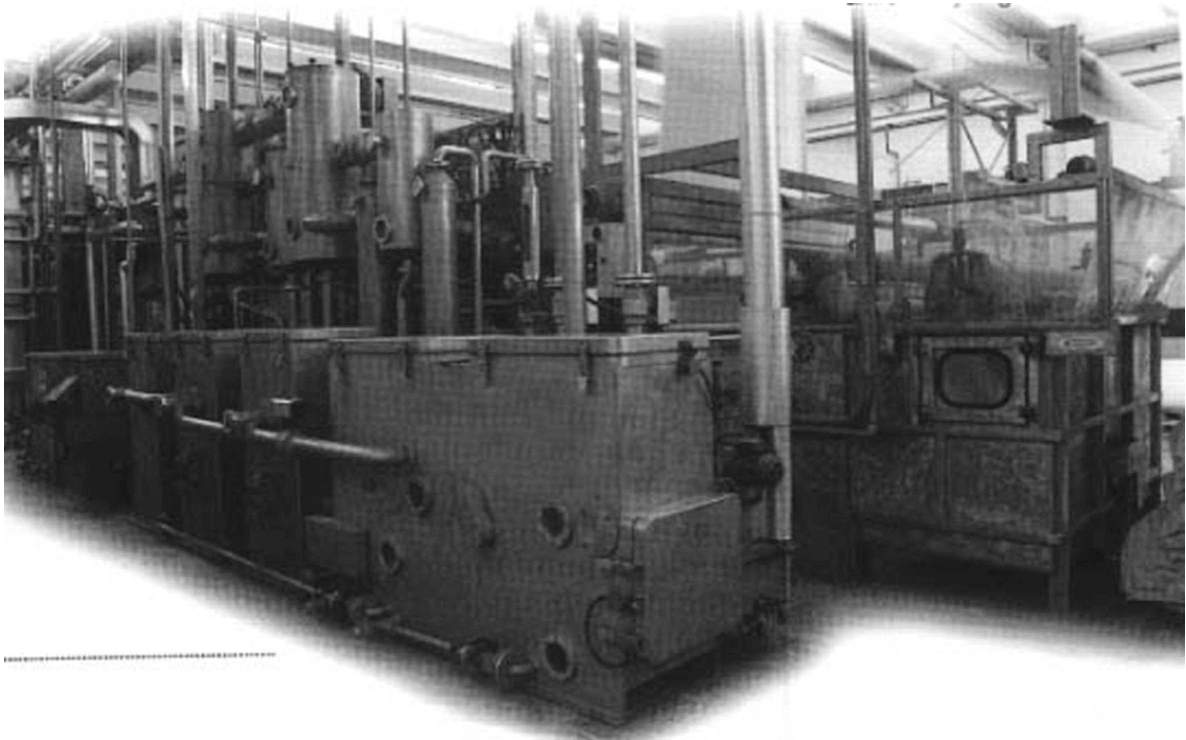
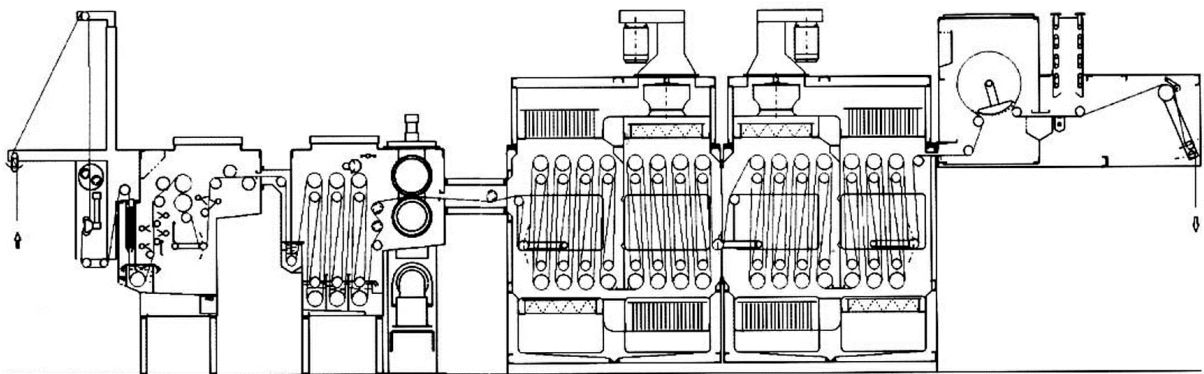

*Picture 7-8 - Diagram and picture of a solvent carbonising plant*



## Oiling

The oiling process aims at minimising resistance during the various operations that transform staple into yarn and then yarn into fabric.

Operating conditions: staple is sprayed with oil emulsions in water stabilised with surfactants (favouring the subsequent elimination).

## Fulling and Washing-milling Treatments

During the traditional milling operation, fabrics of combed, carded or blended wool (non-scoured, scoured or carbonised and neutralised), at about 40°C, are soaked and in presence of special surfactants, are subjected to continuous pressure both in weft and warp direction. Under these conditions, wool fibres tend to felt, thus causing fabric shrinkage and a subsequent dynamic compacting. After this operation, the material must be washed to remove dirty water and the chemicals used.

Temperature and mechanic stress must be carefully controlled during all the processing steps; the operation is completed when the desired shrinkage degree has been obtained. Obviously, it is necessary to avoid rope wrinkling or irregular shrinkage on the fabric.

When the process is carried out with older fulling units, before loading, the ropes are sewn in a tubular structure to favour the wrinkle movement, and avoid irregular tensions on both selvages; in the process, an air pocket forms inside the “cylinder” of wet material thus favouring the wrinkle movement. The percentage shrinkage in warp direction (lengthwise) is controlled from the beginning by means of markers positioned on the centre of the piece in warp direction, at one-metre distance.

In newly designed machines the fabric milling process is often combined with a washing process (sometimes milling is combined with a quick washing process).

Here are some components which usually make up a milling machine:

Jaws: vertical parallel steel plates, positioned in the front part of the machine that make the fabric shrink in the weft direction by squeezing the fabric.

Pressure cylinders: adjustable-pressure cylinders that make the fabric shrink in the weft direction and push the fabric inside the box.

Box: square section tube where the fabric is packed, slowed down by means of the adjustable plate. In this section the fabric shrinks in warp direction.

Plate: hinged plate on top of the box; it can be lowered by reducing progressively its section, slowing down the fabric.

Washing-milling machines also include:

Squeezing cylinders: to favour the change of the washing liquor.

Vessel: placed below the squeezing cylinders to collect polluted water and drain it. When the vessel is open, water is poured directly into the liquor.

Many machine manufacturers have studied custom-made solutions to enhance the milling and/or washing effect or to increase the machine flexibility and improve its output capacity. These machines can generally process fabrics whose weight ranges between 80 and 800-1200 g/metre.

The following examples show some of these solutions:

*Milling step:* the air jets move the wrinkles of the incoming rope (some machines can also do the same on the delivery side); the plate is lowered and the jaws are closed. Machines with this particular structure can run at a maximum speed of 250-300 m/min (Picture 9).

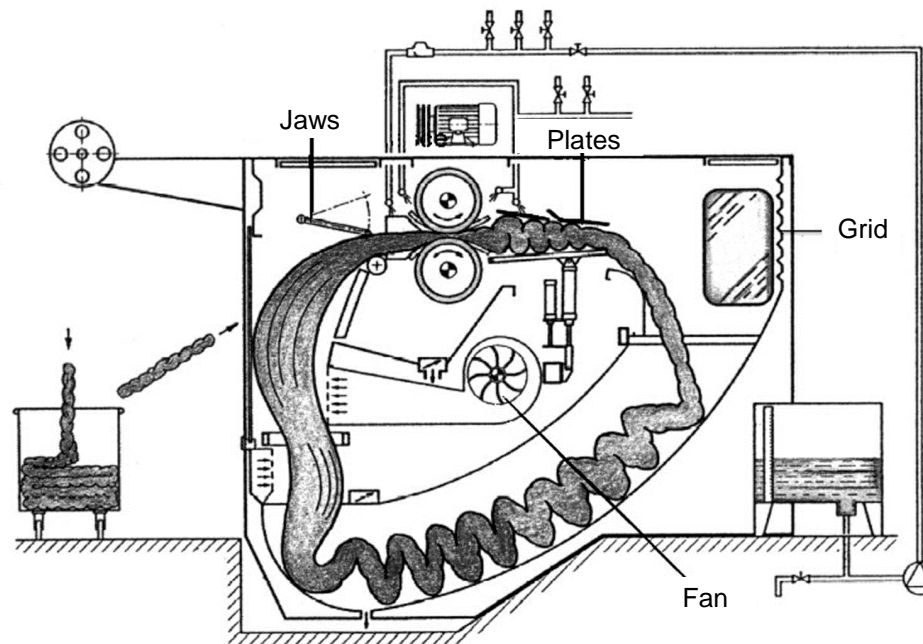

*Pictures 9/14 – Schemes of milling machines showing the different operating steps*

*Gentle washing step:* the air jets move the rope wrinkles; the plate is lifted up while the liquor is uninterruptedly fed on the fabric. This type of machine can run at a maximum speed of 200-220 m/min. (Picture 10).

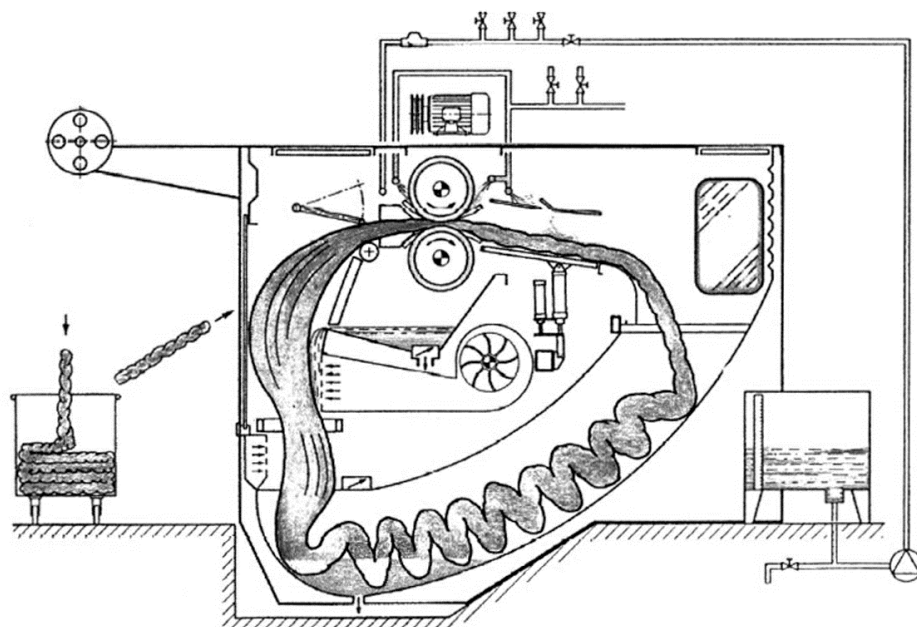

*Picture 10*

*Fast washing step:* the air jets can remain open. The fabric, drenched with liquor, moves at a speed ranging between 400 and 600 m/min. with the plate open, and runs into the grid. Beating, combined with high speed, causes a slight felting on the surface and the yarn swells, as a result hiding the comb marks (Picture 11).

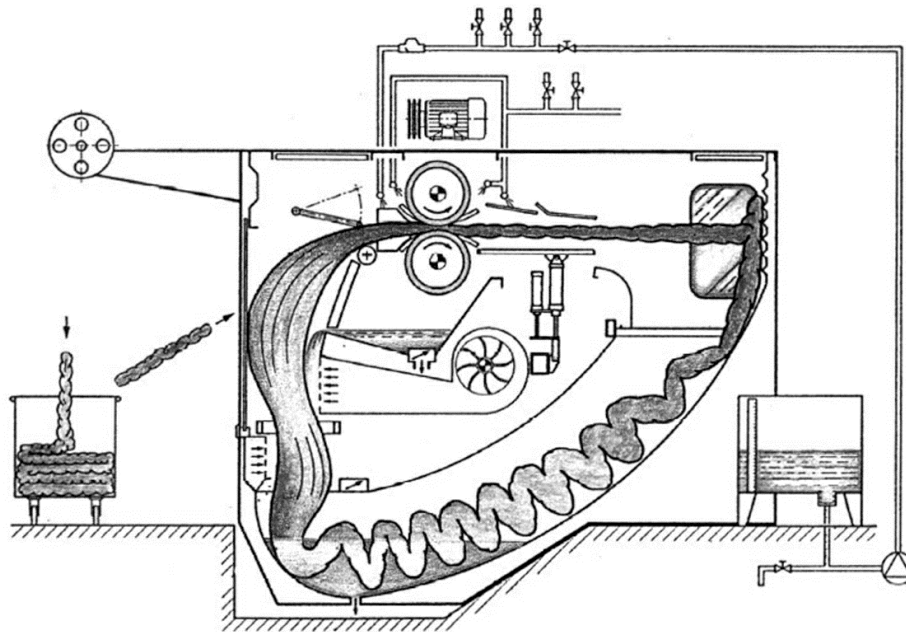

Picture 11

Alternatively, the fabric can be taken up by a toothed cylinder helped by the lower part of the plate, thus increasing the milling effect (Picture 12).

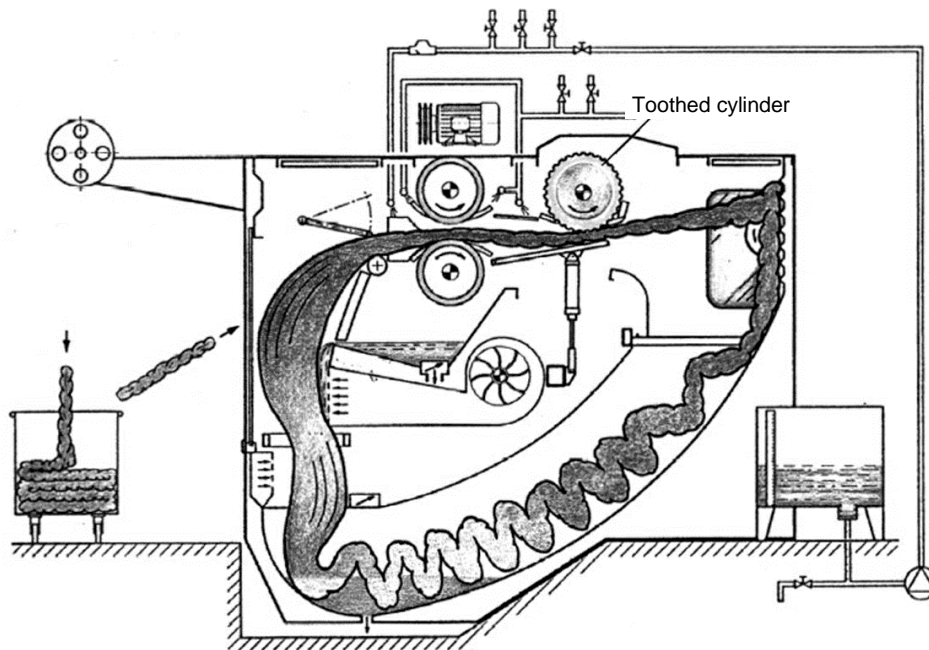

Picture 12

Some machine manufacturers have adopted two upper cylinders for feeding the fabric, with a lower rubber cylinder with a rough surface (Picture 13).

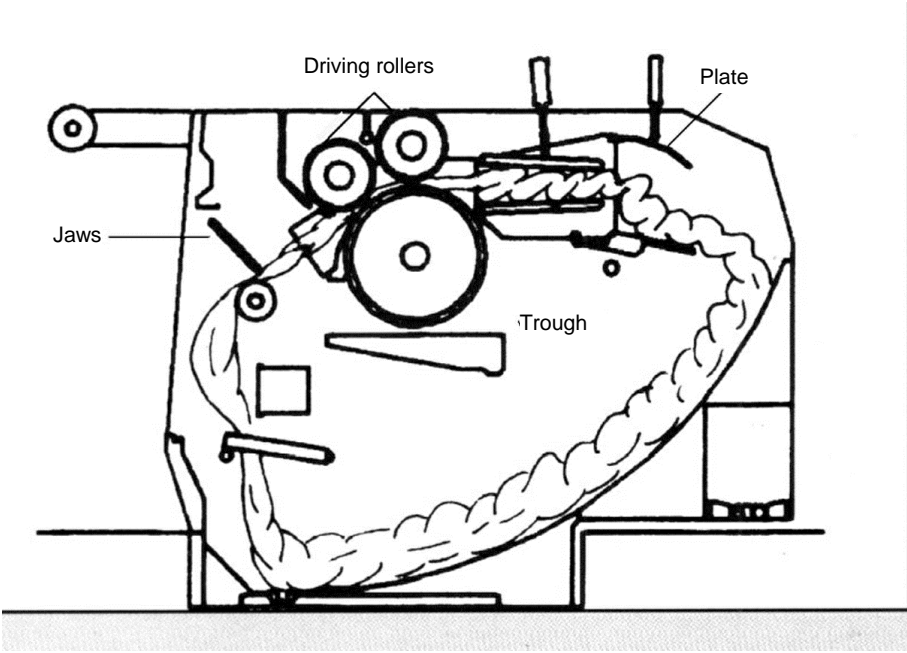

Picture 13

*Split-flow milling and washing step:* on some machines it is possible to carry out one or two treatments on fabrics of different weight.

The shrinkage of each fabric cloth and the machine settings can be selectively and individually controlled. In these machines, the fabric is exposed to powerful air jets while falling down from the milling box; this changes continuously the rope position.

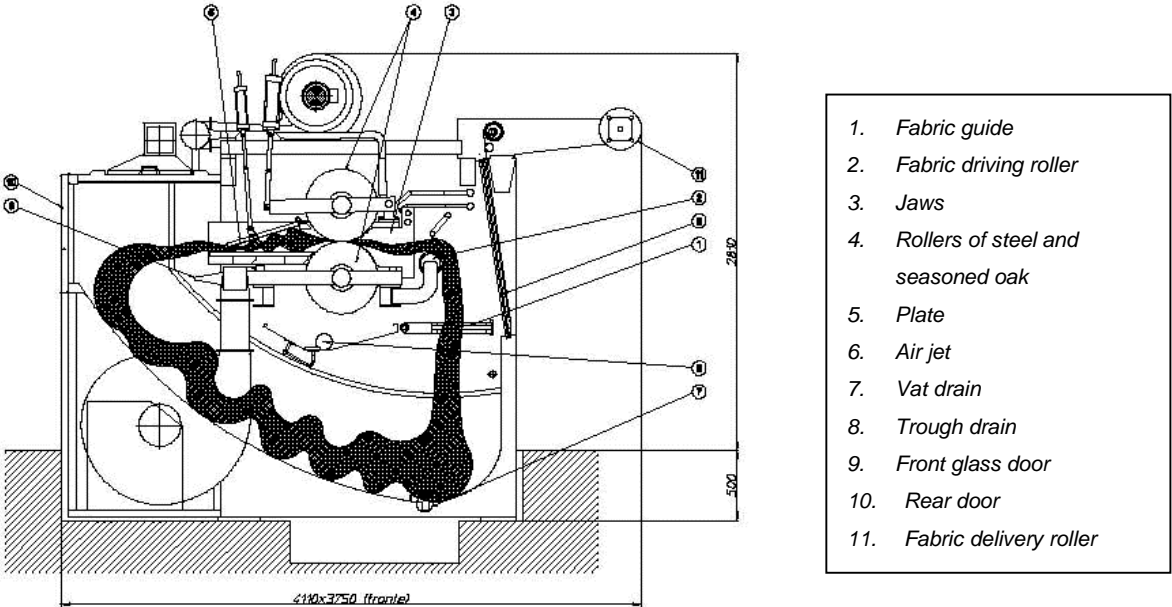

Picture 14

On these machines too, the expertise of machine manufacturers and the application of the latest electronics have allowed the introduction of some devices that increase the output capacity and permit more accurate controls, ensuring excellent repeatability.

Some of these new devices are for example fabric-skid control devices; independent split-duct milling machines that allow to process different fabrics in different conditions with consequently different results; non-stop seam position detector for each separated duct, with individual stop of each single rope; front positioning of the seams of all ropes when the machine stops.

## Silk Weighting

The weighting process is carried out to increase the silk weight, providing fuller hand, more luster and bulk, and making the fibre suitable for the manufacturing of fabrics to be used, for example, for ties. The weight increase is expressed as percentage weighting above or below the parity. Parity weighting means that the fibre regains the original weight it had before the degumming process:

$$\text{Percentage weighting} = (\text{weight after weighting} - \text{raw weight}) \times 100 / \text{raw weight}.$$

There are many types of weighting; till some years ago, a few mills still carried out mineral weighting, but now this process has been abandoned definitively. Today, the most frequently applied type of weighting is synthetic weighting (or chemical linking).

### Synthetic weighting

Chemical principle for weighting with methacrylamide:

The monomer used for synthetic weighting is often derived from acrylic or methacrylic acid. The silk weighting with acrylonitrile and methymethacrylate has been studied and described thoroughly; in this process, starters are formed by a redox system based on iron salts ( $\text{Fe}^{++}$ ) and hydrogen peroxide, persulphates and other substances.

*The diagram shows the starting of synthetic weighting reaction by the formation of radicals*

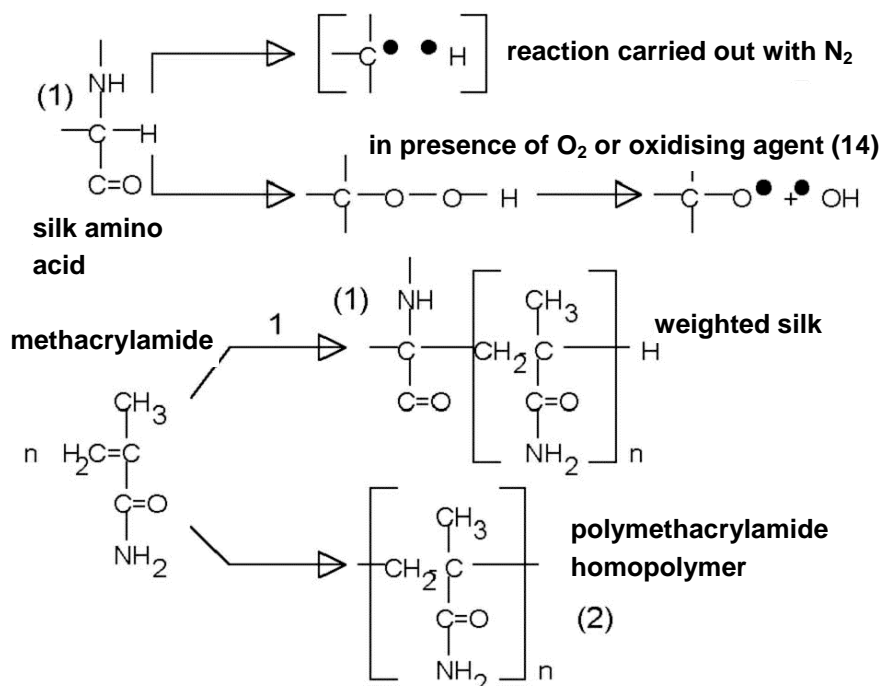

The weighting reaction can occur on the alpha carbon atom of the amino acids which make up fibroin (1), or on lateral chains, such as for example the methyl group of alanine.

In the meantime, we can have a competing weighting reaction with the methacrylamide homopolymerisation, as shown in diagram (2). Once formed, these homopolymers cause a significant hardening of silk and, even if not covalently bonded to the fibre, they cannot be eliminated with further and repeated washing.

Basically the real weighting process is carried out by means of a MAA (methacrylamide) based resin. Good swelling and a high-luster finish of the fibre can be obtained with this method but the quality of the hand achieved is poorer than the one obtained with mineral weighting and the affinity for dyes is of inferior quality, even if hand is usually harder, thanks to good fibre swelling. To achieve parity weighting it is necessary to use 50% of MAA calculated on the total fabric weight, 3.5% of ammonium persulphate (catalyst) calculated on the resin weight, 2 ml/l of formic acid and 0,2 g/l of nonionic surfactants. Starting from 40°C, the temperature must be brought to 80°C in 20 minutes, and kept at this level for 60 minutes. The temperature is then decreased to 60° and the liquor is drained; after a 10-minute washing with 2 g/l of soap at 80° C, the silk is finally rinsed.

Now, more and more frequently milling facilities tend to carry out weighting operations with different unsaturated monomers featuring different performance and used in limited quantities; these unsaturated monomers work according to the same weighting principle, but give silk unique effects and distinctive characteristics of dimensional stability and crease-proof properties. We indicate below some examples of monomers and catalysts used:

*Vinyl monomers used for copolymer weighting of silk fibres*

Vinyl monomer	Formula	Starter
-Methyl methacrylate (MMA)	$CH_2=C(CH_3)CO_2CH_3$	1-KPS, APS 2-TBB 3-Syst. metal redox 4-Syst. non-metal redox 5-Syst. complex transf. 6-Irradiation
-Methacrylamide (MMA)	$CH_2=C(CH_3)CONH_2$	1-KPS, APS 6-Irradiation
-Styrene (St)-2-Hydroxy ethyl -methacrylate (HEMA)	$CH_2=CH-C_6H_5$ $CH_2=C(CH_3)CO_2CH_2CH_2OH$	1-KPS 1-APS
-Methacrylonitrile (MAN)	$CH_2=C(CH_2)CN$	1-NaPS
-N(n-Butoxymethyl)- Methacrylamide (nBMAA)	$CH_2=C(CH_3)CONH(CH_2OC_4H_9)$	1-APS
-Ethoxyethyl-Methacrylate (ETMA)	$CH_2=C(CH_3)CO_2CH_2CH_2OC_2H_5$	1-APS
-Acrylamide (AA)	$CH_2=CHCONH_2$	3-Syst. metal redox
-N,N'-Methylenbis acrylamide (N,N'-MBA)	$(CH_2=CHCONH)_2CH_2$	3-Syst. metal redox
-Ethyl Methacrylate (EMA)	$CH_2=C(CH_3)CO_2C_2H_5$	6-Irradiation
-Buthyl Methacrylate (BMA)	$CH_2=C(CH_3)CO_2C_4H_9$	6-Irradiation 1-KPS

- 1) KPS = potassium persulphate; APS = ammonium persulphate; NaPS sodium persulphate.
- 2) TBB = tri-n-butylborane.
- 3) Vanadium (V); Cerium (4); Chromium (VI); Thallium (III); Manganese (III)-oxalic acid; Complexes of manganese acetyl acetonate (III), V<sub>o</sub> (II), Co (III).
- 4) Hydrogen peroxide-sodium thiosulphate; Peroxidiphosphate-thiourea; potassium peroxidiphosphate; Bromate-thiourea; Potassium peroxidiphosphate-fructose; Permanganate-oxalic acid.
- 5) Lutidine-bromine; Isoquinoline-sulphur dioxide.
- 6) X Rays.

## Heat Setting

This operation is crucial for fabrics made of synthetic fibres (PE, PA, elastomers), for triacetate, and partly for PAC fibres (setting), since it grants excellent dimensional stabilisation and crease-proof properties, maintained till the fabric is exposed (by air blowing) to temperatures exceeding the heat setting one (after being treated with water at a temperature above the second order glass transition temperature, i.e. 80-85°C for acrylics).

Heat setting is carried out on gray fabrics (scarcely applied), on scoured fabrics (frequently applied) and on dyed fabrics (scarcely applied).

The process grants excellent dimensional stability and good crease-proof properties.

As far as operating conditions are concerned, the fabric must be treated in accurately controlled moisture and temperature conditions.

<b>Fibre</b>	<b>Min T. °C</b>	<b>Max. T. °C</b>	<b>Time (in seconds)</b>
Polyester (PE)	170	210	15-50
Polyamide PA 6.6	170	210	15-40
Polyamide PA 6	160	180	15-40
Triacetate	160	180	15-40
Acrylic (PAC)	160	180-200	15-40
Elastomers	170	180-200	15-40

Machines used: stenters.

Fluctuating temperatures inside the stenter cause a consistent variation of crystallinity in the fibre structure, which leads to different affinity for dyes.

The moisture in the fibre produces soft hand, but variable moisture percentages in the different fabric sections create the above mentioned defect (variable crystallinity).

Too low temperatures do not allow a good setting while too high temperatures and too long setting times cause yellowing (PA and elastic fibres), stiff hand (acrylics), and loss of elasticity (elastic fibres).

The presence of combustion gas (NO<sub>x</sub>) produces a yellowing of the elastomers.

The heat setting process carried out before scouring could fix the stains on the fabric or make the scouring process more difficult due to the modification of the lubricating products (cracking with emission of polluting gas).

Heat setting after dyeing could lead to the sublimation of disperse dyes (if not accurately selected).

## **Decortication** (only for polyester)

This treatment is aimed at providing a silky-smooth hand to polyester fabrics (till a few years ago this process was also used to obtain microfilaments by increasing the fibre fineness), a lustrous effect and an enhanced drapability. The best results can be obtained with fabrics produced with coarser yarns.

The open-width decortication process can be carried out on jiggers or beam dyeing machines; rope decortication is performed on jet or overflow systems (batch systems). Decortication is carried out after scouring and heat setting; it is better to carry out a heat setting treatment also after the decortication process.

Operating conditions applied: the process is carried out at a temperature varying from 90-95°C to 120-130 °C for 20-35 minutes, with 30-50 g/l of NaOH 36°Bé. Once the process has been completed, the fabric is washed and neutralised.

Processes and machines used: open-width process on jiggers or beam dyeing machines (batch systems) or special tensionless open-width continuous machines.

## **Elastic Fabrics**

For elastic fibres, treatments depend on the chemical composition, which can be extremely variable.

As far as the fabrics containing segmented polyurethane fibres are concerned, the suggested treatments to be carried out are the following:

- relaxation
- heat setting
- scouring
- bleaching/dyeing/printing
- finishing

*Relaxation:* before carrying out any further treatment, it is recommended to relax woven or knitted goods to obtain a uniform shrinkage and avoid stitch distortion or fabric deformation, creases or wrinkles. The fabric relaxation is a crucial step to allow good shrinkage and give excellent elasticity since the fabric width on looms is always bigger than the finished one (tensioned yarns on the loom).

Many techniques are used but here are some of the most frequently used ones: table steaming, steaming carried out at the entry of the stenter, scouring carried out with hot solvents, relaxation in hot water with tensionless scouring; these techniques give poorer stabilisation results and do not provide permanent crease resistance to textiles and fabrics.

*Heat setting:* this process is crucial to give the fabric an optimum dimensional stability. It is recommended to carry out a heat setting treatment before any further wet treatment in order to avoid the formation of possible creases and folds. An optimum heat setting requires a temperature ranging between 180°-200°C, which must be maintained constant for at least 45 minutes. An optimum heat setting also requires the use of an indirect-air heating stenter, allowing more uniform temperatures and no-gas conditions, which could lead to fibre yellowing. The fabric is weighed at the entry of the stenter and then subjected to steaming. Since the fabric shrinks during the heat setting treatment, the fabric width on the stenter must exceed the desired width by 5-10%. An excessive heat setting could decolorise the fabric while an insufficient heat setting will result in poor fabric stability.



*Scouring*: it is necessary to carefully consider the characteristics of the fibre combined with the polyurethane elastomer.

*Bleaching*: this treatment is carried out using sodium hydrosulphite; a suitable optical bleaching agent can also be added.

## **Washing**

Rinsing and washing are the operations carried out most frequently during a complete textile finishing cycle. They are almost always connected to key treatments and aimed at removing from the fabric insoluble matters, matters already in solution or an emulsion of other impurities. During the fabric preparation process, for example, washing is carried out after desizing, boiling and other bleaching and mercerising processes; in dyeing, the washing stage is necessary to complete the dyeing process itself or to eliminate the dyestuff which has not been fixed; during the printing stage, washing performs a finishing action. When using vat dyes or disperse dyes, the washing process aims at removing insoluble pigment substances from the fibre surface by means of wetting or dissolving agents.

This could therefore be considered a crucial treatment in the whole textile process, because of the frequent use and strong economic impact. Manufacturers increasingly focus their attention on reducing water consumption, which leads to subsequent energy and hot water saving as well as a reduction in wastewater. Together with traditional washing systems with vats equipped with "vertical cylinders" the market offers horizontal washing units, which reduce the liquor ratio and the energy and water consumption for each kilogram of washed material.

Washing includes a chemical-physical process, which removes the dirt from the substrate, and a series of physical operations aiming at improving the "feedback action".

The sequence of the various washing steps is the following:

- a. formation of the detergent liquor (transfer of matter + energy by mixing);
- b. reaching of the process temperature and wetting (transfer of the liquor to the material);
- c. separation of impurities and emulsification (transfer of matter from one step to the other);
- d. removal of the liquor from the fibre (transfer of macroscopic matter);
- e. drying (interstage transfer of heat and matter).

Often these steps occur simultaneously. The use of surfactants (detergents) during the washing stage is extremely important to speed up the wetting of the textile material, to facilitate the removal of dirt from the substrate, thus keeping the emulsion inside the liquor and preventing the particles laying down again on the fibre.

Crucial factors are water (which must be quite soft to avoid precipitation of Ca and Mg salts which could give a rough and coarse hand to the textile) and chemical products to be used (emulsifying agents, softening agents and surfactants).

### *Contaminants to be eliminated*

Obviously the use of detergents, as well as operating conditions, depends on the nature of the chemical substances to be eliminated, which need to be generally classified.

A general classification is shown here below:

- 1) spinning oils. We must distinguish between fabrics made with yarns spun from combed or carded fibres, which are extremely different in terms of quantity (5 and 1 % respectively) and the nature of the substances added: as far as nature is concerned, the substances most frequently used are in both cases synthetic or mineral oils. These oils are usually made self-emulsifiable by means of suitable additives (materials must always be accurately evaluated since a wide range of products and prices are now available on the market); olein can be used for woollens (oleic acid) while for worsteds a good alternative can be represented by vegetal oils;
- 2) Sizes. For treating wool (opposite to cotton, where it is possible to use finish, which requires a special treatment), the stuffs now used (carboxymethyl cellulose or polyvinyl alcohol) can be easily eliminated and do not give particular problems;
- 3) oily stains. It is very difficult to eliminate these types of stain due to their characteristics and to their deep degree of penetration in the fabric; oily stains usually require a pretreatment with solvents sprayed directly on the stain (by means of a special "spray gun"). They can also be removed using special expensive detergents containing solvents, or by means of dry washing;
- 4) solid residues of various nature (dust, non-fixed dyestuffs, etc.), usually fixed on the fabric by means of fatty substances. To eliminate these residues, general cleansing rules must be observed and applied and special attention must be given to the mechanical action of friction.

It is worth specifying that the above mentioned discussion is not at all exhaustive; in particular, it is not a text relating to the treatment and elimination of severe stains (colors, metals, microbiological attacks, etc.), which cannot be treated with standard cleansing processes. Readers are recommended to consult the specific literature available on this subject.

## Washing machines

The scheme below shows all the categories of machines now in use; washing-milling machines are not included (combined washing and milling machines):

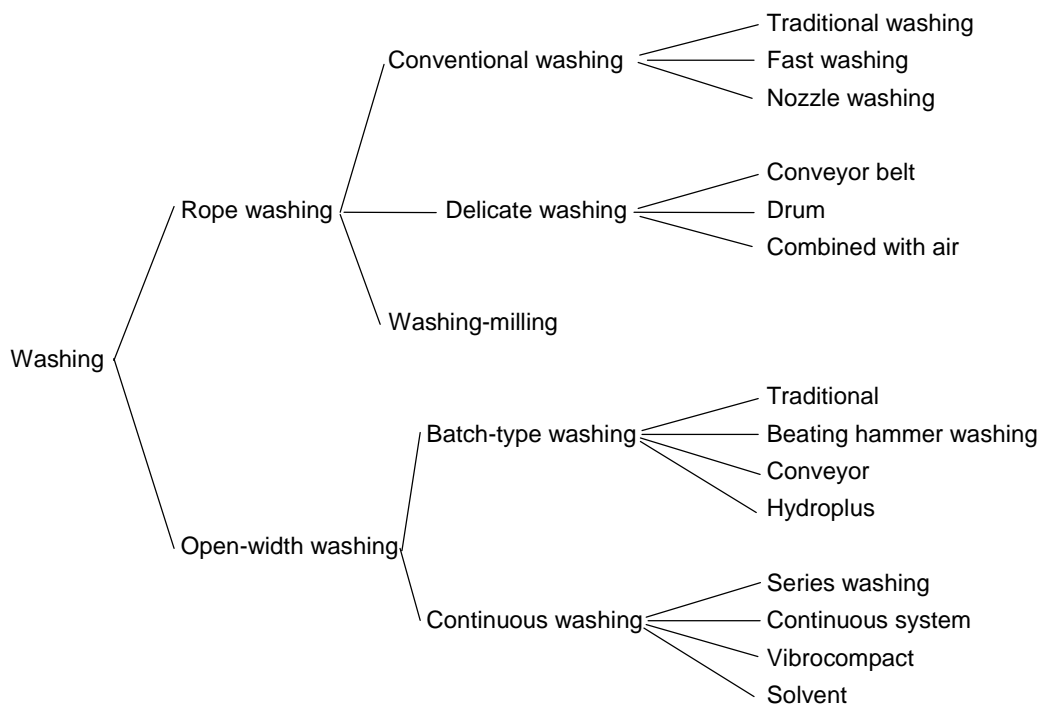

Washing can be performed on fabrics either in *open-width* or in *rope* form. Rope washing is more effective than open-width washing thanks to a stronger mechanic action, which favors the cleansing, and the relaxation of the fabric structure; for delicate fabrics an open-width washing must be preferred to avoid marks and creases. Open-width washing is also the best choice for processing huge lots.

### Rope washing

Substantially, batch piece washing machines are made up of a couple of squeezing cylinders, which make the fabric swell (the fabric is previously sewn on top and bottom and takes the shape of a continuous ring); these cylinders are assembled inside a vessel, whose lower part contains the detergent liquor. It is possible to wash a fabric inside this vessel, by feeding it into restricted area without laying it stretched out. The efficiency of this operation is enhanced by the mechanic action, which facilitates both detergency and tension relaxation. This operation is highly cost-efficient because open-width washing allows only one working position and therefore only limited loads can be processed (max. 180 kg) while a rope washing machine can include from one to eight ropes, with an overall weight exceeding 600 kg. Furthermore rope washing machines grant reduced operating times thanks to a more effective mechanic action.

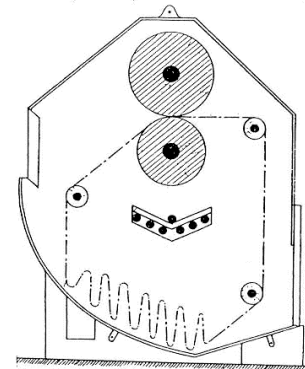

Picture 15 - Rope washing machine

### Open-width washing

An open-width washing machine is usually a system featuring a vertical path washing with driven cycle of multiple action baths, with a resulting 30/40% water and steam saving. This operating unit is manufactured in several versions (10-15-30 meters) and can be used for every kind of preparation and finishing treatment. Four different washing actions alternate inside this machine:

- 1) washing on rising paths;
- 2) washing on sloping-down paths, carried out by means of spray nozzles, which atomise on both face and back of fabrics, performing a strong penetration action;
- 3) "vibraplus" effect washing, which removes from the fabric the threadlike elements (fibrils) that do not dissolve in water;
- 4) extraction washing by means of vessel intermediate squeezing.

The longitudinal tension of the fabric remains perfectly unchanged on the whole path; it can be adjusted between 5 and 20 kg by means of upper cylinders equipped with self-adjusting control system which generates a sliding motion crease-and-fold proof also on extremely delicate fabrics. Plush fibrils are removed from the vessel with no need for brushes or liquor dilutions.

Another type of machine divides the washing process into single steps, which are systematically repeated. In this way the whole process can be not only constantly monitored but also accurately calculated.

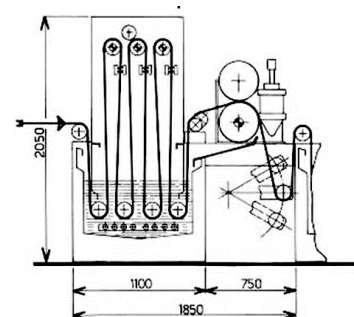

Picture 16 - Open-width washing machine

Inside every separated washing unit, an exchange takes place between the washing liquor and the chemicals-mixed-with-impurities on the fabric in a percentage ranging between 50 and 80%. The washing liquor absorbs both impurities and chemicals. Thanks to a squeezing step carried out by means of squeezing drums assembled at the exit of each unit, the dirty liquor does not leave the unit with the fabric. In the next unit the liquor exchange process repeats once more, but the washing liquor contains always-lower quantities of dirty particles. The repeatability of the process together with the addition of fresh water, are basic elements to estimate in advance the efficiency of the washing process. High-performance washing units, equipped with double-rope system and upper supporting cylinders made of rubber, recommended above all for medium and heavy fabrics, allow the maximum washing efficiency. Upper cylinders, individually driven and equipped with supporting squeezing cylinders, grant an accurate system control. In each washing unit the fabric is soaked twice in the liquor, which washes the fabric by passing through it, and squeezed by the cylinders. The powerful liquor exchange in the fabric is also enhanced by the synergic crosswise flow of the bath.

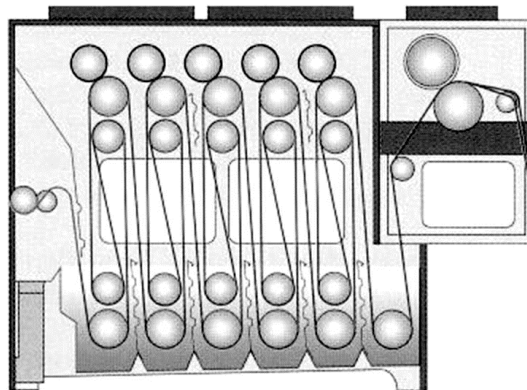

*Picture 17 - Open-width washing unit*

**Continuous washing systems**

From an output point of view, the continuous treatment of fabrics for open-width washing allows operating speeds of at least 25 m/minutes: these speeds are extraordinarily higher than the one obtained with batch open-width or batch rope washing.

The output is also strictly related to the overall dimension of the system (quantity of washing and rinsing units) and can be substantially increased. From a technical point of view, the main problems to be solved in a continuous-system plant, are detergency and relaxation of internal tensions, essentially related to washing processes, above all when carried out with open-width systems. We sketch here below the example of an up-to-date plant, including:

1. a prewashing unit, where the fabric is sprayed with a detergent solution atomized by 7 nozzles: the treatment takes place outside the bath. The solution is collected into the cavity created by the slanting path of the fabric and is forcedly driven through it (Idropress system); the alternating direction of the solution passage allows the treatment on both sides and the particular design of the driving rollers (the roller inside part is driven by a motor and the outside by the fabric) allows a minimum tension on the fabric;

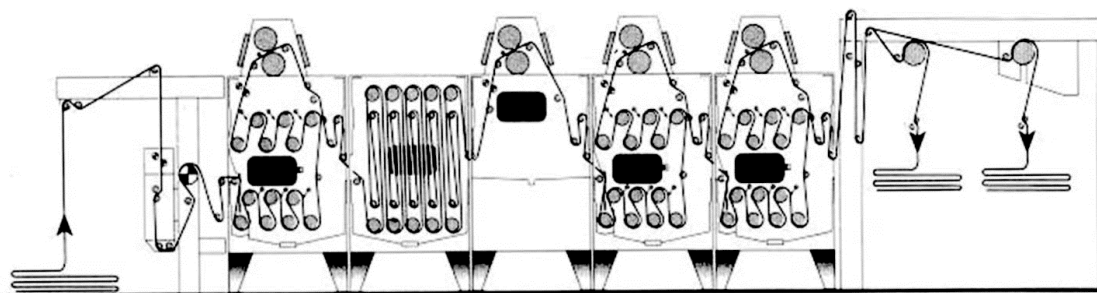

*Picture 18 - Continuous washing range*

2. a soaping–washing unit (working when the fabric is not immersed in the bath), whose capacity (25 and 50 meters respectively) determines the output speed of the plant, since the time needed for the operation cannot be changed (1 min);
3. two or three rinsing units, by means of Idropress system.

An extremely innovative machine features a basic element made up by 8 vibrating fabric guides, which push the water under pressure against both fabric sides, beating them alternatively against the fabric guides; since the flow follows the fabric motion, the effect of the driving tension is also contrasted; this is crucial to allow fabric relaxation in the direction of the warp (obviously, also in all the other machine versions, manufacturers pay the maximum attention to keep tension as low as possible).

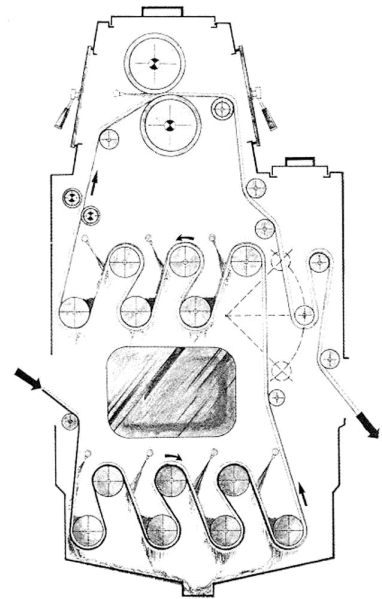

*Picture 19 - Idropress system*

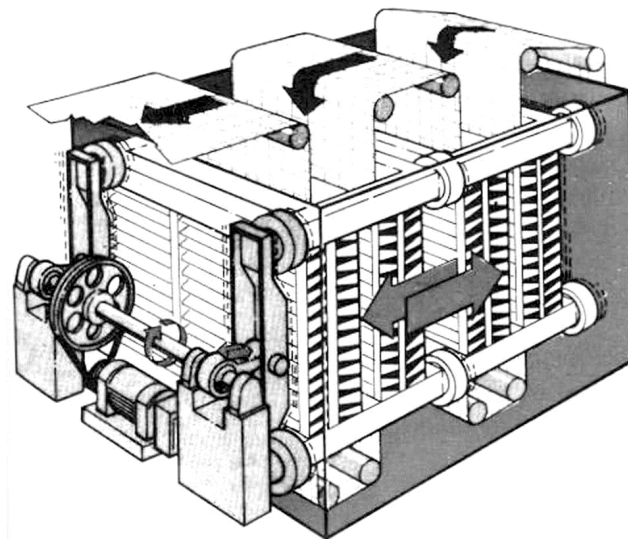

*Picture 20 - Continuous washing: detail of the vibrating system*

Some machines feature special water blade devices (replacing spray nozzles) which convey a huge quantity of water, homogeneously and at high speed, on the whole width of the fabric, thus performing a really efficient wash. The system includes a pipe with a special nozzle releasing water jets similar to blades; these water blades perform a powerful action on the fabric and remove filaments, thickening agents, non-fixed dyestuff, etc. Many of these machines have modular structures, and therefore can be adapted to specific operating requirements.



*Picture 21 - Water-blade washing system*

Among all the possible solutions, manufacturers offer also counterflow washing systems where the fabric flows from the dirtiest section of the washing bath to the cleanest. Through a series of recycling processes it is possible to use the washing liquor many times.

## **Drying**

The frequency of processes, requiring impregnation of the textile substrate (washing, impregnation in dyeing or finishing liquor, desizing and so on), consequently leads to the need of subsequent drying processes, with a high impact on processing costs.

Depending on their nature and structure, textile fibres absorb greater or lower quantities of water; the water absorbed by the textile material is partly retained between the fibres and in the pores of the fabric and partly more deeply in the fabric by the swollen fibres. The water between the fibres or on the fabric surface can be eliminated mechanically while the water in the swollen fibres can be eliminated with a drying processes.

### **General remarks on drying techniques**

The drying process aims at eliminating exceeding water and achieving the natural moisture content of the fibre. Excessive drying can negatively affect the final appearance and the hand of the textile. It is possible to adjust automatically the drying process by means of modern electric gauges. When choosing a drying technique, the cost efficiency of the drying system must be carefully evaluated: the cost-efficiency of a drying process includes many factors such as the quantity of steam, water and energy required to evaporate one kilogram of water as well as the evaporation capacity of a machine, expressed in kilograms of water evaporated in one operating hour.

## **Adjustment of the moisture content in the drying process**

The drying speed is determined by the difference between the tension of water steam on the textile surface and the tension of the water steam in the drying unit: it increases proportionally to the decrease of the moisture content in the air of the unit.

In order to keep this content on low levels it is necessary to blow in the drying units huge quantities of heated air at the same temperature of the drying unit, which leads to huge energy consumption.

When setting the desired moisture degree of the air in the drying unit, it is worth considering that the best degree results from a correct proportion between efficient output speed and cost-effective energy consumption.

## **Adjustment of the drying speed**

The optimum time a fabric spends within a drying unit must correspond exactly to the time necessary to eliminate the moisture on the surface and between the free spaces of the fibres; the stay time must not exceed the optimum drying time (this would cause an extra drying) since the "natural" moisture of the textile must not be eliminated.

The feeding speed of the fabric is adjusted by means of the special devices assembled at the exit of the drying unit, which vary proportionally to the moisture of the fabric leaving the unit.

## **Heating of the drying unit**

The drying units are usually heated by means of steam with an average thermal efficiency of about 64%.

Better thermal efficiency is granted by dryers heated with thermal fluid (about 80%).

Highly efficient heating is obtained by means of direct gas combustion, with an efficiency of almost 95%. The operating temperature can be reached in very short times and heating can be stopped simultaneously with the machine.

## **Hydroextraction**

This process removes the water (the water quantity varies according to the type of fibre) dispersed in the fibres by mechanical action; this process aims at reducing energy consumption and is carried out before the final fabric drying or between the various wet processing stages (washing, dyeing).

It can be carried out in the following ways:

- *squeezing*:

the water dispersed on the surface and in the spaces of the fabric is removed by means of the pressure applied by two cylinders.

- *centrifugation*:

this process eliminates the greatest quantity of water dispersed on the surface of the textile by centrifugal force. It is applied above all to resistant yarns, knitted goods and fabrics.

- *steam pressure*:

a high-speed steam jet blown on the whole width of the stretched fabric passes through the cloth and eliminates the water in excess. Extracted water and steam are condensed and reused.

- *vacuum*:

this method applies vacuum technology and is used to dry very wet fabrics or delicate fabrics that do not stand up to the pressure of the cylinders of a squeezing unit, which could negatively affect the surface structure. The stretched fabric slides open-width above the opening of a cylinder-shaped structure connected to a suction system. The air drawn from outside removes the exceeding water when passing through the textile cloth.



Picture 22 - Vacuum drying machine

## Drying systems

The water dispersed in a textile material by chemical-physical process is generally eliminated by the action of hot air, which makes the water evaporate; during the drying process, it is very important to carefully consider the way heat is directed on the fabric.

The drying process can be carried out:

- by heat convection
- by contact with heated metal surfaces
- by infrared radiation
- by means of microwaves or high-frequency waves
- by combustion

Yarns and textile materials in bulk are generally dried inside hot air compartments. For the drying of piece fabrics, manufacturers have designed different drying units, which apply different principles, briefly described here below.

### *Drying by heat convection*

The heat diffusion onto the wet fabric is carried out by means of hot air circulating inside the drying unit. There are two different types of dryers applying this operating principle: compartment dryers and tunnel dryers.

#### 1 – Compartment dryers

Suspended fabric dryer: it is made up of hot air compartments where the folded fabric with a maximum width of 3 meters is suspended on a series of rotating cylinders leading the fabric toward the exit. The circulating air is blown slowly downward. This system is suitable for light and medium-weight fabrics that can withstand the stress of mechanical feeding.



Short-loop dryer: this system eliminates almost completely the tension applied by the fabric weight; it also avoids the risk of possible downward migration of dyestuff or finish.

Hot-flue dryer: the vertically folded fabric is guided through a hot air compartment. The feeding motion is determined by means of different sets of rollers, while special cylinders separate the fabric folds. The drying temperature ranges between 80 and 100° C. This drying system is suitable for printed fabrics, above all for light and medium-weight fabrics, as well as the intermediate drying after printing, after impregnation in general, and after the application of background dyes and other similar operations.

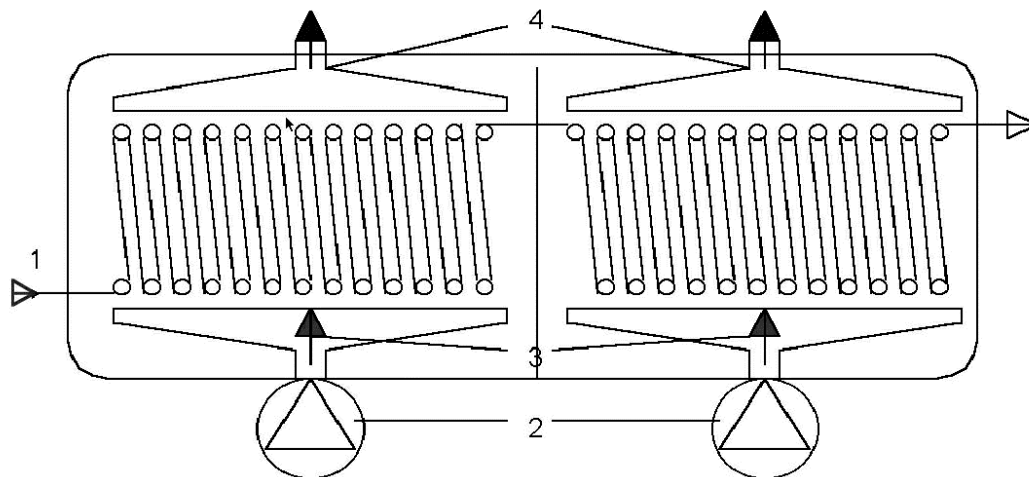

*Picture 23 - A hot-flue*

*1 Fabric; 2 Heaters–blowing units; 3 Hot air blow; 4 Exhausted air blow*

The use of belt or perforated-drum dryers is often extremely effective to cut costs and increase output rates in continuous drying processes on fabrics and yarns in various forms.

Thanks to suction effect of the hot air drawn into the cylinder through the holes, the fabric perfectly adheres to the external side of the rotating cylinders, moving forward inside the drying unit where it is dried gradually.

## 2 – Tunnel dryers

Supporting nozzles dryers: the fabric is suspended on an air cushion generated by blowing nozzles arranged in proper layout.

Stenter: it is made up of modular elements (arranged lengthwise and heated by means of forced hot air circulation) where the fabric passes horizontally, supported by a belt, by supporting nozzles or by air cushion.

When the hot air comes into contact with the fabric, it cools down and removes the evaporated moisture.

The air is partly drained and replaced by an equal quantity of fresh air.

The remaining air is recycled, added to with fresh air and passed again through the heating element.

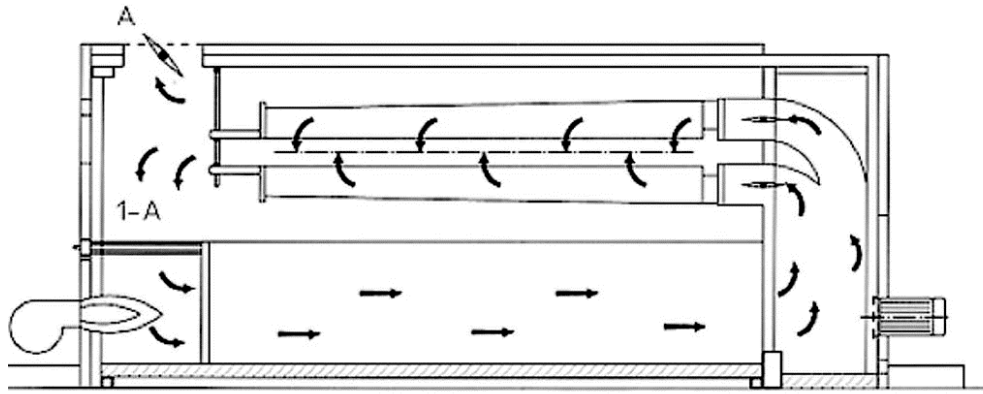

Picture 24 – Air flows inside a stenter featuring a hot air convection drying system

This machine is extensively used in the fabric drying sector, but is also used for the heat setting and polymerisation of finishing or bonding agents in pigment printing processes; it includes an “entry” area for the fabric provided with a pad-batch, where finishes and finishing products are applied or where the fabric is simply squeezed.

The use of a drum coated with porous material, which dehydrates the fabric before the drying step, proves particularly efficient.

The unit is equipped with a stretching system to keep the fabric stretched and also with a special device that controls the perpendicularity of the weft to the warp.

All the drying systems are assembled in the second section; they include a feeding system equipped with a fabric guiding system and the drying unit.

The endless chains, with clips or pins for fastening the fabric, are positioned all along the front part, the drying compartment and the exit section; they guide the fabric by the selvedge. At the exit the fabric is released automatically from the fastening devices and wound up.

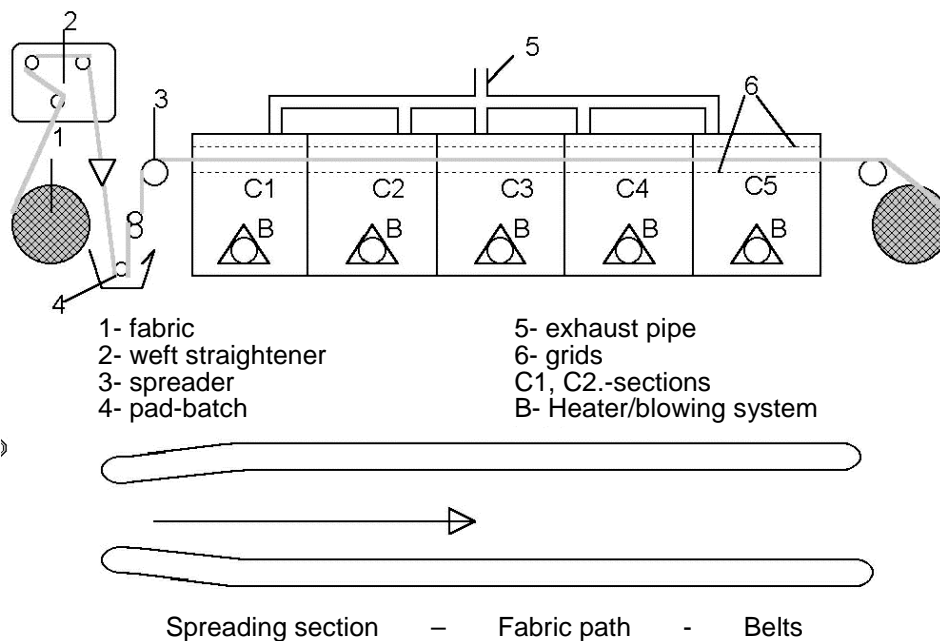

Picture 25 - A stenter

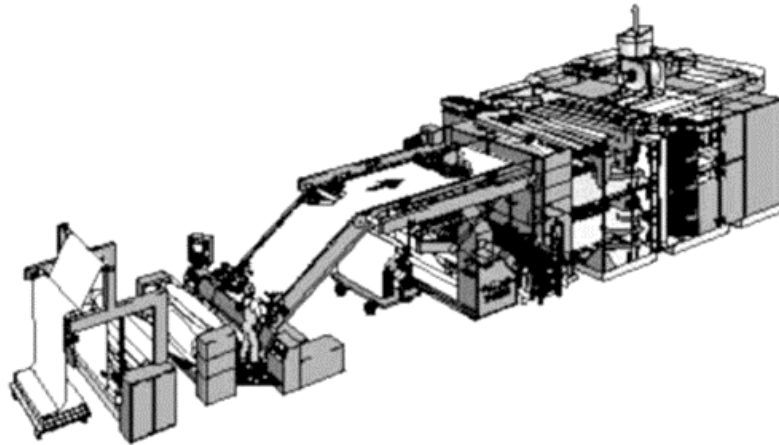

*Picture 26 - Multi-level stenter with fabric entry and exit on the same side*

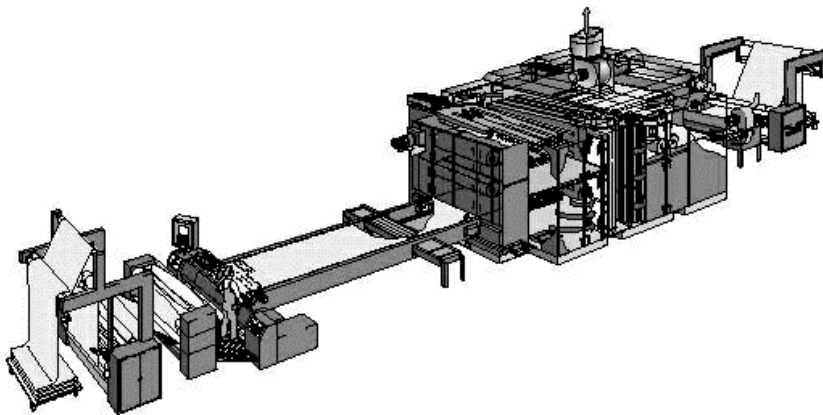

*Picture 27 - Multi-level stenter used for coating processes and incorporated on an existing operating line*

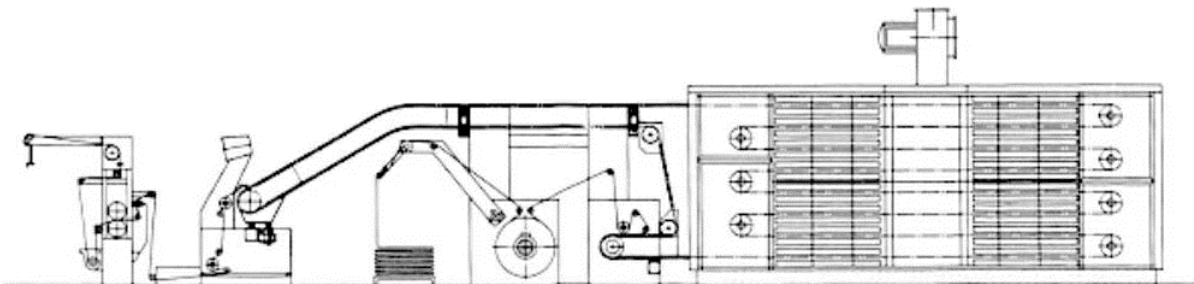

*Picture 28 - Longitudinal section of a multi-level stenter with internal exhaust channels*

In the latest generation of stenters, manufacturers have tried to improve the quality of the fabrics with more rational fabric feeding systems and innovative solutions for heat treatment and reproducibility of the various processing stages. Together with an increased output in continuous operating conditions, manufacturers also aim at improving the machine utilization, reducing maintenance to a minimum and cutting energy consumption.

## Multi-level stenter

Thanks to an excellent ratio between capacity and overall size, the multi-level stenter is also particularly cost effective for treatments requiring a certain stand-by time, such as for example the heat setting of synthetic fibres, chemical treatment setting and carbonising. The diagram shows a comparative evaluation of production costs with a flat stenter and with a multi-layer stenter: drying kges vary according to gw fabric weight.

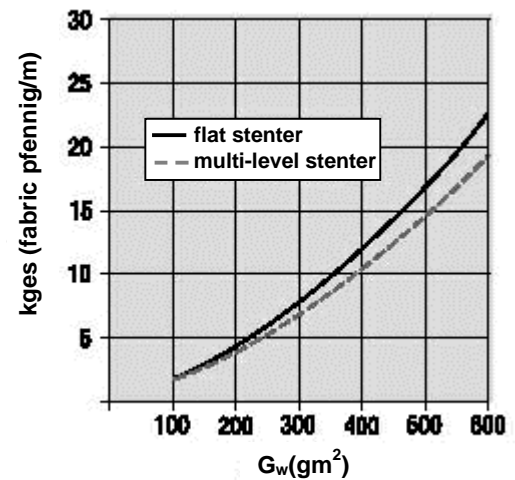

Advantages of the multi-level stenter:

- Compact structure: thanks to the multi-level design, the overall space required for the installation of the stenter is smaller than the one required for a standard flat stenter with the same output rates.
- High-performance drying process: for heavy textiles the efficiency of the machine does not depend on the evaporation on the surface but on the time required for the drying process. Powerful ventilation, generally applied to flat stenters, could cause an excessive drying of the textile surface and damage the material, while fibres inside the fabric could remain wet. The internal moisture migrates very slowly to the surface.
- Delicate drying: in a multi-level stenter, the drying process does not affect the material negatively and eliminates the moisture in the best possible way. In fact, we know that a delicate treatment, e.g in a drying or heat setting process, can be ensured only with a slow ventilation of the material. Furthermore a longer treatment time, even at lower temperatures, gives a better appearance to the finished material, compared to tougher treatment conditions. The result is a bulky fabric with a softer hand, which gives the sensation of more weight.
- Lower operating costs: thanks to reduced number of operators, smaller space required, slight reduction of the yield for heavy textiles and reduced consumption of energy with the same output rate of a flat stenter.

Limits of multi-level stenters:

- only a few multi-level stenter models can be equipped with pin chains.
- in the path between one level and the next one, the fabric must be sustained to avoid the formation of wrinkles and therefore deformation. Telescopic drums are used to convey the piece of cloth by moving forward the whole fabric width thus sustaining it from one selvedge to the opposite one; unfortunately with delicate textiles, such as raised velvets and very lustrous viscose fabrics, this system causes evident and unpleasant stripes and marks on the surface.



*Picture 29 - Flat stenter*

*Contact drying*

Drum dryer: with this system, the fabric moves forward arranged on several heated drums. The drying temperature ranges between 120-130° C and the cylinders are heated by means of steam at a pressure of 1-3 atm. This very efficient and low-cost drying system is particularly suitable for flat fabrics, with slightly evidenced structure, which cannot be easily affected by tension during feeding. Used for intermediate drying and for light finishes; this system is not suitable for durable thermosetting resin finishes.

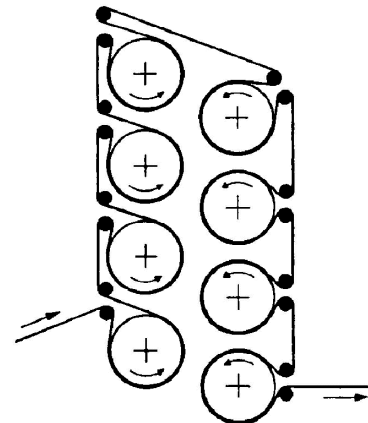

*Picture 30 - Drawing of a drum dryer*

*Infrared radiation drying*

Infrared radiation (near and medium infrared field) can be absorbed by the fabric and transformed into heat by energy "degradation".

In fact their absorption intensity is proportional to the vibration levels "excited" by the bonds of the atomic groups from which the passage to the basic level takes place by means of energy release.

Therefore only radiation with a wavelength corresponding to the absorption levels of the textile material is absorbed by the textile material and therefore transformed into heat.

The capacity of a large amount of radiation to penetrate deeply corresponds to its capacity to develop heat inside the material.

This can be highlighted for example with cellulosic fibres, whose absorption spectrum in the near infrared field being such as to:

- a) radiation with wavelength  $\lambda = 2.5 \mu\text{m}$  is only partially absorbed; it releases a small quantity of heat and passes through a very thick textile.
- b) radiation with wavelength  $\lambda = 3 \mu\text{m}$  is highly absorbed by the fabric and therefore it does not penetrate the surface, to which it releases all its energy in the form of heat.
- c) radiation with wavelength  $\lambda = 3.4 \mu\text{m}$  corresponds to a medium absorption; it partially penetrates the material and creates a heat source inside.

Also water absorbs infrared radiation (its maximum absorption is equal to  $3.5 \mu\text{m}$ ).

If we consider that this is the absorption wavelength for almost all the textile materials (cellulosic, polyamide and protein fibres) as well as water, the same area can be considered the most important section of the infrared field for the drying process.

In fact these degrees of radiation feature, in almost all the textile materials, an excellent absorption coefficient on the surface and therefore a quick heating potential, which leads to an excellent thermal efficiency.

This section represents only a small part (from 3 to 7%) of the infrared radiation emitted by a standard source.

$3 \mu\text{m}$  radiation is also absorbed by water vapour, while that with a lower  $\lambda$  passes through the water vapour with insignificant absorption levels.

The infrared radiation sources, generally used, are characterised by a different emission spectrum and can be divided into three main categories:

- a) short infrared radiation lamps;
- b) incandescent emitters (for medium infrared radiation)
- c) no-light infrared emitters (for long radiation).

The presence of bonding agents, dyes and finishing products on the fabric does not modify the absorption spectrum and therefore has slight impact in most cases.

### *Microwave drying*

The application of microwaves and high frequencies in fabric drying

The heat transfer in the fabric, from the surface toward the inner part, takes place with a certain difficulty due to the poor thermal conductivity of the fabric with subsequent problems to obtain a temperature uniformity in the whole heated mass, in relatively short times.

By means of radio frequency waves, heat develops inside the material in a quantity that is proportional to the water dispersed in it.

In fact, water molecules subject to an electric field are polarised in the direction of the electric field: in an alternated electric field, each field displacement corresponds to an inversion of the polarisation direction.

Water molecules in an alternated electric field are forced to displace by oscillating with the same frequency of the field, thus dissipating energy by effect of molecular friction.

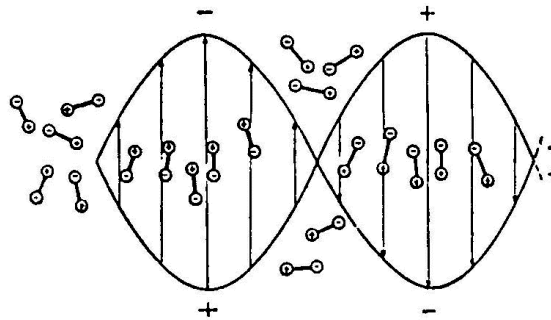

Picture 31 - Action of the electromagnetic field  $P = K \cdot E^2 \cdot f \cdot s$   
 ↻ Dipole molecule                      ↑ Electromagnetic field vector

The energy produced by oscillation heats the material (with no need to heat by contact or convection) and the heat quantity developed is determined by the frequency and the intensity of the electric field as well as by the oscillation power of polar molecules. This potential of non-conductive molecules is expressed by means of dielectric quantity, called loss or dissipation factor:

$$P = K \cdot E^2 \cdot f \cdot \sigma$$

where

K = numerical constant

E = intensity of the electromagnetic field

f = frequency of the electromagnetic field

$\sigma$  = material loss factor

Only polar or polarisable materials with specific translational and/or rotational freedom can be heated, while textile polymers with stiffly linked long chains do not have a suitable structure to vibrate and therefore to absorb energy. For this reason the water dispersed in a textile material, thanks to its polarity and to its mobility, has a “loss factor” about 100 times higher than the dry fibres one.

Therefore a wet material can absorb a quantity of energy proportional to the water dispersed in it: the more the moisture decreases, the more the dissipated energy reduces.

Furthermore, if the moisture is dispersed irregularly in the fabric, a greater quantity of heat will develop in the areas with higher water content, with a consequent higher evaporation. This leads to a fast and homogeneous thermal action, which stops the drying once the desired moisture content has been reached by simply controlling the dissipated power. The unit includes a feeding belt running in an area with a strong magnetic field with a quick transition from one polarity to the other, resulting in a quicker system compared to standard warm-air dryers with a smooth final drying and accurate residual moisture values. The design of special electrodes allows the transfer of radio frequency energy simultaneously with the delivery of warm air. Considering that the penetration depth of electromagnetic waves is inversely proportional to their frequency and in order to avoid signals interfering in telecommunications, the international frequency bands assigned to these drying systems are the following:

Radio frequency: 13.56 and 27.12 MHz.

Microwaves: 915 and 2,450 MHz.

Usually high frequency is applied to very thick fabrics (hanks, packages, bales) or to produce fast binding of latex layers, while microwaves are used for high-speed thermal treatments of yarns and fabrics.

A drying unit includes the following elements:

- a) generator;
- b) electrodes;
- c) drying compartment;

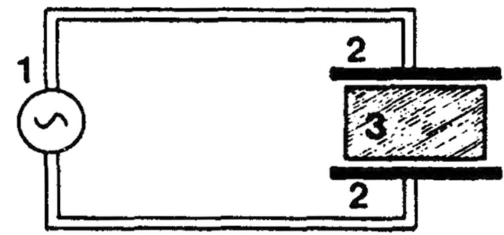

High frequency drying

- 1 Source of electric current
- 2 Condenser plate
- 3 Fabric

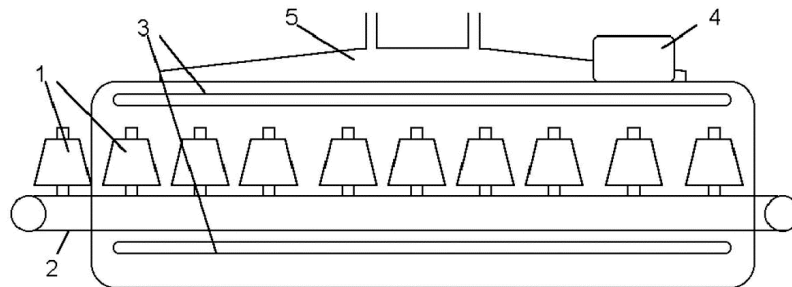

Picture 32 - Picture and operating scheme of a radio frequency drying unit  
 1 – fabric 2 – feeding belt 3 - electrodes 4 - generator 5 – steam exhaust

#### Combustion drying (Remaflan process)

Fabrics are dried by exploiting the combustion heat of an organic solvent spread over the fabric.

The application of the finishing products is carried out by means of padders, which apply a solution of finishing products in a hydro-alcoholic mixture, 36% of which is made of methyl alcohol.

The fabric enters vertically in the drying unit, on the vertical axis of the pad-batch, where a short path through infrared heaters give rise to the evaporation of the methyl alcohol and to the ignition of the vapours (the ignition temperature ranges between 31 and 37°C, according to alcohol concentration; the ignition temperature of anhydrous methyl alcohol is 11°C).

Since the size of the drying tunnel is very small, the temperature in the combustion area reaches 600-750°C; if we consider that a liquid evaporates by heat absorption, the treated fabric, when releasing its moisture, maintains a temperature ranging between 45 and 70°C, which allows delicate and fast drying.

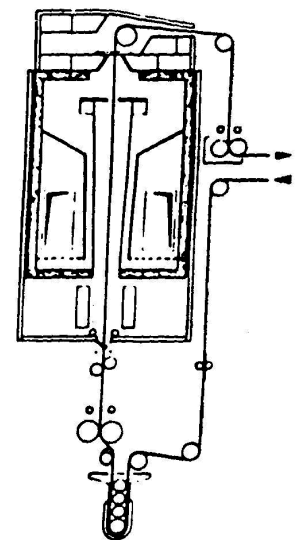

Picture 33 -  
 Combustion drying

The fabric feeding speed, depending on its characteristics, is adjusted by means of automatic devices according to the residue moisture desired (in medium-weight fabrics the speed is of about 40m/min). Since the evaporation of methyl alcohol requires less energy than the evaporation of water and since only CO<sub>2</sub> and water originate from its combustion, Remaflan process proves to be not only a cost-efficient but also a pollution preventing drying method.