

In simple terms, it must be remembered that virgin fibres (first processing), tough, long and fine, are employed to obtain combed yarns.

For carded yarns, virgin fibre with physically and mechanically inferior characteristics are used than for combed yarns, in addition to a small quantity of recovered and waste fibre from the combing cycle.

Finally, for open-end yarns, mainly very short fibres are used, both virgin as well as work waste. In this latter case recovered from the combing cycle (combing waste, noils) or from the carding cycle (waste, noils).

The general aspects of cotton spinning have been established, and now the stages of the processing cycle will be described, common to each of the three working cycles looked at, and these aspects are: opening and cleaning, carding, doubling and drawing.

## **Raw Stock Opening and Cleaning**

Before entering into a specific description of opening, we must take a look at one of the most important concepts that characterises spinning in general and whose origin lies in the opening stage itself: the *concept of blending*.

Usually, the spinner possesses (in his storeroom) batches of bales from at least four diverse sources; the quantities of material can be very different from each other, as can be the purchase cost. For example, in a hypothetical storeroom there could be: 100 bales of type A, 150 of type B, 200 of type C and 300 of type D.

The blend obtained with cotton from different sources means that any eventual shortcomings in the supply of a particular type of cotton with definite characteristics can be overcome, substituting one type with one with similar characteristics but of another source.

From a quality point of view, the fibres that make up the same blend must necessarily possess the same staple length (average length of the fibre making up the batch), but also the fineness, resistance, degree of cleanliness and maturity must also be extremely similar. For this reason, a small sample of material is taken from each bale to undergo a series of technological analyses in order to arrive at a blend of optimal composition; this is made possible by the use of highly technological apparatus such as the HVI (High-Volume Instrument).

The blend is an important operation both for obtaining a good yarn as well as for reducing the price quality ratio to a minimum.

Independently from the processing cycle used in the mill (carded, combed, open-end), the raw cotton must be opened, meaning it must be extracted from the bale that was packed where it was cultivated. This is done with special machinery called a bale plucker. The spinning manager determines the quantity of bales that must be taken to the plucker and which will make up the so-called number of bales in the blend, meaning the number of bales being processed. Depending on the production type and the type of bales being processed, this number will range from 20 to 80 units. In order to obtain and permit long-lasting production homogeneity over time, it is a good idea to put together a blend in such a way that a number of bales proportional to the quantity of bales present in the storeroom exist. So, for example, if a blend made up of 45 bales were required, with a storeroom as described above, it would be possible to take to the plucker 6 bales of type A, 9 of type B, 12 of type C and 18 of type D, which will be lined up, or alternatively placed as described in Figure 1.

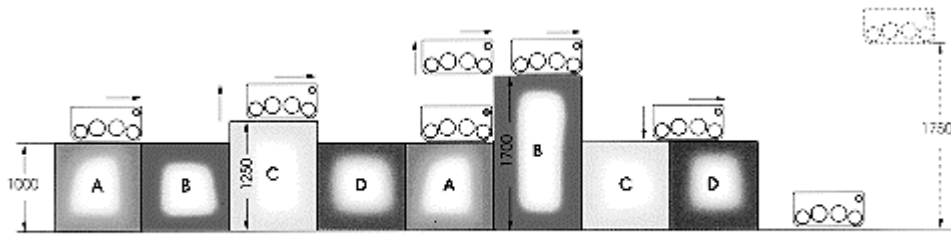

*Fig. 1 Example diagram of the bales being blended by the plucker*

The description is purely an example; in reality, a small number of variables capable of influencing the choice of type and quantity of bales being blended intervene, such as:

- the cost of fibre (depending on the source, with every other condition being similar, the difference of cost can vary even by some tenths of cents of dollars per pound);
- the total cost of the finished product and the relative sale price expected;
- the weight of the individual bale (depending on the source this could range between 120 and 270 kg);
- the intrinsic quality of each type of fibre compared to the others;
- how easy or difficult it is to find a raw cotton supply.

Thanks to the use of blends constituted from different sources, the mill can produce yarns with the same dyeing behaviour, or with the same mechanical features (like elasticity and resistance to traction) for long periods of time. This is good for the company as it means the business can have a serious and consistent reputation in the textile world, at least from the point of view of homogenous quality of the finished product.

The bales arrive at the tuft plucker (Figure 2 and 3) wrapped in metal supports or covered in a jute, cotton or polypropylene cover. They are opened by suitably trained workers and taken to the plucker area. This stage is extremely important, both from the point of view of personnel safety (risk of injury while the packing straps are cut) as well as the high risk of fire, caused by the presence of the metallic fragments that could be present inside the raw cotton, creating sparks during the processing and consequently posing a risk of combustion. In order to reduce the presence of metallic elements of raw cotton, spinners adopt various solutions such as sensors to detect metal, or the use of magnets, that identify metal and remove the mass of fibre that surrounds it.

The detrimental habits of cotton growers to cover bales with fabrics made of polypropylene, and using polypropylene sacks during the harvest of the fibres, leaves a presence of polluting fibre fragments that lurk between the cotton fibres and remain trapped in the yarn through the process until the fabric is made, causing serious quality problems. In actual fact, the uncoloured polypropylene fibres are often missed during controls because they cannot easily be identified by the equipment that uses special cameras located in the plucking line and see the cotton only on the basis of the fibre colour.

The tuft plucker is the only 'mobile' machine used in spinning; during the process, the main unit travels up a track in order to pluck the cotton laid out along its route, and this is the origin of its name.

As the diagram (Figure 2) shows, the plucker has a control panel (1) on which the main machine operational functions are set. The plucker carriage (3), supported by a rotating tower (4), internally contains two plucker cylinders (6), covered with spikes made from a special tungsten-carbide alloy, capable of extracting raw cotton from the bales being processed (2). The high number of blades with spikes – up to 254 are located on both of the two plucker cylinders - allow the tufts to be opened to a certain degree when the bale is plucked, making the successive repeated untangling easier.

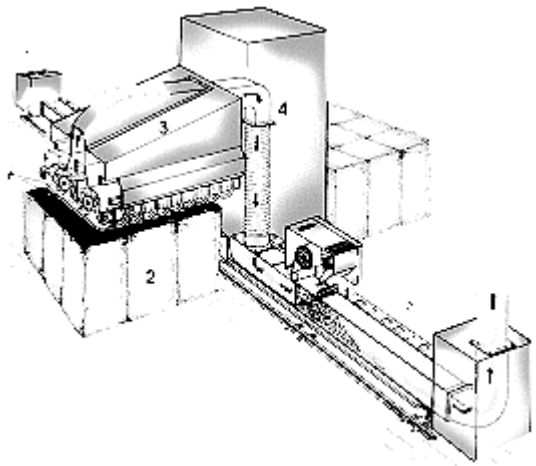
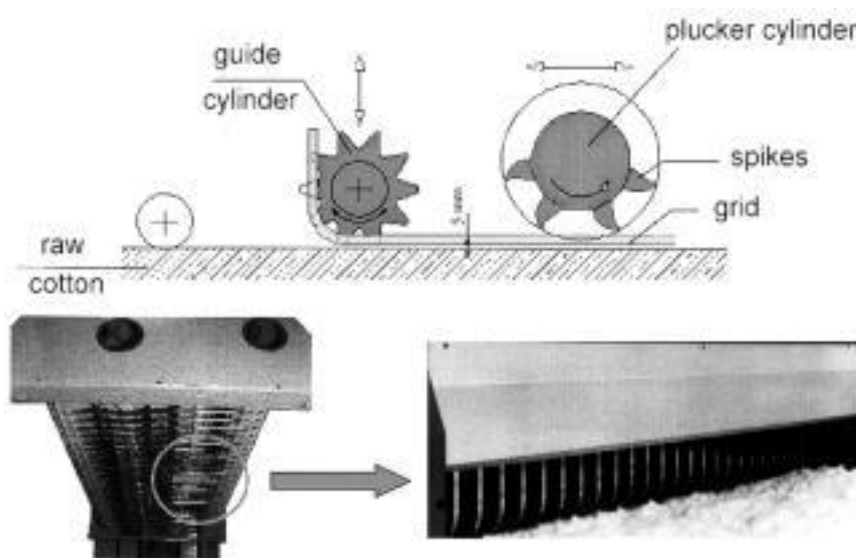

*Fig. 2 Diagram of a bale plucker*

As shown in the diagram below (Figure 4), the spikes of the plucker cylinders stick out from the grid, and as the distance between them and the surface of the bale can be adjusted, it is possible to adjust the amount of material plucked.



*Fig. 3 Bale plucker*



*Fig. 4 Close up of the grid and blades with plucker spikes*

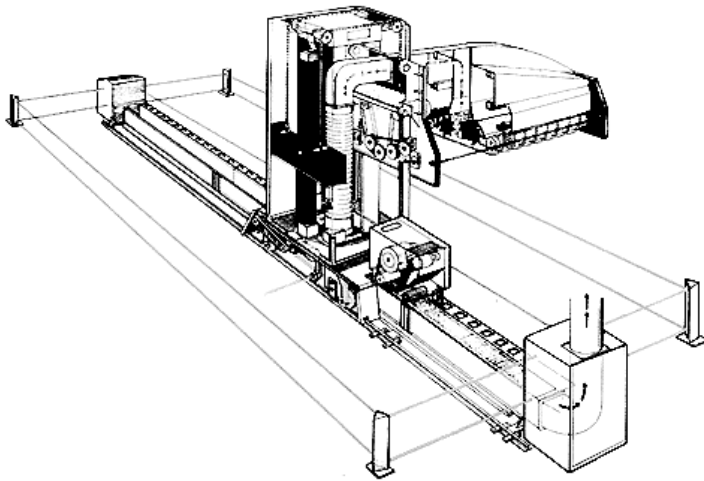

Fig. 5 A cut-away view of the bale plucker

Figure 2 shows how the transport conveyor (5) takes the cotton tufts to the aspiration conduit, which in turn takes them to the next machine.

We mentioned above that the blend often consists of bales of notable and irregular height and size, as they come from different locations of cultivation. The carriage is equipped with a device carrying a photocell that automatically raises or lowers the carriage when the profile of the bales being blended vary compared to the bales being processed (2), meaning the material is plucked in

a regular and uniform manner, almost eliminating the quantity of residue raw cotton not collected from the ground.

The production rate limit, that can be obtained by a carriage of 1,700 mm deep, can reach 1,150 kg/h, while in the 2,250 mm version, the production rate rises up to 1,600 kg/h.

Work safety is guaranteed by a series of barrier photocells, places around the plucker operating range. See Figure 5, which shows (among other things) the light beam of the barrier photocells, located around the edges of the machine operating range.

Although this section of the handbook focuses on the production of pure cotton yarn, it is necessary here to at least mention the production of yarns in *intimate blend*, meaning those processed in blends made up of between 2 and 4 types of fibre, with different fibrous composition, and consisting in:

- alternatively plucking each component from the relative bale and placing a high quantity on the respective blender;
- completing an intense opening stage (only for cotton fibre);
- placing the material on a special blender conveyor, in such a way that the quantity of each component is relative to the percentage desired;
- taking the multi-component material, first to the blender and then to the card, following the related processing cycles.

Where small batches of production are required, as opposed to the automatic plucker described above, plucking raw cotton from the bales is done manually and the rough untangling of tufts is done by a weighing feeder (Figure 6), a machine equipped with a feeding table (1) where the laps of raw cotton are deposited manually. The raw cotton is taken by the feeder table (3) to a blending chamber where a series of spikes arranged on the vertical apron (9), holds the material and takes it towards the delivery stage.

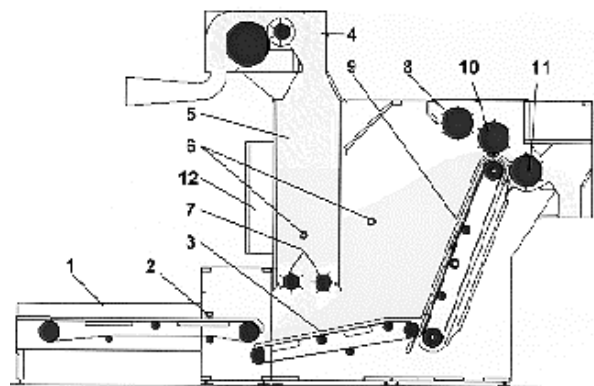

Fig. 6 Section of weighing feeder

The equalising cylinder (10) rotating in the opposite direction to the advance of the apron, permits the passage of only those tufts held by the spikes, while returning the free tufts to the blending chamber. Finally, the removing cylinder (11), which rotates in the same direction as the apron but at a higher speed, removes the fibre from the spikes and unloads it in the weighing room, carrying out an initial rough disentangling.

This weighing feeder can be fed automatically, and in this case the material is returned by an aspiration cage (4), which deposits the material in a reserve hopper (5) at whose base there are two delivery rollers (7) which unload the material onto the feeder apron mentioned above (3).

From the first fibre processing steps and until the carding stage, the material is transported by an air flow, while inside the individual machines special aprons, cylinders, reels and fixed sectors are used, covered by steel spikes of various shapes and sizes. It is in fact this symbiosis in the use of the spikes and in the way they interact that the fibre tufts are disentangled and the fibres parallelised.

After the fibre tufts are plucked, they encounter the aspiration cage (Figure 7) which dedusts the tufts while taking them to the axial double flow opener; this is available both with incorporated motorised blower (6), as well as motorised blower installed separately, depending on the mill's needs. Through the entry mouth (1), the dusty material enters the feeding chamber (2) and is deposited on the perforated drum (3). The difference in specific weight between the fibres and the dust is such that the latter is separated from the raw material and a special doffer cylinder (4) takes care of dividing the dedusted tufts, which then go on to the next machine.

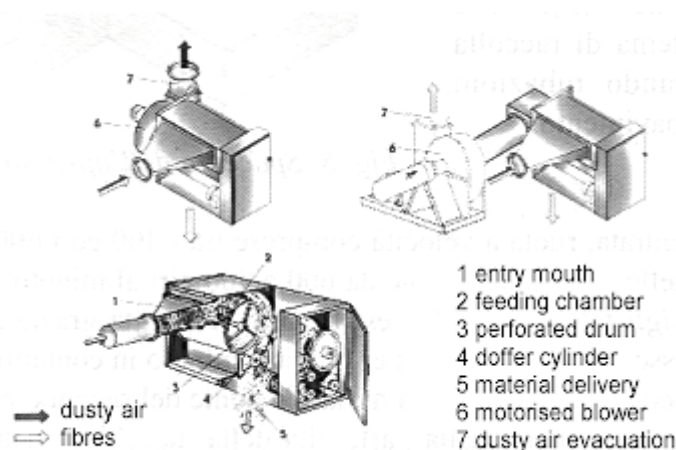

*Fig. 7 Diagram and cut-away view of the aspiration cage*

The dedusting effect is extremely useful both to improve the quality of the partially processed material, as well as for increasing the production rate of the preparation and spinning machines downstream. Furthermore, it reduces curling of the fibre while the material is being transported from one machine to another. In depth studies have shown that the presence of dust reduces the production output of open-end spinning frames, therefore in such lines a special dedusting machine for cotton being processed is included.

In consideration of the function carried out by the aspiration cages, these are used in various points of the processing line.

The roughly opened cotton - on exiting the plucker or feeder - is taken to the horizontal opener, whose main functions consist in:

- . the opening of raw cotton, in order to reduce the weight and volume of the fibre tufts and permitting the disentangling of the individual fibres;
- . cleaning of the raw cotton, by beating, with the elimination of foreign matter such as sand, dirt, vegetal fragments, dust (the waste material during the opening stage is generally referred to as *trash*).

The axial double flow opener (Figure 8), permits a delicate but efficient opening of the fibre tufts and at the same time dusts them, producing up to 1,250 kg/h of opened material.

Through two cleaner cylinders (1) and special automatically adjustable grids (2), the waste particles (vegetal residue, dirt, sand), but also fibre fragments, are separated from the fibrous tufts and delivered to the waste unloading cylinders (3), that lead to a central collection system that makes use of tubes running below the floor.

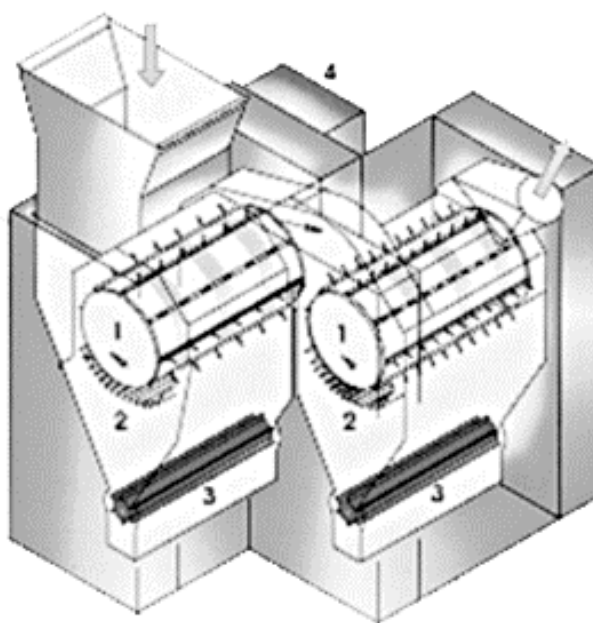

Fig. 8 Cut-away view of the axial double flow opener

The entry cleaner cylinder rotates at a speed of between 400 and 600 turns a minute, while the second cylinder (exit) turns at a rate of between 600 and 900 times a minute.

The formation of *neps* is drastically reduced by the absence of fibre gripping spikes. The fibre falls downwards thanks to gravity, it comes into contact with the spikes on the first cylinder, it is thrown against the grid, it encounters the spikes of the second cylinder, is beaten against the related grid and finally exits from the top end of the machine, drawn by the sufficient air flow.

The machine is equipped with a control panel, capable of saving all the adjustments that are step by step made and programming the ones to make, which are:

- varying the speed of the two cleaner cylinders,
- adjusting the degree of opening,
- changing the angle of incidence of the grid knives, with respect to the tuft beating direction,
- controlling the quantity of waste generated,
- the option of working with two distinct blends, as the machine automatically adapts to the pre-selected processing positions.

The high speed of cylinder, together with the presence of pointed metal rods, determines a violent impact against the grid (formed by small triangular bars) and as a consequence of the highest specific weight of the foreign matter (as opposed to cotton) the trash separates from the fibre, passes through the grid and is taken towards a special container located away from the machine.

The *intensity of opening* is a fundamental factor above all in this stage, as it is necessary to disentangle the tufts and eliminate foreign matter, but at the same time any damage to the very delicate fibre must be prevented. This depends essentially on the following conditions:

1. *the opener feeding system*, which can be:
  - . *free mass* when the tufts driven by the air flow come into contact with the cylinder rods, without being retained by feeding devices;
  - . *in laps* when the tufts, on passing from the cleaner cylinder rules are retained by an apron (on the right of the diagram) and a feeder cylinder, and are delivered in the form of laps; the lap feeder can be either vertical or horizontal. In the first case, the tufts escape the action of the rods after having received just one beat; in the second case, after the first beat, the tuft rebounds on the grid and comes once again into contact with the cylinder rods, that beat it further. The vertical lap feed provides a higher degree of opening;

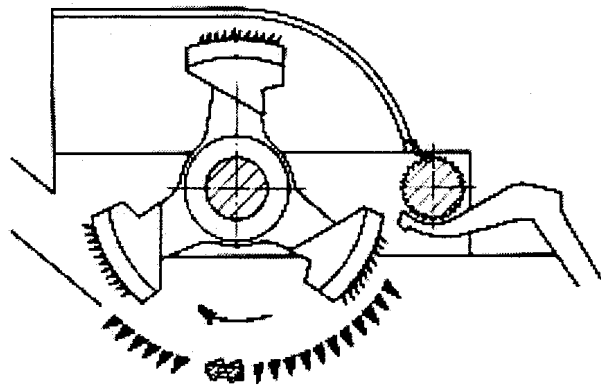
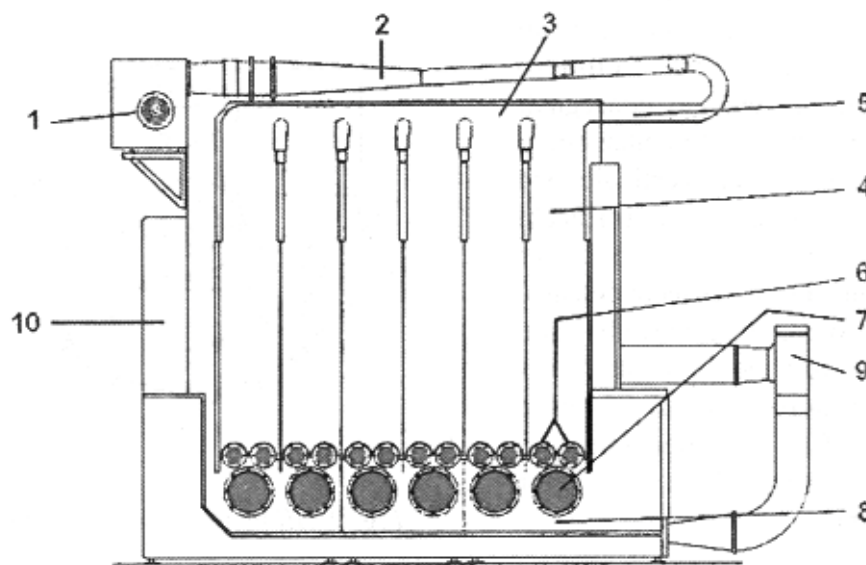

Fig. 9 Horizontal lap feeding

2. *the rods section*, that can be flat or round: the first type have a stronger hold on the tufts and therefore offer a higher degree of opening, but they risk defibrating the fibres even more; the above mentioned action is increased if the rods are sharp;
3. *the angular speed of the cylinder*, as this determines the number of beats that the fibre is subject to and the centrifugal force that they undergo as an effect of the rod beatings;
4. *the distance between the grid and the cylinder rods*: in fact with the minimum distance between them the highest degree of opening is achieved, as the tufts hit the grid at the top speed;
5. *the distance between the small bars of the grid*, which can be varied by rotating the bars on their longitudinal axis by a lever or a wheel: reducing the distance between the bars reduces the degree of opening and cleaning;
6. *the distance between the feeder cylinders and the cylinder rods*, which depend on the average length of the cotton being processed, generally this distance must increase proportionally to the length of the fibre, as the latter could get ruined or break under the beats from the rules;
7. *the air flow*: varying the air flow that accompanies the fibre during the processing cycle, the time the cotton remains in the machine changes and therefore so does the degree of opening.

On exiting the horizontal opener, the tufts enter the blender (Figure 10), a machine of fundamental importance in the cotton processing cycle, which carries out the blending of the tufts by distributing the material inside special cells. There are between 4 and 8 cells and production as a consequence ranges between 800 and 1,200 kg/h. Thanks to the motorised blower (1), the fibre tufts are driven towards the feeder channel (2) and reach the distribution channel (3) after having come into contact with a pressure transducer (5) whose task is to control the quantity of cotton present in the blender cells and therefore command machine feeding acting on the previous machine. The tufts are deposited in the vertical cells known as blending cells (4); in this way the cotton forms layers made up of material from different bales being processed. The raw cotton is uniformly compacted by the weight of the tufts themselves and is collected by a pair of feeder rollers (6) and an opening cylinder (7), placed at the base of each cell. The angular speed of the feeder rollers is not identical for all cells but varies with the aim of maximising blending between fibrous tufts.



*Fig. 10 Section view of six cell blender*

The opening cylinder carries out further separation of the tufts and delivers them to the blender channel (8) where all the material extracted from the cells is gathered. An air current takes the cotton to the next machine. A by-pass valve acts in a transverse manner, capable of separating the process air from the material. Processing parameters can be set up on the control panel (10). The importance of the role played by blending of fibre in the cotton spinning process cannot be stressed highly enough. Blending carried out by setting up the bales in process and the successive method used for plucking the laps continues in all the machines used in the opening process, but it materialises in the use of the blender, a machine of relatively recent conception, which took off as recently as the 1970's. Because of the construction form of the machine, the cells are gradually filled and above all they are not filled uniformly with one another, as lighter tufts are easily pushed to cells further away (on the left, see Figure 10). As will become evident below, the blending of tufts and fibres continues even in the machines that will be later described and especially in the card, the drawing machine, the lap drawing frame and the combing machine.



In order to increase the action of cotton cleaning, at the exit of the blender (where requested) there are one or more opening points, this time with horizontal lap. There are two technical solutions for this:

- the *single-cylinder opener*, which is suitable for 'roller' cottons (meaning fine and long fibre cottons) which have been subjected to cylinder ginning, and which therefore carries out an intensive but not aggressive action;
- the *three-cylinder opener*, designed on the other hand, for 'saw ginned' cottons (generally medium-short length fibre, with a characteristic high content of vegetal impurities), that carries out an extremely intense but still not aggressive action.

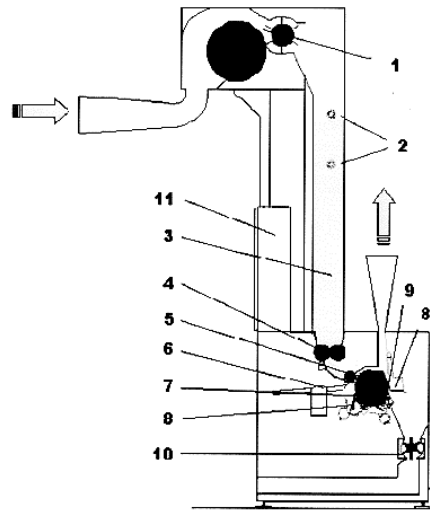

*Fig. 11 Close up and section view of the single-cylinder horizontal opener*

The single-cylinder opener (Figure 11) is defined as being horizontal because the feeder roller (5) carries out the lap of opened material in such a way that the opener cylinder (7) seizes it horizontally. The opener cylinder possesses a process width of around 1,200 mm, a diameter of over 400 mm and an angular speed of between 600 and 1,100 turns a minute.

The machine permits an optimal degree of opening, dedusting is efficient and output can reach 600 kg/h. On the control panel (11), the necessary parameters for optimising the intensity of cleaning is set (a function of the rotation speed of the opening cylinder (7)), as well as the quantity of waste product is set (which is proportional to the distance between the opening cylinder and the small bars on the grid (8)). The heart of the machine is represented by the group that surrounds the opening cylinder: the presence of cleaning knives with aspiration mouths, the carding segments (9) as well as the option of adopting the cylinder covered with rigid clothing, with spikes or with needles, depending on the type of material being processed. A central aspiration system (10) sees to the continuous collection of waste product, while the fibrous tufts are pneumatically guided to the next machine.

Again with reference to Figure 11, the following can be seen: the aspiration cage (1), the photocells for controlling material flow (2), the reserve chamber or accumulation chamber for cotton tufts (3), the control rollers (4), and the feeder table (6).

The operative principle of the *three-cylinder horizontal opener* (Figure 12) is identical to that described for the single-cylinder horizontal opener, nevertheless the presence of three cylinders, all with a diameter of 275 mm and width of 1,200 mm, but with a different angular speed, that vary progressively from around 1,000 turns a minute for the first cylinder, to over 3,000 for the

last. A pair of photocells (2) regulates the flow of accumulated material in the reserve chamber (3); the control rollers (4) release the right quantity of material and therefore influence the production weight and the degree of opening of the tufts. It is the presence of three opening cylinders and the respective process speed together with the layout of knives on the grid (7), to the carding segments (8) and the deflectors, that permits an intense action even processing cotton containing a high level of trash.

Other elements indicated in the figure are: the aspiration cage (1), the control panel (9), the feeder roller (5), the first opening cylinder (6).

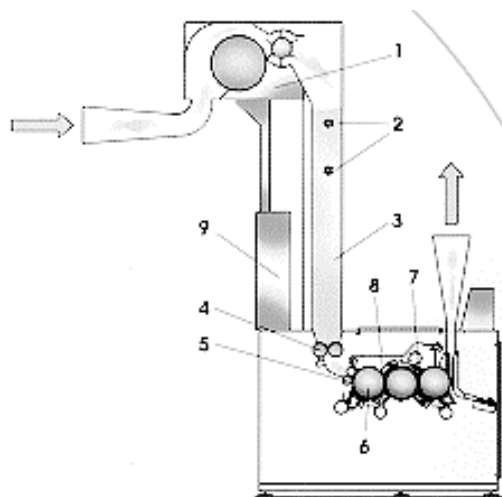
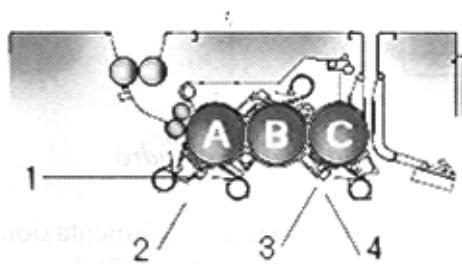

Fig. 12 Section view of three-cylinder opener

The production rate per hour of this opener can reach 600 kg of opened material and the delivery to the feeder hoppers of the card is carried out by a control system, capable of feeding a line of 12 cards (with one or even two blends in process).



In the detailed figure on the left (Figure 13), the flow of material happens from left to right, therefore the following are shown: the three opening cylinders (A is the entry, C is the exit), the knives (1), the aspiration mouths (2), the carding segments (3) and the deflectors (4).

Fig. 13 Detail of the three-cylinder set

Once past the opening and beating stages (Figure 14), the cotton reaches the feeder hopper of the card (8), whose function is to receive the opened material from the opener and deliver it to the card in the form of a regular bulky web, producing at the most 150 kg/h of lap.

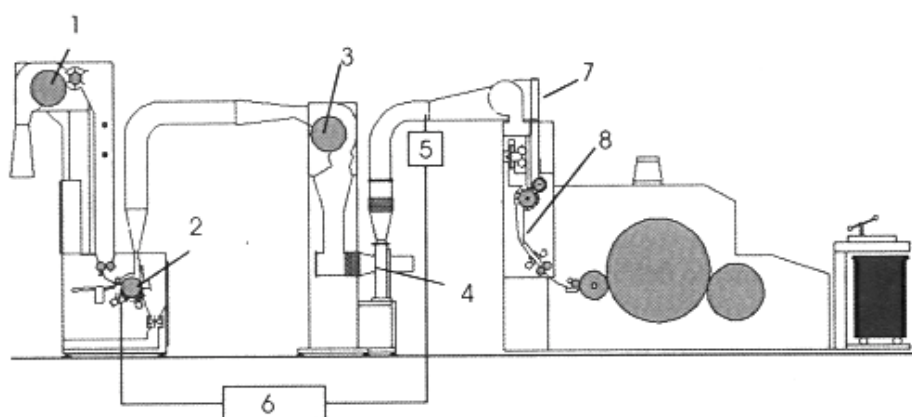

Fig. 14 The linkage between opener and card

The following can be seen in the above diagram: the aspiration cage (1) of the horizontal opener with one cylinder (2), the aspiration cage (3) of the motorised blower (4), the pressure transducer (5) located at the entrance to the feeder hopper (8) of the card, the control unit (6), and the hopper feeder channel (7).

As an alternative to using a conventional motorised blower, above all in the open-end spinning cycle, the use of a specific *dust separator* (Figure 15) is recommended. This is an actual machine that is inserted after the last point of opening and before the card feeder (Figure 16), capable of producing up to 600 kg/h of opened material free from dust and micro-dust. The opened cotton, driven by the motorised blower (1) is taken through the feeder conduit (2) to a special chamber lined with perforated sheet metal (4), which is employed to extract the dust (7) and the waste (8) and it then eliminates the waste through a removal conduit (9). The aspiration funnel (5) gathers the dusted tufts, which thanks to the drive from a second motorised blower (6), again using air pipes are taken to a card feeder hopper.

Figure 16 shows the connection between the opener (2) and the card feeder hopper (8), through dusting (4).

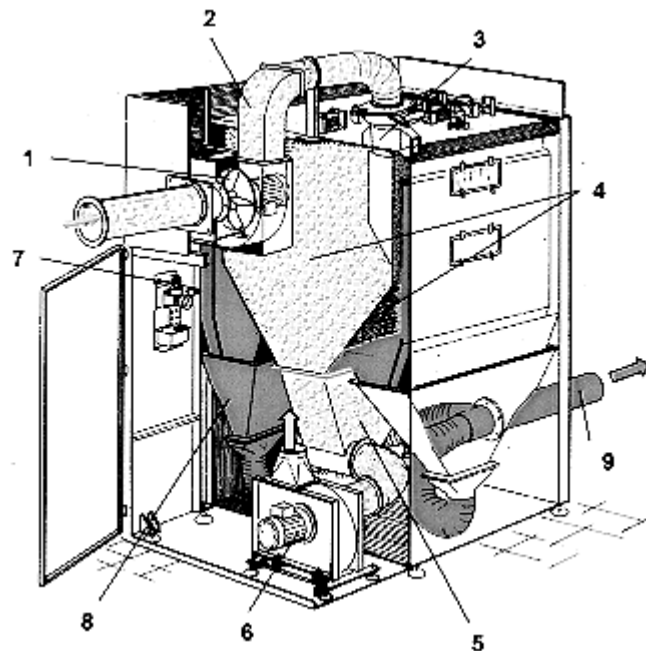

Fig. 15 Cut-away view of the dust separator.

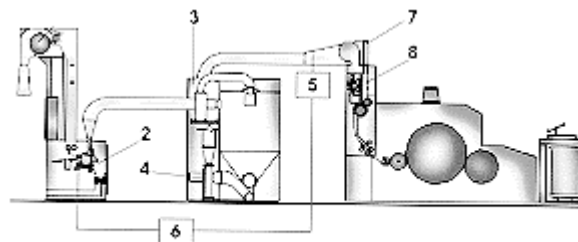

Fig. 16 Linkage between the opener and the card using a dust separator.

The presence of the pressure transducer (5) and the control unit (6) can be seen in Figure 16. The role played by these instruments consists in regulating the flow of material entering the card feeder channel. If the pressure transmitter detects an increase in pressure, it means that the feeder channel is saturated, therefore it commands the production of the opener to slow down or even stop. On the contrary, once normal processing pressure is resumed, the control unit triggers the production of the opener to start up again.

The transportation of the cotton tufts in the air pipe areas of the card feeder system makes use of a two chamber system, with continuous control and regulation of the material contained in the reserve chamber, therefore from the diagram of *card feeder hopper* (Figure 17) it can be seen that in the feeder channel (1) the material is pushed by an adequate air flow and falls (upon request) into the hopper of each individual card incorporated in the carding set.

A special feeder roller (5) takes the cotton tufts from the upper reserve chamber (4) to the opening cylinder (6) where they are suitably thinned out and then transferred to the lower chamber (9), where the lap is formed on exiting the hopper and therefore the count of the lap entering the card is configured.

A transducer (12) regulates the speed of the feeder roller, on the basis of the pressure detected in the accumulation channel (8); the air discharged into the upper hopper chamber (4) goes to a dust extraction channel (2), while the air in the lower chamber is recovered and recycled by the motorised blower (7).

In the figure, the following are also shown: the breaker cylinder (6), the lower air recovery channel (10), the lap plucker rollers (11), and the control unit (13).

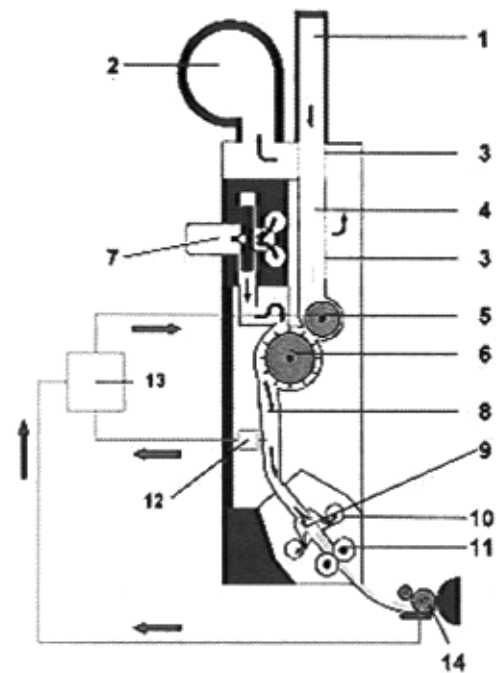

*Fig. 17 Section view of feeder hopper*

The lap exiting the hopper is taken to the feeder roller (14) which is the first (in order of appearance) mechanical element of the card.

# Carding

## General remarks

Carding is one of the most important operations in the spinning process as it directly determines the final features of the yarn, above all as far as the content of neps and husks are concerned. There are many objectives of the carding process and these can be summarised as:

- opening the tufts into individual fibres;
- eliminating all the impurities contained in the fibre that were not eliminated in the previous cleaning operations;
- selecting the fibres on the basis of length, removing the shortest ones;
- removal of neps;
- parallelising and stretching of the fibre;
- transformation of the lap into a sliver, therefore into a regular mass of untwisted fibre.

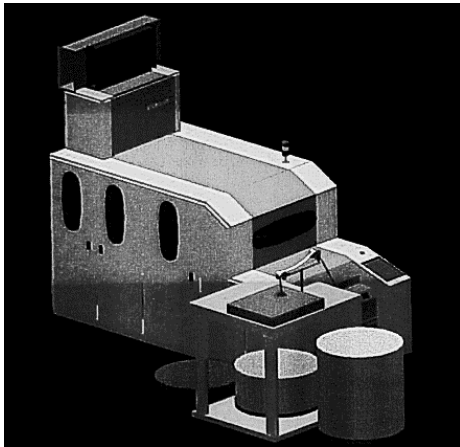

Fig. 18 Card

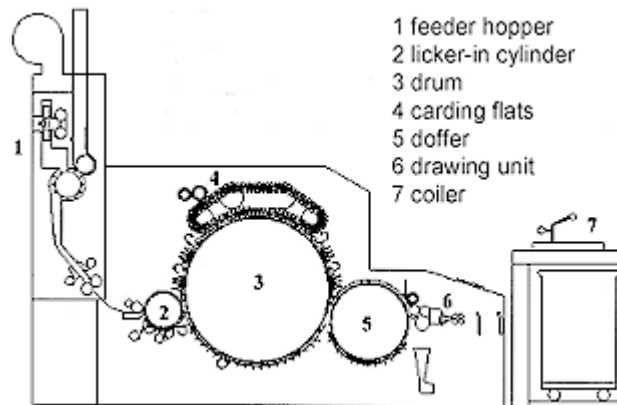

Fig. 19 Section view of the card with hopper

The carding operation is carried out by the *card* (Figure 18 and 19), a machine that in practice is a system of rotating organs, mobile and fixed flats, covered with steel spikes that go by the name of wiring. It is a good idea to know what the wiring and its functions are before going onto a description of the card.

## Wiring and clothing

There are different types of cylinder wiring, in particular:

- rigid wiring, for rotating parts;
- elastic clothing, for mobile flats;
- clothing for fixed flats.

The most common on the machine are the wiring type. They are made up of a steel wire with sharp cutting teeth, the sawtoothlike edge of the wiring is hardened in order to better resist wear caused by the abrasive action of the fibres. The base of the wiring is thicker than the toothed parts, both to guarantee support to keep the teeth in a vertical position, as well as to prevent lateral contact between the teeth and to permit the necessary momentary penetration of fibre into the wiring.

The sizes of the teeth vary notably and depend on how compact the material is, on the quantity and on the fineness of the fibre. The parameters which permit one type of wiring to be distinguished from another are:

- concentration, meaning the number of teeth in a square inch of the wiring (for the various devices of the card the concentration is different and is strictly linked to the type of fibre used; for fine fibre, for example, wiring with a high concentration is used);
- the height of the teeth, which can vary according to the wired element;
- the angle between the teeth and the base in a longitudinal sense.

It is a known fact that a wired element moves in:

- a positive way when it moves in the same direction as the inclination of the teeth;
- a negative way when it moves in the opposite direction to the inclination of the teeth

The fibrous material is found between the two wired elements which, by moving, act on the fibre in an alternate manner: first they trap it then they remove it.

Depending on the layout of the teeth, the direction travelled and the speed of the devices, two conditions are possible, called:

- *carding* position (Figure 20) which is obtained when the teeth of the wired elements are inclined in an opposite direction and their movement occurs with a certain speed and in a direction that permits a reciprocal grasp of the fibre and then the disentangling of the neps and elimination of trash and dust.

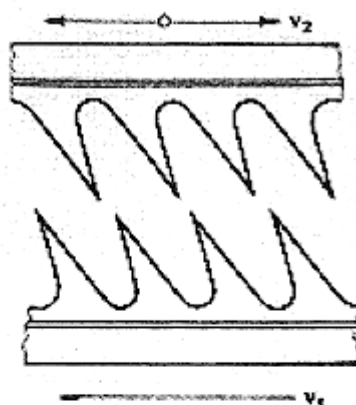

Fig. 20 The carding stage

- position of cleaning or brushing (Figure 21), which is obtained, on the other hand, when the devices have converging teeth and their movement occurs with such a speed and in such a direction to permit the passing of fibre from one organ to another.

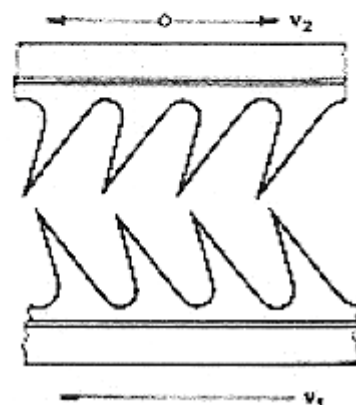

Fig. 21 The brushing stage

## Card

The lap, turned slowly by the conveyor cylinders of the feeder hopper described in the previous pages, is stretched out (Figure 22) onto the feeder table (4), at the end of which is the feeder cylinder (1). The feeder table is made of well polished metal so the fibre is not caught and at the end of it there is a particular spout shape to permit the tooth holding the fibre to get as near as possible to the feeder cylinder.

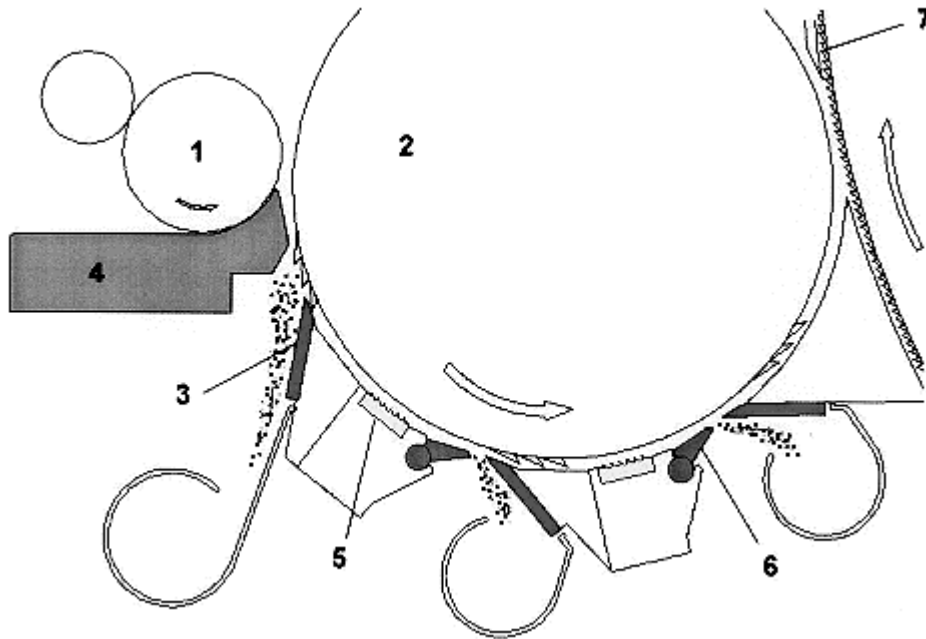

Fig. 22 Detail of the licker-in cylinder

The feeder cylinder, which has a diameter of around 10 cm, is equipped with a slow motor and delivers the fibre to the licker-in cylinder (2) made of light metal with a diameter of between 25 and 35 cm, which rotates in a positive way at high speed, from 400 to 1,300 turns a minute.

The drawing between the feeder cylinder and the licker-in cylinder is around 2,000 times, meaning that a metre of lap fed by the feeder cylinder, becomes 2,000 m on the surface of the licker-in cylinder. The material in this stage reaches a high degree of opening while trash and neps are eliminated. To obtain sufficient opening, it is necessary to respect a theoretical condition, according to which the number of teeth in the entry cylinder which pass in front of the feeder table, must equal the number of fibres fed at the same time. The ratio between these two sizes, in the unit of time, is defined as the *intensity of carding*. Therefore, to increase the intensity of carding, the quantity of fibre entering and vice versa must be reduced. The licker-in cylinder is equipped with rigid wiring with large and resistant teeth.

The grill and knives on entry are very important factors for obtaining good opening and cleaning of the material. As evident in Figure 22, the grill is made up of three parts: an initial plate with knife (93), a section with triangular section teeth (5), making up the fixed flat, finally, a third section with a continuous plate (6). As well as helping clean and select the fibre, it permits the recovery of tufts of good fibre that eventually come away from the licker-in cylinder, and it moves them nearer to the exit; in particular when the amount of waste is determined by the position of the continuous plate compared to the cylinder teeth.

The function of the licker-in knives is to eliminate any large impurities that the cylinder has brought with it. They are made up of steel rods with trapezoidal section with sharp tips, inclined in the opposite direction to the licker-in cylinder teeth, in order to force the material through a violent impact and therefore release foreign matter and neps which usually, being heavier than the fibre, protrude more than the wiring, and they collect the material left protruding from the continuous plate. Immediately after the entry cylinder there is a drum (7). This consists in a large-diameter cylinder, around 130 cm, in cast iron and generally cast in a single piece for better solidity and to prevent deforming. After the casting, the drum is stress-relieved in an oven or left to harden outside for some months, and then it is turned, ground and balanced. The drum is equipped with rigid and thick wiring, it turns positively with a peripheral speed which is almost double that of the licker-in cylinder (therefore between the two elements there is a two times the drawing action) and it follows the same cleaning phase as it.

There is a grill beneath the drum to help eliminate the short fibre and prevent the fibres generated by the high centrifugal force as well as air currents caused by the rotary action of the drum from being dispersed. In order to complete its function, the grill is eccentrically positioned, with a higher distance at the entry. The grill can be made up of small bars or in some cases perforated sheet metal. The drum can reach a speed of 500-600 rpm. It is also possible to verify that with the increased speed of the drum, the particles of trash in the card sliver are reduced. Nevertheless, it has been noted during laboratory tests that this correlation has an asymptotic trend towards a maximum value, meaning a further increase in speed, for example an increase from 400 to 500 rpm does not lead to any significant progress in cleaning the card sliver.

The drum speed is important also as it concerns another two parameters: the number of fibres present in the drum and the defibration of these. As far as the first is concerned, with other conditions on a par, the higher the increase in speed, the more the fibre density is reduced. While for defibration, on the other hand, it increases to an extent that is more proportional to the increase in drum speed. Above the drum there is a series of plates called mobile flats, whose depth is equal to that of the drum.

## Flats

In the past, mobile flats (Figure 23) were made up of cast iron bars, with a T-shaped section providing a robust rib in the centre in a longitudinal direction, to prevent deformation. Nowadays, the rib is made from an aluminium alloy, that increases resistance to deformation and is lighter. Semi-rigid clothings are fixed at the base of the flats; these are connected to each other by special chains (Figure 24-2) and their extremities rest on special arches fixed to the shoulder of the machine. The distance between flats and the drum is reduced towards the exit (on the right looking at the diagrams in Fig 23 and 24), in order to gradually disentangle the fibres; their motion can be either positive or negative (depending on the solution chosen by the manufacturer) but it is, however, a very slow process depending on the intensity of carding desired; if the speed is increased, the quantity of waste rises too.

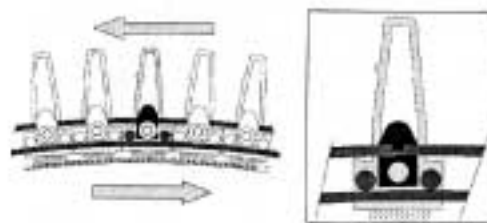

*Fig. 23 Detail of the flats*



The level of the needles on the flats is not parallel to that of the drum, but it forms an angle of around 1.5 degrees, as the fibres would be gripped almost exclusively by the front rows of flats, resulting in a reduction of the carding surface and rapid wear on the needles. Therefore, the inclined positioning of each flat permits uniform working by all the needles and a gradual hold on the fibres that are raised by the centrifugal action between one flat and another.

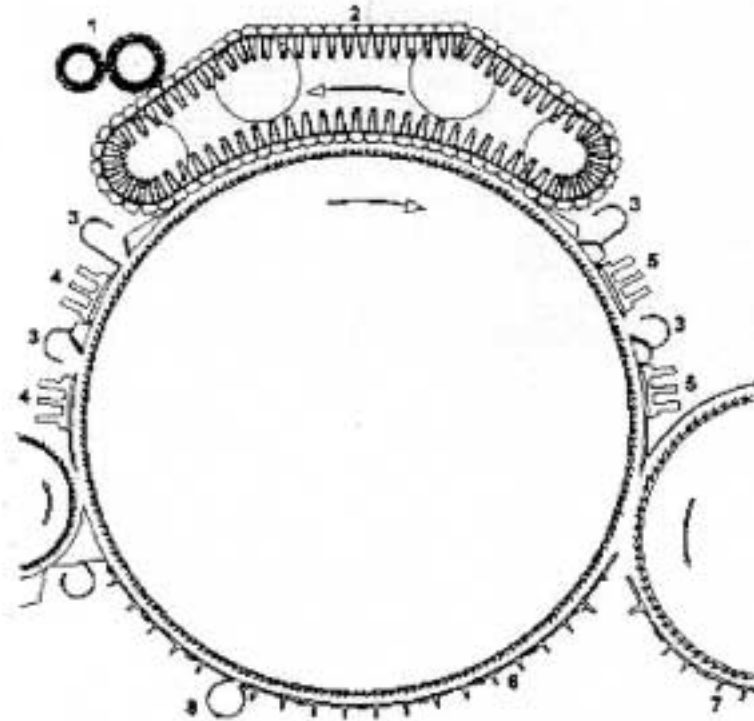

*Fig. 24 Detail of the drum area*

It can be noted from Figure 24 how each flat can be in a work or rest state. In the first case, the drum teeth and the flat needles face opposite directions and therefore this is the true carding stage, while in the second case the flats have needles pointing upwards.

An oscillating comb is employed to clean the flats removing the waste accumulated on the flats needles, and the comb is aided by a rotating brush (1) covered by very long curved needles, which penetrates into the wiring of the flats carrying out thorough cleaning of residue waste.

Between the licker-in cylinder and the entry to and delivery of the flats and the doffer cylinder, there are some fixed flats (4 and 5) and respective cleaning units composed of cleaning knives (3) with a mouth for continuous aspiration, which provides a good dedusting effect. The fixed flats have the function of increasing the carding action, so improving the quality of the card sliver. In modern cards, in order to obtain a trouble-free working even with sticky cotton, special aluminium plates are used (6 and 7) as is direct aspiration of the card waste (8). All the carded fibres from the drum then pass to a doffer cylinder, which is covered with wiring similar to the drum, being very dense. The peripheral speed of the doffer cylinder is lower than that of the drum, therefore between the two a process of condensation occurs. To permit the fibre to be collected as a uniform web, the doffer motor rotation is negative while between it and the drum a carding action takes place.

From what has been described, the passage of the fibre from the drum to the doffer cannot take place. It is, on the other hand, possible for the following reasons:

- the teeth in the doffer cylinder are always clean and therefore the passage of the fibre from the drum to the doffer can easily take place;
- the closeness between the drum teeth and the doffer permit the latter to get a grasp on the fibres;
- the centrifugal force, generated by the high speed of the drum and the air current, tends to remove the fibres from the drum teeth, taking them towards the surface of the doffer;
- the longer length of the doffer teeth compared to the drum teeth means that fibres are gripped by the first;
- two organs in a carding position in relation to each other operate a reciprocal exchange of fibre.

During the passage of fibre from the drum to the doffer cylinder, various fibres curl and behave like short fibres. These curls can be at the tail end if the fibre is folded in a direction opposite to the movement of the material, or at the tip if the opposite is true. This defect will be eliminated later, by drawing and eventually by combing. Analysis of laboratory trials show that mainly tail curls emerge from the card.

The web that forms on the doffer is removed in a continuous manner, by wired extractor cylinders which, rotating in an opposite direction to the doffer cylinder, are able to pluck the fibres and condense them in a web.

The latter is picked up, passed through a pair of smooth steel cylinders and through two flat belts, and accompanied into a conveyor funnel, which condenses the web turning it into a sliver. The sliver is pulled by a pair of cylinders. The lower ones are steel and have longitudinal furrows, while the upper ones are covered with rubber and are maintained pressed against the lower ones. With this pair of cylinders, the drawing operation takes place, increasing the parallelisation of fibres. The fibres are drawn no more than two times in this area. On delivery from the drawing unit, there is a system to control the presence of the sliver, and this system will stop the machine immediately if no sliver is detected.

The next sliver passes through another funnel and is distributed in a can by a special device called a coiler, composed of a pair of rollers (necessary for pulling and moving the material forward), of a condensation funnel carried by a plate equipped with a rotary motor (to distribute the sliver in the can in overlapping coils). Inside the can there is an aluminium or plastic plate, supported by a spring which serves to maintain the distance between the distribution plate and the sliver delivery point constant, in order to reduce the occurrence of false drafts in the section of sliver between its delivery from the coiler and the bottom of the can. In fact, as the material is deposited on the plate, the spring is compressed. While the sliver is unwinding from the card, the spring carries out the same function described, but in the opposite way, thus supporting the sliver upwards.

### **Automatic cleaning of the card**

As the card produces a notable quantity of dust, it is necessary for aspiration by a pneumatic system to be continuous, equipped with recovery mouths, which can suck out contaminated air from various points of the machine and take it to the central conditioning system.

The main air removal points are:

- between the cylinder and feeder table and the licker-in cylinder;

- between the working flats;
- between the doffer and the removal cylinder;
- beneath the licker-in cylinder, the drum and the doffer.

As far as the discharge of impurities is concerned, this procedure is carried out regularly by the machine's central aspiration system both beneath the licker-in cylinder as well as in the flats.

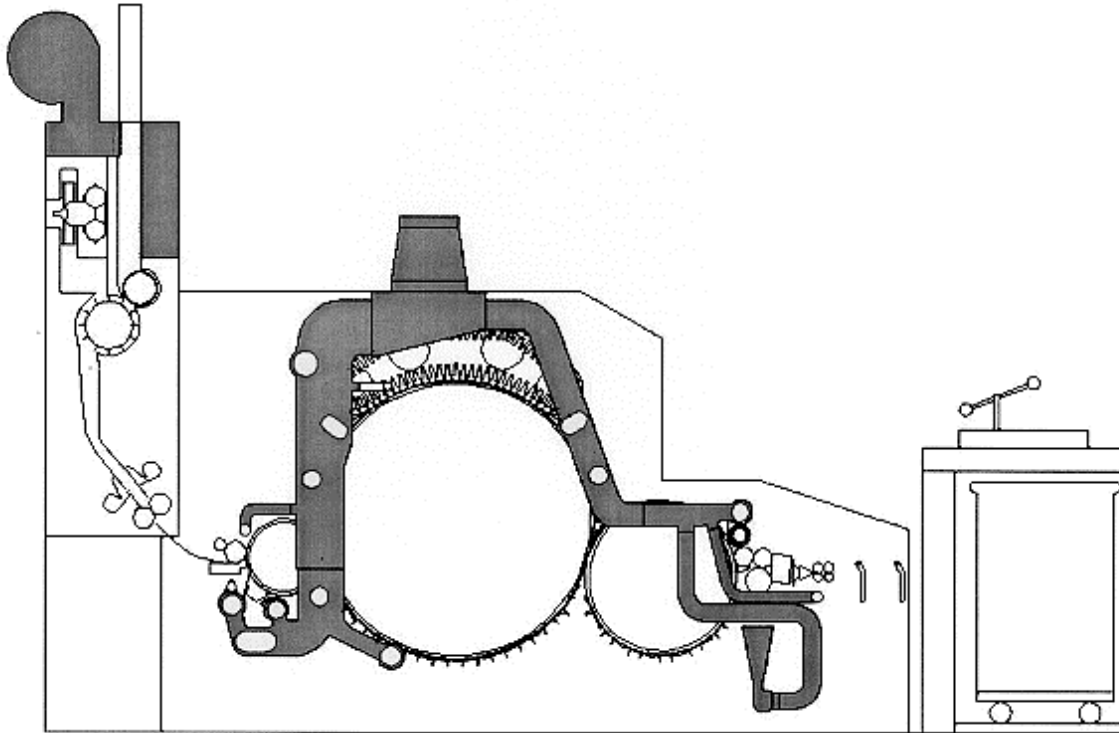

*Fig. 25 The automatic cleaning system.*

### **Sliver count autolevelling**

The card sliver usually presents some variations in count (long-term irregularities) due mainly to the section of entry lap. Less frequently, sectional irregularities on short lengths of sliver are generated (the so-called short-term irregularities).

These are eliminated by the doubling of slivers on the drawframe.

A device called a self-regulator is used (Figure 26) to highlight the variations in count on the card. By varying the drawing action of the machine on the basis of the variations in the section of material, the device permits slivers to be obtained with maximum evenness.

The autoleveller is composed of:

- a measuring device which controls, on entry or on delivery, the section of fibrous mass being worked and sends signals with proportional intensity to the measured section;
- an electronic apparatus that processes and recognises the data sent by the measuring device and, if the difference between the measured value and the desired value is greater than the preset tolerance level, it sends electrical impulses to the draft variator;

- a speed variator controlling the movement of the autoleveller, that carries out the variation of the machine draft on the basis of the section of material controlled.

Depending on the position of the measuring and levelling devices, there are closed loop autolevellers when the measuring device is placed before the autoleveller or on open loop autoleveller when the contrary occurs.

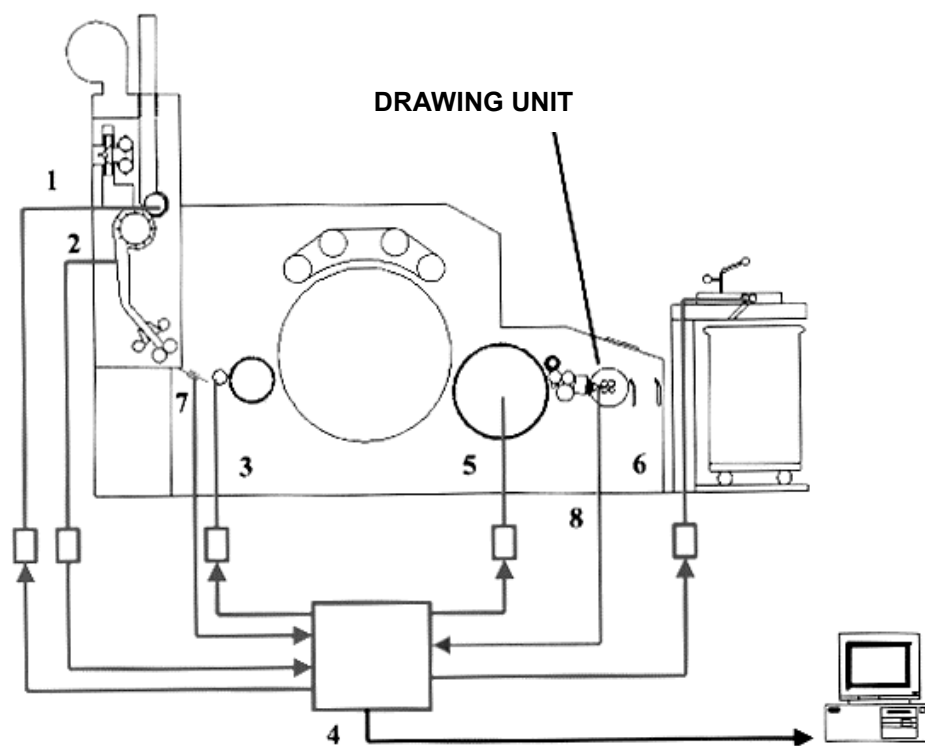

*Fig. 26 An autoleveller for medium-period defects*

- 1 Hopper feeder cylinder
- 2 Analogue pressure switch
- 3 Card feeder cylinder
- 4 Microcomputer
- 5 Doffer
- 6 Coiler
- 7 Lap thickness sensor
- 8 Funnel with monitoring sensor for quantity of sliver.

## **Recycling process waste**

As a consequence of the spinning, weaving and knitting of the cotton and short-staple fibre being carded, combed or open-end spun, working of regenerated fibre has sprung up where regenerated fibre is intended as knitting waste, sub-products derived from the spinning cycle (flying fibres), the waste, the scraps from weaving (cut selvages and so on).

Since the 1980's, this type of fibre has been recycled thanks to the conventional carded spinning system: they were in fact worked in sets of two or three cards and then spun on conventional ring spinning frames).

With the diffusion of open-end spinning frames, these fibres are now worked with the new technology that in just a few years has completely replaced conventional carded spinning.

The work stages of the cotton scraps have therefore become:

- unravelling of the hardest materials (knitted scraps, cut selvages, flying fibres)
- beating of waste
- blending with virgin materials
- carding with a system dedicated to cotton fibres with the need to parallelise and open the fibres that are much shorter and opened to a much lesser degree with the lowest amount of waste possible.
- doubling and drawing (cotton drawframe). Essential for obtaining finer counts, this is inevitable in the case of coarser counts through the application of an autoleveller on the card and direct passage to the spinning frame.
- open-end spinning frame, fed directly by the card or the drawframe depending on the finished product.

The cards for regenerated cotton and for very dirty cotton must open and clean what cannot be opened in the preparation stage and must lead to the lowest percentage possible of waste, this type of fibre being extremely difficult to recycle a second time.

As can be seen from the diagram attached (Figure 27), these cards are equipped with a pre-opening unit made up of a pre-carding cylinder (diameter 700 mm) with a series of fixed flats with ordinary clothing. It is the task of this cylinder to pre-card the fibres.

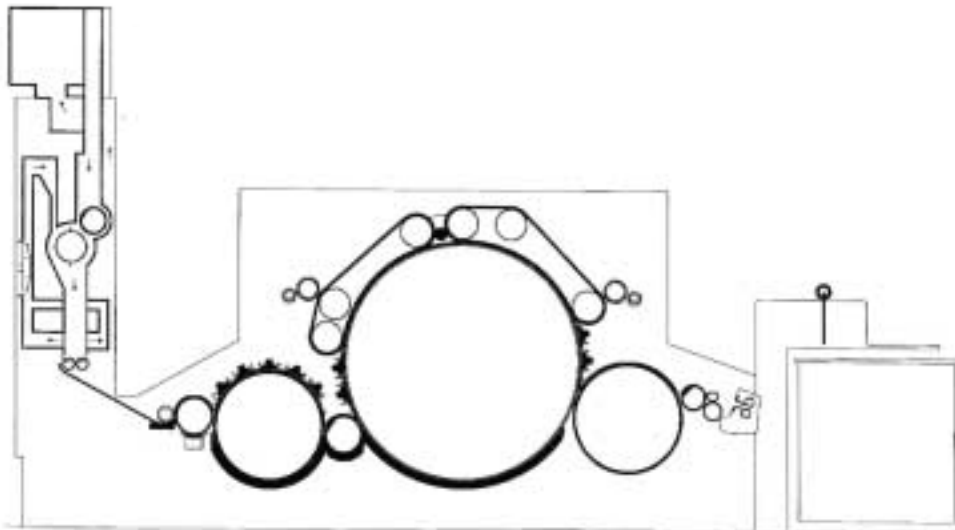

*Fig. 27 Card for regenerated cotton*

These cards have a main cylinder with a diameter wider than that of a conventional cotton card (1500 mm) which permits the application of a double set of flats (64 flats on drum entry side and 70 on delivery side) which permits a high carding action and improves the cleanliness of material on exit.

The drum speed varies from 300 to 450 rpm, while the flats vary from 100 to 400 mm a minute. The speed of both the drum as well as the flats are variable to make developing the carding in function of the type of the materials used easier, bearing in mind that the fibres in this sector are very inhomogeneous. Machine aspiration is only employed to evacuate the dust that is generated during operation.

A single waste knife for coarse material is applied on entry to the licker-in cylinder. Flats fixed on the drum both on the entry as well as delivery make parallelisation of the fibres distributed on the drum easier and as a consequence permit them to be cleaned and opened. Once the material is carded, it is condensed on the combing machine and it is conveyed by two transversal belts (indispensable for this type of working) that transport the web coming out of the web doffer in a funnel.

For carding operations immediately preceding the open-end spinning stage, on each card a sliver autoleveller is applied which, acting on the delivery speed of the sliver, and eventually on the material entry speed, means the variations in count on the sliver can be reduced.

In working materials involving passage through the drawframe (not possible with very short fibres or ones that are difficult to draw in a uniform manner) the evenness of the sliver fed to the spinning frame comes from both doubling the slivers from different cards as well as the autoleveller of the drawframe itself.

The passage through one drawframe (when possible) also permits the doubling of slivers from different cards and guarantees on the final sliver a perfect homogeneity not possible in the case of a direct passage.

On the basis of these considerations, open-end spinning of regenerated fibre permits a yarn to be obtained that reaches a maximum count of Ne 5 in the case of direct spinning after carding and yarns up to a count of Ne 20 in the case of passage through the drawframe.

When working with very dirty cottons and cotton waste, the card (having the structure that has been indicated) is equipped with additional aspiration points (under the licker-in cylinder and the main drum) so that it can remove as many impurities as possible from the material.

## **Doubling and Drawing**

In preparing the fibre tufts for spinning, doubling and drawing represent two essential operations and their combined effect permits a sliver with a more regular section to be obtained (through doubling) equipped with parallel fibres (through drawing) as well as the count requested by the spinning plan.

The drawing operation done with the machine called the drawframe (Figure 28), permits a homogeneous blend both with fibres of the same nature as well as fibres with a different nature; the doubling steps are usually between four and eight.

On a par with fibre characteristics such as length and fineness, a sliver with parallel fibres permits a yarn with better regularity and resistance. The drawing depends on some factors such as the number of doublings carried out and the value of the count of the entry sliver and delivery sliver. With drawing, curls are also eliminated, meaning the fibres folded in on themselves, present in the carded sliver.

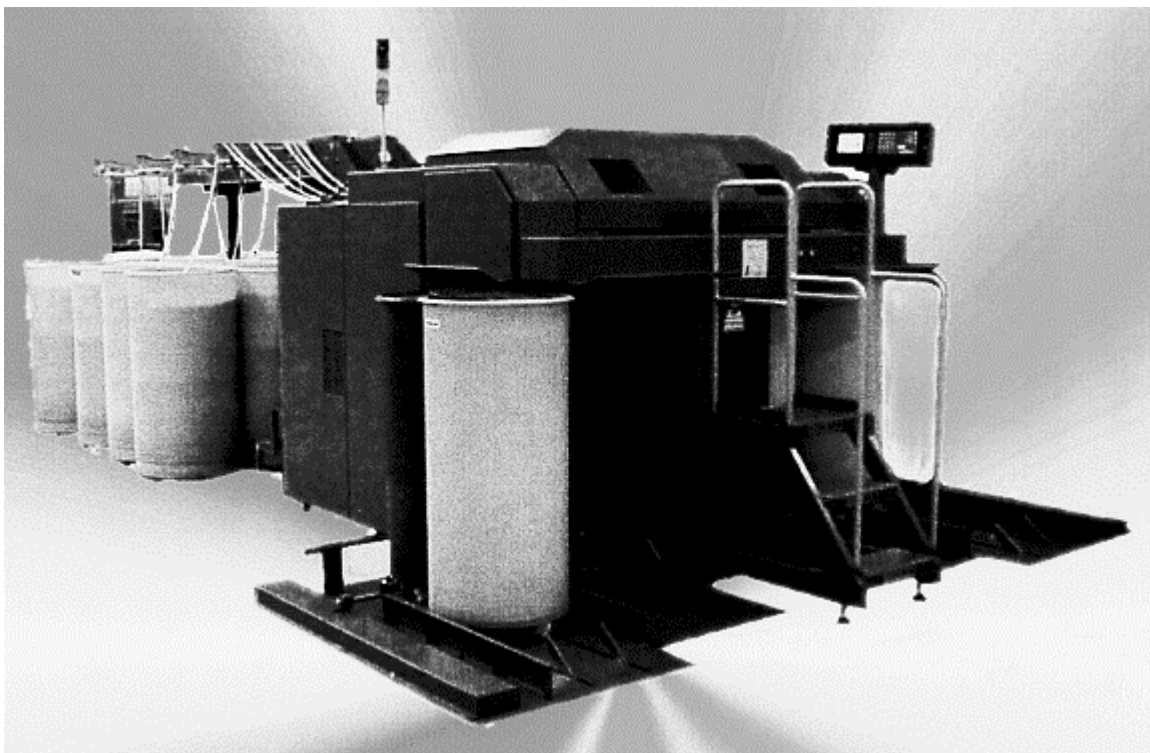

*Fig. 28 Drawframe*

### **Drawframe**

The cans that contain the sliver are placed along the drawframe feeder rack, usually including eight pairs of cylinders (each pair is above the space occupied by a can): the lower cylinder is commanded positively, while the upper one rests on the lower one in order to ensure movement of the relative sliver that runs between the two.

Supported by the feeder rack, the slivers are pulled by the drawframe entry cylinders, which they join guided to lay beside each other on a well polished table. The system described notably reduces the so-called false drafts, which the slivers can be subject to. The false drafts occur when material of little consistency, such as the sliver or roving, is lengthened and is subject to excessive friction or unusual tension during the passage from one machine to another (but also on the same machine). The occurrence of false drafts depends therefore on the distance between the delivery or unwinding point and the material pull point, as well as on the smoothness or fluidity of the support and guiding parts.

Another important action taken to avoid false drafts, as mentioned above, is the use of cans with spring plates, using which it is possible to maintain a minimal and constant distance between the point the sliver unwinds and the pull cylinders.

## **Drawing aggregate**

The *drawing aggregate* is composed of a series of lower cylinders called draft cylinders, below a series of upper cylinders with rubber sleeves called pressure cylinders.

The draft cylinders consist of single-piece steel bars or bars made up of perfect fitting sections; they must be perfectly cylindrical and have longitudinal grooves, so that the fibres can be grasped in the tangent point with the pressure cylinders and later come away easily, without getting tangled up.

The grooves can be either of two types: parallel or helical.

The draft cylinders have various support points in order to prevent them from or limit their bending and they glide on rolling bearings on the supports. It is important that the right diameter is chosen, as when the diameter is increased, the following occurs:

- 1) the lower cylinders travel at a slower angular speed and consequently there are fewer vibrations and less wear on the bearings;
- 2) the gripping arch of the cylinders is increased, permitting better control of the fibres;
- 3) the pressure of the upper cylinders is reduced and therefore there is a lesser load on the draft cylinders providing for a longer life of the covering, less wear on the bearings and a lower energy consumption.

The pressure cylinders are also made in steel and are covered with rubber sleeve; they have support pivots at their ends that fit into the special guides, establishing the position of the cylinders and providing the connection with the relative loading devices. The rubber sleeve must:

- provide excellent grip on the fibres, but at the same time it must offer a long life;
- resist the abrasion effect produced by the fibre and the draft cylinder;
- be elastic to the point of being able to recovery its original form after having been crushed on the draft cylinder;
- be non-adhesive in order to repel substances such as enzymes, wax, and sugar which tend to remain on the surface of the cylinder, interfering with the normal working process;

On the cylinder pivots, a certain load is applied, which permits a harder or less hard crush against the corresponding draft cylinders. The so-called load is exerted by air or spring pressure devices.

The pressure conferred can be subdivided into absolute or relative.



The former is obtained when maximum pressure is exerted on all the fibres that are between the cylinders, so the fibres assume the peripheral speed of the relative draft cylinder. The second is actuated when a simple control is carried out on the fibres being drawn, so that they can glide between the pair of cylinders without breaking, they are guided and accompanied and therefore do not float.

The uniformity of the drawn sliver also depends on the gauge between cylinders, meaning the distance between two adjacent cylinders on a drawframe. An incorrect gauge leads to a great quantity of floating fibres and therefore irregular sections. The gauge will depend on some factors such as: fibre length, the quantity of fibre to draw, the entity of the draft in the relative area (called partial draft), the degree of pressure from the cylinders in question, and the degree of parallelisation of the fibres. Generally the gauge increases as these values do.

As far as floating fibres are concerned, it is important to emphasise how the draft value essentially depends on the number of fibres present in the fibrous mass to be drawn.

In a draft zone, the fibres can be found in three positions:

- held by the pair of entry cylinders and then advanced slowly;
- held by the pair of delivery cylinders and then made to travel faster;
- loose, meaning fibres that are in the central part of the draft zone which shorter than others and not parallel, these are not held by either pair of cylinders.

If the loose fibres follow those held, problems will be avoided as they will then be gripped by the pair of delivery cylinders and then drawn accordingly. If the loose fibres follow those held by the pair of delivery cylinders, the fibres will float, meaning that the fibres will travel through the draft zone at a higher speed than the speed required for a normal draft, taking them further forward than where they should be. Therefore, with their irregular and periodical movement, these loose fibres give rise to what are known as draft waves.

Floating fibres cause lengths of sliver with variations of section that can be fine (referred to also as cuts) or coarse. The number of these defects is proportional to the number of floating fibres and the frequency of the waves.

The drafting set mounted on the drawframe can be divided into two categories:

- systems composed of three pressure and four draft cylinders;
- systems composed of four pressure cylinders on five draft cylinders, with an intermediate draft cylinder with a smaller diameter than the others and with pressure bar.

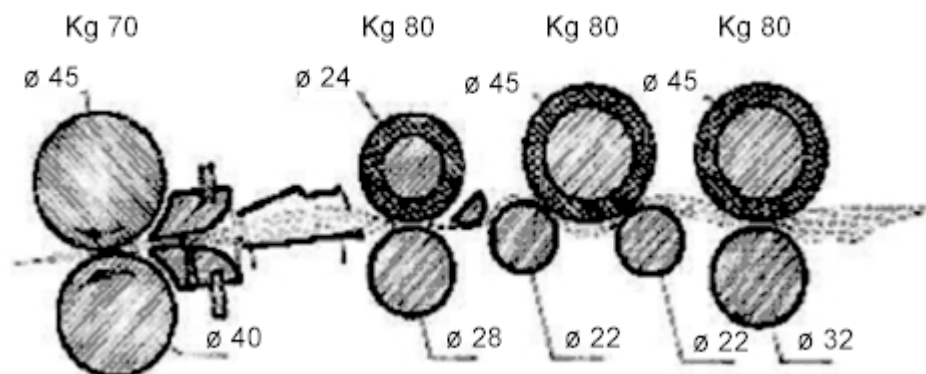

*Fig. 29 Three- cylinder drafting unit on top of 4, with pressure bar*

Pressure bar systems (Figure 29), used essentially when working with blends made up of fibres of different lengths, have a 3 pressure and draft cylinder unit and a cylindrical bar that does not roll called the pressure bar, located between the first and second pressure cylinder and connected directly to the latter by small arms at the ends. Therefore, it is located above the fibre band and it presses down while the fibre is travelling through the delivery area (area where maximum draft pressure is applied), forcing the fibres to adhere to one another. In this way the fibres are checked and well distributed during the draft, creating even slivers even at high speeds.

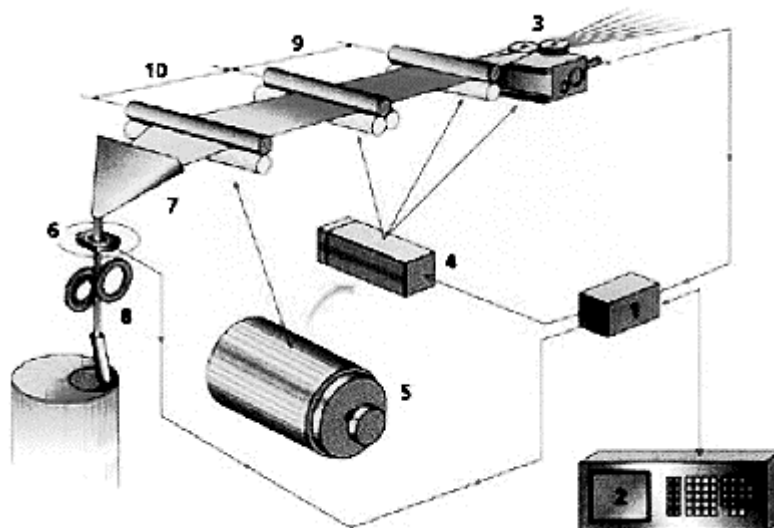

*Fig. 30 Drawframe autoleveller*

- |                       |                     |
|-----------------------|---------------------|
| 1 Autoleveller module | 6 Monitoring sensor |
| 2 On-board computer   | 7 Web condenser     |
| 3 Measurement unit    | 8 Delivery rollers  |
| 4 Servomotor          | 9 Pre-drawing       |
| 5 Main motor          | 10 Main draft       |

Like on the card, there are also autolevellers on the drawframes (Figure 30), whose job it is to correct the draft in function of variations in the fibrous mass, to maintain the section of sliver as even as possible and therefore reduce the frequency of breaking threads in spinning and in successive operations.

On the drawframe, the variations in sliver mass are detected by a measurement device (3) composed of scanning cylinders, and they are compensated for by a variable draft driven by a digital processor and a speed variator which drives some draft cylinders.

It is possible to obtain the following values on the drawframes:

- total machine draft, this can vary from around 6 to 9 times and usually affects the delivery area, where a partial draft of between 4 and 7 times is completed;
- partial entry draft, this can vary from around 1.2 to 1.8 times and affects the entry area between the last and next to last cylinder;
- the tension draft for slivers entering the pull cylinders and the entry cylinders of the drafting unit oscillate between 0.9 and 1;
- the web tension draft, between the delivery cylinders of the drafting unit and the pressure rollers, can vary between 0.9 and 1.

## Combing

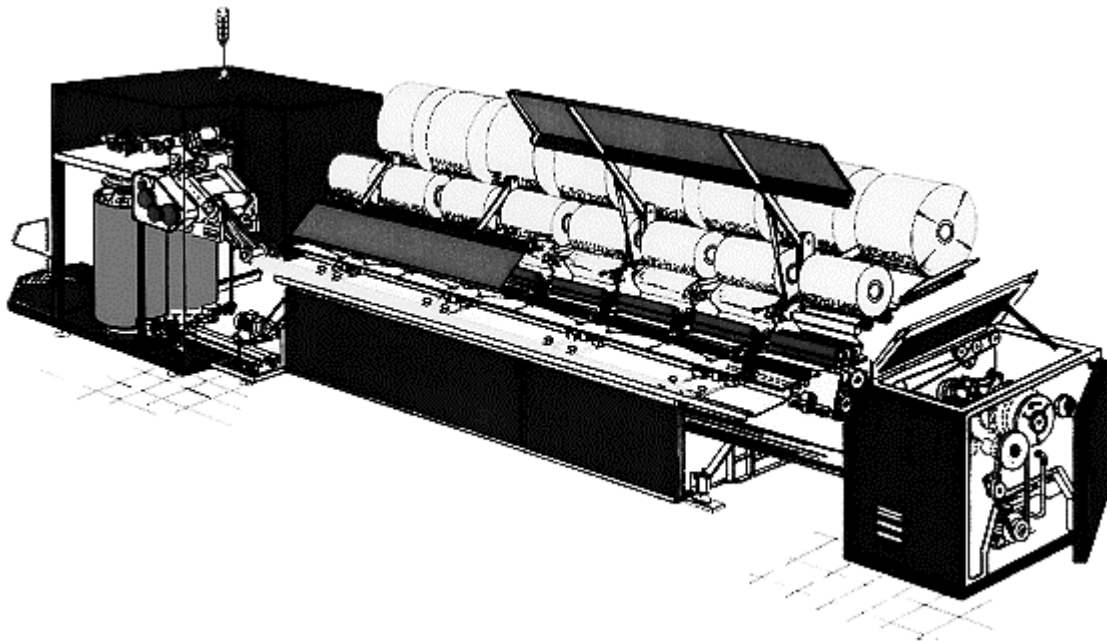

*Fig. 31 Combing machine*

The combing process is carried out in order to improve the quality of the sliver coming out of the card. The process eliminates short fibres, it achieves better parallelisation of fibres, it straightens curls, and it removes neps and residue impurities. It is clear from these functions that the combing process is essentially aimed at obtaining excellent quality yarns and to fulfil this objective raw materials with above average physical and mechanical features must be used from the very beginning of the spinning process. Depending on what is being produced, waste from combing varies from 12% to 25%, and this can be employed to obtain yarns with a medium-coarse count using the open-end process.

As far as parallelisation of curls is concerned, when curls are combed they tend to behave in a very similar way to short fibres and therefore if they do not straighten they are removed, and this produces a notable amount of waste fibres; it is therefore necessary to reduce the curls before the combing stage. Some of the “curls” straighten when drawn in the combing preparation stage. Furthermore, it is a good idea for the curls to be presented head first to the combing machine, as the latter are to a large extent straightened by devices on the combing machine. The direction of the curls depends on the number of passages the material is subject to following carding, as between one passage and another the direction of the material is inverted and consequentially the curls are too. Therefore, considering that mainly tail curls come out of the card, in order for them to arrive at the combing machine as head curls, it is fundamental to carry out an even number of preparation passages, usually two, one to the drawframe and one to the lap drawing frame.

The lap drawing frame has, furthermore, the task of forming the interfacing, which is employed to feed the combing machine. The interfacing is obtained by doubling a certain number of slivers (from 16 to 32) previously subject to a drawing passage. In the lap drawing frame, the material undergoes a light draft of around 1.5 to 2 times one a drawing aggregate of the type 2 on top of 3 cylinders.

## Combing machine

The combing machine is composed of eight combing heads which produce slivers which, later, are doubled four on four by a drawing aggregate of four on top of five cylinders to make two slivers which are taken to the collection cans. Each combing head is composed of feeder rollers which hold the web and rotate it perfectly, without varying the structure. The rollers rotate slowly with continuous drive and bring the web forward to a combing unit made up of special nippers (Figure 32) which must hold the fibres during the combing stage and take them to the device which gathers the tufts.

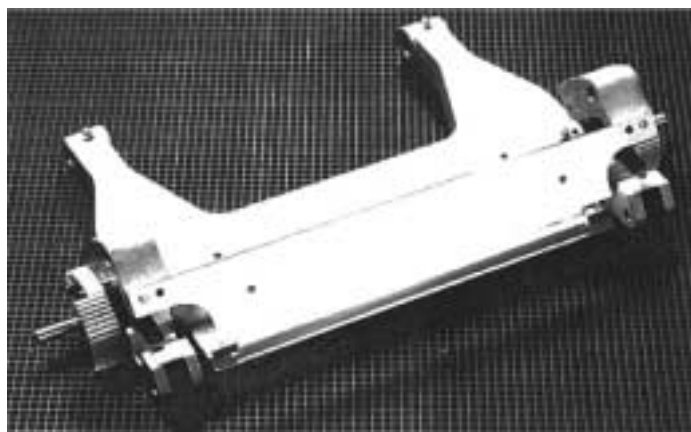

*Fig. 32 Combing machine nipper*

The nippers are formed of two square aluminium plates, called “lower jaw” and “upper jaw”. The first acts as a feeder table for the web, while the second holds the tuft. During the combing cycle, the nipper has an alternating movement, it can be all the way back and closed to hold the fibres during combing or in an all-forward open position to favour the separation between the combed tuft and the advancing web. The feeder cylinder is located above the “lower jaw”. It follows the movements of the “lower jaw”, it rotates intermittently, drawing the web forward a certain distance at each stroke of the combing device. The feeding can take place in one of two ways: feed with nipper moving forward or backward. From empirical trials, it has been established that backward feeding offers better benefits in terms of separating waste and in the combing effect.

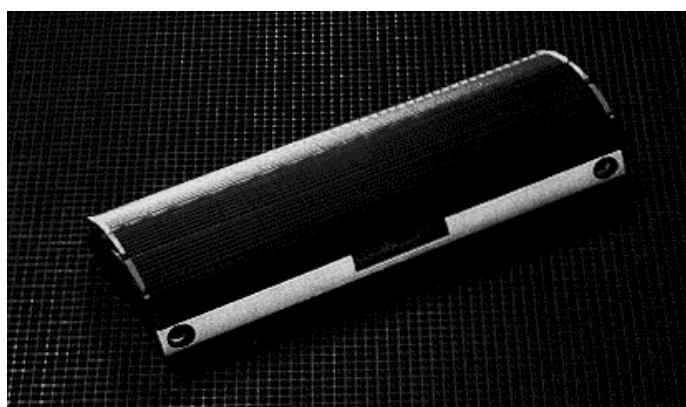

*Fig. 33 Circular comb*

The combing element takes the name of circular comb (Figure 33). It is without a doubt the most important device on the machine, it is composed of a circular sector covered with needles covering around a quarter of its circumference and the density of its needles differ from the first lines to the last. The circular comb turns quickly in a positive direction and the needles, penetrating the tuft of fibre to comb, remove the fibres that are not clasped by the nippers, and parallelise the others. The circular comb completes around 200-250 rpm. To eliminate the fibres caught, a cylindrical brush penetrates the needles on the circular comb removing all the waste and an air current removes it, taking it towards the collection bins before the next combing stage begins.

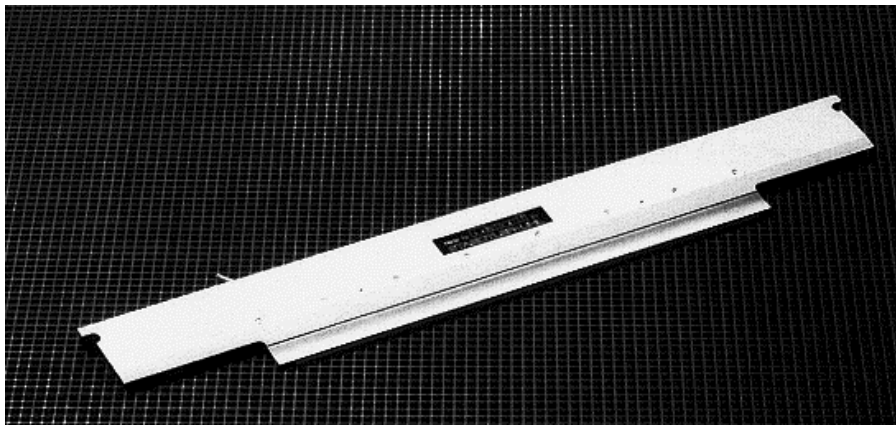

Fig. 34 Linear comb

The fibres which are clasped in the nipper following the passage through the circular comb, are again combed by the linear comb (Figure 34). This is made up of a bar covered with very dense needles positioned almost vertically between the nipper and the device that allow the tuft to travel forward.

The task of the linear comb is to straighten and therefore parallelise the fibres folded towards their tail ends and pick out the folded fibres, letting past those successfully combed and holding back the others which will later be combed. The device that takes the combed tufts forward is made up of two pairs of small diameter cylinders which are called drawing off cylinders. The upper cylinders are covered with rubber, the lower ones are grooved metal.

They rotate alternatively and intermittently in the two directions, in order to remove the combed tuft from the small lap and condense it with the previous one, giving rise to a continuous fibre web. Initially they rotate in a negative direction bringing back a section of the previous tuft, then in a positive sense overlapping the latter with a part of the tuft, which is then drawn off by the small lap, drawn and brought forward a certain degree.

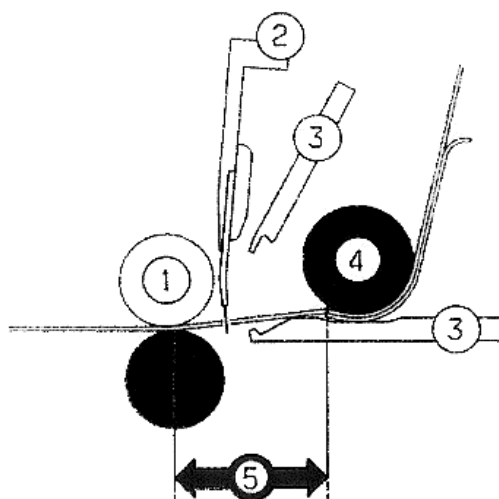
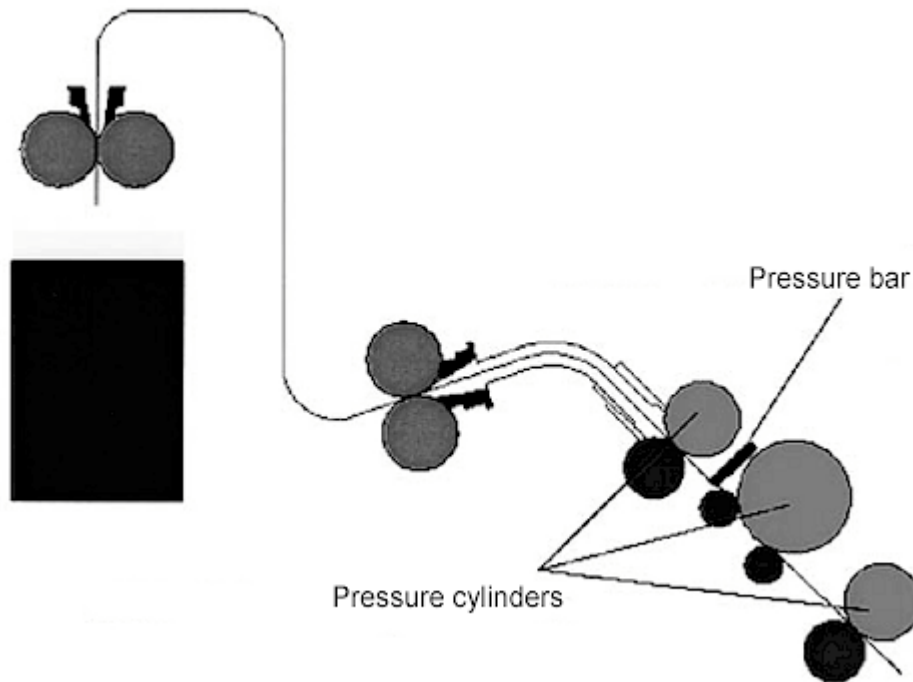

Fig. 35 Detail of a combing machine

- 1 Drawing off cylinders
- 2 Linear comb
- 3 Nipper (upper-lower jaw)
- 4 Feeder cylinder
- 5 Tuft.

The fibrous material comes out of the drawing off cylinders in the form of a web, and this passes between one pair of cylinders, whose task is to provide the necessary consistency, to then pass into a condensation funnel and the small rollers which transform the web into a sliver. The latter is dragged on a very smooth table to prevent any friction, it turns ninety degrees and is taken next to the slivers coming out of the other heads of the combing machine.

At the end of the table the slivers enter a drafting unit, very similar to the one on the drawframe, and are doubled and drawn to obtain the combed sliver, which is then taken by the rollers and the distribution plate to the collection can.



*Fig. 36 Detail of the drawing aggregate*

### **Combing stages**

The devices on the combing machine are well synchronised with each other and a combing cycle is completed in the time it takes the circular comb to complete one turn. This cycle is divided into three stages:

- 1) combing of the tuft
- 2) backward motion of the previous tuft
- 3) condensing of the tufts.

The movements of the devices on the combing machine are as follows:

1<sup>st</sup> stage: the tuft is combed

The nipper moves backwards and closes, leaving a section of fibrous material protruding and this is the tuft to comb. The length of the tuft is around 10-15 mm and is given by the minimal distance between the nipper and the drawing off cylinders plus the section fed. The circular comb penetrates the tuft with its needles and removes the fibres which are not held by the nippers along with the neps and foreign matter. The feeder cylinder, the linear comb and the drawing off cylinders remain still.

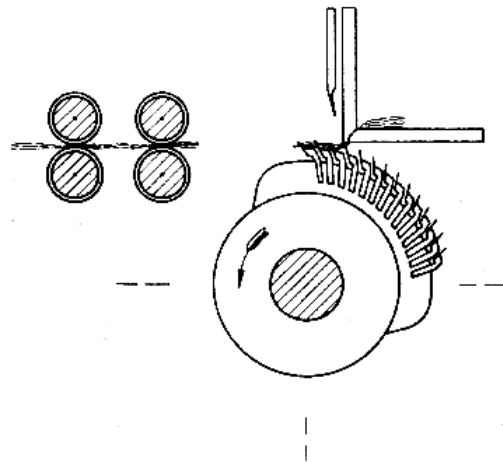

*Fig. 37 Combing action*

2<sup>nd</sup> stage: the previous tufts move backwards.

As the last needles on the circular comb leave the tuft, the drawing off cylinders rotate in a negative direction taking a section of the fibrous web back by around 5 cm. The nipper advances towards the drawing off cylinders and opens. The feeder cylinder, the circular and linear combs and the stripper cylinders remain idle.

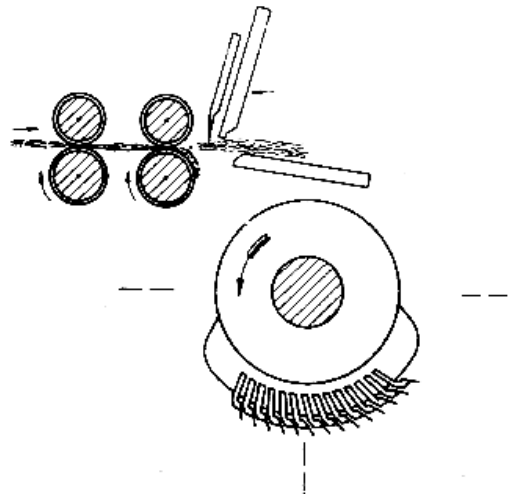

*Fig. 38 Moving backwards*

3<sup>rd</sup> stage: condensation of the tufts

The drawing off cylinders rotate in a positive direction, bringing forward the fibres towards the exit of around 8-9 cm. The linear comb sinks its needles into the tuft, preventing the uncombed fibres from advancing. The nipper, completely open, reaches the minimal distance from the drawing off cylinders and then reverses its direction. While the nipper moves backwards, the feeder cylinder rotates, taking the small lap forward by around 4-6 mm. The circular comb is not in action.

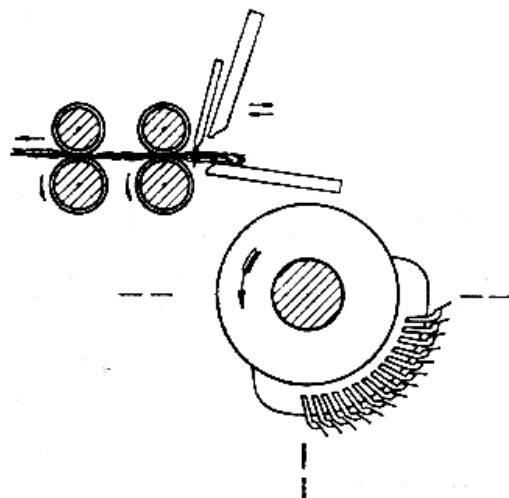
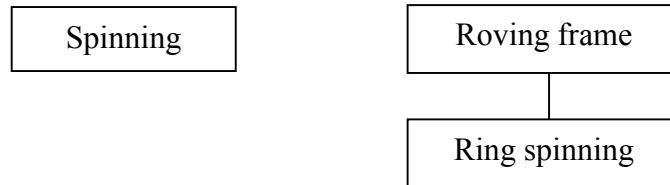

*Fig. 39 Condensation*

# Spinning

Following the drawframe stage, the slivers undergo the final passages towards being transformed into yarn, which are the following:

## Cycle of carded cotton



## Cycle of combed cotton

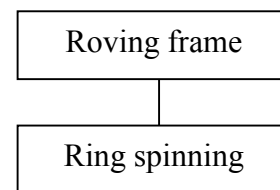

In both types of spinning, the yarn undergoes the following packaging and finishing operations, not necessarily carried out in the order given.

Winding

Waxing

Singeing

Doubling and  
twisting

Reeling and  
winding off

These steps do not necessarily apply to all yarns, therefore the order is only indicative. As the individual machines are described, the function and eventual combination of various operations will be stated.



## Roving frame

The task of this machine is to transform the sliver coming from the drawframe into roving. It is present in the carded ring spinning cycle and in the combed ring spinning cycle, in the first case it is found following the post-carding drawframe (one or two drawing steps), while in the second case after the post-combing drawframe.

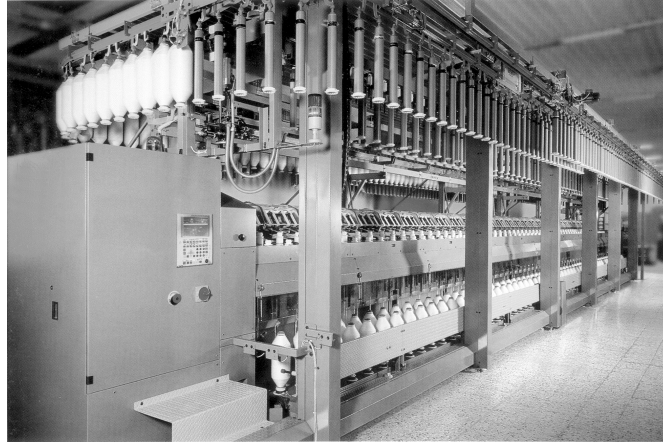

*Fig. 40 Roving frame with automatic doffer*

Transforming the sliver into roving occurs in a continuous manner through three stages:

- drawing
- twisting
- winding

Drawing is generally carried out by a draft system with 3-cylinder weighing arm with double apron capable of working with entering sliver counts of 4900 tex to 2460 tex (0.12 Ne to 0.24 Ne) and counts of the delivered roving of 2200 tex to 200 tex (0.27 Ne to 3 Ne).

The draw value that can be achieved has a range of between 4 and 20 and can work fibres of a length up to 60 mm.

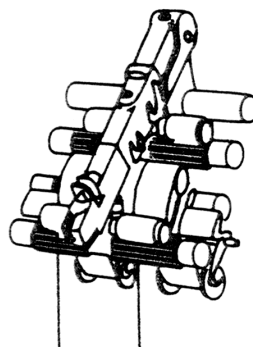

*Fig. 41 The drafting system*

It can be seen in the figure that the drafting system has a normally low preliminary draft of between 1.2 and 2, while the more consistent draft comes from the main draft area given by the action of the aprons, permitting better control over the movement of the fibres.

Overall drawing can also reach values of 20, but generally the process is carried out with lower values for better final results.

The twist is given by the rotation of the flyer located on the spindles, in fact the exit roving coming from the draft cylinders enters in the higher hole of the flyer, passing through the hollow arm and then winding on the bobbin.

The twist value is given by the following equation:

$$\text{No. twists} = \frac{\text{Revolutions of the spindle (flyer)}}{\text{Exit length 1st cylinder}}$$

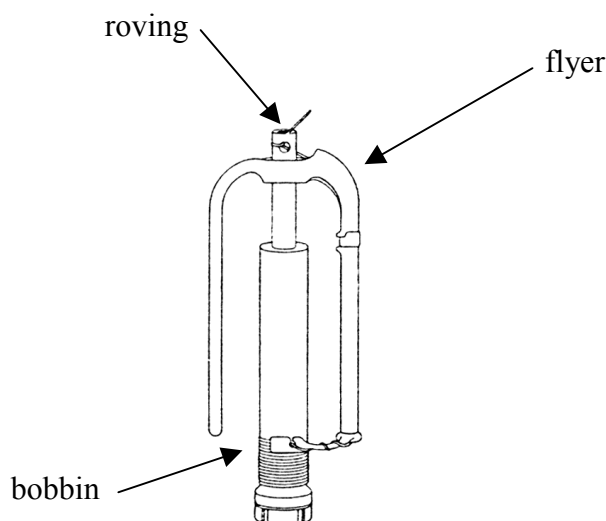

*Fig. 42 Flyer and bobbin*

The number of revolutions of the spindle can reach up to a maximum value of 1500 rpm. The twist rate given by the roving has a value of between 10 – 100 T/m (0.25 T/inch).

It should be noted that the twist value to give the roving, this being an intermediate product, has a fundamental practical importance for the next processing stage.

The minimal value limit must guarantee even working of the roving during feeding to the spinning frame, while the maximum value must not impede the draft action of the fibre gliding to the spinning frame.

The thread is wound by the action of the bobbin rotating at a higher speed than the flyer (spindle), in order that on every turn the bobbin makes in addition to the spindle, a coil of roving is wound on the bobbin. The length of coil is shorter for the first layers and longer for the last.

To keep the length of the wound roving and the number of spindle revolutions constant in the unit of time, it is necessary for the bobbin to gradually reduce its rotation speed as layers are formed over layers, and this must be inversely proportional to the winding diameter for all the successive layers of roving added to the bobbin.

The distribution of the roving along the bobbin is given, on the other hand, by the upward and downward movement of the carriage; because of the frustrum shape of the bobbin on each layer wound the distribution height is reduced, but the winding diameter increases with a consequential increase in the coil length of the roving wound and the time taken to wind the coil.

Even the translation speed of the carriage must be reduced in order to maintain the same pitch of the winding helix for all layers.

In conclusion, bearing in mind the fact that the feed to the roving from the draft cylinders is always constant, at each layer there is a progressive reduction in the number of revolutions the bobbin makes and the translation speed of the carriage is diminished, which reduces its travel at every layer.

These variations occurred in conventional machines through speed variators (eg pairs of cones) for the carriage translation speed and the variator plus a differential for the bobbin rotation speed.

In modern roving frames, the commands for the various functions carried out are given by various motors (see Figure 43) independently coordinated by a central machine control system, permitting better functioning and a reduction of energy consumption and noise level.

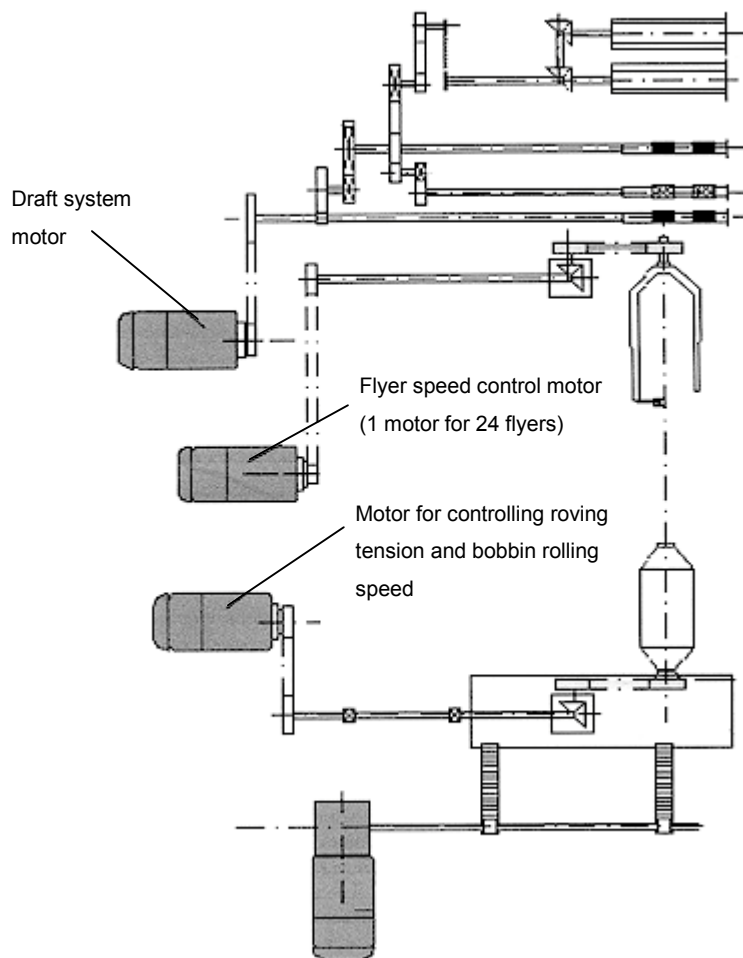

*Fig. 43 Roving frame motors*

Furthermore, the central machine control system is capable of maintaining control over all technical parameters, all data is stored and can be recalled immediately upon demand.

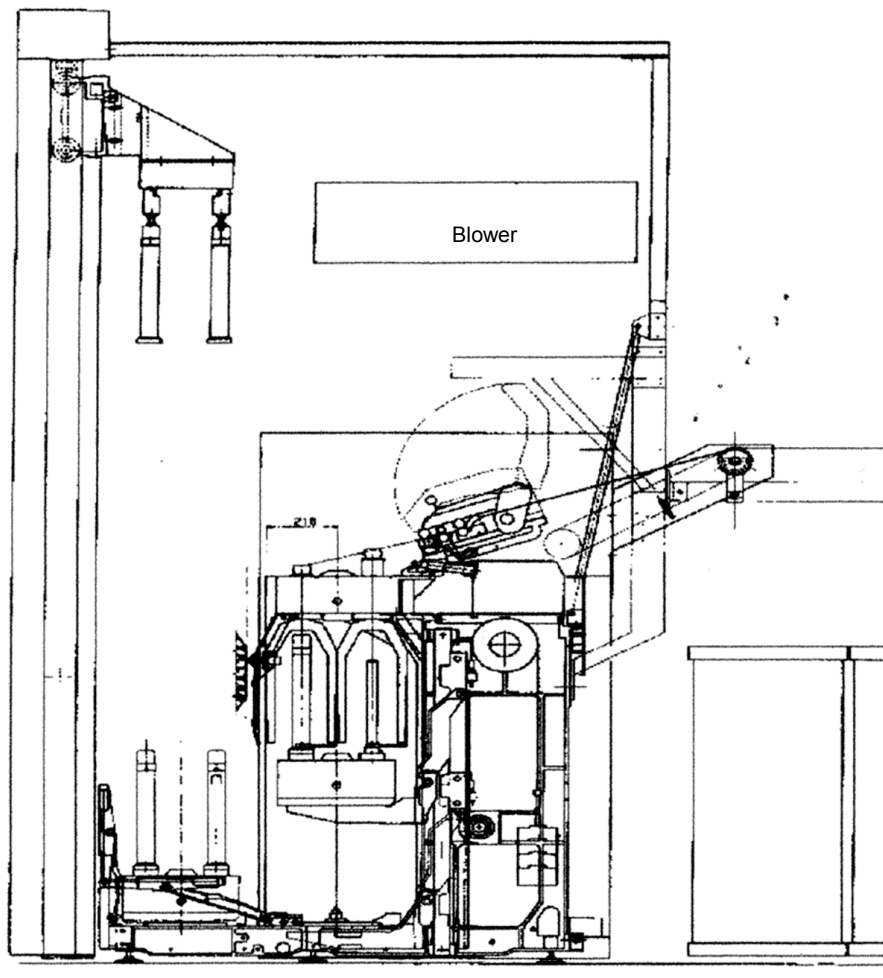

*Fig. 44 Functional diagram of a roving frame*

A modern roving frame can normally carry up to 120 spindles.

The roving frame can be unloaded of bobbins manually or an integrated automatic removal system can be used which provides an automatic suspended link between the roving and spinning frames.

Electronic apparatus is used for quality control of the roving from the frame by controlling the count, twist and evenness of the section.

### **Calculating output**

An example of calculating machine output:

Count delivered Ne 1, twist 47.24 T/m, spindle speed 1200 rpm, No. of spindles 96.

Theoretical linear production =  $1200/47.24 \times 96 \times 60 = 146,316.68$  m/h.

Pondered theoretical production =  $146,316.68 \times 0.59/1 = 86,326.84$  g/h

Real production with performance equal to 92%:  $86,326.84 \times 0.92 = 79,420.69$  g/h.

## Ultimate spinning

This term describes final operation needed to obtain yarn.

In cotton spinning, the following machines are used:

- cycle of carded cotton: ring spinning frame, open-end spinning frame
- cycle of combed cotton: ring spinning frame

## Ring spinning frame

The ring spinning frame, commonly called the ring, is the conventional spinning system and it transforms the roving from the roving frame into spun yarn using the operations of:

- Drawing
- Twisting
- Winding

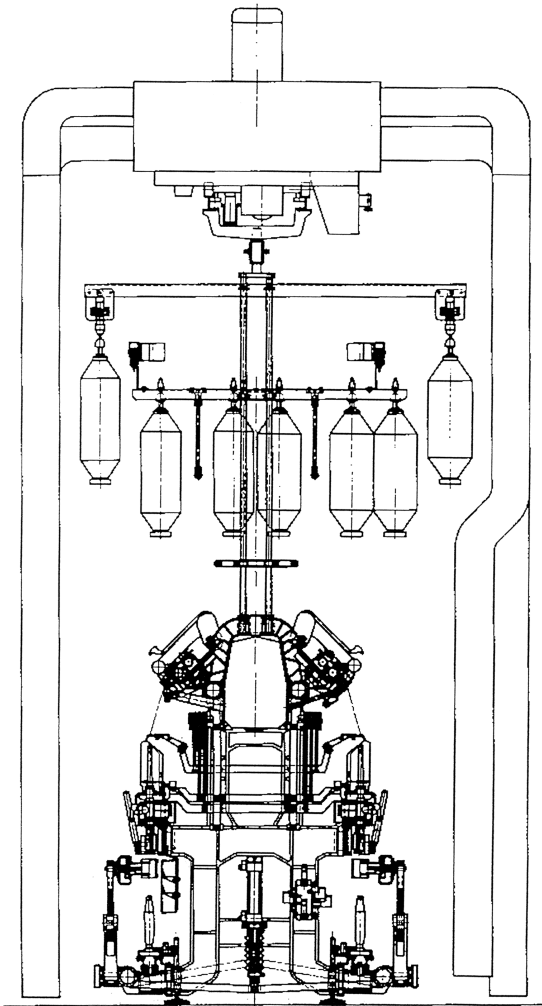

*Fig. 45 Ring spinning frame*

The following figure shows a functional diagram of a ring spinning frame.

As can be seen in Figure 45, the fixing area for the roving bobbin of the machine is in the upper part, the draft is imparted in the central area and the lower part is home to the bobbin rail.

A modern spinning frame can hold a high number of spindles, which generally vary in blocks of 24 spindles from 384 to a maximum of 1080 with a gauge of 70 mm and 1008 for a gauge of 75 mm.

The draw is made with a “3 on 3” system with double-apron drafting system with pressure generated by a weighing arm system. The drafting unit is in an inclined position compared to the ground in order for the twisting to be started the moment the fibre leaves the first draft cylinder where twisting is avoided to prevent the yarn from breaking.

The drafting unit system is capable of working fibres of up to 60 mm (carded and combed cotton, blends and chemical fibres) with draw values of between 10 and 80.

The roving is first subject to a preliminary draft with values of between 1.5 and 2 and successively a main draft in the apron area until the desired count is achieved.

The spinning counts are between Ne 5 and Ne 150 (118 – 4 Tex).

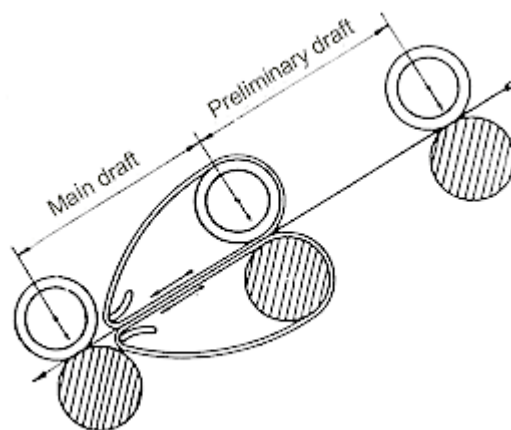

*Fig. 46 Scheme of the drafting unit*

On conventional spinning frames, when the fibre comes out of the draft cylinders, the so-called “spinning triangle” is formed, which is a cause of breakage, unevenness and yarn hairiness. To eliminate the spinning triangle, the fibres must be condensed before they leave the draft cylinders.

Now, compact spinning systems have been developed, also called condensation systems, which are able to compact the fibre before twisting eliminating the spinning triangle and integrating all the fibres including short ones. Compacting has a notable influence on the structure of the yarn and it consequentially improves physical and mechanical properties leading to better evenness and strength of the yarn. These factors have provided a fundamental contribution to progress in the spinning and weaving process.

The compact spinning system, represented in Figure 47, is made up of a pair of 4-4’ entry cylinders, a pair of 3-3’ cylinders with apron, the pair of 2-2’ delivery cylinders from the aspiration tube A with latex apron G and 1 delivery cylinder. The first two draft ranges are in common with those of normal spinning with the same problems faced during operation (waste, pressure and so on). The S tube, subject to depression, presents a opening between A and B, the fibre bundle previously drawn is then subject to depression and condensed between point A and point B of final gripping. The pressure cylinder 1 is moved by a toothed wheel on the pressure cylinder 2’.

In the section A – B, condensation occurs, helped also by the opening in the aspiration tube which is at an angle compared to the direction the fibre is moving in order to give the bundle of fibres the desired twisting on their axis, an important factor in working short fibres. Condensation occurs until the final exit point and this reduces the spinning triangle to a minimum.

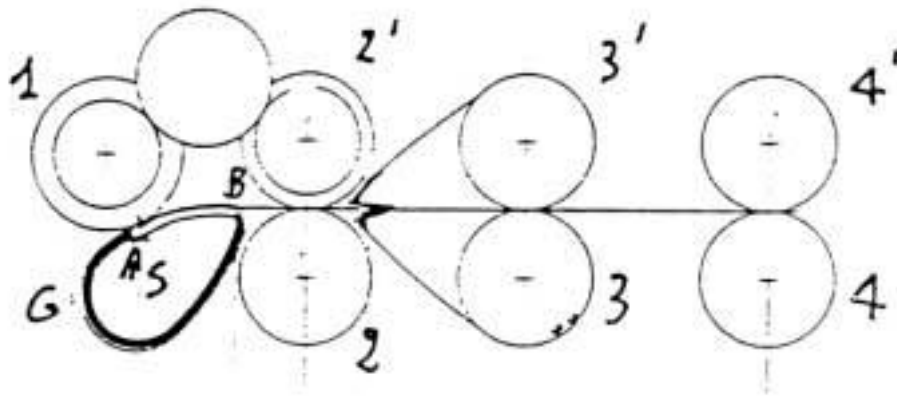

*Fig. 47 Model of compact spinning*

Fibre can be condensed by systems different from the one illustrated. However, all systems require the presence, at the exit from the main draw field, of a cylinder with aspiration capabilities for condensing the fibres eliminating the formation of the spinning triangle.

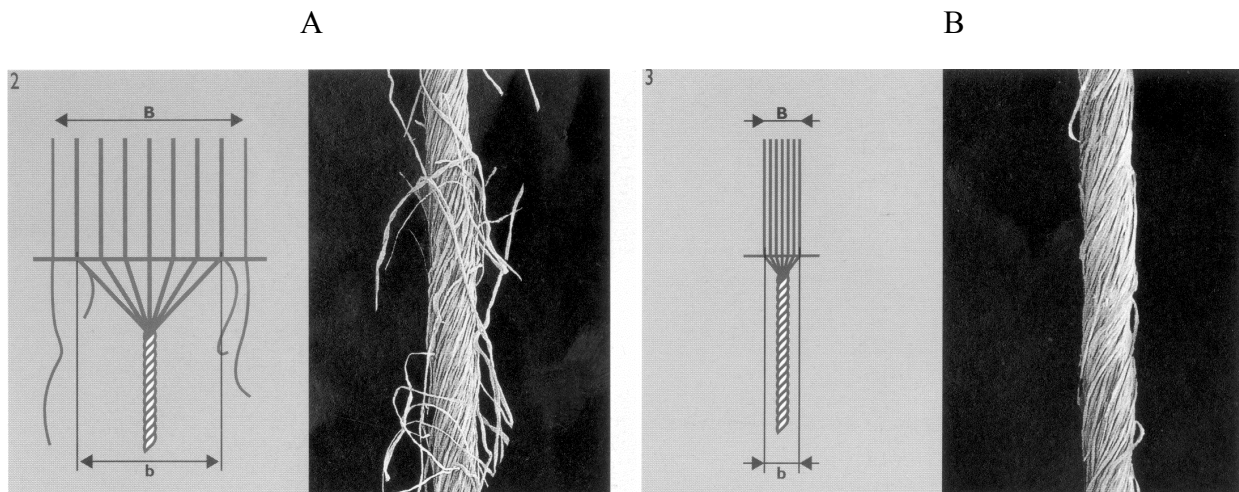

*Fig. 48 Comparison between a normal ring-spun yarn (A) and a yarn produced (B) with the condensation technique*

A modern ring spinning frame adopts two separate commands using brushless motors for the draft cylinders. With this system, the draw parameters necessary for changing the count are set on the command panel without requiring any equipment to be changed.

The yarn, on delivery from the draft cylinders, passes through a yarn guide and then through a traveller, and then it is wound on the tube fitted on the spindle.

The effective twist is that given by the number of rotations made by the traveller, whose rotation is caused by a dragging action and which is subject to variations in speed depending on the winding diameter, varying during the formation of each individual layer of yarn on the bobbin due to the effect of the vertical movement of the rail. These differences in twist are in part compensated for in the axial rewinding of the yarn, because as the diameter of the bobbin varies coils are added or removed with a criteria opposed to what previously happened in function of the different speed of the traveller.

In practice, the twist is conventionally taken from this formula:

$$\text{No. twists} = \frac{\text{Number of spindle revolutions}}{\text{Exit length 1st cylinder}}$$

The direction of twist S (left) or Z (right) depends on the direction of spindle rotation.

The number of twists is measured in twists per metre (T/m); for cotton yarns, the T/inch is also used as a measurement.

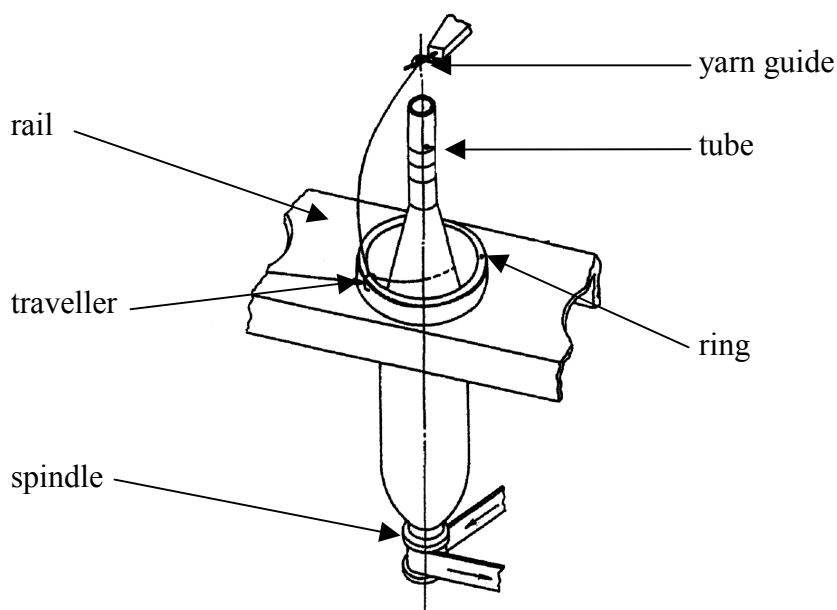

*Fig. 49 Ring and traveller system*

The spindle speed on a modern spinning frame reaches 25,000 rpm, with the possibility of giving the yarn a twist of between 4 and 80 revolutions/inch (158 – 3150 revolutions/m). The movement of spindles on the spinning frame is driven by a tangential double belt drive system, saving much energy.



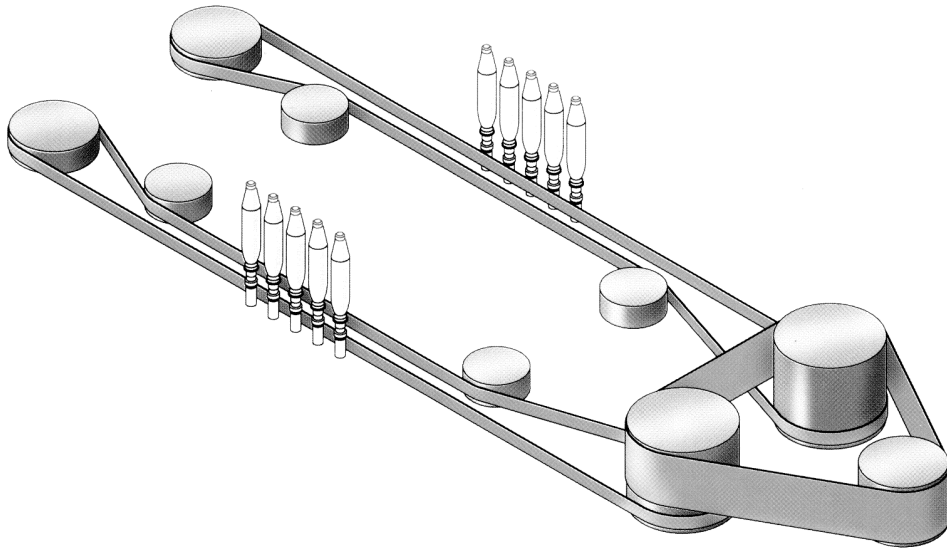

*Fig. 50 Tangential spindle drive system*

The twist number (T/m) and direction (S or Z) to attribute to yarns depends on the type of fibre and features required by the yarn according to its application.

The calculation of the number of twists is given by the following formulae:

$$T/m = k_m \cdot \sqrt{Nm} \quad \text{where: } \begin{array}{l} k_m \text{ coefficient of twists in rpm.} \\ Nm \text{ Metric yarn count} \end{array}$$

$$T/\text{inch} = k_e \cdot \sqrt{Ne} \quad \text{where: } \begin{array}{l} k_e \text{ coefficient of twists in twists/inch} \\ Ne \text{ English yarn count} \end{array}$$

$$T/m = \frac{K_{\text{tex}}}{\sqrt{\text{Tex}}} \quad \text{where: } \begin{array}{l} K_{\text{tex}}: \text{Tex coefficient of twist in T/m} \\ \text{Tex}: \text{Tex count of yarn} \end{array}$$

The twist coefficients are determined practically in relation to the characteristics of the cotton being used and the type of yarn, depending on the use for which it is destined.

The traveller, traditionally in steel, is the most delicate part of the machine, as it is not able to support high speeds. When the spindle travels at high speeds, friction is created that could cause the traveller to heat up and get damaged.

Therefore, as the traveller speed determines the revolutions of the spindle and the diameter of the ring, for fast spindle speeds the diameter of the ring must be contained and as a consequence, so must the bobbin.

For example, a spinning frame can have ring diameters that vary between 36 and 54 mm with spindle gauge of 70 – 75 mm and a tube height of between 180 and 260 mm.

There are three fundamental shapes of the travellers, called C or M or elliptical

The figure below represents the three types.

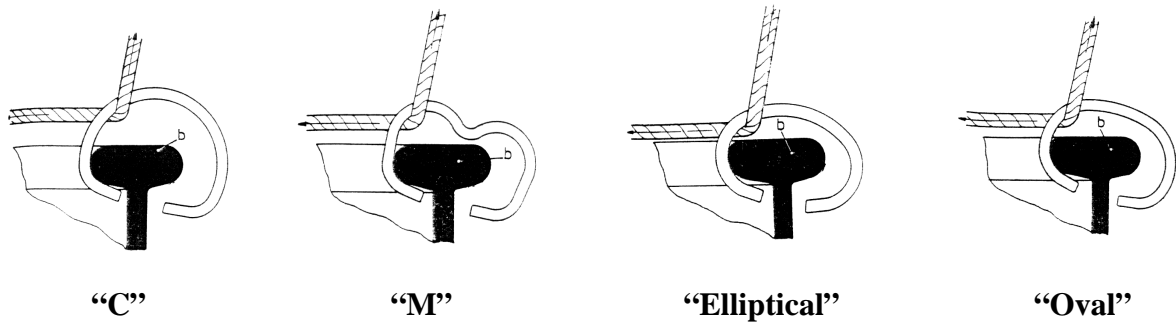

*Fig. 51 Travellers*

The “C” type ring guarantees space for the passage to thread, but it presents a high barycentre (b), the “M” type has a low barycentre to guarantee the passage of the yarn, the elliptical type ring has a low barycentre, but offers less space for the passage of the thread.

The latter is preferred because it has the lowest centre of gravity in the point of contact with the ring, establishing a position of equilibrium so that the contact with the ring is determined in a single point of the internal flange, making friction minimal to guarantee passage of the yarn. Combining the type “C” with the elliptical one, a type of traveller known as “oval” is formed which maintains the advantages of the elliptical traveller but provides a larger space for the yarn to pass. The section of yarn that goes from the traveller to the fixed thread guide in its rapid motor driven motion around the ring is subject to a combined action of centrifugal force and air resistance, so it swells forming a particular curve called “balloon”. An excessive balloon effect leads to a maximum size, larger than which the balloon becomes plaited causing the thread to break.

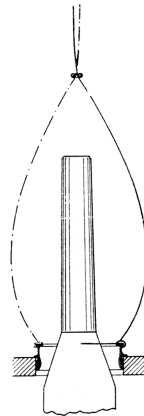

*Fig. 52 “Balloon” effect*

It is important therefore to limit the diameter of the balloon by reducing the distance between the thread guide and the traveller using special limiter rings.

Another efficient system, used for coarse yarns, uses cutting edge spindles to collapse the balloon effect.

Winding occurs with the winding of the yarn on the tube forming the bobbin, the dimensions of this vary from machine to machine depending on the diameter of the ring and the height of the tube. The distribution of yarn on the bobbin is given by the up and down movement of the ring rail. The rise time is about three times longer than the descent time, in order to provide better compactness for the bobbin when the coils of wound yarn cross.

In addition, the rail travel (an equal width on each layer) is progressively moved upwards by a particular device, the extent of the movement must depend on the yarn count. For coarse yarn the upward movement of the rail must be more rapid as it winds a shorter length of yarn on a par with the weight of the bobbin, and the opposite happens for a finer yarn.

The length of yarn wound on each rise and descent travel of the rail is called run-out.

The weight of the bobbin can vary from around 50 to 100 grams.

In order to maintain a clean yarn, the spinning frames used nowadays are equipped with systems capable of removing dust and fibre residue that can form during processing. If the yarn should break, a particular aspirator tube collects the fibre as it leaves the draft range. There are special cleaning systems for the draft cylinders, while a travelling cleaning system made up of flexible tubes mounted on suspended tracks takes care of general machine cleaning.

One manufacturer has designed and made a system called Wondercleaner made up of a travelling cleaner and reserve yarn cleaner. The cleaner at the base of the spindles is hooked to a travelling blower between the two doffers only when it is needed to be used. This cleaner cuts the coils of yarn wound around the base of the spindle and the blower sucks them up rather than leaving them fall to the ground. With this system, efficient for every count, the actual cutting yarn blades are removed and a cleaner room results.

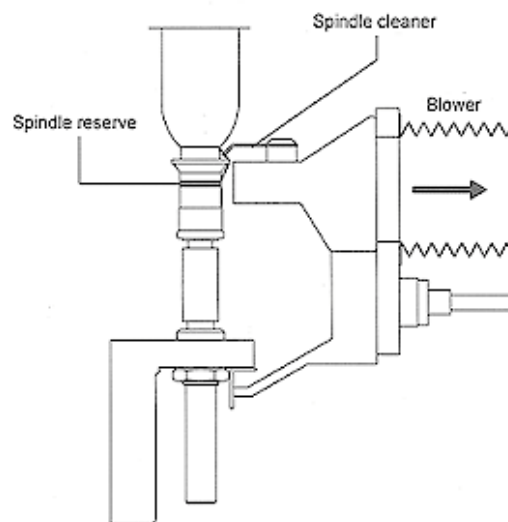

*Fig. 53 Detail of the Wondercleaner system*

The spinning frame is equipped with a control panel where the parameters needed for the spindle speed, main draft, yarn twist and formation of bobbins can be set without requiring any change to equipment. Special software also permits the production of iridescent yarns.

In order to reduce operator intervention, modern spinning frames are equipped with devices that carry out doffing of full bobbins completely automatically as well as inserting empty tubes.

The time needed for doffing is around 2 – 2.5 minutes.

There are also systems to provide a direct connection between the spinning frame and winding machine.

To state the quality of the yarn, the checks normally carried out are as follows:

- evenness of count
- evenness of twisting
- evenness of the section
- hairiness
- tensile strength

## Open-end spinning

This is normally used in cotton carded spinning. The frame is fed with slivers from the drawframes which transform the yarn directly into packages, eliminating the passage on the roving frame and, in many cases, further packaging operations.

The figure below represents an example of rotor (or open-end) spinning frame.

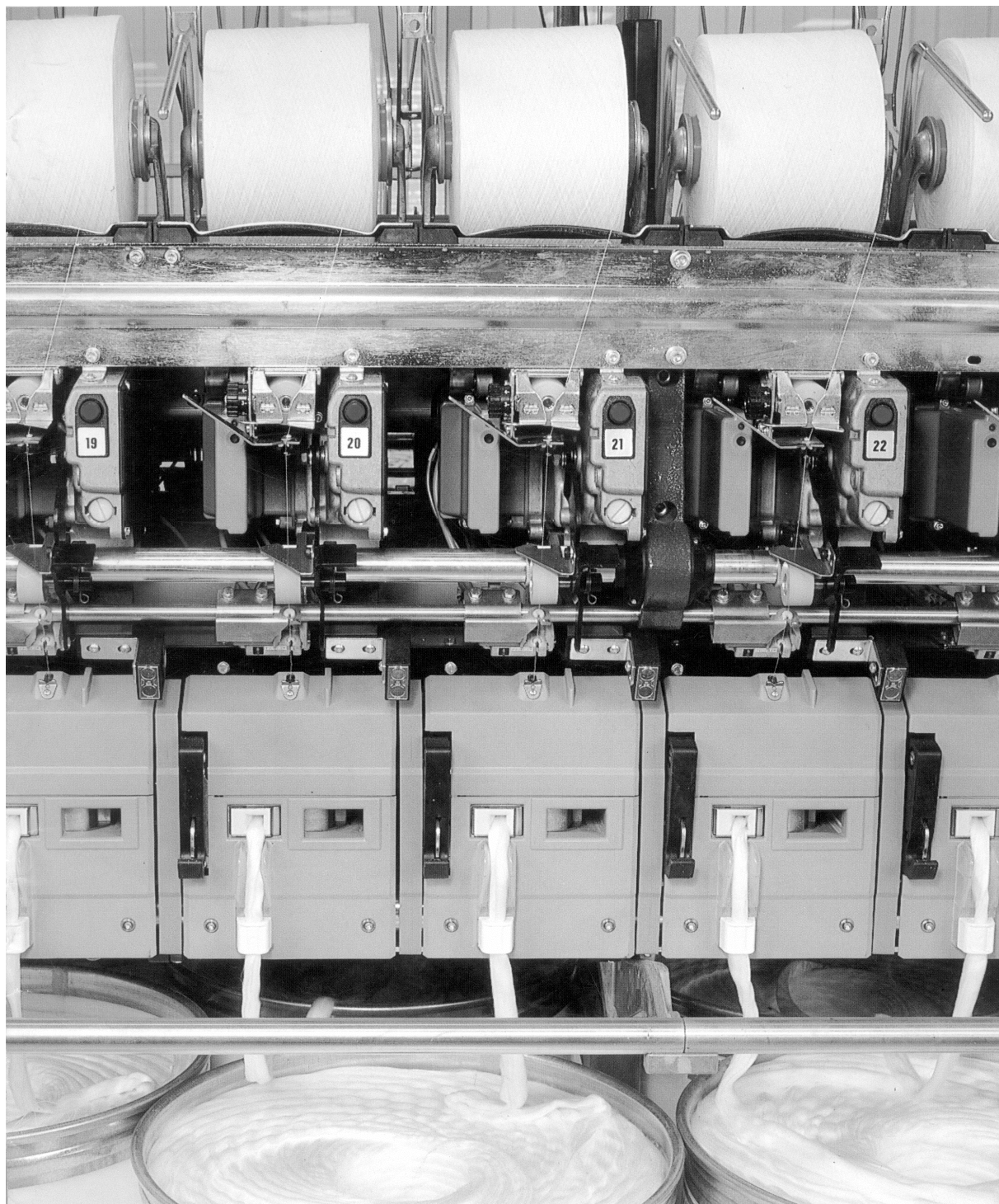

*Fig. 54 Rotor spinning frame*

The main function of the spinning unit is as follows. The sliver from the drawframe is introduced by a feeder cylinder and is subject to the action of an opener with saw-toothed wiring which rotates at a speed of between 6000 and 9000 rpm, separating the sliver into single fibres, then the fibres are sent to the rotor through a vacuum channel. The rotor, whose diameter is between 32.5 and 54 mm, rotates at a very high speed over 100,000 rpm, and compacts the fibres partly thanks to its special shape, twisting the fibres at the same time.

The processing data of an open-end frame for cotton are normally as follows:

- sliver count Ne 0,10 – Ne 0,27 ( Tex 5900 – Tex 2180)
- yarn count Ne 5 – Ne 40 (Tex 120 – Tex 15)
- draft range 16 – 250
- twists 300 – 1500 T/m.

The yarn formed in this way then passes to the winding unit which makes the packages, that are either cylindrical or conical. The cylindrical packages can have a diameter of 300 x 152 mm and the conical ones a diameter of 270 x 152 mm.

The winding speed can reach up to 200 m/min.

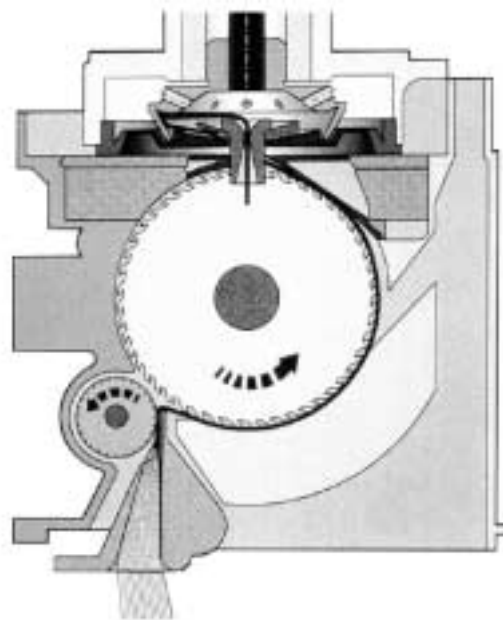

*Fig. 55 Diagram of rotor spinning frame*

The yarn produced by the rotor spinning frame presents different features from the conventional ring yarns, as the fibres tend to be arranged around the edges of the rotor in a casual manner, rather than as a result of the length of the fibres themselves or with a preferential migration of fibres.

It follows that a regular yarn is formed but with the presence of longer fibres in the yarn that also hold other fibres, giving the yarn a characteristic look and a higher degree of hairiness.

Modern rotor spinning frames, due to some technical improvements such as more efficient cleaning, thanks to pneumatic evacuation of impurities in the channel, the self-aspirating rotor system, the particular design of the rotor transport channel, the adoption of separators with particular profiles that determine a better distribution of fibres in the groove of the rotor, are able to produce yarns of a better quality and more similar to those made on ring spinning frames.

The following figures show a macroscopic view of the structure of the two types of yarn, the first produced on a modern rotor spinning frame (100% cotton Ne 30), the second on a conventional machine (100% cotton Ne 30).

It can be seen that the first yarn presents better evenness and less hairiness. As a consequence, the improved parallelisation of the fibres and more regular final structure will give the yarn better elongation resistance, and therefore generally offer more sophisticated performances.

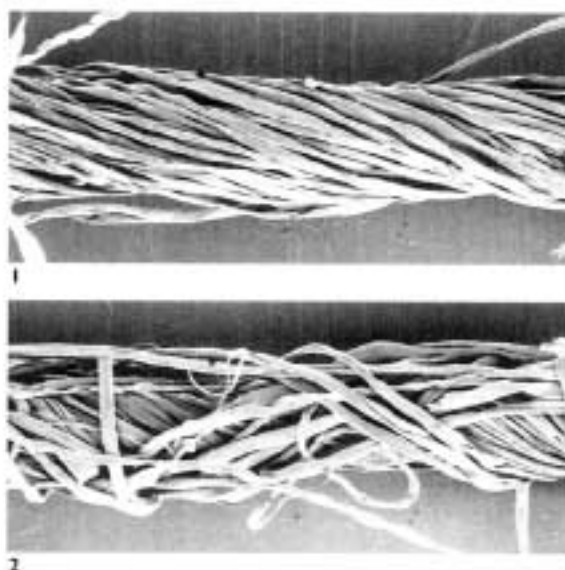

*Fig. 56 Open-end yarn structures*

Furthermore, the waxing system is able to guarantee distribution of the wax over the yarn in a regular manner according to the quantity desired.

The machine is automated by carriages for automatic piecing of the thread and package doffing of a number variable between 1-2-4 per machine.

A machine normally has two completely independent sides, with automatic distribution of empty tube yarn piecing carriage, package doffer and rotor cleaning. The machine is generally mounted with modules of 24 units on 2 sides and carries a maximum number of 288 units per machine.

The machine also has a system for quality control, productivity and maintenance. The computerised system automatically controls production, it manages the spinning units and shows output data for each individual unit. Furthermore, the system is capable of self-diagnosis when machine alarms occur and in the eventuality of inefficient individual units.

It is also possible to apply electronic yarn clearing systems to eliminate yarn defects directly on the spinning frame.

## Winding

Winding is the creation of large yarn packages that can be easily unwound. This makes using the yarn on subsequent machines both easier and more economical.

In order to form packages of the right weight for subsequent processing stages, the winding machine can be fed by ring-spun yarn bobbins, by packages originating from open-end spinning machines, or by cylindrical/conical packages derived from previous processing stages.

Packages can thus be subdivided according to their shape:

- a – cylindrical
- b – conical, with tapers ranging from  $5^{\circ}$  to  $15^{\circ}$
- c – cones with tapers of up to  $4^{\circ}$

The yarn unwound from the package passes through yarn tensioning and control systems, and with the help of a grooved cylinder, is wound evenly around the package; the yarn enters the recess in the cylinder, thus the rotary movement of the cylinder corresponds to the translation of the yarn.

Winding machines currently have independent heads with individually adjustable motors.

A modern winding machine can process yarns ranging from a count of Ne 2 to finer ones, at a winding speed of 400 to 2000 m/min.

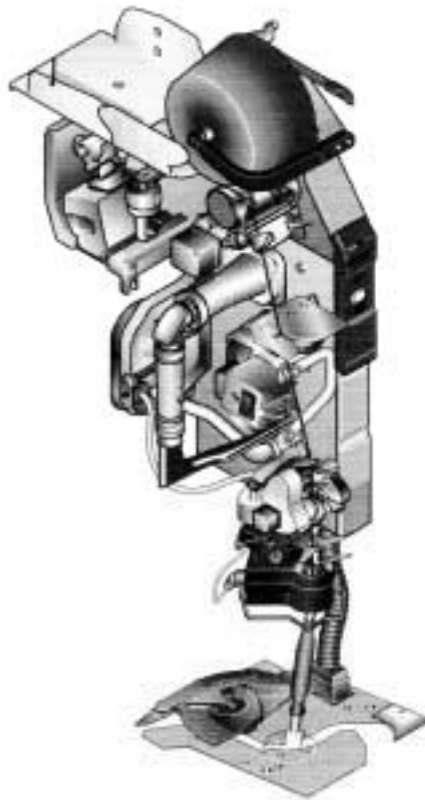

*Fig. 57 Winding head*

Winding is more than just transferring yarn from one package to another. Further functions of winding are to check the yarn and to eliminate any faults found. This is done by a process called “clearing”, i.e., by passing the yarn through an electronic device, known as a yarn clearer, which assesses it according to set parameters (fault section and length). If these set values are exceeded the yarn is cut and spliced – a splice being deemed preferable to a fault. Splicing is done using the air-splicing system or the Twinsplicer system, which, reconstructing the yarn mechanically, also checks the untwisting, tail draft, tail condensation and twisting, thereby improving the result of the operation. A join created in this way is less visible, consistent, stronger and repeatable. There exists an innovative combined water- and air-driven splicing system that is particularly suited to compact cotton yarns.

The machine is equipped with a special device to avoid the winding defect known as ribboning. This problem is caused by irregular package formation following the deposition of too many coils in certain points. Basically, the package-holding arm is made to effect an oscillating movement both in the vertical (A) and in the horizontal (B) planes (see Figure 58). These two movements can be combined in various ways so as to respond to all processing requirements.

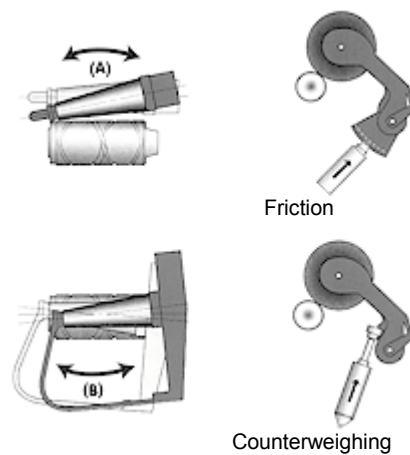

*Fig. 58 Anti-ribboning device*

The tension of the yarn is constantly monitored by an electronic sensor located prior to the cylinder. Thanks to the headstock computer, this sensor interacts with the yarn-tensioning device to modify, as necessary, the tension exerted on the yarn. This keeps the package density constant.

A modern winding machine carries out the following operations automatically;

- package doffing
- bobbin loading
- cone feeding
- linkage to spinning frames with bobbin picking up

For the last of these, the machine can be equipped with a system that allows it to detect two different lots of bobbins and to keep them separate by the application of lot identification tags, which are inserted into the flange and detected upon winding head entry.



## Retraction winding machine for bulky yarn production

This machine is equipped to carry out, in continuous mode, the shrinking of acrylic yarns and HB, also containing elastane, and the production of bulky yarns (blended and pre-dyed).

It has a maximum winding speed of 1000 m. per minute and a shrinking field of 0-30 %.

The operating principle, illustrated in Figure 59, is the following: the yarn is pneumatically inserted and, by means of a rotating distributor nozzle, wound in parallel coils around 4 aprons, which effect a slow translation movement. The yarn winding areas and part of the aprons are suspended in a forced air circulation chamber heated by electric resistances. This chamber (oven), whose temperature can reach 165° C, is where yarn retraction occurs; the yarn, supported only by the two upper aprons is perfectly free and able to shrink in ideal conditions. Exiting the shrinking chamber, the shrunken yarn passes through a cooling zone, after which it is unwound and then wound on to a new package. A overfeeder roller reduces the tension of the yarn as it leaves the oven.

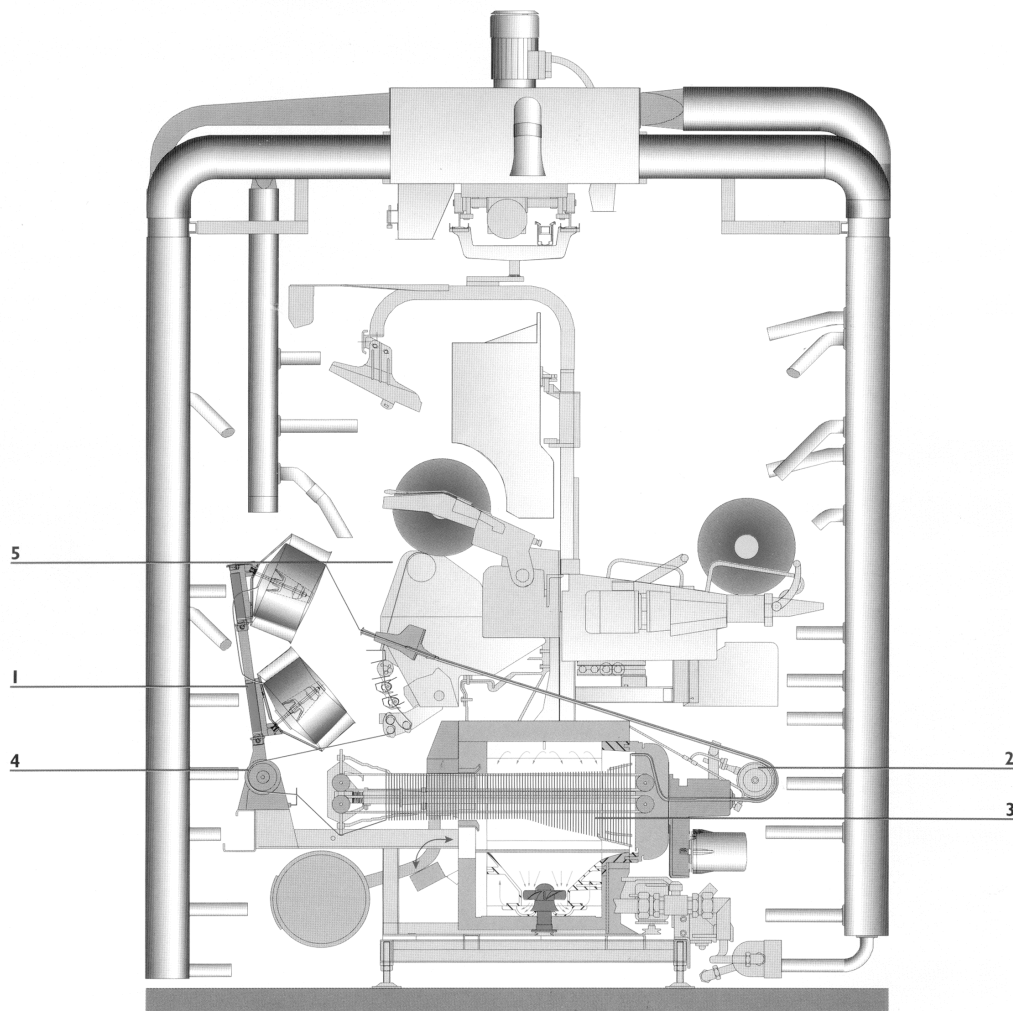

*Fig. 59 Shrinking stage: 1- feeding creel; 2 – entry overfeeder pulley; 3 – yarn distributing unit; 4 – takeup overfeeding roller; 5 – winding head*

## Waxing

Waxing serves to lubricate the yarn, reducing to a minimum its coefficient of friction with the parts with which it comes into contact.

This operation is normally carried out on yarns destined to be processed on knitwear machines, on which smooth running of yarns is essential.

Waxing is carried out on the winding machine, which is equipped with a positive-drive adjustable waxing system that guarantees constant waxing of the yarn; there is also control device that stops the machine should the wax run out.

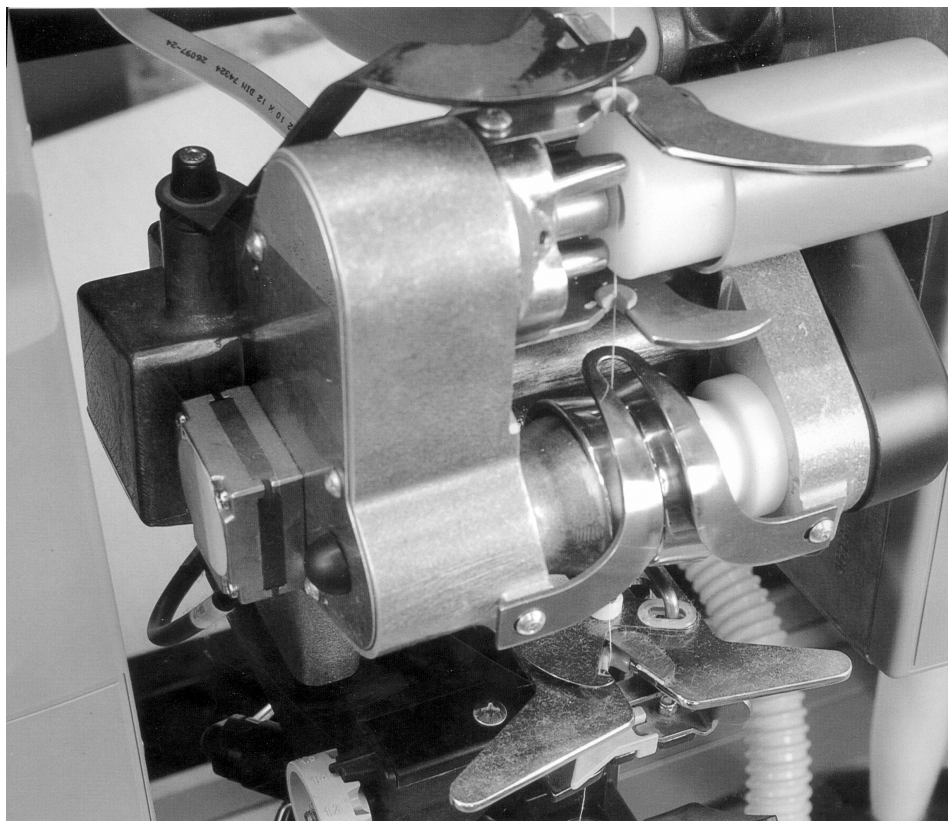

*Fig. 60 Waxing device*

## Singeing

Singeing is an operation carried out in order to eliminate yarn hairiness. The singeing system consists of a package-to-package winder and a gas burner.

The yarn is passed through the flame, which singes the protruding fibres that cause the hairiness. It runs at a rate of 400 to 1000 m/min.

The machine must, in order to obtain even singeing, maintain a constant yarn speed and an even flame.

The singeing system, in addition to normal machine control devices, also has a fly fibre evacuation system and a flame temperature control system.

Since this operation reduces the weight of the yarn, even by as much as 5-6 %, the yarn count will also be modified, and this must be borne in mind when designing the yarn.

## Doubling

The purpose of this operation is to unite two or more ends on a package prior to twisting. The doubling machine, like the winding machine, is fed by packages of yarn, generally pre-cleared, which are positioned in its lower section. Unlike the winding machine, the doubling machine must have yarn tensioning devices that can guarantee even tension of all the yarn ends, as this is essential for successful twisting.

The packages produced can be cylindrical or conical, and the winding speed can exceed 1000 m/min.



*Fig. 61 Doubling machine*

## Twisting

The purpose of this operation is to unite, by twisting, two or more doubled yarn ends, in order to obtain a stronger yarn. It is a two-stage process: first doubling and then twisting. Some modern machines carry out these two operations contemporaneously.

In the past, twisting was carried out using ring twisting machines, which are similar to ring spinning frames, except that they are fed by packages of doubled yarn and via a feeding cylinder that consists of a metal shaft with pressure cylinders to keep winding speeds constant.

Nowadays, two-for-one twisters are used, thus called because the yarn undergoes two twists for each turn of the spindle.

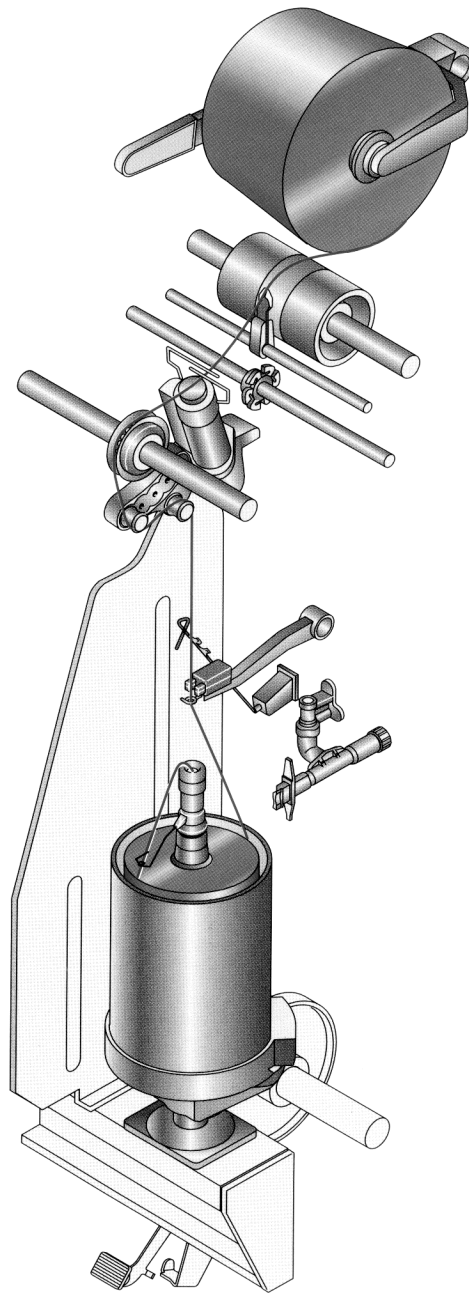

*Fig. 62 Two-for-one twister*

The operating principle is illustrated in Figure 63, which shows how the yarn undergoes a first twist between its entry into and exit from the spindle (A-B) and a second twist between point B and the thread guide C. This is possible because the doubled yarn package does not move; instead, it is the yarn that revolves around the package.

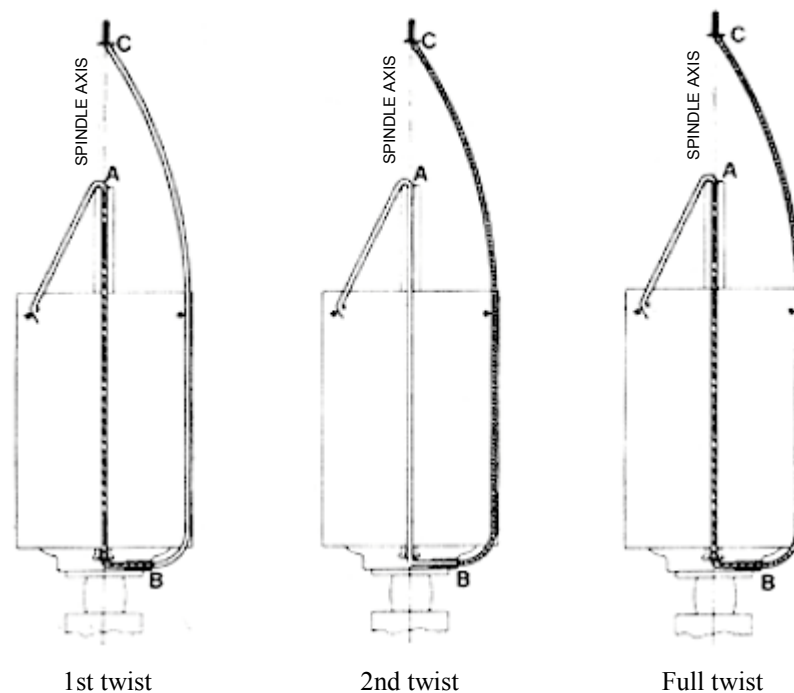

*Fig. 63 The principle of two-for-one twisting*

The twisted yarn is then wound, forming one package per spindle located in the upper part of the machine.

The advantages offered by this machine, in comparison with the old ring spinning machines, are the following: two twists are effected for each turn of the spindle and this means higher output rates, direct winding of large packages, fewer knots, and the possibility of carrying out 2-ply assembly directly on the machine.

The machine produces, directly, packages with the following tapers  $0^{\circ}$ -  $3^{\circ}30'$ -  $4^{\circ}20'$  -  $5^{\circ}57'$ . It is possible to have different spindle gauges: 200-240-300 mm, and the number of spindles, which depends on the gauges, can range from 16 to 360.

The machine is equipped with gear boxes, to vary the number of twists, the twisting direction (S/Z) and the yarn crossing angle.

The two-for-one twisting machine currently offers high operational flexibility, working both with controlled and free balloons, extracting the balloon limiter.

This makes it possible to process delicate fibres that could otherwise be damaged by excess friction. Following the carrying out of doubling on special machines, and providing certain measures are taken, it is also possible to process woollen, cotton, viscose and silk yarns that incorporate the elastane thread that is increasingly used in the manufacturing of textile goods.

An optional electronic system can be employed to monitor correct functioning of the machine.

This system detects missing yarns, the presence of extra yarns, and, in accordance with planned tolerances, the formation of tangles. Modern two-for-one twisting machines incorporate pneumatic threading systems and an automatic tying carriage, a package lifting system, and slowing of the machine in the event of yarn breaks or the package running out (following breaks, this slowing action is delayed to allow the twisted yarn to finish winding and thus to avoid damaging the surface of the package), a travelling blow/suction cleaner.

If required, waxing can also be carried out, and in some machines, in order to reduce the effect of friction on the yarns, oil is applied through a device located on the spindle head and comprising a tank and a bush that, by capillary action, allows the oil to rise, reaching the yarn contact zone. This operation is carried out before the first twisting stage and using an adjustment nut the quantity of oil can be regulated, bringing different parts of the yarn surface into contact with the distribution bush.

As already mentioned, one kind of two-for-one twisting machine can effect doubling and twisting contemporaneously.

As shown in Figure 64 below, which illustrates this machine, there are two packages on the spindle from which, following separate paths, the two threads are unwound. These are subsequently twisted together.

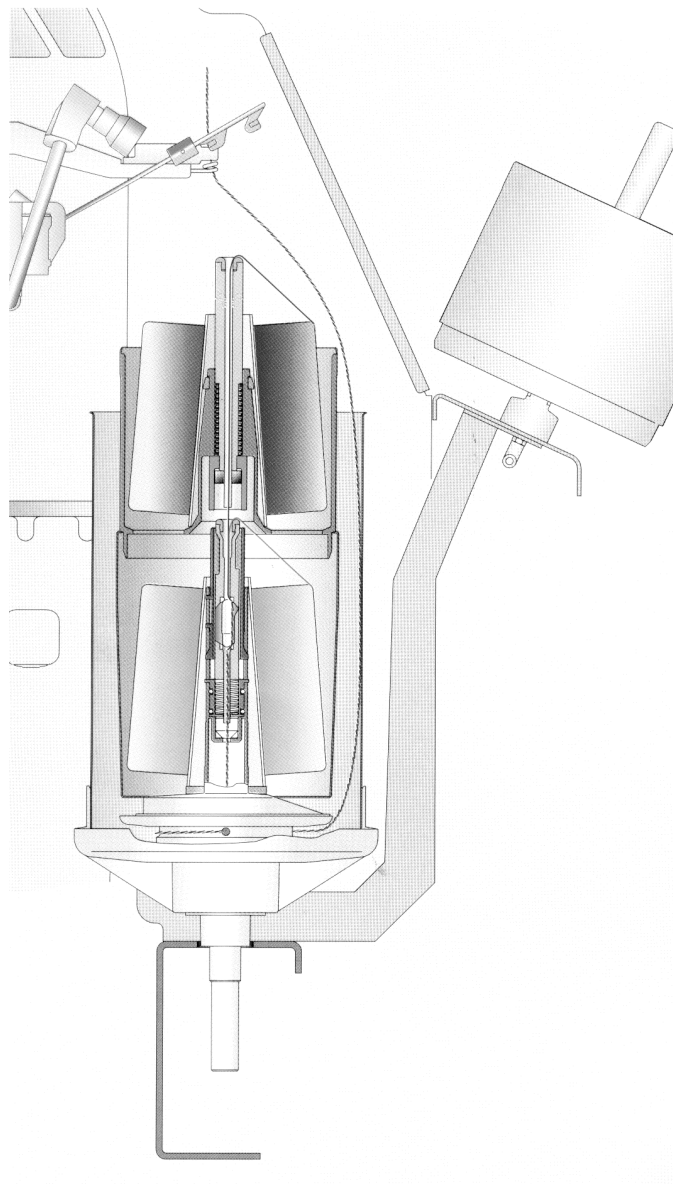

*Fig. 64 One-step doubling and twisting*

## Reeling

Reeling is a skein preparation operation (generally the preparation of skeins prior to dyeing). The reeling machine is fed by yarn packages and winds the yarn onto a reel, thereby forming the skein. Winding can be carried out either modifying the yarn crossing angle or by adjusting the skein width up to 400 mm. The diameter of the reel is normally 54" and it has a speed of 400 rpm. Skeins can sometimes reach 5 kg in weight.



*Fig. 65 Detail of a reeling machine*

## Winding-off

There is one particular type of winding machine that is called a winding-off machine. It is fed by skeins that have just come from the dyeing process and it produces packages.

The winding-off head is basically the same as that of a normal winding machine, while a special system is required to unwind the yarn from the skeins, positioned on the reels, making sure that, when tangles cause yarn tension, the yarn does not break.

This system is a tensioning device through which the yarn passes; if it is too taut, the process speed is reduced to facilitate winding-off, then normal speed is restored. In the event of considerable tension, the device stops the winding-off head and the machine operator undoes the tangle.

The traditional unwinding machine has a non-controlled reel feeding system and can therefore work at speeds of up to only 300 m/min.; the latest machine models, on the other hand, use controlled reel systems with independent electronically controlled motors and built-in brakes that allow the head to be stopped quickly, preventing the yarn from breaking. These machines work at rates of around 600 m/min.

# Automation of Transportation and Packing Operations

## Introduction

By way of completing the spinning processes described in the previous pages, and in order to reflect the textile industry's constant efforts to remain competitive and to go on offering the market high quality yarns at competitive prices, consideration must also be given to the need to automate the end-of-cycle operations.

In the face of the various working conditions presented by today's spinning sector, and given the ease-of-management demanded of automations of this kind, the latter tend to eliminate all the intermediate finished yarn handling stages, thereby relieving personnel of the more repetitive and laborious tasks and at the same time guaranteeing:

- higher plant productivity
- accurate package handling
- high-quality packaging

In particular, in situations in which production volumes are high enough to justify considerable investments, opening up the way for fully automatic systems, it is also necessary to guarantee:

- no style mixing
- high performance from production machinery
- orderly material flows
- reliable handling
- flexible processing cycles

The automation processes relating to machine operation tasks within the mill are not motivated only by the need to keep labour costs down; they also reflect a more complex strategy that can be broken down into the following objectives:

1. better use of staff and reduction of their margins of discretion, so as to optimise distribution of tasks;
2. close adherence to operating procedures, resulting in opportunities to verify processing at any time and in any stage;
3. possibility of increasing or reducing the production capacity of a system or of machines, to suit the workforce and changing market needs;
4. a systematic approach to planned controls and easy classification of products to be handled;
5. foolproof identification of articles handled and recording of all packages dispatched.

Below we give two examples of how these principles can be applied: first in the package unloading, transportation, palletisation and packing zone and second in an automated cell for the packing and handling of packages.

## Package unloading, transportation and packing

The most recent yarn package handling and packing systems allow applications specifically developed both for open-end spinning and for winding.

In the first case, systems – of varying degrees of sophistication – have been developed for the “intelligent” management of open-end spinning machines.



These systems are based on the concept of monitoring the progress of production as a whole, so as to be able to manage doffing occurring contemporaneously on different machines and to optimise sequences without penalising single performances.

Regardless of how many rotors each of the machines in the production line has, automatic unloading of this kind of spinning machine involves the delivery, in the direction of the packing areas, of whole “trains” of packages.

In the second case, while still bearing in mind the need for real-time monitoring of the progress of production, the surveillance systems in operation, regardless how many heads each of the machines present in the production line has, allow the management of *single packages* or *sections of trains*.

In both situations, the groups of packages being delivered, not necessarily being multiples of the final packing module, may need to be sorted by article (yarn count) and stored temporarily, prior to packing (Figure 66).

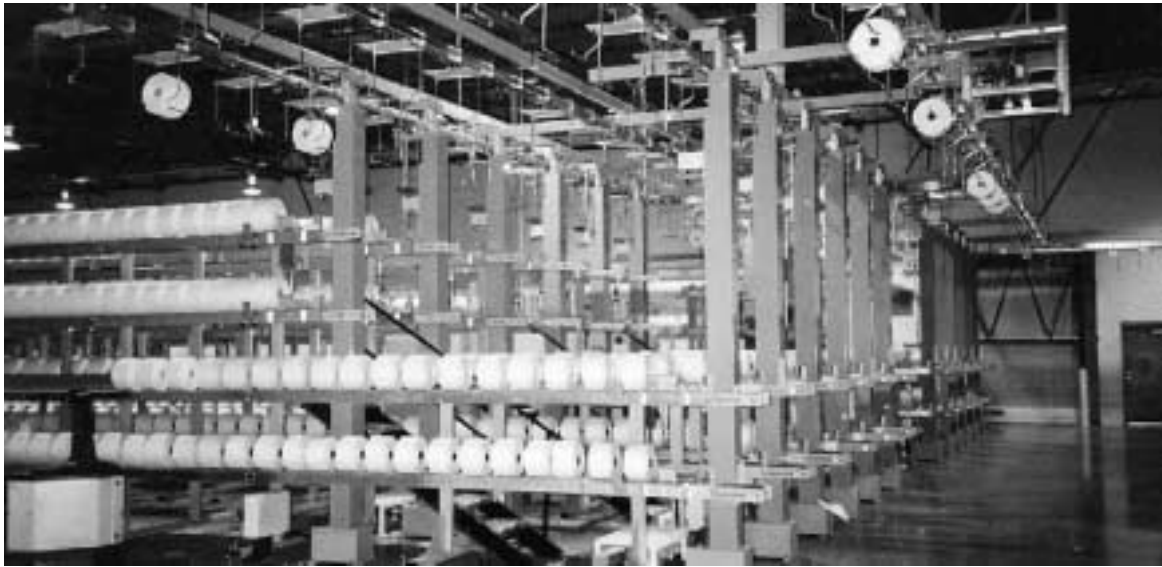

*Fig. 66 Package pre-storing conveyors*

Once the packages have reached the predetermined number, lifters (installed in front of each spinning machine) pluck them – two at a time in the case of open-end spinning machines and singly in the case of winding machines – from the collection conveyors inside the machine and transfer them, oriented as necessary, to the weighing units of an aerial chain conveyor (or alternatively to a suspended collection belt), which runs in front of the unloading points, and conveys them to the packing area.

Correct identification of trains and single packages in transit is fundamental in order to guarantee correct sorting during the final handling stages. This is done by the writing and subsequent reading of magnetic tags on each weighing unit (or, alternatively, by tracking of the trains themselves, a system in which the packages pass in front of a series of photocells that detect and count them).

If the final packing module is a pallet and if it is not possible to install, for each article produced, a sufficient number of pre-storing conveyors to hold the total number of packages needed to complete it, then the packing area will have a number of pallet points – as many points as there are (different) articles being produced in the spinning mill – where the packages are progressively deposited.

If the final packing module is a *box*, then the packing area will have a number of collection conveyors – as many conveyors as there are layer separators – for the temporary storage of the number of packages needed to form a group of boxes.

In certain situations, it is still possible to compensate for the number of packages actually leaving the spinning machine and to make up directly, with the number of packages needed (a multiple of the final packing module to be made up), the pallet or series of boxes required. This is done, thanks to in-line vertical rotary stores, either by storing excess packages or by adding to the existing packages.

The packing units (palletisers or boxing machines) are PC-controlled machines that can handle packages singly or in groups according to the production capacity required of whole system. These machines, entirely automatically, make up the pallets (through the placing of layer upon layer) or fill the boxes with layers of packages.

In palletisation cycles, the pallets that are being made up are conveyed inside the machine by service shuttle or, alternatively, it is sometimes the palletiser itself that moves to the operating area; in the case of boxing cycles, on the other hand, the boxes move independently, on service rollers into the boxing station.

Palletisers are Cartesian robots driven by brushless electric motors. They are equipped with pneumatic single or multiple spindles that pick up the packages, already centred and oriented as necessary, directly from the tube and deliver them, according to the required geometry, in the layer that is being made up (Figure 67).

These robots also insert separators, and handle empty and full pallets.



*Fig. 67 Package palletiser*

Bagging and boxing machines, on the other hand, pack single packages ready to be dispatched in boxes; a sheet of polyethylene wrapping is first conveyed to a wrapping unit, where it is employed to form a tube. It is then sealed in several points to form a bag..

For the subsequent boxing stage, it is possible, through the combined feeding of two motorised conveyors, to assemble a layer of packages arranged ready for boxing

## **Robotised cell for automatic package handling**

This technology is based on the use of anthropomorphic robots equipped with special tools and designed specifically for handling packages. The robot is part of a fully integrated system that incorporates a series of machines and special devices.

The main advantage offered by this solution derives from the robot's multi-purposeness and operational flexibility. Indeed, the robot replaces a series of dedicated machines used in traditional systems, thereby reducing drastically the costs per unit transported.

Technologically, this solution stands out for its high running speed, complete positioning accuracy and maximum reliability.

Autopacking systems – complete systems for draw-twisted yarn packages – exemplify perfectly this new technological trend.

These systems handle packages plucked from transportation carriages. The packages, once identified through special ID disks that a special machine applies to the tube collar, pass through quality control stations, before being automatically bagged and packed in cardboard boxes, which are then sealed and labelled.

The system comprises three main areas:

- Transportation carriage line
- Package transportation disk line
- Empty/full box line

The packages, in the various production areas, are loaded manually onto single-side carriages with 72 slightly angled pegs. These carriages are moved manually to the carriage line entry point. Once they have been fed into the line, the carriages advance automatically until they reach the package picking up point.

Here, there is a hydraulically-operated overturning platform, equipped with carriage anchoring devices. When the carriage is in position, the platform rotates through 85 degrees, positioning the packages so that they are perfectly horizontal and can be gripped from above by grippers located on the head of the robot.

The robot is a six-axis machine with its own control system.

When the packages are in picking position, the head grips 4 packages contemporaneously and then ascends, sliding the packages off their respective pegs.

The robot then carries out rapidly a pre-programmed cycle, depositing the 4 packages on as many transportation disks (on the disk line).



*Fig. 68 – View of the handling and packaging robot*

The cycle is repeated until the carriage is completely empty.

At this point, the platform returns to its rest position; the empty carriage is released and the carriage line starts to move again, pulling the carriage towards the exit from the line.

Should there be another, full carriage already present, this is immediately placed on the platform and the robot starts the unloading cycle again.

The disk line is a group of motorised rollers arranged in a closed circuit. The disks, carrying the packages, are transported around the circuit, passing through the various operating stations.

In the first of these, each package is given a product ID disk. This is applied, by pressure, to the tube collar of the package by means of a special, pneumatically-driven automatic machine. The machine has an 8-chamber rotating drum, and each chamber can contain a different type of disk. Once the disks have been applied, the packages proceed to the visual inspection stations, where an operator enters the relevant data into a terminal linked up with the management system.

In the next station, the packages are passed through a special bagging machine, which slips a protective HDPE (high-density polyethylene) bag over each one.

Once this operation is complete, the packages are ready to be packed. The disk line forwards them to the packing station. Here, the robot transfers the packages from the transportation disks into cardboard boxes supplied by the box line. These boxes are made up, upstream of the box line, by a special box assembler.

The other packing materials (moulded plastic bottom and top plates) are fed by two separate lines to the positions ready for plucking by the robot, which inserts them into the packing boxes in the correct order.

The filled boxes are transported by the box line to a labelling station, and subsequently to a station in which they are automatically closed and sealed.