

5

Carding and prior processes for short-staple fibers

5.1 Introduction

Short-staple fibers are nearly always processed dry using mechanical means. The first stages in a short-staple spinning mill comprise a number of machines, usually arranged in series, which are connected by fiber transport systems. The most common of these transport systems is where air is pumped through large ducts and carries the fibers in the airstream. The line of machines described is called an ‘opening line’ and it supplies a set of cards in which the fiber flows are usually arranged in parallel. There are usually two or more opening lines in an establishment and the space occupied by opening lines is sometimes known as the ‘blow room’.

One function of the blow room is to blend the fibers into a homogeneous product. The term ‘blend’ applies to the mixing of nominally similar fibers or to the mixing of unlike fibers similar to polyester staple fibers and cotton. In the latter case, the blending may be carried out in the blow room or in a process following carding. However, the case being considered in this chapter is that of blending nominally similar fibers. It is possible to blend dissimilar fibers by using the same process as described in this chapter although many operators prefer to do it in processes following carding as will be described in Chapter 6.

Fiber attributes vary from bale to bale and within a bale. Even man-made fibers, in which the fiber length and fineness are strictly controlled, have variations in fiber crimp and finish. Variations of crimp and finish alter the mutual cohesion of the fibers within a strand or clump and these can strongly affect the ease of processing. Natural fibers vary in all of their attributes. In both cases it is very desirable to blend as early as possible in the blow room, and to use every succeeding opportunity to carry on the process of blending.

The primary stage of blending is carried out by removing clumps of fibers from a succession of bales and mixing them in the machines that follow (see Section 5.4). The secondary stage is carried out in a blending machine with the intention of homogenizing the material in transit. Mixing also occurs in every machine in the opening line as well as during transit. Further blending occurs in processes following

carding as will be seen later in Section 6.4 in Chapter 6. All contribute to the degree of fiber homogenization in the total spinning process; however, for now we must concentrate on the blow room.

Raw material is supplied to a mill in highly compressed bales of fiber. One important function of the blow room is to disintegrate these bales into a flow of very small clumps of fiber, which are sufficiently small in size to be digested by the cards. The cards then further divide the clumps into single fibers (or very small groups of them) and assemble them into rope-like strands called 'slivers'. The function of breaking up the bales into clumps, and the subsequent reduction into single fibers, or very small groups of them, is referred to as 'opening'. (Also the term is used as an alternative to 'blow room' but the context usually makes it clear which meaning is intended.)

A third function is needed for natural fibers, the most important of which in short-staple spinning is cotton. As was discussed in Section 2.2.1 in Chapter 2, cotton ginning is imperfect as far as removal of the trash is concerned. Ideally, unwanted matter must be removed so that it neither interferes with operations nor causes significant deterioration in the quality of the product. In practice the ideal is not reached but modern technology allows a close approximation to it. The mechanical cleaning function is not required when spinning 100% synthetic fibers, but many mills have this broad capability irrespective of the fiber actually being spun; this gives them operational flexibility.

Recombination of fibers into a larger mass occurs at various stages along the opening line and I will call this phase 'condensation'. Such condensation is necessary to accommodate the control of the fiber flow in a continuous line and to aid the processes of accumulating fibers to make the feed systems workable. Feed systems often use moving lattice aprons to collect fibers deposited from streams of air or gravity feeds. A lattice apron is an endless permeable belt of slats, each of which is positioned perpendicular to the line of the belt movement, but parallel to one another. Air is often sucked through the gaps between the slats. The slats contain metal spikes to retain the fibers. A rotating condenser is a perforated cylinder, to which suction is applied so as to collect fibers from an airstream. The process of condensation is really a form of doubling (see Section 3.10.1), which improves evenness along the fiber stream. The word 'stream' is meant to include airborne fibers flowing in ducts, thick blankets of fiber (called batts or fleeces) being carried by mechanical transport mechanisms (such as lattice aprons), and sliver being delivered from the cards.

It is impossible to blend the fibers into an intimate blend without opening them first. A perfect intimate blend would have a single fiber of one sort in very close proximity to single fibers from each of the other sorts. Imagine trying to blend clumps of fibers of, say, 1 cu ft in size into a homogenous product. It would be rather lumpy and the blend would hardly be characterized by the word 'intimate'! Also, adequate cleaning of natural fibers is not possible without opening the clumps first. In the case of cotton fibers, it is relatively easy to remove the trash and dust from the outside of a clump but it is much more difficult to remove spiky trash or even dust from inside without damaging the fiber. With so-called cleaning machines, there is, of necessity, a great deal of opening and a certain degree of blending. Dust and trash has to be removed from the bale plucking machines. Dust and trash is ejected from blending machines, the main job of which is to accumulate fibers in reservoirs to facilitate blending, as discussed in Section 5.4. Dust and trash is removed from so-called opening machines as the clumps are divided. Consequently, each machine in the opening line performs functions of blending, opening, and cleaning in varying

proportions. Thus the processes called opening, cleaning, and blending should be regarded as various phases within the operation of each machine and this is distinct from the labels applied to the machines. However, a major point of this paragraph is to emphasize that the labels applied to individual machines in a blow room describe their major function; all the machines perform all three functions but to varying degrees.

Cards are included in this analysis because they share many of the functions of the preceding machines, and they are physically part of the modern linked system for performing the processes described. The whole system described in this chapter is integrated. Bales of fiber form the input and sliver is the output. In most modern systems, the fiber is untouched by human hand from the time that the bale is placed into position in the bale laydown until the sliver emerges from the card. It is now a continuous operation and there are few demands on labor. Such a system is known as a chute feed system because the fiber is fed to the card by way of a 'chute'. (A chute is really a temporary storage chamber that contains automatic flow control devices to maintain the linear density.) Any failure to control at this point would eventually result in exceptionally long-term errors in the yarn. Errors in the yarn arising from this cause are so long that they extend over the mass of yarn on many consecutive bobbins. Once the bobbins become mixed with others, the error appears as a random count variation. Consequently, flow and control will also be discussed later in Section 5.9.

This chapter will be written using imperial units common in the USA and many other English-speaking areas. However, metric conversions will be given but in a paragraph with several such conversions, they will be gathered at the end of the paragraph to minimize distraction to the reader.

5.2 Opening line

5.2.1 The elements of the chute feed system

The elements of a system are shown in Fig. 5.1. The diagram is deliberately incomplete because the space in the diagram was at a premium and the intention was to give an

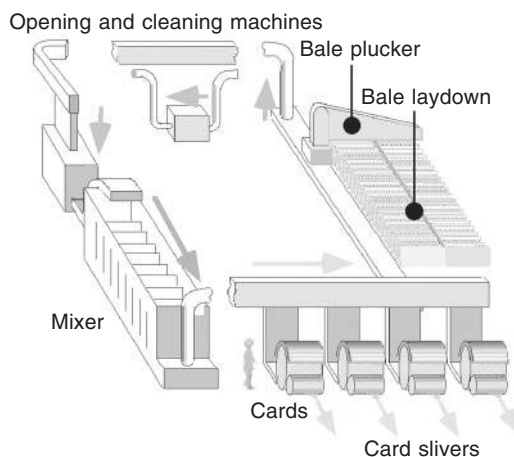

Fig. 5.1 Elements of an opening and cleaning line

impression rather than a prescription. The actual machines installed are determined as a matter of operational need and preference. For example, the blending machine is shown as being the last in line before the cards on the basis that the best blending is achieved when the fiber clump size is very small. However, some prefer to install it earlier on the basis that good blending aids the processes of opening and cleaning. Some use more than one blending machine per opening line but the extra cost of the machines is sometimes hard to justify. Only four cards are shown in the diagram but in an actual plant there are several times this number; the actual number is determined by the relative productivities of the cards and the bale plucker (the device that removes clumps of fibers from the lines of bales). There are usually two or more opening lines, because this permits a shutdown of one for maintenance, adjustment, or other purpose without closing the whole mill. In similar vein, the ductwork for the machines has not been joined up to emphasize (1) that a variety of ductwork transition pieces are needed to complete the fiber flow circuits and (2) that bypasses are often fitted which require flap valves and forked ductwork.

Safety is a special concern in the work zones about to be discussed; consequently a special Section (5.12) about such matters has been added to the chapter.

5.2.2 The historical perspective

Szaloki [1] points out that there were few changes in the design of opening and cleaning equipment in the first half of the twentieth century. There was then a surge in development spurred to some extent by the increased need to clean the cotton as it increasingly became picked by mechanical means. He gives a review of opening and cleaning equipment as of 1976. Remarkable progress was made during the last century in developing means of connecting discrete machines into continuous production systems. A good example is the blow room just described. At the beginning of the century, it required many workers to control and transfer material from machine to machine in the series.

5.2.3 Conservation of flow

Opening and cleaning machines have to be connected in such a way that matches the productivities of the various components. Since the machines in an opening line are all connected, mass flow has to be conserved. The conservation includes not only the fibers flowing into and out of any element, but also the trash and dust removed. In other words, what goes in should come out! Appropriate fiber transport systems have to be provided so that a continuity of fiber flow and control can be maintained. Also there has to be a distribution system that connects a series of cards in parallel to the supply system. The change from a series path to a set of parallel paths is needed because the equipment in the series path has a much larger production capability than the individual cards in the parallel paths.

5.3 Bale preparation

5.3.1 Selection of bales from the warehouse

An intimate blend starts with the selection of an appropriate number of bales from large lots in the warehouse. Lots are usually segregated to provide compatible content,

and a bale withdrawn from a lot should have, in theory, similar attributes to the rest of the bales in the lot. In fact, there are large variations and part of the art of blending is to arrange the assignment of bales to the various lots in a way that minimizes the variance within the lot. The bales withdrawn are arranged in sets to make a laydown as described in Section 5.4.

5.3.2 Opening (the process of removing straps and bale covers)

Bales arrive at a mill in a compressed state and they are protected by a covering and stored in a warehouse. The bales are moved to the work area a day or so before they are needed, the straps and the coverings are then carefully removed, and the bales are allowed to condition. The bales are said to be ‘opened’. (It will be noted that the term ‘opened’ takes on a different meaning from that defined earlier and care has to be taken to make sure of the context of the word.) Removal of the straps can be dangerous if not carried out with proper equipment because when the straps are cut, they relax violently and injury could result if due care is not taken. Failure to completely remove the bale coverings can lead to the inclusions of ‘foreign fibers’ that produce faults in the yarns and fabrics. (Removal of the last vestiges of the covering from the underside of a 500 lb (\approx 227 kg) bale is not easy.)

5.3.3 Bale conditioning

The conditioning just mentioned allows the moisture content and temperature of the fiber to approach stability. The bales, freed from the restraints of the straps and bindings, expand and they are said to ‘bloom’. Bale blooming is a natural process in which the bale grows in size as the stresses in the fiber, arising from compression, release themselves. Conditioning not only allows the moisture content of the bales to approach equilibrium but, in cold weather, eliminates condensation of moisture on the cold fibers. Damp fibers are difficult to process. At the other extreme, excessively dry fibers are subject to being damaged.

The storage environment should be at about 70°F (21°C) and the rh at roughly 45%. Care should be taken to avoid storage of cotton in freezing conditions otherwise the strength of the fibers will be reduced permanently. A conditioning curve for a typical bale is shown in Fig. 5.2, which shows how the density of a typical bale might take several days to reach a stable state after the straps have been released.

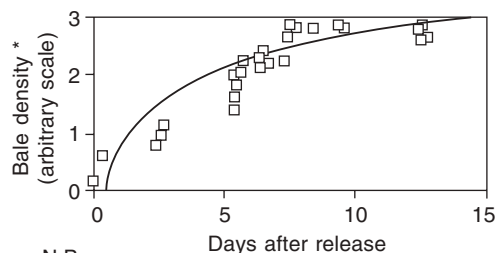

N.B.

* Bale density was measured by penetrometer

Fig. 5.2 Bale density changes upon releasing the straps

5.4 The first stage of blending and opening

5.4.1 The bale laydown

Two or more parallel rows of conditioned bales are laid on the floor in proximity and this is called a ‘bale laydown’ as was sketched in Fig. 5.1. The overall purpose of opening is to break down the supply material into an open mass of very small clumps of fiber that can be handled at carding. The word ‘opening’ is used here in a different sense from that described in Section 5.3.2. The first step is to remove clumps of fiber from the bales and this is referred to as ‘bale milling’ or ‘bale plucking’. A bale is a tightly packed mass of staple fiber usually weighing about 500 lb (≈ 227 kg). Several packing densities are used to yield so-called flat, standard, and high density bales. Mills within the USA use standard bales but high density bales are used for transoceanic transport to conserve space and cost. Flat bales are of low density and are used by mills close to a gin. It is desirable to allow the bales to bloom sufficiently and to choose bales of the same relaxed size. Otherwise the first cuts from the bale laydown will not be according to plan.

Bales are supplied from the warehouse in carefully selected sets designed to minimize variations in the fiber attributes. To these bales, others containing recycled fiber are often added. However, the number of these should be strictly limited if quality is to be preserved. Each bale should be inspected for fragments of wrappers or wire before they are assembled into a laydown.

Bales should be assembled so that they are in close proximity to their neighbors in the laydown and similarly oriented to create a compact mass of fiber suitable for the bale plucker operation. Care should be taken to keep the height of the bales similar.

5.4.2 The bale plucker

The first mechanical processing stage commonly used in the mill today is a patrolling ‘bale plucker’ or ‘bale milling machine.’ Sets of rotating spikes or teeth are used, which cut into the operational surfaces of the laydown in a manner similar to that shown in Fig. 5.3(a). A typical cutter and associated press rolls are shown in Fig. 5.3(b). The press rolls are to keep the bale surface firm at the time of cutting. Most

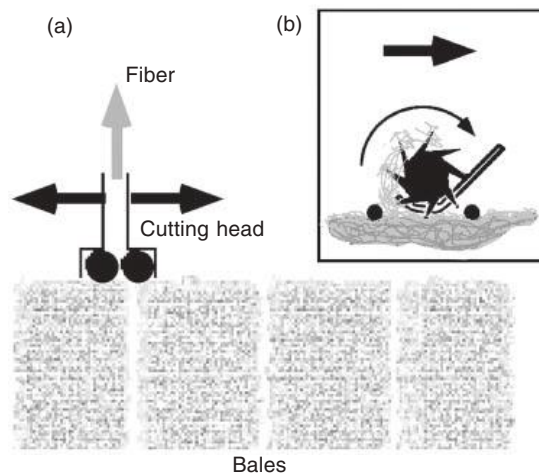

Fig. 5.3 Milling a bale laydown

machines use at least one pair of cutters. Often the other one in a pair is a mirror image and rotates in the opposite direction. Some machines cause one of the cutters to lift in order to balance the offtake of fiber between the cutters. The changes occur at each reversal of the bale cutter head (at the ends of the bale laydown). Some makers stop the trailing cutter because the teeth are facing the wrong way. The depth of cut is an important parameter in determining productivity and degree of fiber separation. A setting more than, say, 0.2 inches (5 mm) might cause the top surface of the laydown to become roughened with fiber tags. These tags are torn off in the next pass to form unacceptably large clumps of fiber in the offtake. The theoretical minimum number of bales in a laydown is determined by the adequacy of the blending equipment and the diversity of the fiber characteristics from bale to bale. Currently the maximum set by machine design is about 50 bales but improvements in the technology of bale milling and blending will increase that value. In practice, the number of bales is set to give a work schedule that is suitable for management of the personnel and minimizes costs. The greater the number of bales in the laydown, the fewer the number of laydown changes and the lower the cost of operation. Also, the use of bale pluckers that deliver fibers in small clumps contributes greatly to the solution of the problem of opening. The clumps at this stage should be the largest in the system and the spikes or teeth that temporarily grip the clumps have to be proportionate in size.

It is desirable that bales in each laydown should be of similar size and density. If they are not of the same height, the first cuts will differ in composition from later ones. If they are of different density, the blend make-up in the output will not always be as predicted from the initial bale data.

5.5 The process of disintegration of fiber clumps

5.5.1 Opening (the process of division of fiber clumps)

In the stages of the opening following the bale plucker, machines with an opening function have the task of separating clumps of fiber into smaller ones. The sizes of the clumps, and of the teeth that deal with them, are progressively reduced. In general terms, grasping clumps of fibers with sets of teeth and dragging the clumps across another set of teeth or grids perform the opening function. The engagement of a clump with two sets of teeth in which there is relative movement applies a shearing action that pulls the clump apart. Since this process alone cannot be seen in any machine, and the design of the machine is affected by the other processes it has to perform, further discussion of the machine design will be deferred.

Most machines have feed rolls and toothed elements that are significant drafting systems. Fibers are caused to slide over one another as fiber clumps are divided and the resulting daughter clumps or single fibers are removed. The divided fiber clumps, fibers, and non-lint material are carried to the next machine by the airflow and the material is discharged into a receiver that might be a chute feed, condenser, or the like. The receiver has a doubling function as will be discussed in the next section.

5.5.2 Specific volume of the fiber stream

The specific volume of a bale varies. However, the changes are dependent on the fiber characteristics, the original bale density and the atmospheric conditions prevailing

at the time the bale is blooming. The specific volume of the bales at the time the bale plucker is removing clumps affects the size of the fiber clumps and the performance of the downstream machines. Thus bales should be opened at least a day before they are put in a laydown.

Of course, the specific volume of the fiber is much higher in transit through the pipes connecting the machines because the fiber clumps are dispersed in air. It also decreases during condensation at the collection points at each mechanical feed system. Every time the material is further opened, the specific volume increases and these changes have to be taken into account in calculating pipe sizes, feeder speeds, and so on. The degree of fiber openness also affects what sort of cleaning is effective.

5.5.3 Maintenance of the machine elements

The working elements of the various machines such as beaters, grids, etc., must be kept in good condition and should be properly set. If the elements in contact with the fiber become bent, nicked, or otherwise damaged, the fiber is likely to be damaged. Fibers may collect and clog the machine, and neps may be produced. (Neps are tiny balls of fiber that degrade the appearance of yarn and show up strongly on the surface of fabric. Unfortunately neps often dye to a different shade; this emphasizes their presence and reduces the value of the product.) As was noted earlier, the size of the machine elements gets smaller as the fiber passes downstream in the process line. This makes them more vulnerable to damage and increases the likelihood of producing fiber damage especially if they are not properly maintained and set. Furthermore, where the relative velocities are high, the abrasion of the metal surfaces increases. A major purpose of the opening line and card is to reduce clumps of fiber to single entities. Sufficient working is needed to do this but excess working can only damage the fiber, produce nep, and remove useful fiber mass. Careful assessment is required to make sure that there is only just sufficient opening and cleaning.

5.6 Condensation

5.6.1 Feed arrangements of the various machines in the opening line

The fiber stream is carried through some machines purely by the flow of air (e.g. the axiflow machine in Fig. 5.4(a)) but in others, a mechanical feed is used. The fibers and the air have to be separated to allow a mass of fibers to be advanced by mechanical means into the working area of the machine concerned. The first sort needs no explanation as far as the feed is concerned. The latter does need some explanation.

5.6.2 Accumulation of fibers at the feed

As mentioned earlier, the process of separating the fibers from the air and the accumulation of fibers on a surface is called condensation.

An example is the weighpan feeder (Fig. 5.5), which uses lattice apron feeds. The lattice apron is a permeable 'belt' on to which fibers are collected and the air passes through the belt. Another example is a rotating 'condenser', which collects fibers on the inside of a porous drum. Dust from the fibers is pulled through the perforations to be carried away by suction. A fiber take-off system is applied to the outside surface to keep the quantity of fiber on the surface at a given level. The openings in the lattice

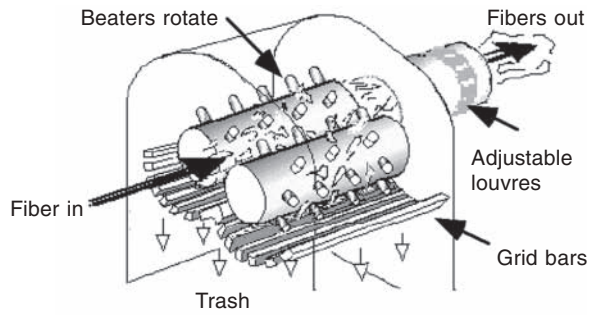

(a)

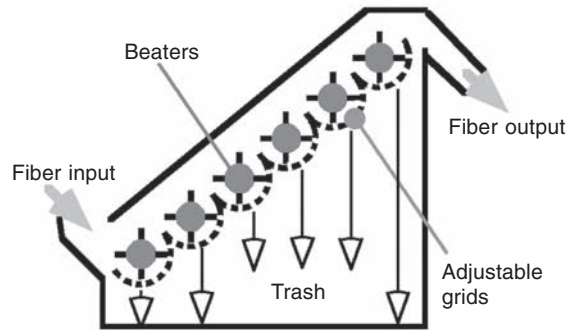

(b)

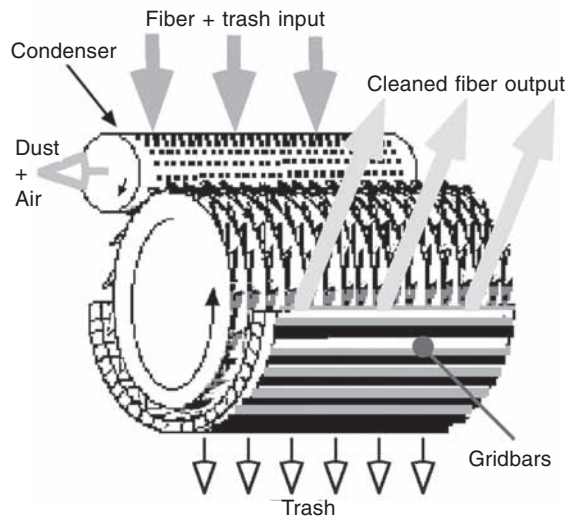

(c)

NB Drawings not to the same scale.

Fig. 5.4 Fiber cleaners

apron are fairly large and the size of fiber clump that can be captured is also fairly large. On the other hand, the openings in the condenser surface are small so that small clumps and single fibers can be collected on the outer surface.

As mentioned earlier, the process of accumulating many layers of the incoming fiber causes an appreciable degree of doubling. It will be recalled from Chapter 3 that the term ‘doubling’ implies a considerable diminution of the unevenness in the material

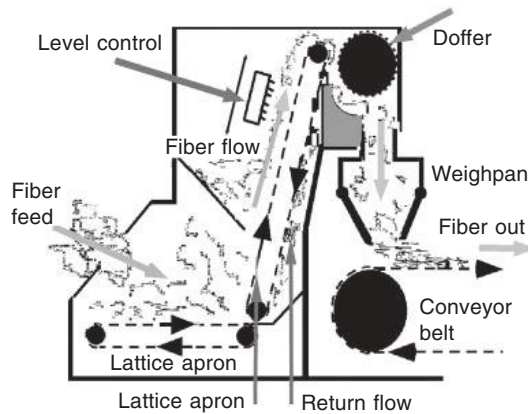

Fig. 5.5 Weighpan feeder

collected on the collection surface. Thus, there is an improvement in the short-term evenness of the product at that point. (However, after the material passes through the subsequent machines, the error assumes an ever longer wavelength, and in the yarn it will be seen as a very long-term error.) The doubling just mentioned tends to hide the unevenness produced by the opening processes.

Fibers and fiber clumps are attracted to the outer surface of the condenser just described. Perhaps what is more important, fibers are attracted preferentially to the thin spots in the fiber mat lying on the screen because more air flows in these zones. Conversely, there is less airflow to the thick spots and the rate of fiber flow to these thick spots is reduced. Thus, there is an automatic regulation effect.

5.6.3 Mechanical feeds

The previous paragraph dealt with lattice aprons as condensers, but they also fulfill another function. They serve as transport systems that move the fiber from place to place. They often serve as a means to project fiber clumps into a stream of air. (The airstream is, of course, another means of transport.)

A second mechanical system is to use a pair of rolls to grip the incoming fiber and feed it forward. The rolls may be pinned or fluted and they have to be set at a distance apart that will entrap the incoming fiber and not jam up or choke.

A third mechanical feed system is to use fluted or pinned rolls. The rolls engage a batt of fiber and induce it to slide over a smooth surface. Figures 5.8 and 5.10 relating to chute feeds often used to supply fiber to a card will be shown later.

5.7 The process of cleaning

5.7.1 Philosophy of cleaning

Natural fibers, in the state that they reach the mill, have mineral and vegetable particles lodged between them. With cotton, there are often seed coat fragments attached to them. It is difficult to remove some of the extraneous matter without vigorous mechanical action and without adequate opening. Every time a clump of

fibers is divided, a new surface is exposed from which it is relatively easy to remove the loose unwanted matter (trash) but trapped or bonded material is a different matter. The machines in the opening and cleaning line are intended to remove waste but the amount of waste in the raw material is quite variable. At one extreme (man-made fiber) the waste is very low. At the other extreme, with some natural fibers, there might be as much as 10% (or even more) non-lint material. There might also be some unwanted nep-prone fiber.

As was discussed earlier, cleaning nearly always accompanies an opening function. As the material is opened, the specific volume of the fiber mass changes considerably. To maintain an approximately constant mass flow of fiber through that process phase, the mean velocity has to increase. Imposing such acceleration on the moving fibers is really saying that the flowing material has been drafted.

Although it seems obvious, the material removed during cleaning must not be allowed to re-enter the fiber stream. This is because, not only would it be inefficient, the material removed would contain fibers damaged by the cleaning operation, and which might cause extra problems in subsequent processing.

5.7.2 Various means of cleaning

There are several ways in which fiber can be separated from trash.

Newly removed fiber is removed from the bale plucker by an airflow running at perhaps 100 ft/sec (30 m/s). A substantial stream of air carries the fiber to the next machine. It is usual to have a magnet in the air duct that can remove ferrous materials from the flow and thus reduce damage to the following machines from these foreign objects. The magnets are sometimes called 'humps' because of their unusual geometric arrangement. Also some operators use pneumatic separators that throw out non-ferrous foreign objects, as sketched in Fig. 5.6. (The sketch is based on sales literature of Trützschler GmbH & Co, Germany, to whom acknowledgments are made.) Heavy particles are thrown out because air is forced to flow in a circular direction; air and fiber are sucked back into the airstream but heavy particles such as wood and stone are ejected. It is surprising what is sometimes found in bales of fiber!

In Figures 5.4(a) and (b) it will be seen how the exposed surface of a clump of fibers is gripped by pins or teeth and dragged over one or more edges formed by grids to remove trash. The trash drops through the slots and the fibers go on their way. Grid bars or screens are used in several places in the opening line and in the card. It must

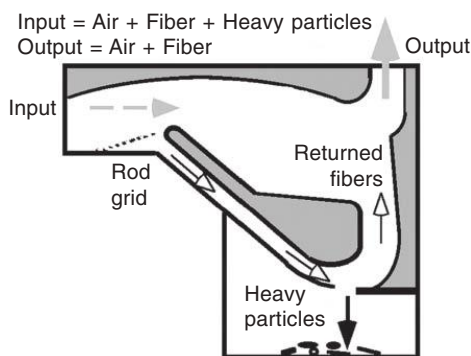

Fig. 5.6 Heavy particle removal

be appreciated that with cotton, the trash particles are often attached to the fibers and it is not easy to remove all of them. As the fiber is worked, trash tends to become separated from the fiber and it is necessary to have a fairly large number of cleaning points to be effective.

As was explained earlier, the fibers are usually gripped in these machines by using saw-like teeth (Fig. 5.4(c)) or pins. The pins can be very large such as those used in the cleaners shown in Fig. 5.4(a) and (b) or they can be very small as in the case of pinned rollers used for improved fiber separation. These latter pins are commonly conical in shape with sharp points and they are more susceptible to damage than the others. Also the more aggressive action makes fiber breakage more likely and it is important the fiber clump size be reduced as much as possible before entering the machines equipped with fine pins. The saw-like teeth are similarly used where the fiber clump size has been reduced. The saw teeth are used extensively in carding.

Some machines include one or more perforated screens to which suction is applied for the purpose of removing some of the dust and fine fiber particles. In some other machines, a rotating condenser collects fibers from an airstream on its outside surface and dust from the fibers is pulled through the perforations to be carried away by suction.

Another way in which fiber can be separated from trash is to use the differences in mass and air drag between a fiber and a trash particle. This is rather like the method used by the primitive farmer who winnows the chaff from the corn by allowing the wind to carry away the chaff. The fibers and the trash particles have different trajectories that permit separation.

A batt of fibers may be beaten and/or vibrated to cause unwanted particles to filter down through the mass so that the unwanted material can be removed. However, hard, spiky, or attached particles do not respond to this treatment unless they have been crushed and/or abraded in a prior operation so that they become detached or less spiky than they were. The thicker the batt or the more dense the clump of fibers, the more difficult it is to remove the trash. Effective cleaning in this way cannot be carried out until the fiber is well opened. Many machines are effective in removing the dirt on the surface of a tuft; they are less so in removing dirt from the center of the clumps.

5.7.3 Some examples of cleaners

Pre-cleaning machines are sometimes inserted first into the line to divide the clumps and removing the worst of the trash. In the case of the 'axiflow' machine shown in Fig. 5.4(a), there is only that overall drafting which is caused by any acceleration of the fiber stream. However, the tearing apart of the clumps provides drastic local episodes of drafting. The main emphasis is that of removing trash from the outside of the fiber clumps. An adjustable louver, or some other air control device, is provided because it is important that the air pressure should be balanced across the grids. Lack of proper pressure balance can cause newly released trash to be reintroduced into the main fiber stream, or more usable fiber is taken out with the trash than is necessary. If there are local zones of low air pressure, trash can be sucked back into the main flow. To this end, it is important to make sure that access doors and hatches are properly closed during operation.

The inclined cleaner shown in Fig. 5.4(b) provides multiple stages of cleaning with the first stage usually being the most effective. The type of cleaner mentioned

in this paragraph is used at the beginning of the opening line where the size of fiber clump is relatively large and there is a need to guard against too violent an action because it would damage the fiber. Each case has to be judged on its merits depending on the quality level being sought.

The type of cleaner shown in Fig. 5.4(c) is used in later stages where the clump size has been reduced and the more aggressive parts of the working elements (i.e. the teeth) are less likely to cause fiber damage because of the openness of the material being worked. The degree of cleaning has to be balanced against the cost of the fiber removed, remembering that fiber costs are about half the total cost of the yarn.

5.7.4 Maintenance of cleaning machines

Cleaning machines work in a hostile environment. When working with man-made fibers, abrasion can be caused by the fiber finish or even by the fibers themselves. With cotton, much of the dust is silica (or other minerals) from the soil in which the plants were grown and abrasion of the components of the cleaner is increased by its presence. Similar remarks apply to other vegetable fibers. In the rare cases where short-staple animal fibers are used, accumulations of grease or other material tend to clog the machine.

In the various cleaning and opening machines, distances between co-operating surfaces have to be set to control the material. As already mentioned, it is desirable to get as small a tuft size as possible without impairing productivity or damaging the fiber. As elsewhere, good maintenance is required to make sure that beaters and grids do not become nicked or worn because such damage can damage the fiber and cause increases in nep level, both of which reduce the value of the yarn.

5.7.5 Fiber handling

Fiber handling is a term that encompasses not only transport of the fibers, but also the condensation, cleaning, and control of the fiber flow.

Transport of the fiber is usually by a pneumatic system that carries fiber from the bale plucker or weighpan feeder to the following machines, between adjacent machines in the line, and eventually to the chute feed that condenses the fiber before carding. This involves the use of high volume fans that generate the pressure difference to create the flow of air. Sometimes the fiber passes through the fan blades, in which case there is danger of fiber damage and nep creation. Sometimes the fan is at the receiving end and a condenser is used to collect the fiber and allow the filtered air to pass to the fan. The design and installation of the air ducts have to be carried out with care because sharp bends and joints that create turbulence can cause nep. Also jagged metalwork, protruding screws or the like can create fiber strings that are very difficult to separate in later processes. A 'string' is created by a clump of fiber being caught up by some projection in the ductwork, twisting in the wind, and trapping more and more fiber as it lengthens until it looks like a piece of thick string. Fiber strings then break off intermittently to produce material that is difficult to divide without fiber damage and is liable to produce chokes.

Machines along the process line often have a sort of chute feed that not only condenses the fiber but also regulates the flow by mechanical means. A discussion relating to flow and regulation is given later.

In general, the chute contains some device to measure the height of fiber in the

chute and some means of controlling the packing density of the fibers in the column. Vibrating front plates, airflows, and careful geometric design are elements often employed to maintain the packing density. Once that is maintained, a simple volumetric control of the fiber feed suffices.

It might be realized that machines with beaters and saw-toothed coverings are extremely dangerous if left unguarded. In many countries it is a legal requirement to provide proper interlocked guards that will cause the machine to stop if removed. Also remember that most of the machines are heavy and the inertias involved do not permit them to be shut down quickly. Not only are the safety requirements legal in nature but there must also be a strong commitment by employed and employers alike in the matter of safety if accidents are to be avoided.

5.8 Intimate blending

5.8.1 The consequence of poor blending

Fibers may be blended in a mill by either mixing them together before carding or by running several slivers of each sort in a creel of a drawframe or other sliver processing machine. The former process is referred to as ‘intimate blending’ and the latter as ‘creel blending’. Creel blending might be carried out at the drawframe or the comber but we must defer that discussion until the next chapter. For the purposes of initial explanation, it is useful to consider an intimate blend of two fibers, say polyester/cotton. If the fiber tuft size is too large, the card web will contain streaks of 100% polyester or 100% cotton, and these streaks appear in the sliver. Even with nominally similar fibers, streakiness will exist. Certain fiber characteristics will exist as streaks in the card web just in the same way that the streaks of polyester or cotton had appeared. Thus it may be seen that clump size in the feed to the card is an important factor in following stages of production.

Next consider bales of all the same nominal type of fiber. Despite being of the same type, there are differences in fiber attributes from one bale to another. During opening, fiber is taken from sets of bales. These sets are set in sequence along the laydown. Concentrations of fiber from a given bale set might not be completely dispersed among the rest by the blending. Variations arising from the bale-to-bale changes in fiber will then appear in the sliver produced.

There has to be a substantial element of mixing in the opening line to make sure that the fibers from the original bale laydown are properly homogenized. Failure to do this produces results similar to those just discussed, except that the size and distribution of the streaks are on a larger scale. Difficulties do not appear until the yarn is made up into fabric, at which time so-called ‘dye streaks’ and ‘barré’ occur. Streaks of fiber that do not match the neighboring areas of a fabric can produce an effect very disturbing to the user. If the streaks are long enough, they appear as bands. Also if cones of yarn have different properties from others in a lot, this too will produce bars in the fabric. This is called barré. Such faults in the fabric are common causes of customer complaint with the responsibility being laid on the yarn maker; the settlement of such claims can be very costly.

5.8.2 Coefficient of variation (CV) as a measure of blending efficacy

(Efficacy is used in the subheading rather than efficiency because the latter is difficult to define, as will be realized from the following text.)

Before launching into explanations concerning variation, it might be useful to define some textile measurement terms. The fiber attributes quoted in Tables 5.1 and 5.2 are commonly used in the cotton industry and they are listed below.

- MIC = Micronaire (a measure of fiber fineness)
 This is an old measure of fiber fineness analogous to linear density, which is still widely used in the cotton industry. The values used to be quoted in the unlikely units of mg/inch but they are now regarded as just indexes. It is really a measure of permeability of a wad of fiber in a specified enclosure as described in ASTM standard D1448.
- UHM = Upper half mean length (inches)
 The population of fibers in a sample may be divided into those longer than average and those shorter. The short fibers contribute little to the strength of a yarn. The long ones make more than a proportionate contribution to strength. The mean of these long fibers yields a single figure of merit that gives an idea of what useful length is available in the lot of fiber that was sampled.
- STR = Fiber tenacity (gf/tex)
 This is an old standard definition of normalized fiber 'strength' or 'tenacity', which is still in use. The new standard is in terms of mN/tex. A tenacity in gf/tex is multiplied by 9.81 to get it into mN/tex.
- ELO = Fiber elongation at break, %
- R_d = Fiber reflectance determined by a Nickerson-Hunter colorimeter according to ASTM standard D2253
- SFC = Short fiber content (%). The length of these fibers < 0.5 in (12.7 mm)
 +b = A measurement of fiber yellowness determined by a Nickerson-Hunter colorimeter according to ASTM standard D2253
- CGRD = color grade, which determines the grayness of the fiber
- Area = Percentage of a test surface covered with trash removed from a sample of cotton under standard conditions.

If a blend were perfectly homogeneous, there would be no variation in the fiber attributes over any number of samples. Clearly the blend cannot be homogeneous if any, or all, the various fiber attributes such as micronaire, length, etc., vary over the set of samples. Variations in fiber attributes tend to be independent; the value of CV of one attribute is not necessarily reflected in the others. Often, color grade and short fiber content of the sample have very much higher CVs than the rest of the attributes. The blend is usually significantly worse concerning short fibers than the upper mean length of the fibers (UHM). Most notable is the tendency for most CVs to decrease in the opening line and then increase again in subsequent processing. In the opening line there are large drafts but there is always a compensating amount of doubling in the mixer, chute feeds, and the like. There is also removal of some undesirable matter. In the case cited in Table 5.1, it will be noted that the trash and dust levels fell markedly in the opening line as, of course, they should. There is often a slight rise in CVs between the bale and card sliver. In post-carding stages of drawing, the draw and doubling ratios are usually roughly equal and there is little removal of material even though the CV might be relatively high.

Nevertheless drawing still tends to reduce the trash and dust content but it often causes slight increases in the CVs for the other fiber attributes. Such a result was found by El Mogahzy [2] in an industrial case study. He also found that variations in

Table 5.1 CVs of fiber attributes at various stages

	MIC	UHM	STR	ELO	Rd	Trash/g	Dust
Bales	14.4	5.0	8.3	12.1	6.3	87	73
Chute feed	2.4	1.7	5.5	6.3	1.1	16	51
Card sliver	3.1	1.3	3.8	5.0	1.2	28	28
First drawing	2.1	1.4	3.3	5.5	1.6	24	27
Second drawing	2.9	2.1	3.5	6.2	1.5	24	8

color grade were highly significant in the particular case (see Table 5.2). Space precludes inclusion of all the data available. It can also be seen that the within- and between-bale CVs were comparable and that implies that control of the bale laydown quality is imperfect if no account is taken of the within-bale variance. Normally bale selection is based on two or three samples per bale and this may be insufficient in some cases.

5.8.3 Intimate blending

As was mentioned earlier, the first step is to assemble a bale laydown, and the number of bales in a laydown is usually determined by the operational need to run without replenishment for a round period (commonly 24 hours). The physical arrangement is that which is best suited to enable the bale plucker to remove fibers layer by layer. Once prepared, the bale plucker is set in motion and starts a flow of fiber into the opening line. The cutting head usually moves to and fro across the top of the laydown and the height of the head above the ground is progressively decreased after every traverse. The depth of cut is thus determined. The depth of cut and speed of traverse of the bale plucker decide the degree to which the material is separated into tufts. Both of these parameters affect the productivity of the machine and the size of the fiber clumps generated. There are other schemes for taking fibers from the bale supply but space precludes further discussion.

Once a stream of fiber clumps is established, there are several ways to homogenize the flowing material. Apart from the mixing created as the fiber stream passes through each of the machines already described, there is normally a blending machine, whose main function is to homogenize the flowing fiber. A typical machine of this sort is a sandwich blender in which fibers are laid in layers on surface AA as in Fig. 5.7(a).

Table 5.2 A selection of CVs of fiber attributes

Bale no.	2	3	4	6	7	8	9	CV (%) between bales
MIC	2.4	2.3	2.1	2.2	1.8	2.1	2.0	3.3
UHM	1.3	1.4	1.3	1.5	1.2	1.2	1.2	0.7 in
STR	5.0	4.2	4.2	4.7	5.1	3.9	4.4	3.1 g/tex
ELO	6.3	6.6	7.8	5.3	6.0	5.3	7.4	4.7%
Rd	4.2	4.9	4.4	4.4	4.3	4.2	4.6	4.6
+b	4.1	6.0	4.9	5.0	5.1	4.3	4.5	4.8
CGRD	38.2	43.0	35.8	38.4	38.6	42.1	46.6	–
Area	106	110	99	104	131	132	133	– %
SFC	19.4	15.4	14.9	14.4	14.6	13.2	12.8	11.1%

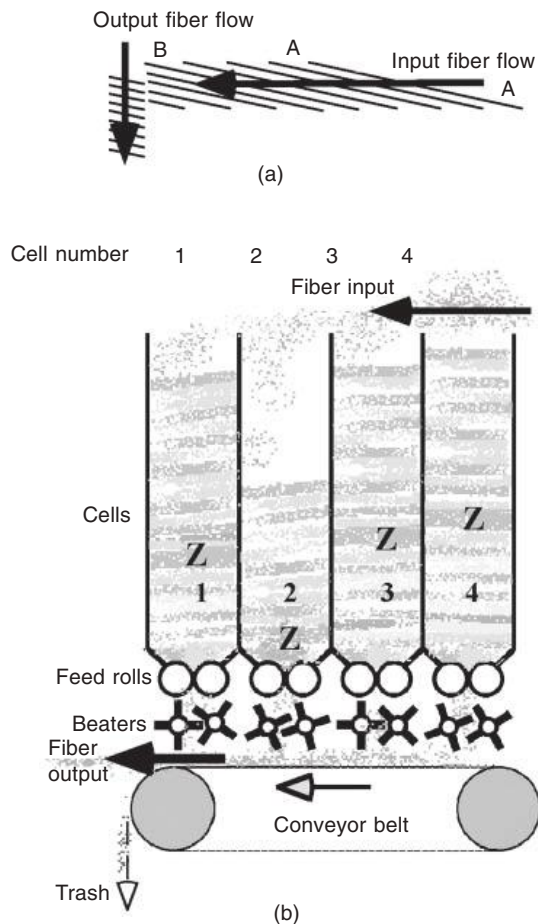

Fig. 5.7 Blending machine

The fibers flow to B where they are removed perpendicularly to the flow line across the many layers accumulated. This provides a means of ensuring reasonable homogeneity in the fiber blend over a certain mass of fiber within the output. If there are variations, which are very long, they overwhelm the blender and it can only ‘smear’ the boundaries of the changes. Such a situation certainly can occur when introducing a new type or merge of fiber. Some blending machines do not work as effectively as the one just described. In a common type, a series of cells is filled from the top to produce roughly horizontal strata that are often about 0.5 inch (≈ 12.7 mm) thick. Pairs of feed rolls empty the cells of stock and deliver the material to a conveyor belt below. The belt discharges the fiber clumps into an airstream that carries them to the next machine. If the strata remain roughly horizontal across all the cells and all the feed rolls were turned off and on at the same time, there would be little blending. In fact, the cells are not emptied uniformly and each cell should deliver fiber at different times. In Fig. 5.7(b), cell 2 is being emptied causing the strata of fibers within the cell to move relative to the others (NB the diagram shows a four-cell machine but larger numbers of cells are available). This causes blending by taking vertical slices as described earlier. The positions of the strata marked Z show the effect that is obtained.

The volume in a cell is limited and the amount of mixing is spread over a limited volume. Again, very long-term changes in blend may not be smoothed.

The question of recycling waste arises. Klein [3] quotes maximum percentages of recycled waste fibers as 5% for ring spinning; also between 5% and 20% for rotor spinning according to count. Hard waste (e.g. roving waste) is often returned to lower grade products after some disintegration process where the recycled intermediate product is reduced to more or less separate fibers. Some spinners recycle their waste through weighpan feeders to give an even flow of waste rather than baling the waste and reintroducing it into the bale laydown. This is effective in stabilizing the waste percentage in the fiber stream.

5.9 Fiber flow

5.9.1 Fiber flow control

The crudest of controls is a level switch regulating an earlier but neighboring machine in the line. When the fiber in the chute rises above the set point, the delivery from the prior machine is cut off until there is a demand for more fiber. More sophisticated versions might involve two-speed delivery rates to give a smoother control, but these are more expensive. Of course, there is always a need to cut off the inflow where choking is imminent. Continued supply with inadequate removal causes material to become packed in the ducts and/or machines. Such a disruptive event is a financial burden to clear because of the human effort needed and the idle time of the machine. Control of the fiber flow becomes an important matter if the yarn produced is to fall within proper tolerances of fiber composition and linear density. One form of control uses an electric eye, mechanical feeler or some other device to measure the height of fiber within a confined space. When the height exceeds the set value it restricts, stops or diverts the fiber supply until the offtake has reduced the fiber to a slightly lower level as shown in Fig. 5.8(a). Machine 2 is controlling Machine 1, because Machine 1 is supplying fiber to it. Failure to stop or slow the flow when the hopper or chute of Machine 1 is too full would lead to a blockage in its entry port or the ductwork. Since several machines are used in series, similar controls can act to stop or slow the feed of fiber from the machines elsewhere in the chain. Machines 1 and 2 are drawn as cleaning machines but they could have been some other devices in the line. Some machines incorporate an overflow system. If there is an excess of fiber, the excess is diverted and recirculated to the feed. As was mentioned earlier, this is a rough form of evenness control but it also acts to prevent choking. This latter is important because if the machine has to be stopped to remove the choke in the feed, much of the production is lost during that time. Usually, there are only a few opening lines and therefore the economic repercussions of a shutdown can be quite severe.

Modern systems use chute feed systems to supply fiber to a card. The chute contains some device to measure the height of fiber in the chute and a means of controlling the packing density of the fibers in the column. Vibrating front plates, the flow of air and careful geometric design are elements often employed to maintain the packing density. Once that is maintained, a simple volumetric control of the fiber feed suffices.

It becomes necessary to insert automatic control to regulate the final yarn count on a bobbin to bobbin basis. It will be remembered that errors in the sliver produce long-term errors at spinning. Full bobbins are often randomly mixed with the

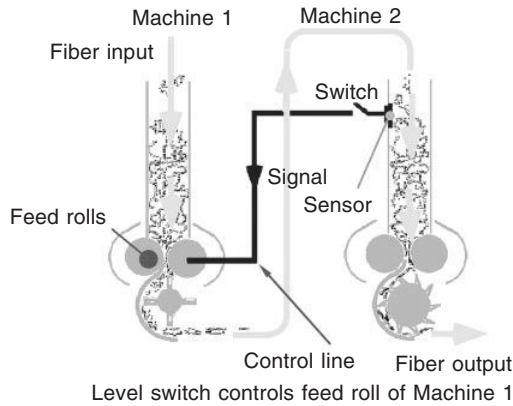

(a)

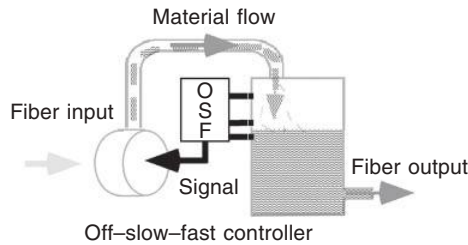

(b)

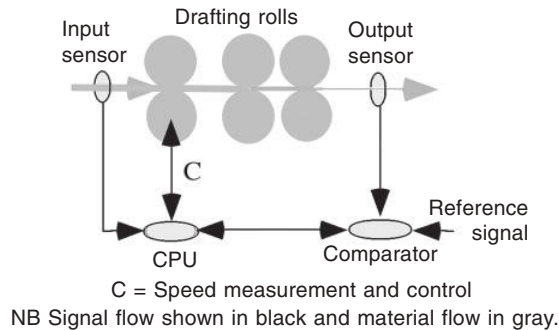

(c)

Fig. 5.8 Control systems and chute feed

result that material from bobbins of ‘thin’ yarn might appear next to material from bobbins of ‘thick’ yarns in the fabric.

Devices to control the level and densities of the fiber tufts are necessary to give good carding. The fiber level in the feed and fiber packing density of the fiber in both the reserve box and the main chute must be controlled within strict limits for successful operation. There are many forms of chute feed but space only permits the inclusion of one example (Fig. 5.8). This example has been chosen because it shows the need for careful control to ensure uniformity of mass flow in the supply of a fleece of uniform linear density and openness to the card.

5.9.2 Control and autoleveling

Simple controllers are found in the opening line, which are little more than on/off switches. They stop the feed when the textile material in a receiver in the flow line (such as a chute) reaches the set point. The set point is the desired level; the user normally adjusts it for the given conditions. If the material level reaches the *off* position in the receiver, it shuts off the supply and when it drops to the *on* position it starts up the supply again. It has to be remembered that each control has a lag time; shut off and restart does not cause immediate cessation or restart of the material flow. These lags produce error and if several such control systems are daisy chained, the cumulative lag can become quite large. The lags can lead to instability in the system unless it is properly designed and set. A slightly more sophisticated version has two supply speeds (S and F) as well as an emergency stop O (Fig. 5.8(b)). The slow feed is at a rate slightly below the normal feed rate and the fast feed is slightly above. The supply rate thus oscillates only within narrow limits around the mean level and the system can be more accurate and stable than the on/off version.

At the next level of sophistication, it is possible to measure the linear density of a strand delivered to a machine. An error signal from this measurement can then be used to offset errors in the supply system.

Devices like these are sometimes fitted in cards and drawframes; they are called autolevelers. The signal is an electrical voltage, air pressure or some other means of conveying information. If the measurement is made on the input and the output speed is changed, the device is a feed-forward device. The drawback to this method is that it takes no account of the changes it makes or of any changes in conditions. It has to work by dead reckoning. Thus if the calibration changes, or some other factor intervenes, an error is created. A typical means of controlling the linear density is to measure the output but control the input; this is called a feed-back system. A feed-back system has the consequence that the results of any change are carried by the material to the measuring device after a delay, but this can lead to instability. An example is where a transducer measures linear density of a card sliver as it emerges from the card, and the measurement is used to determine the feed roll speed. The change in draft alters the linear density of the sliver. If the variation is perfectly periodic, the system can be tuned to give excellent performance because the variations can be predicted on the basis of the history of measurement. In practice, random variations in linear density are present and an important component of the signal from the transducer is unpredictable. Some idea of how the problems arise can be obtained by considering a single thick spot in an otherwise flawless portion of sliver passing the transducer. The one-time increase in signal strength causes an increased draft for the duration of the passage of the thick spot through the measurement device. If the thick spot passes before the system can react, a thin spot is created in the following material. This thin spot later causes a negative signal and creates a thick spot and so on. Thus not only is there the original error but also echoes of it in following portions of the strand. Since an actual signal is a mixture of repetitive and random errors, a feed-back system can correct some components but not others. If the estimate of the time lag or the amplitude of correction is wrong, the strand will contain not just the random errors but some of the harmonic ones as well. It will contain the echoes just discussed. Thus feed-back systems have to be used with care.

A step toward further sophistication is to use both feed-back and feed-forward devices together in a combined system as shown for a roller drafting system in Fig. 5.8(c). The diagram shows only an input sensor but there are alternatives, which

cannot be further discussed. Roller drafting is sometimes used on sliver leaving a card before it enters a can and the draft is varied as part of the control system. A device compares the actual measurement of linear density with the desired one and passes an amplified value of the difference (i.e. the error signal) to the central processing unit (CPU). The computer unit uses algorithms designed to reduce the instabilities of the feed-back portion of the system.

It is normal to change the back roll speed in a drafting system in a card or drawframe. If the front roll speed is controlled, the speed of the can has to change also. However, the mechanical inertia of the coiler mechanism and the associated can full of sliver, resists sudden speed changes that might be called for by the control system. Such sudden changes produce heavy mechanical loadings on the coiler drive system. Consequently, the rate of change of speed of the output system with its high inertia has to be limited. This is done by smoothing the demand for change by limiting the rate of change of coiler speed. An alternative is to work with a temporary sliver storage system operating with a low draft roller system in series with the sliver take-off from the card.

5.9.3 Weighpan feeders

Some mechanical feeders use oscillating combs that remove excess fiber from the belt or lattice apron and give a measure of volumetric control of the fiber flow rate. This is a crude leveling device. More sophisticated feeders of this type are fitted with weighpan controllers that dump specified masses of fiber on to a conveyor belt as was sketched in Fig. 5.5. A number of such feeders are used to give close control of blend proportions; even though the technology is old, many are still in use today. Modern design favors continuous control rather than the intermittent supply inherent in the weighpan feeders.

5.10 Carding

5.10.1 The function of carding

Carding is where the last major stages of opening and cleaning occur. It is also where separated fibers are converted into the rope-like sliver form. The functions involved, like the other machines described, embrace opening (the division of fiber clumps), cleaning (even though this function is little used when making sliver from man-made fibers), blending, and condensation. There is, however, another function involved. This is fiber orientation. The card is the first stage where the fibers start to be straightened and get some orientation in a common direction. Thus the two following subsections will deal with fiber separation and the carding action. This latter action deals with fiber straightening, orientation, and a degree of condensation as well as the other functions. Following this, doffing (the removal of fiber from the cylinder) will be considered. Doffing entails a considerable condensation process as well as the conversion of the fibers from a sheet-like form to the rope-like one called a sliver. Cleaning will also be given a special subsection. Apart from removing short fiber and trash, the card also has the task of removing more nep than it creates. Other aspects of carding will also be considered.

In reading the following it should be appreciated that the speeds are high for such a large cylinder (therefore care has to be taken to keep the cylinder true and balanced).

Also, the surface speed is high and the teeth tend to pump a considerable amount of air and it is important to keep the moving surface covered, where possible, to prevent disruptive turbulent air currents from forming. Further, the surface has to be kept covered for safety reasons.

The design of the card developed in the nineteenth century. According to Gunter [4] there was little basic change over the next century except for the introduction of 'revolving flats' that move slowly over the surface of a rotating cylinder. The word 'revolving' does not mean that the flats revolve about their own axes but merely that they move around a specified path. The teeth on the active elements have to be very fine because they have to be capable of handling single fibers. The order of magnitude of a typical dimension is 0.1inch (≈ 2.5 mm). It also means that they are vulnerable to damage from foreign objects. This sets the tone for a discussion of cards. A sketch of a short-staple card is given in Fig. 5.9.

5.10.2 Fiber separation

The main feed roll advances a batt of cohering fibers and a thick fringe of these fibers is combed by the teeth of the licker-in as shown in Figures 5.9 and 5.10. This results

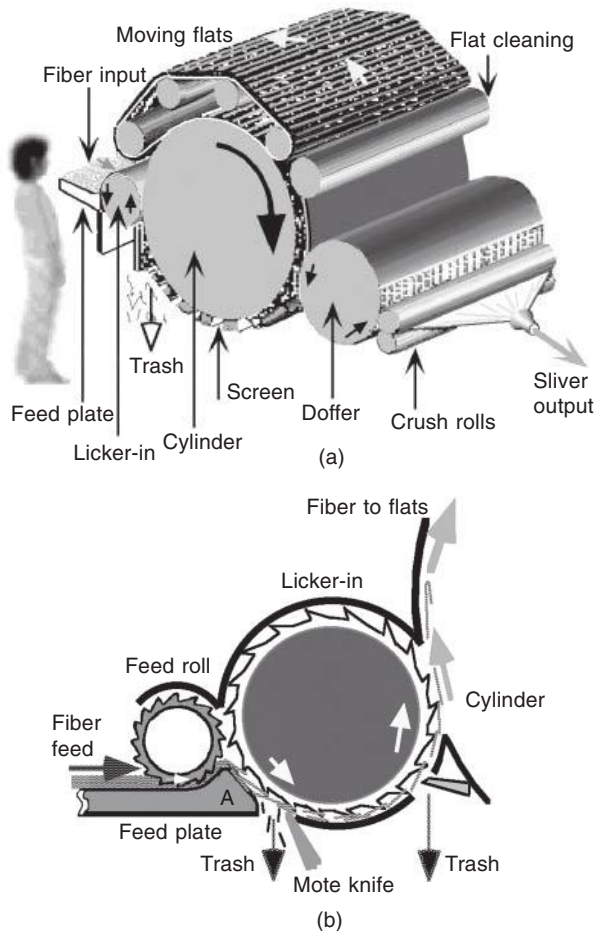

Fig. 5.9 Short-staple card

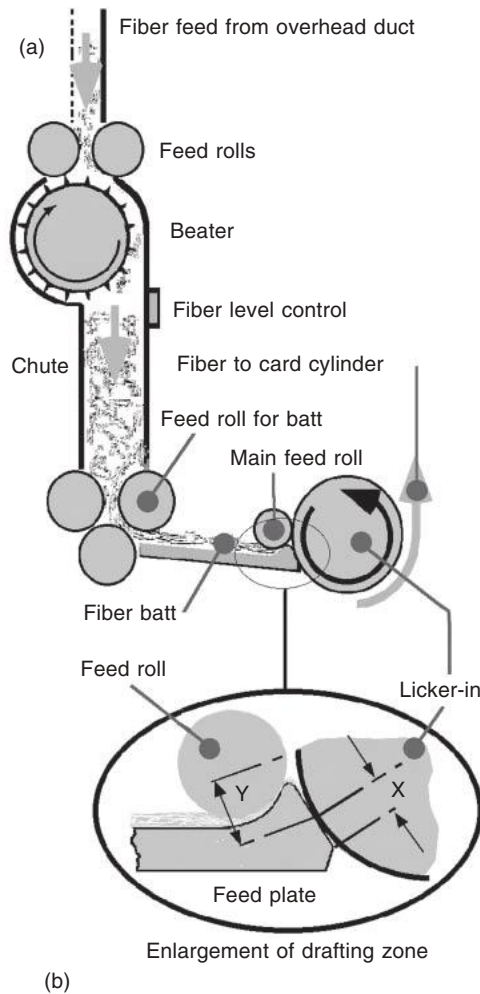

Fig. 5.10 Card feed

in a major separation and acceleration of the fibers, which implies a major overall drafting stage. Numerous further localized drafting episodes take place between the cylinder and the flats, which drafts clumps or tufts of fiber and reduces many of them to individual fibers before the process is complete. (Many dictionaries define a tuft as being anchored at one end but some textile authorities regard a tuft as a small aggregation of fibers. In this context, the aggregation of fibers is anchored temporarily in the card clothing and it might be felt that it is a more appropriate word to use in carding than 'clump'.)

As mentioned, the processes of drafting in a card cause some fiber orientation. Some of this orientation is retained because of the restraints provided by the proximity of the elements carrying out the process. The orientation is far from perfect but fibers within the tufts are no longer disposed in random fashion.

Considering this opening function, assume that the clump entering carding machines is 0.1 lb in size (approximately 10^7 fibers). Let these clumps each be first divided into 0.05 lb portions. Next, let the 0.05 lb portions be divided into 0.025 lb tufts and so on. There would have to be 24 stages of division ($2^{24} = 16.8$ million) before the tuft

would be reduced to single fibers. This is a theoretical case and it is much more likely that there would be large and small portions at each division. The total number of stages of division would then be dependent on reducing the large portions. Assume that, on average, each tuft is divided into 4/5 and 1/5. It would now take more than 73 stages of division ($(5/4)^{73} = 11.8$ million) to reduce it all to single fibers. The point of these very approximate calculations is to show the necessity of many stages of division and redivision. (Note: 0.1 lb \approx 45 g, 0.05 lb \approx 22 g, 0.025 lb \approx 11 g.)

Attention is drawn to the multitude of flats on the top of the machine. As mentioned, the licker-in removes relatively small tufts of fiber from the ingoing fiber batt, partially cleans them (if necessary), and delivers them to the main cylinder which carries them to the first flat. Many of the clumps or tufts are caught by the wire on the flat and a shearing action causes tufts to be torn apart. (The term 'wire' is used to describe the teeth on cards and some opening devices.) Most of the fibers initially caught by the flat are returned to the cylinder. Many of the divided tufts and the remaining undivided tufts are then temporarily caught by a second flat and are torn into smaller tufts. The process continues in this fashion until the fibers are almost completely separated and lie as a web on the surface of the main cylinder as it leaves contact with the last flat. Some 40 flats are needed in the carding zone to obtain the desired fiber separation and comparison may be made to the earlier calculations. Non-moving carding segments may be interposed between the licker-in, flats, and doffer to give a greater carding action. The segments carry fixed wire and are placed close to the moving cylinder wire; an action occurs there that is similar to that between the flats and the cylinder.

5.10.3 The carding action

Two alternative arrangements of the carding elements exist; in one, moving flats cooperate with the cylinder and in the other, fixed plates or segments are used. In the first case, some 40 flats are linked together and move slowly over an arc of the rotating cylinder. The surface speed of the cylinder is usually in the range of 500 yd/min (\approx 457 m/min). There is a small clearance between the teeth, the setting of which can be varied from 0.008 to 0.02 inches (\approx 0.2 to 0.5 mm) according to the fiber being processed. Thus the shear rate is very high and a tuft of fibers caught by one set of teeth is wrenched apart by the opposing set. There is very little time for the fragments of the tuft to relax until the next division is applied to them. Consequently the fibers within the tuftlets retain some orientation in the direction of shear, i.e. in the direction of movement of the surface of the cylinder. This permits a carding action. Portions of such systems of flats are shown in Fig. 5.11(a).

It is possible to replace the flats and their cleaning apparatus by a simple curved plate with fixed teeth (or even with a roughened surface) when carding clean fibers of relatively even length. Some designs exist in which trash can be evacuated from between the segments by interposing small wedge shaped plates that deflect the flow of air (Fig. 5.11(b)). The distances between the tips of the teeth on the fixed tops and tips of the teeth on the cylinder (i.e. settings) have to be carefully adjusted. Also care has to be taken with trash evacuation systems to ensure that they do not choke. Such chokes might not be detected immediately but cause deterioration in quality that might not be diagnosed in the early stages.

Worn teeth (Figures 5.12 and 5.13) give trouble and it is customary to test the card output for nep on a regular basis to provide a control. When the nep levels exceed a level determined by experience, grinding or rewiring become necessary. Excessive

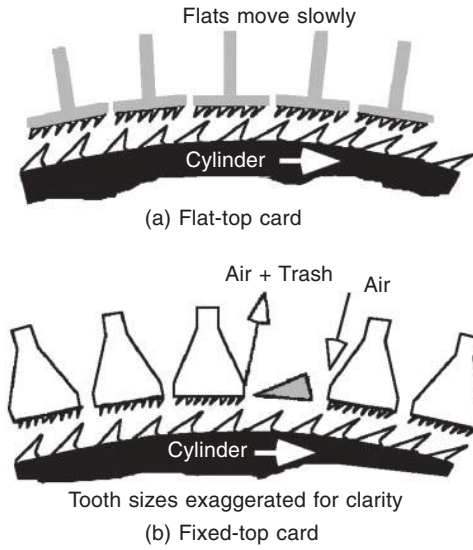

Fig. 5.11 Some card flat arrangements

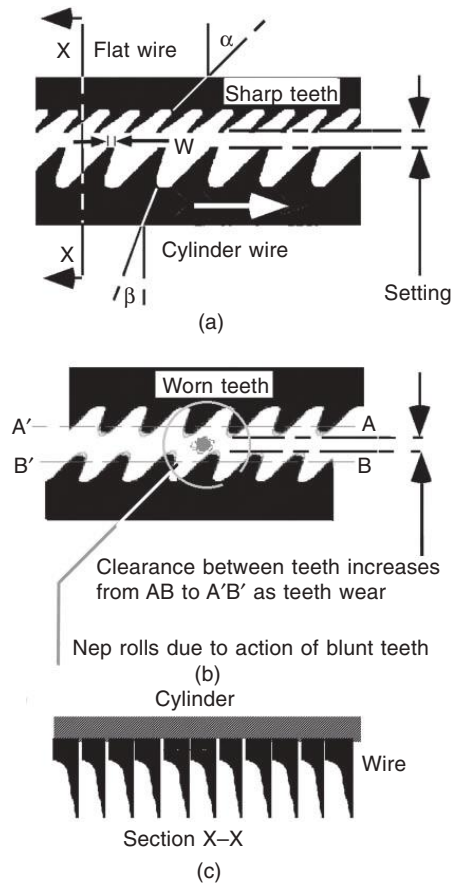

Fig. 5.12 Card wire and wear therein

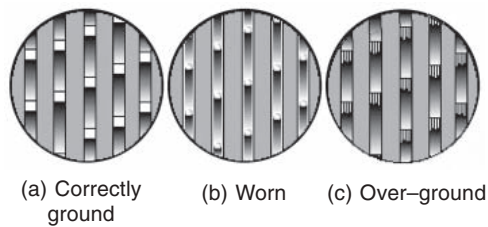

Fig. 5.13 Microscopic views of card wire

wear as shown in Fig. 5.12(b) would require regrinding to remove the metal between AA' and BB' before an adequately sharp edge could be attained. (Of course, the clearance would be restored to AB but the tips become wider.) The teeth are case hardened and consequently there is only a limited number of regrinds that can be carried out under normal conditions before rewiring becomes necessary. Case hardening means that the body metal has a thin skin of harder metal. For the extreme case portrayed, it would then be likely that the case hardening had been ground away, in which case there would be very rapid wear when the wire was put in to service again. Also it would be questionable whether a sufficient degree of fiber penetration could be achieved with the wide tooth tips. In regrinding, too heavy a cut with the *in situ* apparatus used to grind the tips of the wire causes burrs to form (see Fig. 5.13(c) for a view as seen with a pocket microscope). This condition might give good nep performance at the start but the performance deteriorates rapidly thereafter. If problems persist, it might be time to investigate other designs of card wire.

The fibers leaving the flats on the surface of the cylinder are sometimes exposed to another carding and/or cleaning process. Carding segments somewhat similar to, but larger than, the flats carry out the carding at this stage and further cleaning may be carried out by installing a knife edge with proper air pressure control and waste removal facilities. A cleaning edge is an effective way of removing pepper trash but care has to be taken to monitor the condition of the knife edge. Hard particles and abrasive material tend to nick and wear the vulnerable edge that then creates nep and causes operational problems.

Merényi [5] reported the sensitivity of the plate-to-cylinder and flat-to-cylinder settings. With a 0.008 inch flat setting the mass of flat strip removed increased by 150% as the plate setting was changed from 0.017 to 0.019 inch. The work was probably carried out with wire¹ clothing but it still has some relevance. (Note: 0.008 in \approx 0.2 mm, 0.017 in \approx 0.43 mm, 0.019 in \approx 0.46 mm.)

The reason can be imagined when it is realized that the ingoing nip of two large cylinders rotating in proximity creates a considerable pressure especially along the line A–A in Fig. 5.14. Unless the pressure is controlled and contained, it tends to blow out in the direction of the gray arrows and carry dust and lint with it. There is low pressure under the cylinder/doffer nip and the flow of air from the high to the low pressure zone affects the fiber orientation in the fiber transfer zone. The air pressure gradient in this zone affects air leakage as well as the fiber transfer between the cylinder and doffer.

¹ Modern use of the term 'wire' refers to saw-like teeth but originates from the use of wire embedded in a material fixed on the surface of the cards used in the nineteenth and the first half of the twentieth centuries. In this particular case, wire refers to the original meaning.

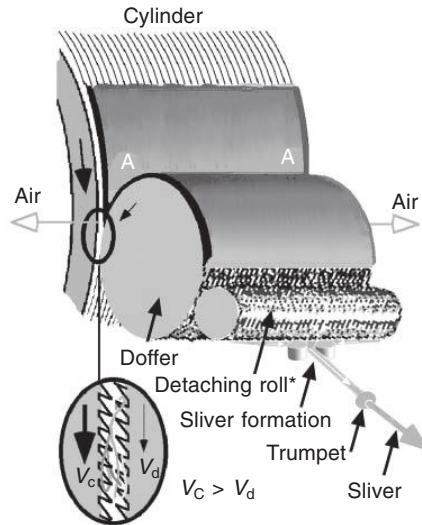

Enlargement of fiber transfer zone

*The toothed detaching roll shown is one of several alternative means of removing fiber from the doffer.

Fig. 5.14 Cylinder doffing

Not all fibers are removed by the doffer and many of them recirculate. Grosberg and Iype [6] carried out an experiment in which the doffer speed was varied sinusoidally and it was found that the amount of recirculated fiber varied similarly provided that the frequency of oscillation was not greater than about 1 per second. This was not a recipe for a practical operation but a means to determine how much the fiber recirculates and how much is taken off by the doffer. The work showed that there is a mechanism of fiber storage on the cylinder that might have importance in blending and doubling within the system. In other words there is condensation on the cylinder caused by the numerous layers of fiber being collected there.

5.10.4 Doffing

Modern cards remove the web from the doffer by a so-called wire-covered detaching roll of small diameter followed by a pair of smooth control rolls. Sometimes crush rolls are used to crush seed coat fragments so that they can drop out of the fiber stream. The web is then gathered together and passes through a trumpet or condenser which converts the web of fibers from the doffer into a rope-like sliver. (Note: this sort of condenser is quite different from the ones that collect fibers and extract dust.) In modern machines, the fiber flow is assisted in the transfer by aprons that condense the web to an intermediate condition before passing through the trumpet and calender rolls. A sketch of the major parts of a doffer system, but with the belts removed for clarity, is shown in Fig. 5.14. Should the fiber take-off system be improperly adjusted, it is possible to produce cored slivers, which are dense or entangled in the central core. Such cored slivers are difficult to draft in ensuing operations.

Calender rolls press the fibers together to give the sliver added cohesion and then the sliver sometimes passes to a drafting system, which adjusts the linear density. (Automatic control of the linear density of the sliver output is common today.) The

sliver is coiled as it is put into a storage can and the device that does this is called a 'coiler'. The can is used to transport the sliver to the next operational stage.

Returning to the main cylinder and doffer, the teeth are so angled and the distances so adjusted that the main cylinder gives up the fiber easily and the doffer collects some of it. The condensation occurs in the fiber transfer zone (shown enlarged in the diagram). It might be noted that the faster cylinder speed tends to 'brush' the fibers on the doffer with the consequence that the sliver emerges with a predominance of trailing hooks.

In older cards, the web between the control rolls and the trumpet is in a free triangular shape with the fiber being withdrawn directly from the surface of the cylinder. The open web is helpful in judging the quality of the web. The web is removed from the doffer by a vibrating comb. Sometimes the web passes between a pair of crush rolls to break up seed and trash particles and the crush rolls might replace the detaching rolls. The crush rolls are set with their axes not quite parallel so that the inevitable deflection in the center of the crush rolls will cause the nip line to have almost constant pressure along their length. Crush rolls should not be used with pressure sufficient to damage the fiber and they should be avoided when processing sticky cotton. Newer cards use different means of removing the fiber from the doffer. Sometimes belts are used to carry the sliver to one side of the cylinder; sometimes the sliver is 'rolled' and sometimes other means are used, but the principles discussed here remain the same.

For a reasonable output per card, say 100 lb/hr, and a thin web of fibers on the main cylinder, it is necessary to have a high surface speed. A cylinder speed might be, say, 142 r/min or roughly 500 yd/min at the surface. If the sliver were delivered at 65 grains/yd, the sliver delivery speed would be 7.5 yd/min. The difference in speed illustrates how there is a condensation effect at the doffer. Even though the overall draft in a card is, say, 100, the draft at the licker-in might be 500 with the speed of the fiber stream varying accordingly. The data are given merely to give an idea of scale. (Note: 100 lb/hr \approx 45 kg/hr, 37 yd/min \approx 33 m/min, 500 yd/min \approx 457 m/min, 65 grains/yd \approx 4.6 g/m or 4.6 ktex.)

The cylinder surface speed is higher than the corresponding speed of the doffer. This speed difference means that the web is condensed on the surface of the doffer and the web is usually several times as thick as it was on the main cylinder. Also, it has to be converted from a thin sheet to the required rope-like configuration. The normal way to do this is to remove the web from the main cylinder by a doffer whose surface speed is less than that of the cylinder (see Fig. 5.14).

5.10.5 Fiber cleaning in carding

Since man-made fibers need little cleaning and the major short-staple fiber is cotton, this section is devoted to the cleaning of cotton in carding. Although the cotton gin is designed to remove seed hulls, some debris from broken hulls is inevitably caught in the fibers entering the mill. The seed particles are woody and have seed hairs attached. Sometimes there are waxy, oily or sticky materials present. In seasons of insect infestations, cotton can contain sugar and insect excreta, which are sticky. Such stickiness makes carding difficult and it certainly adversely affects doffing. Very bad infestations can shut down a mill if there is not a sufficient diversity of sources of cotton in the mix supplied in the laydown. The only reliable solution to this problem is to avoid the sticky cotton.

The fibers are not completely separated from the woody material in the cleaning machines, nor are they in the carding process [7] as can be seen in the left-hand picture in Fig. 5.15. (For that matter, even drawing does not completely remove the trash particles as shown in the right-hand picture). Further, fibers still attached to a seed particle at this point are more liable to nep once the particle is removed. It can perhaps be realized how difficult it is to clean cotton in the process; it is not just a matter of shaking out the dirt.

Cleaning functions occur in three major zones in the card when carding cotton or other natural fibers. The first is in the region of the licker-in, the second is in the region of contact between the flats and the cylinder, and the last is under the card. We take these in turn.

Any fibers or trash combed out from the main fiber supply are carried under the licker-in over grids or other trash separating devices to the fiber transfer zone. This zone is at the nip of the licker-in and main cylinder (not shown). According to Gunter [4], the distance X in the enlargement of the drafting zone in Fig. 5.10(b) should be no less than 0.5 inch. This is because if it were much larger, the trash and tufts of fiber would become too deeply embedded in the wire. He also says that if Y is too large, plucking will occur and fiber clumps will be fed to the cylinder. Presumably this is really a reference to the nip to nip distance, which would be analogous to the ratch setting in a roller drafting system. Certainly the result is the same. After leaving the licker-in, the fibers are carried by the cylinder wire to the zone of the flats. Varga [8] quotes research from the Shirley Institute that established that the best performing diameters of the main elements of a card were 10 in, 40 in, and 20 in for the licker-in, cylinder, and doffer respectively. (Note: 0.5 in \approx 13 mm, 10 in \approx 0.25 m, 40 in \approx 1 m, 20 in \approx 0.5 m.)

The flats that have just been removed from the carding zone are brushed clean and are later returned to service at the front (or back) of the card. Material removed from the flats is called 'flat strip'. Forward moving flats are the most common; in this case the cylinder motion helps drive the flats and the removal of waste is easier. Where rearward moving flats are used, they meet the fiber in a clean condition at the front of the card but they accumulate short fiber and dirt as they continue to the back for cleaning. The dirty flats are not brought into contact with the cleanest fibers. The wire on the flats retains sufficient amounts of short fiber to clog them (i.e. load) fairly quickly unless the fibrous material is removed. Thus it is common to brush the flats continuously to clean them.

Not all the fiber on the cylinder is removed by the doffer; a fairly thick film of fiber is carried under the card back to the licker-in. It is normal to place screens, grids, and other cleaning devices under the card between the doffer and the licker-in to help control the airflow around the cylinder and contribute to the overall cleaning

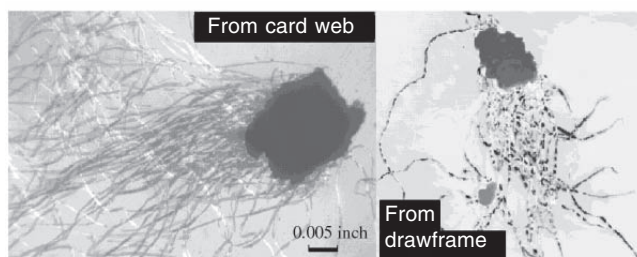

Fig. 5.15 Trash in card web and drawframe sliver

of the fiber. This cleaning would not occur unless some fibers recirculated on the cylinder. Care has to be taken to avoid the droppings from being sucked up back on to the cylinder surface. For that reason the doors to the under-card space must be kept closed. The trash that drops out here is often intermittently and automatically purged by a suction system. A poorly designed or defective purging system might agitate the trash under the card to the extent that every time it activates, it causes trash to be sucked back on the cylinder surface. This can cause periodic episodes of trashy sliver to be produced. Consequently it is useful to inspect the underside of the cards during a purge to see if there is any malfunction.

5.10.6 Card wire

So-called 'card clothing' is a continuous length of 'wire' containing teeth that is wound under tension on a plain cylinder and the ends are secured. A cross-section of the wire is L shaped with the upstanding portion containing the teeth. The base forms a foundation in contact with the cylinder (Fig. 5.12(c)) and sets the distance apart of the teeth across the width of the cylinder. The bottom of the L shape of the wire rests on the periphery of the cylinder. Careful heat treatment is needed during manufacture of the wire because the tips of the teeth have to be hard enough to withstand wear (≈ 1000 Vickers). However, such heat treatment makes the metal brittle and the main body of the tooth must retain its toughness; therefore the body of the tooth is tempered (≈ 200 Vickers). Skilled use of a flame is required to give the right distribution of temperature during the hardening process. The hardened tip of the tooth is only about 1 mm thick even when new, so there is only the possibility of a limited number of regrinds.

The shape and size of the teeth are altered for different fibers and frequently different pitches of wire are used on the cylinder and flats. The wire for the licker-in is always of a coarser pitch than either of them. The wire of the flats is easier to access and clean and therefore finer wire pitches are often used. Too fine a pitch causes the wire to 'load' (i.e. become jammed with fiber). Usually, the spacing of the wire is described in points per sq inch or sq cm. An aggressive wire is illustrated in Fig. 5.12(a), which would penetrate the masses of fiber and grip them well, but it might cause fiber breakage with some fibers. Even more aggressive designs use serrated wire and large values of α or β . Point populations vary from 250/inch² ($\approx 39/\text{cm}^2$) for coarse, long synthetic fibers to 1000/inch² ($\approx 155/\text{cm}^2$) for long fine cottons. Less aggressive designs have smaller attack angles α or β and non-serrated wire; these are gentler but not so effective in opening the fiber masses. The general comments apply to the wire on all surfaces, but the values differ. There is a whole range of designs according to the fiber being processed and the degree of initial preparation. To make informed choices, the mill manager should consult the wire makers.

As stated before, the clearance between co-operating sets of wire (i.e. the setting) is also important, as is the point population. A lower point population gives better penetration of the fiber mass and better opening, but such wire is incapable of separating the fiber as well as wire with higher point populations. When the wire is reground, the tips of the teeth are removed to get to a new sharp edge. In so doing the width W of the tooth ends increases as shown in Fig. 5.12(a); after several regrinds, the tip cannot achieve good fiber penetration and the card has to be rewired. New wire has a tip that is almost completely pointed. Allowing heavy wear is undesirable; reasonably frequent regrinding should be scheduled. The actual period depends on the fiber and the

requirements for freedom from nep. Maintenance of the wire condition is of great importance to the performance of the whole mill; it is not a matter to be taken lightly.

The choice of wire is an art and experience is very important. Mechanical loading of the teeth is caused by the carding action and this creates a problem with highly angled wire. The forces generated tend to bend the tips outwards and to reduce the distances between the tips of the cylinder wire and those of the flats. A reduction in clearance of this sort increases the loading and intensifies the problem. The tips have been known to touch and destroy the whole clothing at a cost of \$1000s per machine affected. Wire makers are very careful to avoid these problems but there are constraints in the design of the wire. Users should always remember that the danger of accidents of this sort increases as the settings decrease. Close settings are sometimes used to decrease the incidence of nep. However, the use of close settings should be closely monitored to check on their stability. The settings between teeth (typical values are given in Table 5.3) are measured by feeler gages and sometimes the flats are set to be slightly tilted so that the entering cylinder teeth meet the widest setting. Consequently care has to be taken to measure the settings in the correct places.

5.10.7 Airflow within the card

An aspect of airflow relates to the involuntary flow found within machines. When two parallel cylinders rotate in proximity, pressure differences are generated on both sides of the nip. If the rotational directions are opposite, as with a doffer and cylinder, an increased pressure is generated at the ingoing nip and a decreased pressure at the outgoing nip.

Pressure differences of this sort create an airflow particularly when the surface velocities are high and the surfaces are rough. An example can be cited with a card. Lauber and Wulforth [9] showed that an upward airflow existed which was directed upwards towards the 'nip' between the cylinder and doffer. The magnitude of the flow was about the same as the surface speed of the doffer. Other tests confirmed this and established, at least for the cases tested, that the airflow swept droppings from the doffer towards the nip. The use of proper covers and enclosures permits control of the flows of air that otherwise would create defects in the product.

The size of the apertures formed by the teeth in the nip and the degree to which they are loaded with fiber affects the airflow between the high and low pressure zones. In the case just discussed, the flow is vertically downward through the gaps between rows of wire. It is suggested that this airflow is a significant factor in the transfer of fiber from cylinder to doffer. On the entry side of the nip there is a tendency to expel fibers parallel to the axis instead of letting them continue unhindered in the tangential direction. Some fibers remain on the cylinder after passing the doffer. Considerations of conservation of mass flow dictate the mass of fiber to be transferred but do not control the fiber population on the wire. If the population is high, it takes significant time for conditions to equilibrate after starting.

Table 5.3 Some typical settings for a cotton card

Position →	Licker-in- cylinder	Flat-cylinder back	Flat-cylinder middle	Flat-cylinder front	Cylinder-doffer
	0.007	0.022	0.008	0.017	0.005 inches
	0.010	0.024	0.009	0.034	0.010 inches

5.10.8 Nep control

All fine fibers reaching the card have some percentage of nep, and, of course, this has to be minimized. The settings of the card are very important in this respect. Too wide a setting between the cylinder and flats will fail to remove as much nep as normal and will favor the creation of nep. Too close a setting (say 0.008 in) can lead to the problem of wire damage. Also wear on the wire widens the settings. Problems with bearings or 'bends' can increase the setting needed to avoid the wires touching. (Bends are guides on which the moving flats slide.) Normal settings are made by inserting a feeler gage of the right thickness into the gap and feeling the drag between the metal of the feeler and the wire tips. If the drag is heavy, the gap has to be widened and if it is too light, the gap has to be closed. Setting is a skilled art and even professionals vary in the actual settings they produce. Checks are often not performed until trouble is experienced. One machinery maker offers an electronic device for testing the setting while the machine is running. Several transducers are fitted on a rigid strip that replaces one moving flat. Electrical eddy currents give a signal that indicates the magnitude of the setting distance and this permits a frequent check of the settings without shutting down the card. Other settings are made with feeler gages and doubtless technologies will become available for continuously monitoring these too. As productivities rise and the use of fine fibers increases, the demand for proper control will rise. New technologies will be required to make it feasible to work in a region where very close settings indeed are required. The closer the setting that becomes practical and the more automatic the adjustment, the better will be the nep performance of the card.

The condition of the bearings and deflections of the machine parts govern the minimum setting. The fiber diameter and the loading determine the maximum setting. If the setting is much larger than one fiber diameter, there is a tendency for the fiber(s) to roll into a nep as shown earlier in Fig. 5.12(b). This is especially true if there is a nucleus already there or if the teeth are blunt. Nep is a cause of much concern, especially when spinning fine fibers. One prime site for nep creation is the zone between the flats and the cylinder. Also, damaged teeth in any of the card elements can create neps. Several major items have to be controlled; the wire must be sharp, without damage, and of the correct design for the job. A control chart of nep count should be maintained and the limits suitable for the market served should be established. A typical chart of the nep from a card is shown in Fig. 5.16 [10]. It will be seen how the nep count trend slowly rises (a regression equation is given for this portion of the curve). Further, it can be seen how the nep count drops after the card is reground and reclothed. Periodic examination of the condition of the wire with a pocket microscope is advised; this helps to catch any mechanical damage that has occurred.

The wire life is taken by some manufacturers of cards to expire after about 800 000 lb of fiber have been processed by the cylinder or doffer. The life of the licker-in wire is less and is quoted by the manufacturers to be about 200 000 lb. At 100 lb/hr, this is equivalent to running for 333 days for the cylinder and doffer or 83 days for the licker-in. Changes in fiber or mineral dust content alter these figures considerably; also the linear density and type of fiber are factors.

Continuous monitoring of nep count is a necessity in a modern mill. The card has to be taken out of service periodically and the time for this to occur is often judged on the deterioration of the nep count. The regression equation given in Fig. 5.16 applies to the period before reclothing. It implies a cylinder wire life of about 200

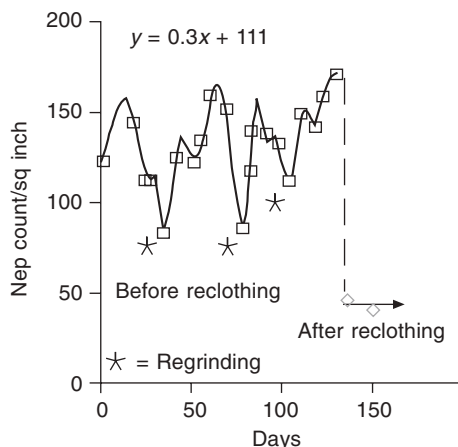

Fig. 5.16 Card wire life

days' continuous use (the graph is no more than a single sample of the normal deterioration of the wire; other cases can differ greatly). Reclothing refers to the mounting of new wire on the cylinder and other toothed elements. A wise operator does not rely solely on the machine maker's estimate but needs to check the performance of the particular machines directly. (Note: 800 000 lb \approx 363 000 kg, 200 000 lb \approx 91 000 kg, 100 lb/hr \approx 45 kg/hr.)

5.10.9 Air ducting

When a flow of fiber is distributed to a series of parallel branches, the distribution system requires approximately equal air velocities at all points in the ductwork. After an offtake from the system the volume of air flowing onward is reduced; the cross-sectional area of the duct has to be correspondingly reduced to maintain constant velocity. Changes in air speed create a danger of the heavier fractions of fiber being deposited in the early offtakes. Turbulence becomes more probable when an overlarge duct is used and while this is good for blending it can cause unwanted agglomeration of fiber clumps. As was mentioned earlier, rough edges in the ductwork cause strings of fiber to become entangled and, when they break free, they suffer fiber damage as they pass through subsequent machines. It is also associated with the generation of some nep in the system. Most systems work at pressures slightly below atmospheric to prevent the egress of dust and fiber. Leaks in the system waste energy because extra, unwanted volumes of air have to be pumped. Also a serious leak can reduce the flow in the upstream ducts and adversely affect the performance of the machines served by the starved ducts.

5.10.10 Sliver storage

Sliver is a soft, weak, rope-like strand that is easily damaged by stretching, crushing, or perturbation of the fiber order. Normal short-staple sliver is rarely wound externally on a package such as used for stronger strands (because of the danger of involuntary and uncontrolled drafting by stretching). Rather it is coiled into a sliver can in the fashion shown in Fig. 5.17 and this also facilitates easy withdrawal. The can is a large (usually) cylindrical vessel into which the sliver is fed for storage. The sliver is either:

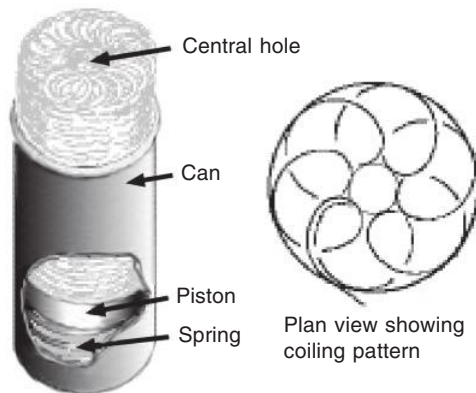

Fig. 5.17 Sliver can

(a) delivered through a rotating coiler head and is laid in a slowly rotating can or (b) fed through an epicyclic device to generate a sliver pattern without a rotating can.

There is an increasing tendency to use ever larger cans because this reduces handling costs. If it costs 10¢ to handle a can, then it costs 1¢/lb to handle a can containing 10 lb whereas it would only cost 0.2¢/lb if a can holding 50 lb were used. The reason for using large cans is self-evident but it also leads to space problems especially in the creel of a following machine.

The action of the coiler leaves a cylindrical hole down the center of the sliver in the can. Too large a hole reduces the storage capacity of the can. Too small a hole causes the sections of sliver around the periphery of the hole to be tightly packed, which produces false coiler patterns in the spectrograms of any such sliver tested. The coils of sliver must be laid with precision to optimize the mass stored and to prevent damage. To do this, it is necessary for the top layer of the material in the can to be near the coiler. This is achieved by using a spring-loaded false bottom to the can. The weight of the sliver depresses the so-called piston and the spring constant is so arranged that the level of the top layer remains at about the same level. A can with a bad spring or piston, or an overfilled can, causes the sliver to become crushed and the crushed portions are more difficult to draft than the rest. The cross-overs of the coil are regular and tend to be crushed most, so frequently a crushed sliver produces a periodic error in the material produced. The removal of a coil from a can puts in one turn of twist. The effect is scarcely noticeable with large cans but it does produce a slight effect with the very small cans sometimes used for open-end spinning.

5.11 Waste control

5.11.1 Waste generation

Operating machines produce waste products. These waste products may be classified as reworkable or non-reworkable. The latter are divided into subcategories of (a) non-lint materials removed during processing, (b) fiber unacceptable for the intended process, and (c) fly removed from the air conditioning or machines. The non-lint materials include trash, dust, and extraneous objects found in the fiber supply. The materials in categories (a) and (c) are usually disposed of as discussed later.

Klein [3] quotes the waste percentages for various fibers. The blow room losses range from 6% for 1 inch cotton, to 3% for 1.5 inch cotton (compared with approximately 15% and 10% respectively of total losses in a carded yarn plant). In buying cotton, the price includes the non-lint material and has to be considered in valuing the material. For a plant producing, say, 5000 tons/year, the losses due to unusable waste in the blow room can be as high as 300 tons/year. The quantity of recycled waste is higher than this. The value of the waste from a single mill might be measured in \$100 000s/year and the waste that has to be disposed of is measured in \$10 000s/year. Understandably, mills do not clean fibers more than necessary. At one time, it was thought that the use of an increased number of cleaning machines would improve the cleanliness of the cotton supplied to the card. It has since been found that, beyond a certain point, repetition of the same process was ineffective [1] and only induced unwanted fiber breakage. However, in the working range, the decision about the amount of cleaning must be the result of a compromise between costs, quality, and sales. (Note: 1 in \approx 25 mm, 1.5 in \approx 38 mm, 1 short ton as commonly used in the USA \approx 907 kg, 1 metric ton = 1000 kg.)

5.11.2 Waste separation

Cleaning machines are unable to remove the non-lint material without removing some usable fiber; at times the waste may contain up to 50% usable fiber. Neither are they able to remove all the non-lint material. Indeed, the removal rates vary from 40% to 70%, depending on the type of waste, the type of machine, and the running conditions.

5.11.3 Disposal of non-reworkable waste

Arrangements have to be made to deal with the waste produced. Returns from the spinning rooms such as pneumafil waste, remnants of sliver and roving, etc., are usually worked into the flow stream in such a manner to distribute it evenly in the fiber flow (Fig. 5.18). Pneumafil waste is fiber recovered from the drafting systems in the ring frames; the fibers are of good length but have been overworked and should be recycled sparingly. It is rare to exceed about 5% reworkable waste if good quality spinning is desired and some prefer to keep it down to 3%. Non-reworkable waste is sometimes sold for uses other than yarn manufacture; more often incineration, controlled dumping or some other form of authorized disposal is used. Klein [3] points out that the capital cost of the blow room is less than 10% of the total and a more serious financial concern is the cost of the waste. All the material that goes to waste has been paid for at the going price of the fiber concerned. To that must be added a portion of the running costs of the plant, the costs of baling or otherwise condensing the waste for transport, the transport itself, and the disposal costs. The waste costs are the sum of these costs less the resale income, if any. He points out that waste costs can amount to tens of thousands of dollars a year.

The air discharge from the fans contains dust, fiber debris, and particles that must be removed before the air can be returned to the atmosphere. Often a two-stage process is used in which cyclone filters separate the bulk of the waste and cloth filters carry out fine filtration. The latter are large and are usually installed in a 'dust house.' Sometimes parallel systems are used for processing different workroom air discharges. The size of filtration plant is of the order of 300 tons/year and the associated energy

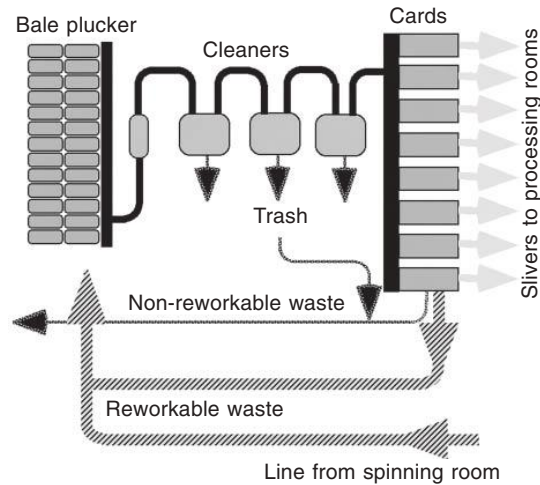

Fig. 5.18 Waste system

costs are significant. Since the air is expensively conditioned, it is normal to return the clean air to the operating rooms concerned, but an air wash is needed to remove remaining dust and rehumidify the air. The waste material from the dust house is compressed into bales or briquettes to facilitate handling. It may then be burnt. Briquettes are compacted to about 80 lb/cu ft ($\approx 1300 \text{ kg/m}^3$) and this is about the same density as a common house-building brick.

Modern day work regulations in many countries apply the rigor of law to ensure compliance. Thus waste is transferred and collected pneumatically; acceptable designs of fiber separation, waste baling, and dust house are required. Some fiber may be reworkable but not useful in the particular mill, in which case the fiber has to be separated from trash and perhaps de-dusted before resale. The waste is often baled for disposal; in which case, bale presses are needed. It is helpful to have a bale press for each type of waste, e.g. comb waste, licker-in droppings, flat waste etc., depending on the market or use for a given sort of waste.

5.11.4 Blending reworkable waste

Examples of reworkable waste are:

- 1 Short fiber (called noil) removed in the process of combing.
- 2 Spoiled product from the particular machine.
- 3 Waste from which usable fiber can be recovered.

Noil is clean and a saleable item (Section 6.3). Alternatively, it can be blended into laydowns to supply cards that make sliver for rotor spinning machines.

There are limitations to option (1). Yarns are difficult to recycle, roving less so and sliver is relatively easy to deal with. Roving has to be stripped from the bobbins before it can be recovered. Sliver of poor quality and the stripped roving just referred to may be reworked by making a bale of it, and then placing it in a subsequent bale laydown. However, care has to be taken to avoid dirty, oily or overprocessed material and only one or two bales of it should be inserted into any one bale laydown. Overprocessed fiber behaves poorly during processing and this is why the percentage of recycled material has to be limited.

Option (3) includes the reworkable waste from post-carding operations but excludes those mentioned under (2). All the reworkable waste has to be recycled with care. High percentages also give problems. If waste bales are near to one another in the bale laydown, a cyclic variation in waste percentage in the fiber stream is produced that might cause intermittent problems. When the fiber mix is too rich in waste fibers, production difficulties in subsequent processes are to be expected. By keeping an even flow of waste, the benefits of recycling can usually be garnered without undue trouble. Failure to control the waste flow can give most undesirable concentrations of poor fiber that can gravely affect the performance of the whole mill. Reworked fibers behave like short fiber because they have been overworked. Fiber crimp levels have been reduced, lubricants have been removed, and the surface of the fiber has been damaged, or perhaps broken. Such reworked material in excessive proportions in the main fiber stream produces drafting errors at every stage and causes increases in ends down. The result is that running efficiency drops, waste levels rise, and product quality further deteriorates. Also a portion of the recycled waste drops out during processing and this is associated with the amount of fly generated (which is often associated with badly performing mills). However, there is an economic benefit to recycling a small amount of fiber because the fiber costs are such a large percentage of the total for the yarn.

5.11.5 Card waste

Waste cannot be ignored in product flow calculations. For the moment, let us assume that the production efficiency without waste is 100%. If the system produces $x\%$ waste and the throughput without waste is P , the actual output is $P(1 - \{x/100\})$. If $y\%$ of the waste fiber is recycled, the regain is $\{xy/10^4\}$ and the feed of fiber is $P(1 - \{x/100\}) + \{xy/10^4\}$. In other words, the loss in production is $\{x/10^2 - xy/10^4\}P$. Naturally, the production P falls in proportion to the efficiency and the actual loss depends on how the plant reacts to the changes in fibers used.

A flat top card produces flat strips that are removed from the flats as they leave the proximity of the cylinder. These strips are accumulations of short, damaged, and usually unwanted fibers mixed with some good ones. Settings of the clearances between the cylinder and the co-operating surfaces are important. As the settings are reduced below the normal levels, the short fiber content of the fiber carried away by the flats increases. These wastes are often treated as non-reworkable. Fixed top cards produce no flat strips but do produce waste. Mote knives, gids, and/or screens under the cylinder allow waste to drop through, and there is also waste discharged from the licker-in. This non-reworkable waste probably contains cotton dust harmful to the worker; therefore it is now the practice to remove the material pneumatically by automatic means.

Fine trash is referred to as pepper trash. Many cards are now equipped with crush rolls which calender the emerging card web and crush particles of seed. Some of these particles are likely to be spiky or attached to fibers before the crushing operation. After crushing, a great deal of this unwanted material is then able to fall out instead of being carried forward by the product. It might be noted that there are powerful air currents generated by the card cylinder, doffer, and licker-in; these air currents can sometimes recirculate small trash particles and trap them in the material being delivered.

5.11.6 Effects of varying the opening and cleaning

If some of the opening machines are bypassed, the card licker-in waste increases and so does the flat strip. For example, private data showed that bypassing a cleaner in a production line gave 36% and 4.8% increases respectively; the yarn irregularity was increased by 1.7% CV and the strength decreased by about 7%. On the other hand, adding a machine can cause problems too. In another example, an added cleaning machine caused the licker-in waste to increase by 13.6% and flat waste by 2.5%. This was because of the fiber damage caused by excessive working. The yarn deteriorated too, with CV increasing by 1.6% and the strength decreasing by about 5%. Excessive opening and cleaning can do as much harm as having none at all. A careful balance is required.

5.12 Safety

5.12.1 General concepts

The machinery used in opening and carding can be very dangerous. Nearly all the machines use rotating beaters or surfaces with teeth or pins rotating at high speed. Great care has to be taken by the operators to avoid the dangers of being caught by the machinery or by the ingoing textile material. Neglect in this area can result in serious physical injury.

By law, machinery has to be provided with suitable guards to prevent the operator coming into contact with the dangerous parts of the machines while they are operating. Interlock switches are nearly always mandated by law and these are designed to stop the machine if a guard is removed.

The working environment is affected by discharges of particulate matter and noxious substances. The blow room is particularly vulnerable to discharges of dust into the atmosphere of the workplace and is, in most countries, subject to regulation.

5.12.2 Safety in the blow room

Historically, the blow room and the carding areas were dungeons of unimaginable filth. The machinery had many dangerous units with rotating beaters and sharp teeth moving in unguarded enclosures, leather belts flapped waiting to entrap the careless, large volumes of dust hung in the air with the result there were many accidents and many workers became sick. Things have improved very markedly since then but this is no reason for complacency. Modern machinery has eliminated much of the risk to the operators (it would be unwise to say that it has been eliminated). However, there is still much old machinery working in various parts of the world and it is useful to look at some of the out-of-the-ordinary risks.

A few of the dangers are:

- 1 Bales are handled by fork-lift trucks and rules applying to the control of vehicular traffic in restricted spaces have to be instituted and enforced if accidents are to be avoided.
- 2 The release of the straps from the bales has to be carried out under controlled conditions to avoid injury from the violent release of the straps when the coverings are removed.
- 3 The bale plucker is a ponderous machine and cannot be stopped in an instant; consequently control of personnel in the operating range of these robots is important.

- 4 Many of the machines are very tall and means have to be provided for safe access to the higher elevations of the machines and ductwork.

As was just mentioned, dust could be a problem; it certainly used to be in cotton mills and thousands of workers in cotton mills became ill with byssinosis. Machinery today is required by law to be fitted with means of suppressing dust emissions and the space in which they operate has to be adequately filtered.

Fortunately modern machinery is enclosed and a variety of safety locks and protective devices are installed so that the risk to the operators is greatly reduced. Older machinery requires more scrutiny, adjustment, and strict management to approach the safety levels required.

5.12.3 Safety in the card room

Most of the warnings relating to the blow room apply here as well. However, there are more machines that are often closely packed and certain additional warnings are in order.

The very high inertia of cards poses a particular hazard. It takes some minutes for the cylinder of a card to stop after the motor is switched off, even if a brake is applied. The normal interlocks are to little avail if a guard is removed and the operator then carries out a dangerous act while the cylinder is still rotating. All too many workers have lost fingers, hands, or even arms by disregarding the rules of safety. The most dangerous areas are the zones around the feed roll supplying the licker-in and the doffer. In the first case, never attempt to adjust the batt just entering the feed rolls because it is all too easy to get caught in the material as it enters the pinch of the feed roll. In another case, it has been the practice to scoop up the web emerging from the doffer take-off system and feed it into the sliver take-up device or merely to take a sample. The danger is in touching the doffer surface with its sharp teeth moving at a considerable speed.

References

1. Szaloki, Z S. *Opening, Cleaning and Picking*, Inst Text Tech, Charlottesville, VA, USA, 1976.
2. El Mogahzy, Y E. On-line Monitoring of Fiber Quality: Merits and Challenges, Private communication, Dec 1994.
3. Klein, W. *A Practical Guide to Opening and Carding*, Manual of Textile Technology, 2, Textile Institute, 1987.
4. Gunter, J K. *Carding Innovations*, Josef K Gunter, Durham, USA, 1994.
5. Merényi, G. *The Effect of Reduced Flat Speed on Cotton Carding*, Tech University, Budapest, 1957.
6. Grosberg, P and Iype, C. The Effect of Dynamic Changes in Doffer Speed on Cylinder Loading. *J Text Inst*, **82**, 4, p 457, 1991.
7. Criado, J J. *TX590 Project Report*, N C State Univ, Raleigh, 1977.
8. Varga, J M J. *Technical Innovations in Carding Machines*, Tomorrows Yarns, (Ed Hearle, J W S) UMIST Symposium, June 1984.
9. Lauber, M and Wulfhorst, B. *Non-contact Gauging of the Fiber Flow During Carding and Drafting Cotton by using LDA*, RWTH, Germany, 1995 Beltwide Cotton Conferences, National Cotton Council, Jan 1995.
10. Propst A. *AFIS In-plant Quality Control*, 7th Annual EFS Conference, 1994.