

# Appendix I

## Traditional Loom Mountings and Special Jacquards

Most of the shedding arrangements described in this appendix are no longer employed or are used only to a very limited extent. As has been explained in Chapter 1 they have been devised to improve either the comparatively small figuring capacity of coarse pitch jacquards or the laborious operations of the design painting and card cutting. In most cases the special systems were capable of working only at a slow and therefore, uncompetitive speed and with the advent of a new generation of fast jacquards with high figuring capacity and complete versatility they had to be discarded.

Apart from historical interest the special mountings represent a stage in the development of shedding motions which in its ingeniousness is also technologically interesting.

### HEALD AND HARNESS MOUNTINGS

Healds are used in association with jacquard harness to relieve the jacquard of the need to control such ends in compound structures which are required to weave in a closely defined repetitive order with a repeat length not exceeding eight to twelve picks. Their use results in both an increase in the figuring capacity of the jacquard and in the simplification of design painting and card cutting. In certain constructions it is still convenient to employ healds in conjunction with the jacquards as described with regard to leno and warp pile fabrics.

The number of healds used normally varies between one and four depending on the weave repeat of the ends which they control and the density of setting. They can be mounted either in front or at the back of the harness and their operation can be controlled by negative tappets, positive tappets, a dobbie or the jacquard itself by utilising the spare hooks.

The functions of a heald assembly can be classified under three broad headings:

- (1) To operate ground threads so that a simple and unchanging foundation structure be provided for the display of the figuring thread elements.
- (2) To operate auxiliary threads such as stitching, stuffing or wadding ends in a constant order; the former for the purpose of binding the figuring

weft to the ground structure or to stitch together cloth layers in multiply constructions, and the latter to retain the wadding material in the centre of the cloth.

- (3) To introduce binding weaves into cloths in which the jacquard only determines the areas in which warp float or weft float effects are produced.

### *Heald control of ground ends*

In modern practice healds are still used to operate the ground ends in the production of jacquard figured warp pile fabrics, as described in Chapters 15 and 16, and also in jacquard lenos, as shown in Chapter 12. In other constructions they are not normally employed due mainly to their restricting influence upon the structural versatility of the jacquard. At one time, however, their use was widespread and typical examples are given in *Figure A1.1*.

A in *Figure A1.1* shows a mounting with one heald suitable for warp rib brocades or figured repps (see Chapter 6) in which the odd ends weave continuously one tabby of the plain structure as indicated by the dots in the fully worked-out design B. Figure is developed by floating the even ends as desired which is represented by the diagonal marks at B. It will be noted that the jacquard controlled even ends are all raised on the odd picks to make the opposite tabby to that produced by the heald, therefore, in the simplified design at C it is necessary to indicate the lifts of the even ends on even picks only. The card cutter will then be given the design as at C with the following instructions: Cut all marks, lace-in fully perforated cards for odd picks. The cards cut according to the design are laced-in for even picks whilst the fully perforated cards, which will have been previously punched on a repeater machine, are introduced for the alternate picks as indicated by the arrows at C.

D in *Figure A1.1* represents a mounting suitable for extra warp figured fabrics (see Chapter 2) which was extensively used, particularly for the making of Alhambra quilts. The harness mails were frequently double so that two figuring ends were operated as one to achieve better cover. The two healds operate the odd ends in plain weave order producing a complete ground structure, represented by the dots in the fully worked-out design at E, whilst the jacquard-controlled even ends form the figure by floating on the plain ground where required. The simplified design, in which only the floats of the even ends need be indicated, is shown at F. The card-cutting instructions are simply: Cut marks.

As the healds in both mountings, A and D, complete their sequence of operation on two picks they can be conveniently controlled from a plain tappet assembly on the bottom shaft of the loom.

The mounting given at G in *Figure A1.1* is suitable for book muslin structures (see Chapter 5) and although two healds are shown both are controlled from the same tappet and operate as one. It will be seen by studying the interlacing diagram H and the corresponding fully worked-out design I that the structure is a stitched extra weft figured effect in which the extra picks are retained by selective lifts of the jacquard-controlled even ends. Where the extra weft is

not required it is permitted to float freely on the surface of the plain ground cloth the free floats being severed in finishing. The weft is inserted in a constant sequence of 2 ground, followed by 2 extra picks. The plain ground is formed by

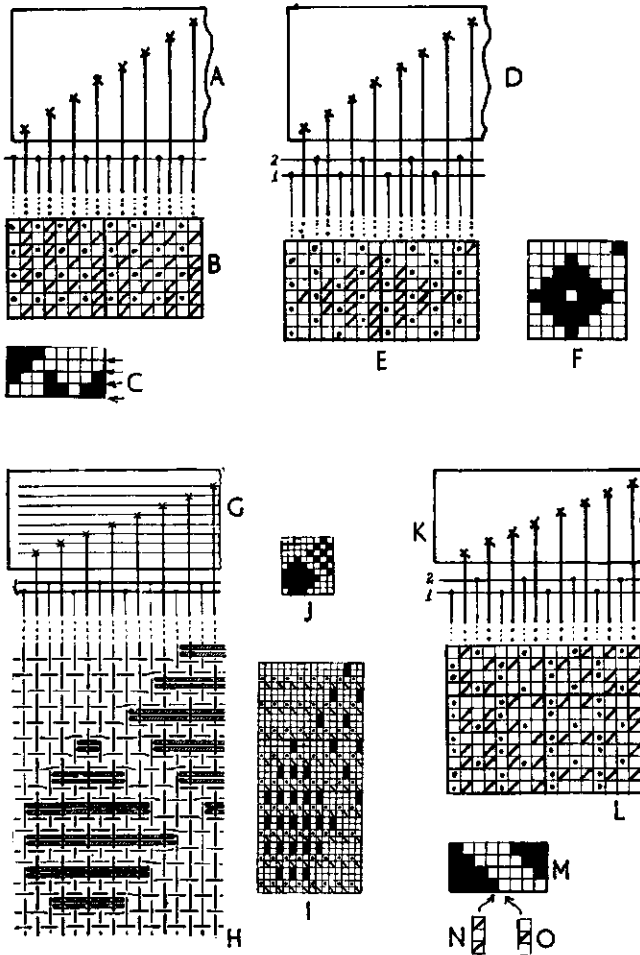


Figure A1.1

the alternate lifts of all the jacquard-controlled (even) ends on the first pick and all the heald-controlled (odd) ends on the second pick. The healds are tappet controlled and operate continuously 1 up, 3 down being up on the second pick of the 4-pick sequence as shown by the dots at I. On the first pick a fully perforated card causes a lift of all the jacquard-controlled ends, on the second pick the heald is raised and a blank card is introduced to keep the jacquard-operated ends down. Picks 3 and 4 are the extra picks on which the heald is down and the jacquard-controlled ends are raised selectively according to a simplified design given at J. Thus, the instructions can be formulated as follows: Cut two cards from each horizontal row of design (picks 3 and 4) cut marks; lace-in a fully perforated card for pick 1 and a blank-card for pick 2.

K in *Figure A1.1* shows a typical mounting used for figured terry pile fabrics (see Chapter 14). The pile alternates between the face and the back whilst the healds weave the terry ground structure, the first one operating 2 up, 1 down, and the second one 2 down, 1 up. The simplified design M is condensed by 3 weft-wise a filled square representing a pile loop on the face as given at N, and a blank square, a pile loop on the reverse side as given at O. To produce the full structure from the simplified design M the following cutting instructions must be formulated: Cut three cards from each horizontal row; first card—cut marks, second card—cut blanks, third card—cut marks. The same design could be used to produce 4-pick or 5-pick structures with suitably amended cutting instructions.

The healds in the mountings G and K were usually controlled from a negative tappet assembly mounted on a counter shaft with a suitable pinion to give a ratio of bottom shaft to counter shaft rotation of 2:1 in the former, and 3:2 in the latter case.

### Heald control of stitching ends

In modern jacquard weaving healds are not normally used to operate the stitching ends but other auxiliary yarn elements are still sometimes heald controlled. One example of this occurs in the weaving of figured warp pile fabrics where the stuffer yarns are operated by a heald as shown in Chapters 15 and 16. Heald control of the stitching yarns in association with coarse pitch jacquards resulted in both, the increase of figuring capacity and the simplification of design painting and card cutting exactly as in the case of heald control of the ground ends described previously.

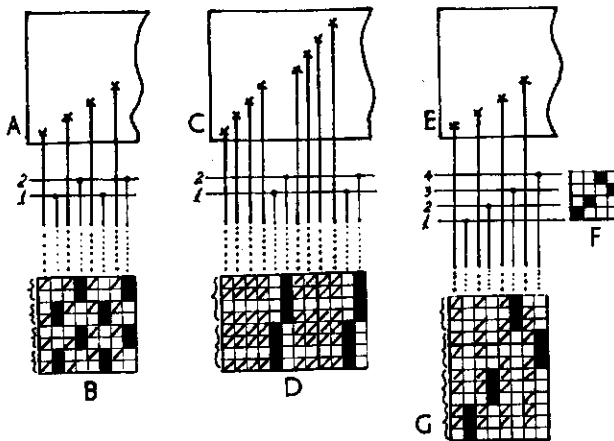


Figure A1.2

The stitching ends bind the weft yarns in a set order and the three examples given at A, C and E in *Figure A1.2* show arrangements suitable for weft tapestry structures (see Chapter 11). At A the ends are arranged 1 ground, 1 stitching, and two healds are used which operate alternately 2 up, 2 down binding the

figuring wefts in a regular order as shown in the fully worked-out weave B by the solid marks.

At C there are also two healds but, as the structure is a 4-weft tapestry, they are operated in 4 up, 4 down order. The arrangement of ends being 4 ground, 2 stitching, the binding ends tend to produce a vertically ribbed surface in the cloth. In the fully worked-out weave at D the lifts of the stitching ends are indicated by the solid marks.

In the example E four healds are employed, the stitching being carried out in a satinette order indicated at F. As the structure is a 3-weft tapestry the actual heald lifts are 3 up, 9 down, as shown clearly in the full weave at G. In view of the long weft-wise repeat of the stitching ends in some of the above structures the healds which control them are not operated by negative tappets. Sometimes positive tappets are used but frequently it is most convenient to employ a dobbie for this purpose as it permits of an easy change-over to suit different structures (2-weft, 3-weft or 4-weft tapestries) without the difficulty of changing complete tappet assemblies, drives, etc.

Other examples of the use of healds in the control of stitching ends are shown in subsequent sections of this appendix where healds are employed together with other shedding elements in more complex mountings.

#### *Insertion of binding weaves by healds*

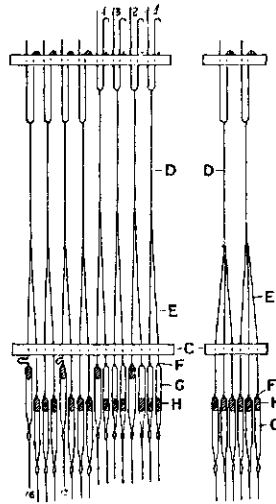
In hand-loom weaving of figured damasks a system known as the pressure harness was at one time used. In this mounting the jacquard and the healds controlled the same ends but whilst the jacquard mails controlled several ends at a time the healds controlled the ends singly. The jacquard cards merely determined where a warp float or a weft float area would be formed in a block type of selection. The healds were used to bind such areas structurally by introducing individual end lifts or drops usually in a satin and sateen order. As the dual control of ends resulted in the healds countermanding some jacquard selections double sheds were formed with the resultant excessive strain on the ends which were pulled one way by the jacquard and the other way by the healds. Some attempts were made in the late nineteenth century to adapt this system to power looms but as it was based on an unsound technological principle the efforts were unsuccessful and the system is now only of historical interest. When multiplication of pattern in damask weaving is required now, jacquards of the self-twilling type are used (see Chapter 6).

### THE BANNISTER HARNESS

The bannister harness (also known as the split or scale harness) was developed for weaving of fabrics which were very finely set in the warp in order to double, treble or quadruple the width of repeat. Non-reversible silk damasks are one example of structure for which this arrangement was frequently used.

In the most common form of split harness, illustrated in *Figure A1.3*, an ordinary single-lift jacquard is used, but some distance above the comber-board C each single cord D from the neck cords is connected to two or more double

harness cords E, each of which is passed through a separate hole in the comber-board. A knot F is tied in each double harness cord, so as to form, above the mail, a loop G which is sufficiently long to allow the proper depth of shed to be made. Also, the comber-board is placed high enough above the knots F to permit the cords to be lifted the proper height without obstruction. The diagram on the left of *Figure A1.3* represents an 8-row machine, in which the scale is doubled—i.e., two looped harness cords are connected to each single cord D, giving 16 rows of harness cords in the comber-board C. On the right of *Figure A1.3*, three looped harness cords are shown connected to each single cord, which in an 8-row machine, gives 24 rows in the comber-board.



*Figure A1.3*

A bannister shaft or rod H, which is rather longer than the width of the harness, is passed loosely through the loops of each long row of harness cords, so that each rod is capable of lifting one end in every sixteen or every twenty-four etc., according to the number of rods employed, quite independently of the figuring cards. The arrangement does not prevent the jacquard from lifting the ends in forming the desired figure, but they are necessarily raised by the hooks in groups of two or more to correspond with the scale of the harness. By lifting the rods, the ends that are left down by the jacquard may be raised singly and produce any ground weave (plain, twill, sateen, etc.), which repeats upon a number of ends that is a factor of the number of rods employed. Thus, in the diagram on the left of *Figure A1.3*, the hooks 1 to 4, which are shown raised by the jacquard, lift up the harness mails 1 to 8, but the rods are raised in 1-and-3 order, and lift up one-fourth of the mails—viz. the twelfth and sixteenth—which are left down by the jacquard. Only warp figures can be formed on the surface as the cloth is woven, and a weft figure is therefore produced by weaving the texture face side down.

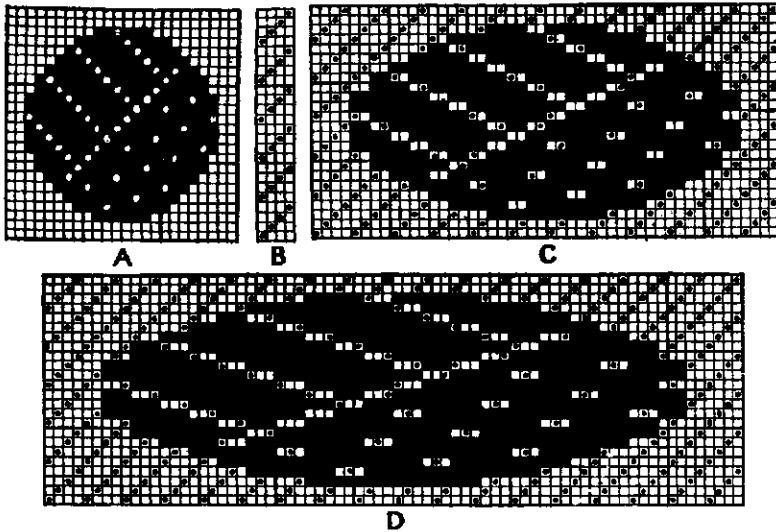
The rods H may be operated by means of a dobby, but it is generally convenient to use a number of hooks in the jacquards, cords from which are passed through guide holes in the comber-board to each end of the rods. If the card cylinder is at the back or front of the loom a row of special hooks should be

used at both sides of the figuring hooks, in order that the weight will be evenly distributed on the machine. In some cases the needles and hooks, by which the lifting of the rods is governed are situated a sufficient distance from the figuring needles and hooks to enable them to be operated by a separate small set of cards. This method has the advantage that a design may be woven in different ground weaves simply by changing the small cards.

The split mounting is sometimes arranged with two neck cords (which pass separately through a board) to each hook, and with the loops, through which the rods are passed, formed in the neck cords. It is claimed for the arrangement that the rods are situated where there is most space and are out of the way of the weaver. The double neck-cord system is also used in conjunction with a double-lift single-cylinder jacquard machine.

*System of Designing*

In painting out designs no ground weave requires to be filled in, as this is produced by the lifting of the rods, but the long floats of the figure require to be stopped in the usual manner. Thus, A in *Figure A1.4* illustrates the method of preparing a design for the card cutting, the instructions for which are: Cut marks. Assuming that the rods are raised in 1-and-3 twill order—as indicated at B—the full design will be as shown at C in double-scale mounting, and as represented at D in a treble-scale mounting. At the edge of the figure each step of one in A corresponds to a step of two ends in C, and three ends in D; while similarly, each single binding point in the figure represents two ends in C and three ends in D. In the ground however, the ends are operated singly, as shown by the dots.



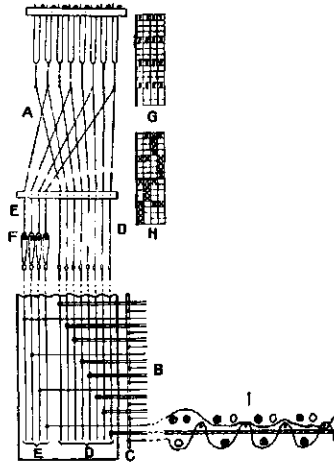
*Figure A1.4*

It is necessary to take into account that the lifts produced by the rods are liable to occur where ends have been left down by the jacquard for the purpose

of binding the figure. The dots inside the figure in B and C indicate such lifts, and it will be seen that the binding of a warp float is neutralised at each place. In fine cloths which have a weft figure upon a warp sateen ground (produced by weaving the cloths wrong side up), the defective warp float is on the wrong side, and the fault is considered of such little importance that it is generally ignored.

*Lifting rod and heald mounting for repp-stitched weft tapestries*

A special form of bannister mounting used in conjunction with a heald-and-harness system and suitable for repp-stitched weft tapestries (see Chapter 11) is shown in *Figure A1.5*. In this case the rods are used simply to enable the back-stitching harness to be operated independently of the figuring harness. The hooks and needles are arranged the same as in an ordinary machine and it will be seen that there are twenty ends in the cloth to each row of eight hooks and needles.



*Figure A1.5*

The cloth, which is a 3-weft tapestry, is woven wrong side up; the heald is left down on the figuring picks and raised on the binding picks, as shown at G in *Figure A1.5*, while the rods are raised by means of special hooks in the jacquard, in the order indicated at H. The rods are lifted one at a time on the figuring picks, and stitch the wefts that are not forming figure in a satinette order on the reverse side of the cloth. Three of the rods are always left down on the figuring picks, and it is to automatically prevent the ends controlled by them from interweaving with the weft that forms the pattern on the under surface (the right side), that the back-stitching harness cords are connected to the figuring harness cords. Where a weft forms the pattern on the right side of the cloth the figuring ends are raised, and with them the corresponding back-stitching ends, so that the latter do not interweave with the weft on the face side of the cloth. The back-stitching ends really form a loosely woven cloth with the weft on the reverse side, which, however, is stitched to the face texture by the interweaving of the back-stitching ends with the binding picks. This is effected by leaving one rod down on each binding pick, as shown by the blanks on the picks, 4, 8, 12 and 16 in the plan H, and also in the weft section I.



## SECTIONAL JACQUARD AND HARNESS ARRANGEMENTS

Sectional systems of mounting are used in the manufacture of cloths which are composed of two or more different kinds of warp threads—arranged alternately, or in 2-and-1 order, etc., with one another—each of which has a separate function in forming the design or the structure of the fabric. Except when employed in conjunction with a special harness mount (e.g., working comber-boards), the object of a sectional arrangement is solely to simplify the processes, and reduce the cost of design painting and of card cutting. There is no saving, as compared with an ordinary form of jacquard and harness, in either the number of hooks, or the number of cards required for a design.

The different kinds of warp threads must follow each other in the harness in the order in which they are required in the cloth; the sectional arrangement enables each kind of warp to be governed by a separate section of the needles, so that the lifts of each warp can be cut independently upon a corresponding section of the cards. Three methods of accomplishing the result are illustrated in *Figures A1.6* and *A1.7*.

*Sectional harness ties*

In the method shown in *Figure A1.6*, the hooks and needles are connected in the ordinary manner, but a special system of tying up the harness is employed. A separate transverse section of the hooks is allotted to each kind of warp, the number of hooks in the respective sections being in the same proportion as the threads of each kind. From each section of hooks the harness cords are passed through a separate *longitudinal* section of the comber-board to correspond, and each kind of warp is drawn through the harness mails of the section allotted to it. The hooks are divided into two equal parts, A and B, and the harness cords that are tied to the hooks A are passed through the front longitudinal section A of the comber-board, while those tied to the hooks B are passed through the back section B of the comber-board. In the warp draft, which is represented in the lower portion of *Figure A1.6*, the even ends are shown drawn through the harness mails of the front section A, and the odd ends through the mails of the back section B. One half of the needles, taken consecutively, thus governs the even ends, the lifts of which are cut on the corresponding half of each card, while the other half of the needles governs the odd ends, the lifts of which are similarly cut on the other half of each card. In weaving designs, which are so large that two machines placed side by side are required, one machine will govern one series of ends, and the other machine the other series; the two machines being operated as one. This is very convenient for the card cutting, as the provision of two separate sets of cards enables one warp to be cut quite independently of the other.

Other proportions of the warp threads are arranged in the same manner as the foregoing. Thus, if two series of threads are arranged in the proportion of 2 to 1, the hooks of a 600-machine will be tied up in two sections of 1-400 and 401-600 to correspond, and the harness cords will be passed through longitudinal sections of the comber-board which are respectively 12 holes and 6 holes deep, or 8 and 4. For a three-thread arrangement in 1-and-1 order, the

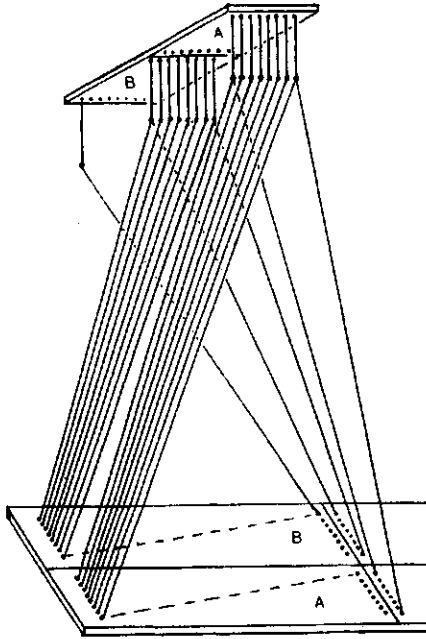


Figure A1.6



hooks and needles of a 600-machine will be in three equal sections—viz., 1-200, 201-400, and 401-600; but if there are two threads of one to one of each of the others the sections will be arranged 1-300, 301-450, and 451-600 and so on.

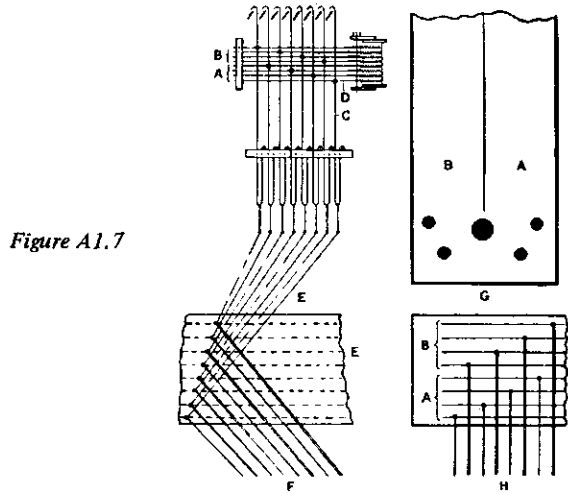
*Special connection of hooks and needles.*

Two methods are illustrated in *Figure A1.7*, either of which may be employed in place of a sectional harness tie for achieving the same results as regards the simplification of the designing. In the method illustrated by the diagram on the left the hooks C and needles D are so arranged that the four bottom needles A are connected to the odd hooks and the four top needles B to the even hooks. The harness tie and the draft of the warp threads, which are represented at E and F respectively, are exactly the same as in an ordinary machine, and it will be seen that the odd threads are controlled by the four bottom needles in each row and the even threads by the four top needles. In this system each card is divided into two longitudinal sections, as shown at G, and the lifts of the odd

threads are cut on the section A which presses against the four bottom needles, and of the even threads on the section B which presses against the four top needles.

*Special draft of the warp threads*

This method consists simply of drawing in the warp threads in such a manner that one series passes through the front half A of each short row of harness mails, as represented at H in *Figure A1.7*, and the other series through the back half B. With the needles and hooks and the harness tie arranged in the ordinary manner, the lower half of each row of needles controls one kind of warp, and the upper half the other kind, so that the system of card cutting is exactly the same as in the previous method. An advantage of the last method is that the usual form of jacquard and harness can be adapted to the special system of designing by drawing-in the warp to suit the arrangement of the ends.



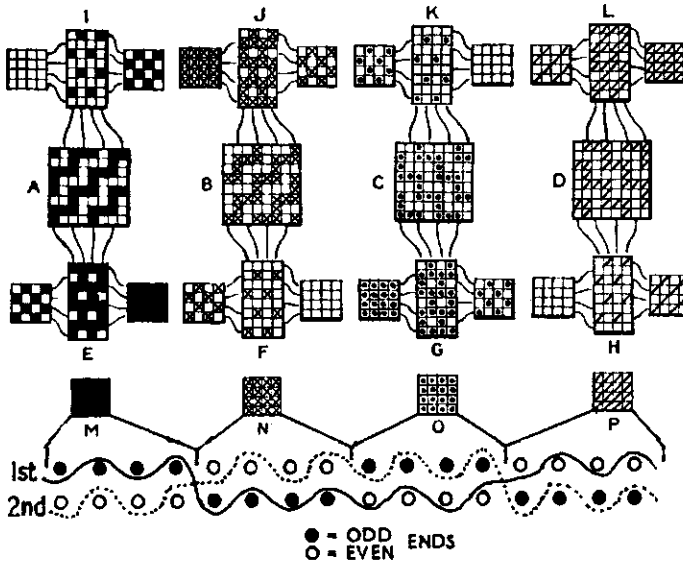
*Figure A1.7*

In *Figure A1.7* the arrangement of two kinds of warp in 1-and-1 order, only, is illustrated, but either of the methods may be applied when more than two series of ends are used.

*Designing and card cutting for sectional arrangements*

The examples given in *Figure A1.8* show how the painting out of a design is simplified by means of a sectional arrangement, and also illustrate a method of ascertaining the card-cutting particulars by which the desired structural effects will be produced in the cloth. Four different double plain weaves are given in full at A, B, C, and D which it may be assumed, are required to be combined in a design. Two series of ends and picks in the order of a thread of each alternately, are employed, and a jacquard and harness arrangement in two equal sections, as

illustrated in *Figure A1.6* or *Figure A1.7*, is therefore suitable for the arrangement in the warp. The lifts of the odd ends of the respective double plain weaves, which are shown separately at E, F, G and H in *Figure A1.8*, will be cut on one



*Figure A1.8*

section of the cards, and those of the even ends, which are shown separately at I, J, K and L on the other section of the cards. On the left of each plan E to L the lifts on the odd picks are shown apart, and on the right the lifts on the even picks. The small plans on the left and right of the examples lettered E to L thus indicate the interweaving of each kind of warp with each kind of weft in the respective weaves A, B, C, and D.

To represent the effects shown at A, B, C and D a design would be painted solid in four different colours (or in three colours, the fourth effect being represented by the paper), as indicated by the different marks shown at M, N, O, and P in *Figure A1.8*. As there are two series of threads in both warp and weft, each vertical space in the design then corresponds to two ends, and each horizontal space to two picks. Two cards are therefore cut from each horizontal space, and further, the design is cut twice—first, for the section governing the odd ends, and then for the section that governs the even ends. The plans on the left and right of the examples E to L indicate the exact order in which the cards require to be cut from the plans M, N, O and P, and in order to enable comparisons to be readily made, bracketed references are made to the respective plans in Table 3 in which the card-cutting instructions are given.

If the cards are in longitudinal sections, as shown at G in *Figure A1.7*, for convenience in the card cutting, the design paper should be ruled in fours vertically for an 8-row machine, and in sixes if the machine is 12-rowed.

As each vertical space of a design corresponds to two or more ends (according to the number of sections) the number of spaces over which a design requires to be extended is only equal to one-half, or one-third, etc., of the number of ends in the repeat. Also, as shown in *Figure A1.8*, the arrangement frequently enables

Table 3

	Section governing odd ends	Section governing even ends
First Card	Cut M plain (left of E)	Blank M (left of I)
	Cut N plain (left of F)	Cut N solid (left of J)
	Cut O solid (left of G)	Cut O plain (left of K)
	Blank P (left of H)	Cut P plain (left of L)
Second Card	Cut M solid (right of E)	Cut M plain (right of I)
	Blank N (right of F)	Cut N plain (right of J)
	Cut O plain (right of G)	Blank O (right of K)
	Cut P plain (right of H)	Cut P solid (right of L)

the painting out to be done in such a manner that more than one card can be cut from each horizontal space, so that the design is simplified in length as well as in width; furthermore in most cases the weave structure need not be indicated.

### INVERTED HOOK JACQUARDS

This type of machine is used with great advantage in weaving large designs in which two series of ends, arranged in 1-and-1 order, work exactly opposite to each other. As shown in *Figure A1.9* the jacquard is made with two sets of hooks, A and B, to correspond with the two series of ends. The hooks A have their

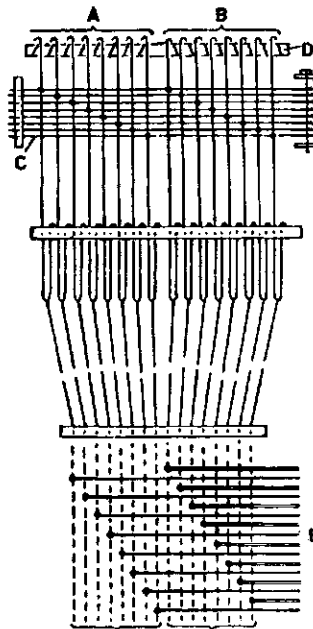


Figure A1.9

crooks turned towards the card-cylinder in the ordinary manner, whereas those of B are turned towards the spring-box. One griffe D is employed carrying 16 knives in two sets of 8 knives each, which are inclined towards the hooks that

they govern. When in the normal position the hooks A are over their knives, whereas the hooks B are clear of the other set of knives. The harness cords are tied up in the ordinary manner, but in the warp draft, which is represented at E, one series of ends is drawn upon the harness cords connected to the hooks A, and the other series upon the cords connected to the hooks B. Only one set of needles is used, but each needle is connected to a hook of each set, and thus controls an end of each series. A blank in a card presses a hook A away from the path of its lifting blade, and places the corresponding hook B in position for being raised, while a hole in a card leaves a hook A in position for being lifted, and a hook B out of action. Therefore, where ends of one series are raised, corresponding ends of the other series are left down, and *vice versa*.

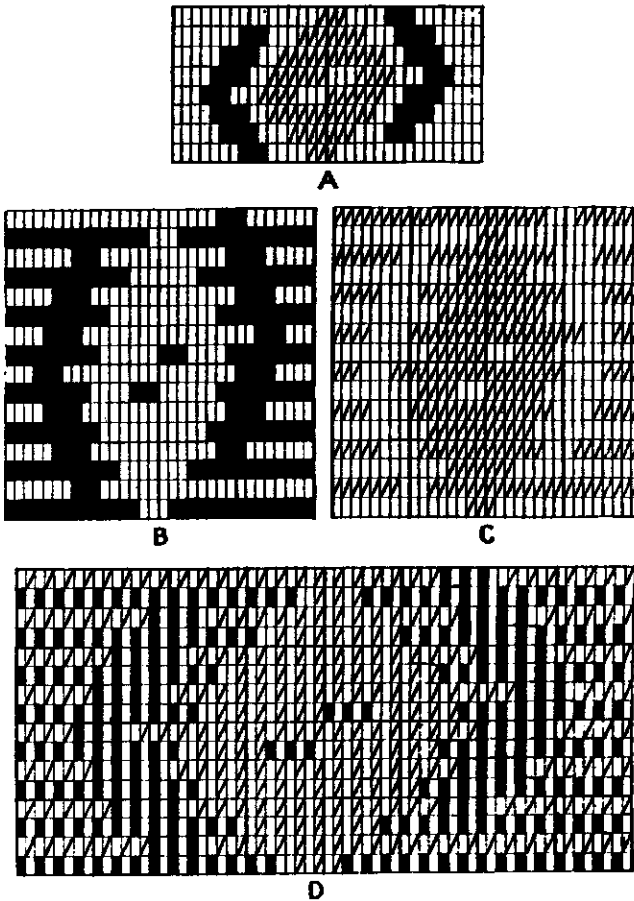


Figure A1.10

A class of fabric for which the arrangement is particularly useful is a reversible warp rib structure, in which a warp figure is produced in two colours upon plain or rib ground on both sides of the cloth. In order to show the special use of an inverted hook jacquard plans are given at A, B, C, and D in Figure A1.10,

which illustrate the development of a portion of a design from the solid system of marking to the complete reversible rib structure. The figure formed by each colour of warp is painted solid, as shown by the different marks in A, each vertical row of which represents an end of both series, and each horizontal row two picks. Assuming that the dark figure is required to be produced by the ends which are controlled by the ordinary hooks, two cards are cut from each horizontal row, as follows:

First card—cut all except the marks of the light figure.

Second card—cut only the marks of the dark figure.

B in *Figure A1.10* shows the lifts that are cut on the cards and are formed by the ordinary hooks, while C, which is exactly opposite to B, shows how the other threads are raised by the inverted hooks. As the ends are drawn through the harness in 1-and-1 order, an end of B is followed by an end of C, and the complete weave is, therefore, as indicated at D.

The inverted hook arrangement not only enables a very simple method of designing to be employed, but a design is produced that repeats upon twice as many ends as there are needles in the machine.

The system is also ideally suited for the production of interchanging figured terry pile fabrics (see Chapter 14) where one needle produces a loop on the face in one colour and a loop on the back in another colour, the construction of one loop being exactly opposite from the other. In terry weaving the inverted hook machine is assisted by a heald mounting controlling the ground ends.

The principle of inverted hook operation is used at present in the production of some jacquard leno fabrics (see Chapter 12) and also in the weaving of certain figured warp pile structures (see Chapter 16) whilst the inverted keyhole system represents an adaptation of the same principle for cordage jacquards described in Chapter 15.

## WORKING COMBER-BOARDS

In this system each harness cord is knotted in such a position that the knot rests on the comber-board when the harness mail is at the bottom line of the shed. The knots do not prevent the cords from being raised individually by the jacquard in the ordinary manner, whereas by lifting the comber-board all the cords, whose knots rest upon it, are raised together. The use of a single working comber-board to achieve solid lifts of all figuring threads on certain picks is described in connection with figured warp pile fabrics in Chapter 15. For patent satin and figured pique fabrics a system was developed in which two working comber-boards acted in conjunction with healds and a special method for card presentation to increase the figuring scope of the jacquard, save cards, and to simplify the designing and card cutting.

The arrangement suitable for patent satin structures (see Chapter 5) is shown in *Figure A1.11*. In these structures the weft is inserted in pairs, two fine ground picks being followed by two coarse figuring picks. The stitching ends are controlled by two healds, A and B; the ground ends are controlled by the harness which is knotted above the comber-boards, C and D. Two adjacent ground ends are attached to the same hook, 1 to 8, but pass through separate comber-boards.

To produce the structure the various shedding mechanisms are operated in a sequence indicated at I. The two healds, A and B, operate alternately 2 up, 2 down, changing places between the two fine, and again between the two coarse picks which in the fully worked-out weave F is represented by the crosses. On the fine picks the two comber-boards, C and D, lift alternately producing plain weave between the ground weft and ground warp, as indicated by the dots at F, and as seen in the weft section at G. On the two coarse picks (picks 3 and 4 of the sequence) the comber-boards are inoperative and the lifts of the ground ends are obtained from the jacquard hooks, E, upon presentation of the same card for both the coarse picks, as shown by the solid marks at F. Due to the fact that all

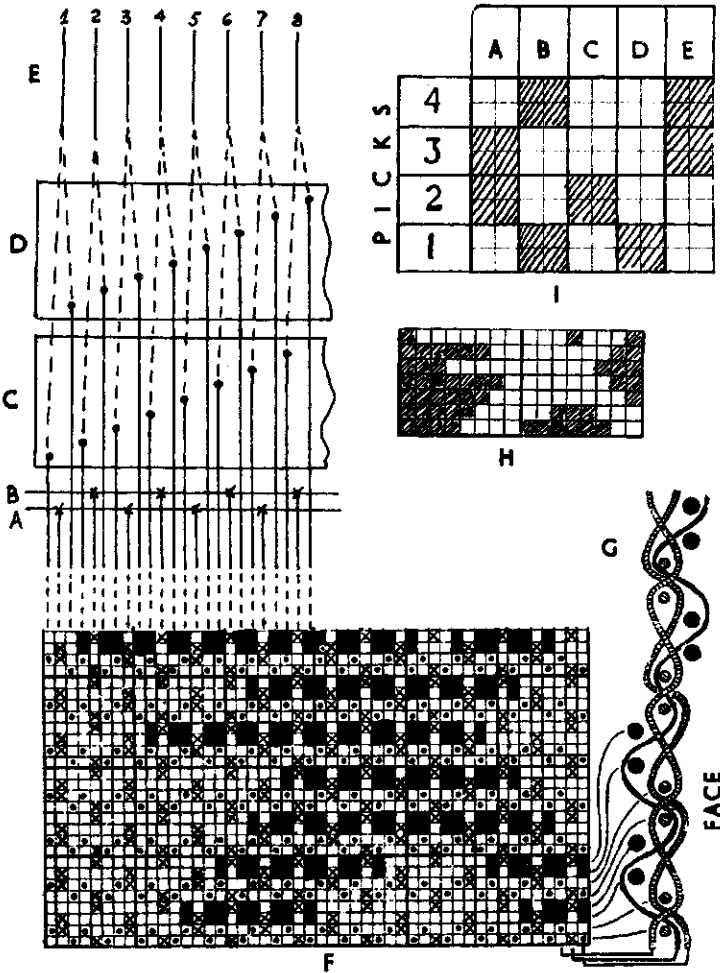


Figure A1.11

the lifts, apart from the figuring lifts of the ground ends, are independent of the jacquard the designing is considerably simplified. This is shown at H where the areas in which the figuring weft forms a float on the surface are painted solid, as



indicated by the shaded squares. The design is cut according to the following simple instructions: Cut one card from each horizontal row, cut blanks. As each card acts for two figuring picks in succession and each vertical row of the design represents two ground ends, the floats of the figuring weft are automatically enlarged by two in each direction which is clearly indicated in the full weave given at F. The total enlargement of the simplified design which occurs in this system is by 3 warp-wise and by 4 weft-wise with the result that an area of 16 vertical by 7 horizontal rows represented at H in the actual cloth contains 48 ends and 28 picks.

The working comber-board arrangement for figured piques, the structure of which is described in Chapter 4, although superficially similar to the one used for patent satins, is employed for an entirely different purpose. As shown in *Figure A1.12*, the ground ends in this mounting are operated by the four healds 1, 2, 3 and 4 in which they are skip drafted. Due to this method of drafting only

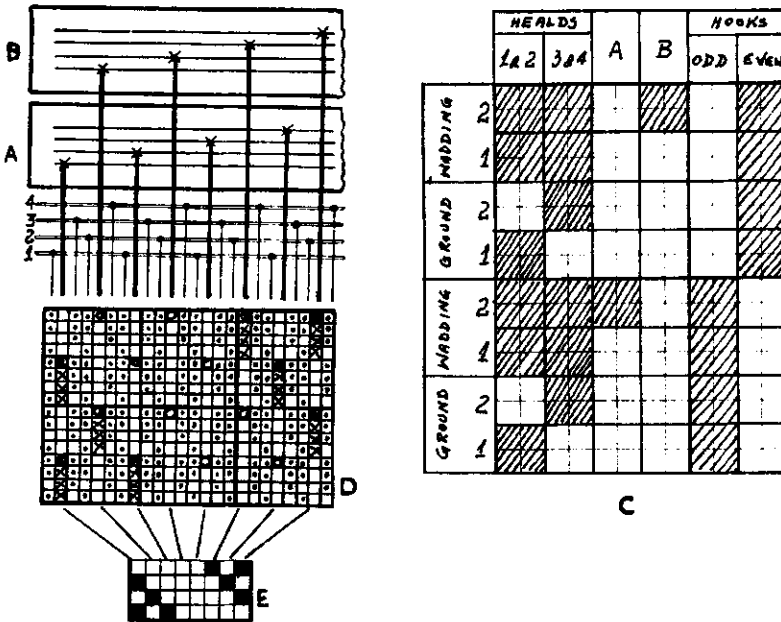


Figure A1.12

two tappets are required, healds 1 and 2, and 3 and 4 being operated as one in pairs. The stitching ends which in this structure are, in fact, responsible for the formation of figure are jacquard controlled. One card acts for a number of picks equal to the length of stitch, i.e. for two to six picks depending on the construction. When the stitching ends are not required to form a figuring stitch on the face the jacquard leaves them down to float idly on the back. As the back floats may be very long, it is desirable to stitch them in a regular order to the back of the structure. This, however, cannot be done through jacquard selection because each card is pressed in for several picks in succession and a jacquard stitch invariably shows on the surface as a figuring stitch and that is the reason for using the working comber-boards. The latter are raised only on wadding picks in plain order and ensure that no long floats are formed on the underside.

The lifts of the comber-boards A and B are synchronised with the figuring lifts of the odd and even hooks so that the understitch never occurs in the wrong place. The sequence in which the various shedding mechanisms operate in a 4-pick structure is depicted at C in *Figure A1.12*. In the fully worked-out weave at D the heald lifts are shown by the dots, the comber-board lifts by the circles, and the jacquard lifts by the crosses. The full weave area at D corresponds exactly with the simplified design E and shows clearly the degree of magnification which results. The instructions for the design E are simply: Cut one card from each horizontal row, cut marks. The healds and the comber-boards in this, as well as in the previously described system, are usually operated by positive tappets.

A different system, using four working comber-boards in conjunction with a twin inverted hook jacquard, was at one time used for the production of double plain Kidderminster carpets. The comber-boards were employed to produce the two plain cloth layers whilst the jacquard only determined which layer at any given time occupied the top position and which the bottom position. Although the system achieved considerable degree of simplification in designing and card cutting, it was so inflexible that it was discarded in favour of the sectional harness systems when more varied forms of ingrain carpets became fashionable in the nineteenth century.

### STRING DOUP MOUNTINGS FOR LENO WEAVING

The string doup mounting was at one time used extensively for many leno constructions; at present lenos are woven mainly in steel doups described in Chapter 12.

#### *The doup*

In *Figure A1.13* at X, Y and Z the different types of string doups are represented, X and Y showing two methods of connecting the half-heald to an ordinary heald, while Z shows how it is connected to a jacquard harness. The crossing ends pass through the loops of the half-heald where indicated by the dots, and in the direction shown by the arrows; and it will be noted that while in X and Y the half-heald is permanently connected to the ordinary heald, in Z the loop is held in position by the warp thread. The first method is more convenient in drawing in the warp and in repairing broken ends. The advantage of the latter method is that the doup, which wears out much more rapidly than the harness, can be readily replaced; but on the other hand, if the crossing ends are absent, the loops will slip out of the mail eyes.

#### *Bottom and top douping*

The half-heald may be placed with the lath below the warp, as shown in *Figure A1.13*, or above, the position in the latter case being represented by the diagrams in *Figure A1.14*. Bottom douping is more commonly employed, as it is simpler to follow, is more conveniently applied in the loom, and the lift is not so heavy.

This method, however, makes it necessary for certain styles to be woven wrong side up. In top douping the parts are better under the observation of the operative, and the repairs to the half-heald are more readily effected; but if a loop breaks, as it hangs down, it is liable to become entangled with the warp and cause breakage, while the tension on the crossing ends, when a spring-reversing motion is used, makes it difficult in some cases to get a level bottom shed line.

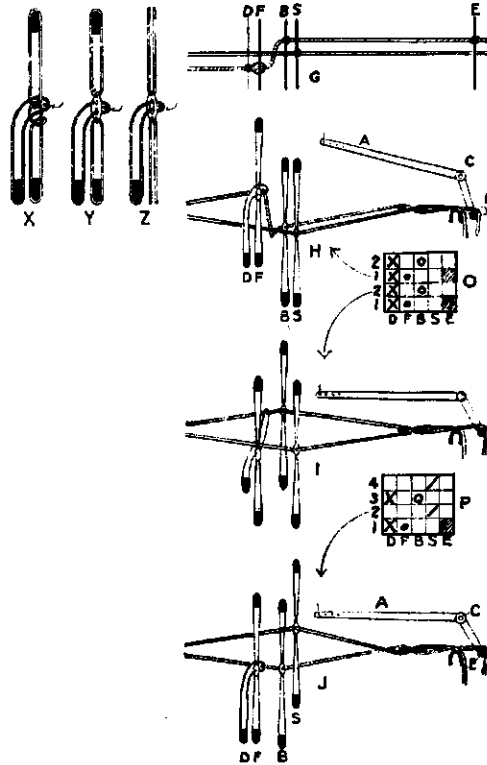


Figure A1.13

In practice, the use of the top doup is generally limited to styles which require to be woven right side up, and can only be thus produced with the top doup. For some patterns which require two doups it is found advantageous to use both methods together.

*Leno drafting*

For the simplest style of doup weaving the following healds are necessary: A half-heald or doup, lettered D in *Figures A1.13 and A1.14*; a front-crossing heald F, to which the doup is attached; a back-crossing heald B, through which the crossing ends are drawn; and a standard heald, S, which carries the standard ends. (In practice the terms very largely used for the healds are respectively—doup, front standard heald, back standard heald, and standard heald, or

sometimes ordinary heald. It is considered that the former designations are less liable to lead to confusion, the term standard being used only for the healds which carry the standard ends, crossing for the front and back healds which operate the crossing ends, while ordinary will be applied to healds which are not used for the douped effect, but to produce some other weave). G in *Figure A1.13* shows a bottom doup draft in which one end crosses one end. In drawing in the warp the ends are drawn through the back crossing heald B and the standard heald S in the ordinary manner. Then the front crossing heald F and doup D are placed in front, the standard ends are drawn between the leashes of F, while each crossing end is passed under the standard end and drawn through a loop of the doup D. In top douping the crossing ends are passed over the standard ends, as shown at K in *Figure A1.14*. The crossing ends may cross the standard ends either from the left or from the right. No ends are drawn through the mails of the front crossing shaft, the purpose of this heald being simply to support the half-heald.

#### *Relative position of the healds*

In mounting the healds in the loom, in order to reduce the acuteness of the angle formed by the crossing warp when the crossed shed is made (shown at H and L in *Figures A1.13* and *A1.14*) it is customary to allow a greater amount of space between the front and back crossing healds than between the other healds. In the drafts G and K in *Figures A1.13* and *A1.14* the back crossing heald is shown next behind the front crossing heald. The position is a matter of opinion and by some it is preferred to have the back crossing heald behind all or a portion of the other healds as the further back it is placed the less acute is the angle formed by the crossing ends when the crossed shed is made, and there is, therefore, less strain on the crossing warp. However, so long as sufficient space can be obtained between the back and front crossing healds, the former may with advantage be placed next behind the latter, as then there is no liability of friction and entanglement of the crossing ends with the leashes of the other healds.

In addition to the healds an easer bar (or bars) is provided at the back, labelled E in *Figures A1.13* and *A1.14*, which is operated in the same manner and for the same purpose as described in Chapter 12 in connection with the steel douns.

#### *Sheds formed in doup weaving*

These are illustrated for bottom douping, at H, I and J in *Figure A1.13* and for top douping at L, M and N in *Figure A1.14*. The formation of the *crossed shed*, which is the chief feature in doup weaving, is shown at H and L in the two figures. When this shed is formed the crossing ends are moved out of their normal position to the opposite side of the standard ends. In bottom douping the doup D and the front crossing heald F are raised, and the back crossing heald B and the standard S are left down, as shown at H; while in top douping the position of the healds is exactly the reverse, as shown at L. The crossing ends, being held by

the back crossing heald in one line of the shed, and by the doup and front crossing heald in the other line, pass almost at right angles from one to the other; hence a greater length of crossing warp is required from the fell of the cloth to, say, the lease rods than when these ends are in the normal position. The easer A, is, therefore, operated at the same time as the front crossing heald, and the easing bar E is moved in from the position represented by the dotted circle; the additional length of crossing warp required thus being given in.

The formation of the *open* shed, in which the crossing ends are operated in their normal position, is illustrated at I and M in *Figures A1.13* and *A1.14*. In bottom douping the doup D and the back crossing heald B are raised, and the front crossing heald F and the standard S are left down; the loops of the doup being drawn under the standard ends and lifted with the crossing ends when the

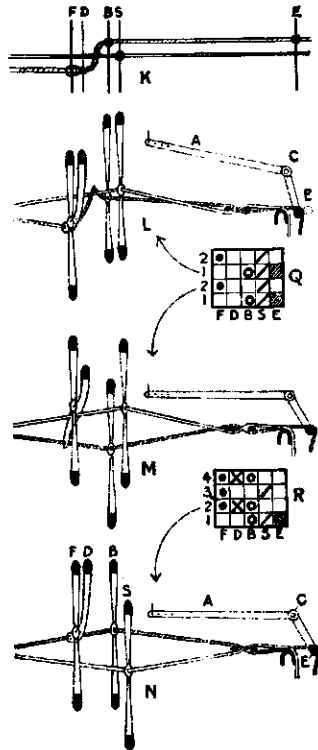


Figure A1.14

latter rise on the normal side of the standard ends, as shown at I. In top douping exactly the opposite conditions prevail, as shown at M. When this shed is formed the lever A is depressed and the easing bar E is moved outward, the stretch of the crossing warp thus being increased to the normal.

J and N in *Figures A1.13* and *A1.14* show the formation of a plain shed in which the standard heald only is raised in bottom douping, while only that heald is depressed in top douping. The easing bar E is again in its outward position.

The correct setting of the doup is of the greatest importance as regards the prevention of broken ends and undue wear of the loops. Its height should be

carefully regulated, and it should move exactly in accordance with the movements of the front and back crossing healds. Thus, in bottom douping, if it is not raised sufficiently the loops will drag on the crossing ends, or on the leashes of the front crossing heald. On the other hand, if it is raised too high the loops will slide through the eyes of the front crossing heald when the cross shed is formed, while they will hang slack and be liable to become entangled on the open shed. Also, in order to facilitate the crossing movement, the standard heald should be set slightly higher in bottom douping and rather lower in top douping than the healds which operate the crossing ends.

### *Construction of lifting plans*

O and Q in *Figures A1.13* and *A1.14* show the lifting plans for bottom and top douping respectively when the crossed and open sheds are formed alternately, the picks numbered 1 in the respective plans corresponding with the drawings shown at H and L, and those numbered 2 with I and M. The plans P and R similarly show the order of lifting when a plain shed is formed between the crossed and open sheds, the picks numbered 1 respectively corresponding with H and L, 3 with I and M, and 2 and 4 with J and N. The crosses represent the lifts of the doup, the dots of the front crossing heald, the circles of the back crossing heald, and the diagonal strokes of the standard, while the shaded squares show when the easer is operated. It will be noted that four spaces, D, F, B and E, are provided for showing the operation of the crossing ends. The easer is always moved when the front crossing heald is brought into action, while the doup is operated with both the front and the back crossing healds. In practice, therefore, the lifts of the easer and the doup are frequently omitted from the lifting plan, as the other marks of the plan readily indicate when these should be operated. Also, in order that there will be absolute certainty of the movements being in unison, in bottom douping especially, the easer is sometimes connected to the shedding lever that controls the front crossing heald; while the lath of the half-heald is connected to the back crossing heald lever, and also by cords to the lath of the front crossing heald on the opposite side of the shed.

In jacquard lenos the string douns are connected to douping harness which performs the same function as the front crossers in dobby weaving. The main part of the harness acts in the manner of back crossing and standard healds whilst another part is reserved for the easing operations. The range of jacquard structures produced with string doup is similar to that described in respect of steel douns in Chapter 12.

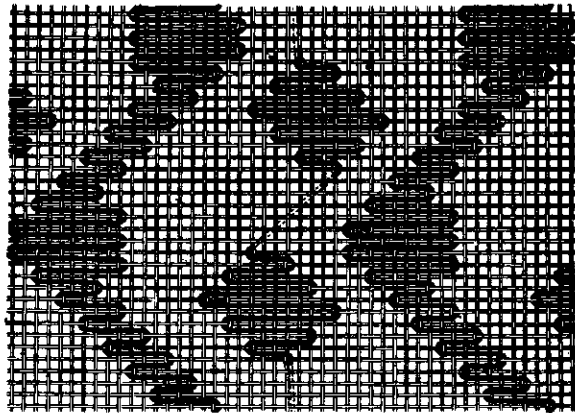
## Appendix II

# Uncommon Woven Structures

### LAPPET WEAVING

Lappet fabrics can be basically classified as extra warp structures in which the extra material forms an opaque figure on an open, semi-transparent ground. The fabrics are particularly popular in the Middle East where they are often used as shawls and other traditional items of attire. Due to the difficulties of manufacture however, they are produced by only a small number of specialist firms.

The ground weave is usually plain and is constructed in two or four healds with the aid of a negative tappet assembly. The ornamentation of ground fabric consists of crammed or cord ends, coloured stripes and other such devices which do not call for the use of additional shedding mechanisms in the form of dobbies or jacquards. On this plain ground the extra warp threads, known as whip threads figure in a manner entirely foreign to warp threads by traversing horizontally across the ground ends, each such traverse forming one float of a figure



*Figure A2.1*

which is built entirely from a succession of these transverse laps as shown in *Figure A2.1*. As the crosswise movement of the whip thread takes place under the ground warp line, and the action occurs between picks, two points become

obvious: (1) The fabric is woven face side down; (2) no interlacing of the float is possible in the middle of its traverse. The float can be bound only at each extremity which clearly imposes a certain limit on the extent of each traverse.

From this description it is clear that two distinct and independent movements of the whip thread are necessary—the horizontal or figuring movement which produces the float, and, at the end of each traverse, a vertical or stitching movement which binds this float to the ground cloth and thus determines its extent and position.

### The figuring movement

The figure-forming elements of the lappet system are represented in the schematic diagrams in *Figure A2.2*. The whip threads, W, are drawn upon needle bars, D, which are thin slats of wood with eyed needles, N, spaced at intervals. These are the chief control and shedding elements for the extra yarn. The needle bars are fixed on shifter bars, R, in such a way that any horizontal movement

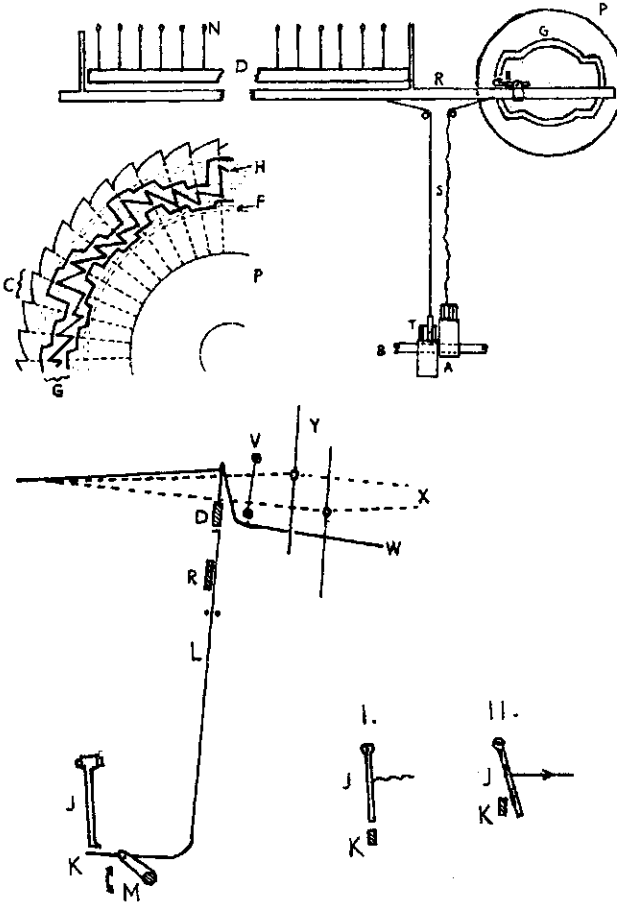


Figure A2.2



of the shifter bar has to be followed by the needle bar. The horizontal oscillating movement of the shifter bar is obtained through strap connections, S, and treadles, T, from a set of tappets, A, and these are timed to give a traverse from left to right between, say, picks 1 and 2, and traverse from right to left between picks 2 and 3, in this way giving the required sideways deflection of the shifter bar, the needle bar, and therefore the whip yarn. The tappet stroke and the treadle leverage are designed to give to the shifter bar a maximum movement of about 10 cm, and if the shifter bar were left at the mercy of the tappet alone, the whip thread would merely produce 10 cm traverses in both directions, resulting in a broad vertical bar composed of excessively long floats. This is where the patterning mechanism takes control.

The pattern or selection mechanism is so designed that it is capable of arresting the tendency of the shifter bar to move from one extreme of its stroke to the other; in other words, the selection mechanism is able to form the pattern by over-ruling the dictate of the tappet assembly. When the tappets demand the shifter bar to move 10 cm to the left, the pattern mechanism will let it move only, say, 8 mm to the left; when, between the next pair of picks, the tappets dictate a shift of 10 cm to the right, the selector may allow a movement of only, say, 4 mm to the right.

The pattern-forming unit does not, therefore, conform to the usual concepts of such a mechanism. It is, in fact, a novel type of selection device, and consists of a large wooden wheel P, in *Figure A2.2*, in which a deep groove, G, is cut. The groove is the actual pattern track for a peck or feeler, E, which is rigidly connected to the shifter bar and restricts its movement when it stops first against one wall of the groove, then against the other, in this way ignoring the tendency of the tappet to move farther. Obviously with such an arrangement there cannot be a rigid connection between the shifter bar, the treadle, and the tappet. The arrangement is such that the treadle follows the tappet merely by resting upon it, and is itself connected to the shifter bar by a leather strap. When the peck is stopped by the pattern groove wall, the weighted treadle lever is prevented from following the diminishing diameter of the tappet and hangs suspended on its leather strap, as shown in respect of the left-hand strap, S, in the upper diagram in *Figure A2.2*.

The maximum patterning capacity of lappet looms is four independent needle bars; therefore, up to four shifter bars may be employed, each with its peck working in a separate pattern groove of the wheel. Each pattern groove may give a distinct order of lapping and therefore four different figures may be formed simultaneously.

The pattern wheel itself is rotated one tooth (C in *Figure A2.2*) in two picks by a spring-loaded hook operated from a separate tappet on the bottom shaft. This means that the peck will perform both the traverse to the left and the traverse to the right within the radial space represented by one tooth. This does not preclude the possibility of one traverse being longer or shorter than the other, as can be observed by following the path of the peck, H, in the enlarged view of the pattern wheel in *Figure A2.2*.

### *The stitching movement*

At the end of each horizontal traverse the whip thread normally proceeds above the ground warp line in order to be stitched to what will finally become the

underside of the fabric. This vertical lifts of the whip thread presupposes a vertical lift of the needle bar, and this is the reason why the needle bar is not permanently clamped upon the shifter bar. The shifter bar-needle bar connection is a rigid one only as far as lateral movement is concerned: the needle bar is quite free to move vertically. Since the shifter bar is incapable of imparting any vertical movement, a separate mechanism is required. This is provided by rods, L, in *Figure A2.2* which support each needle bar from underneath at each end. These rods pass between the shifter bars without obstructing them, and the needle bars can still move sideways freely under the impulse of the shifter bar by sliding upon the flattened tops of the rods. The rods are also quite free to move up and lift the needle bars so that the whip threads are forced into the upper shed line, the shuttle passing under them, in this way stitching the extra thread to the upper side of the cloth.

Normally the whip threads are raised after every pick. If, however, it is desired to create a longitudinal or diagonal float on the face of the fabric, vertical movement of the whip threads must not take place; therefore there must be means of control and selection that will enable the stitching lift to be governed at will. This selective control is provided by the pendants, J in *Figure A2.2*, which in their normal position lift the rods and the needle bars, but which can be moved sideways, in this way preventing a lift from taking place. The pendants, four at each side to serve the four needle-bar rods are connected by cords to hooks which work at the back of the pattern wheel. These hooks are in their rest position, with pendants vertical, when normal stitching takes place. In places where this is not required a semi-circular baffle plate will be inserted at the back of the wheel to correspond with a certain number of picks during which the stitching is to remain inoperative. When the baffle plate moves opposite the hook, the hook will be deflected and through its cord connection will move the pendant sideways, thus preventing a lift of the rod. The operative and inoperative positions of the pendants J are indicated respectively in supplementary diagrams I and II in *Figure A2.2*.

To achieve the stitching movement a short lever, M, mounted on the rocking shaft lifts the toe, K, of rods, L, against the pendant, J, as the sley moves back. The toe, K, pivots against the pendant which causes the upward movement of the rods, and the shifter bars which rest upon them. If the pendant is withdrawn no pivot point is provided for the toe, K, and no lift can take place as the heel of the rod L, rests against the rocking shaft. During the forward movement of the sley the rocking shaft turns the lever, M, downwards causing the rods, L, to fall so that the tips of the needles are below the cloth line in readiness for the next lateral figuring movement.

### *Auxiliary mechanisms*

In this system of weaving there are certain important auxiliary mechanisms. One of these is the pin bar. The reed in this system is very far back because it has to accommodate in front of it the series of needle bars which move the whip threads horizontally or vertically, and these actions must take place in front of the reed to be effective. As a result, during shed forming, which is a combined operation shared between the healds controlling the ground ends and the needle

bar controlling the extra ends, the reed cannot serve as a back support for the shuttle because of the presence of needles in front of it. Therefore, since the precision of shuttle flight is not sufficiently good, some other type of shuttle guide must be provided. This is given by the pin bar, which is similar to a needle bar but does not carry any yarn. Its sole function is to serve as a false reed during picking. It will therefore rise in common with needle bars just prior to picking and immediately after picking it will recede, again together with the needle bars, so that the reed can come forward without any obstruction to beat up the last inserted pick of weft. Since the action of the pin bar is so similar to the action of the needle bar, it will be operated from the same type of rod and from an identical source. The only difference is that the pendant against which the pin bar is acting will be permanently blocked, since the pin bar will move up without fail before every pick.

Another auxiliary mechanism of some interest is the tensioning mechanism for the whip threads. Because of different uptakes, the yarn supplying each of the four needle bars must be placed on a separate small beam (known as a whip roll), and it must be separately tensioned. The tension is delicately balanced, because the yarn should be taut enough to form a clear shed and to prevent curling of the horizontal float, and yet no undue pressure must be exerted at

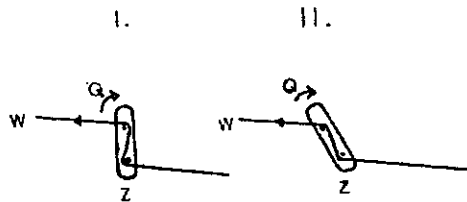


Figure A2.3

the end of each traverse, as this would pull and distort the ground ends. Also, the whip thread is subjected to sudden demands when the needle bar moves laterally and when it rises to form the shed, and the excess of yarn given at that moment must be readily removed when the needle bar moves down again. It would be difficult to obtain the necessary delicacy of balance together with the oscillation directly from the roll, and therefore a separate spring-loaded mechanism is provided between the small beam and the needle bar as shown in *Figure A2.3*. At I the whip thread, W, is represented in its normal position, running between two cords in the frame Z which is springloaded in the direction shown by the arrow Q. When a sudden demand for extra length of yarn is transmitted the delicately balanced frame overcomes the springloading and swings to a horizontal position as shown at II. This position, apart from satisfying the sudden demand, permits the yarn to slip easily between the cords and deliver a length by rotating the roll.

#### *Relation of movement of shifter bars to rotation of pattern wheel*

The turning of the pattern wheel, which occurs only once in two picks, may be arranged to coincide with the movement of the shifter frames, either to the right

or to the left. In most designs, however, it must agree definitely with one of the movements, according to the way in which the pattern grooves have been cut. There is no hard-and-fast rule; thus, a system may be followed, for both right-hand and left-hand looms, of having the rotation of the wheel coinciding with the movement of the pecks—(1) from left to right or (2) from the outside to the inside of the grooves.

*Figure A2.4* illustrates how necessary it is, in certain patterns, for the rotation of the wheel, the movements of a shifter frame, and the manner in which a pattern groove is cut, to coincide with each other. In A, which illustrates the traversing of a whip thread, as viewed from the upper or wrong side of the cloth, the vertical spaces represent the splits of the reed, and the horizontal lines the picks of weft, the pattern extending over 20 splits and 30 picks. The whip thread is shown traversing 6 and 4 splits alternately, except where the pattern turns, in which positions consecutive moves of 6 splits are made. B shows a section of the pattern wheel in which the dotted concentric lines correspond with the splits, and the dotted radial lines with the moves to the left of the whip threads as shown by the connecting lines; while the thick solid lines indicate the edges of the groove, which repeats on 15 radial lines, or one-third of the diameter of the wheel. The width of two splits only is, for convenience, allowed for the diameter of the peck, and the groove is, therefore, shown two concentric spaces wider than the distance that the whip thread is required to be traversed. The arrangement is for a left-hand loom, and as the movement from left to right (the odd horizontal spaces of A) is taken to coincide with the turning of the wheel, the centre of the peck will traverse the concentric spaces as shown by the solid lines within the groove. It will, of course, be understood

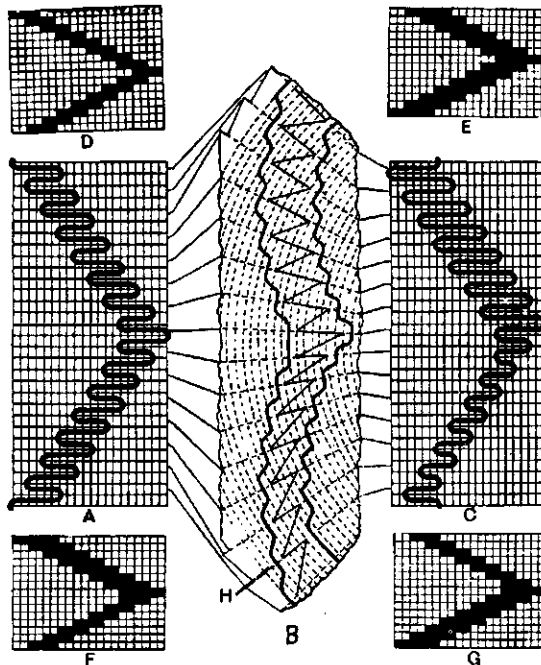


Figure A2.4

that the movement of the centre of the peck is always in a horizontal plane in line with the centre of the wheel. When the peck is moved from right to left (the even horizontal spaces of A), its centre follows a radial line and the lateral distance traversed by a whip thread is equal to the width of the groove minus the diameter of the peck, or  $6 - 2 = 4$  splits in the lower portion, and  $8 - 2 = 6$  splits in the upper portion of B. This does not apply to the movement from left to right, as while this is about to take place the wheel turns, and the peck, therefore, moves opposite a new position in the groove; the distance traversed being greater in this case where the inner edge is approaching the centre of the wheel and less where it is receding from the centre. It will thus be noted that in order to obtain the alternate movements of 6 and 4 splits in each half of the pattern, the groove is narrower in the lower than in the upper portion of B; and a representation of the form of the groove (leaving out of account the diameter of the peck) in solid marks on design paper, will not be as indicated at D or E in *Figure A2.4*, but as shown at F.

C in *Figure A2.4* shows how the pattern would be affected if the rotation of the wheel took place at the opposite movement of the shifter frame to what the groove has been cut for. In that case the turning of the wheel would coincide with the movement of the peck from right to left, and, compared with A, the traverse of the whip threads would be curtailed by the lower portion of the groove, and increased by the upper portion. With the latter timing of the rotation of the wheel, in order to produce the effect given at A, the groove would require to be cut according to the plan indicated at G.

### *Representation of lappet designs*

In many cases the wheel cutter is simply provided with a sketch of the figure that it is desired to produce, and he prepares the plan from which the wheel is cut. In constructing a plan for the wheel-cutting squared paper may be used with advantage and different methods of representing a figure are shown in *Figure A2.6* in which each plan corresponds with the pattern given in *Figure A2.5*. The design repeats on 50 ends and 42 picks, or 25 splits of the reed,



*Figure A2.5*

and 21 teeth of the wheel, and the differently shaped figures, arranged in alternate order, are formed by one needle bar. A in *Figure A2.6* shows exactly how the whip threads are traversed in the cloth as viewed from the wrong side, each

vertical space representing an end, and each horizontal line a pick. The dotted lines show the portion of thread which is cut away after the cloth is woven, leaving the figures quite detached from each other. If the count of the design paper is suitable for the proportion of ends and picks in the cloth, this method gives an accurate representation of the effect; but it is not convenient for the wheel cutter, since two vertical spaces correspond with one split of the reed, or one circular space of the wheel. By using paper in which each large square is divided into spaces in the same proportion as the splits per unit space are to the picks per unit space—as, for example, for a square cloth into 4 spaces vertically, and 8 spaces horizontally—a convenient representation of the design may be

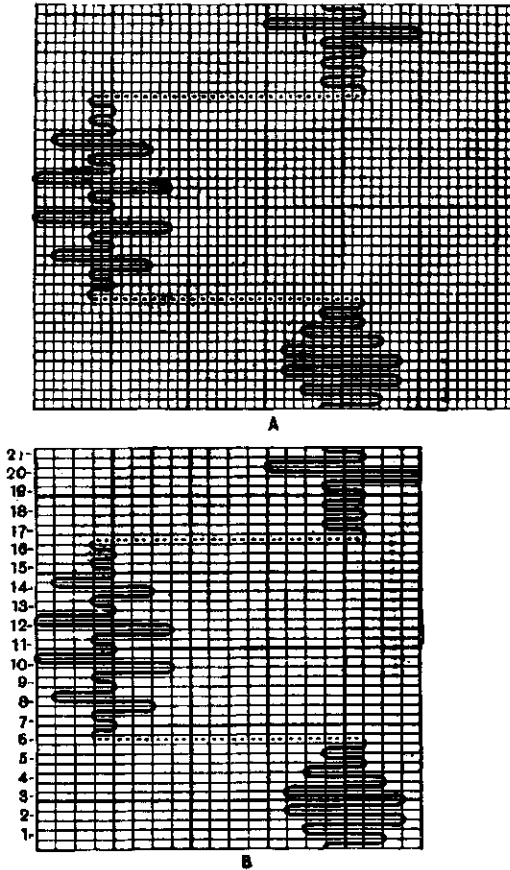


Figure A2.6

made. Thus, B in *Figure A2.6* shows the design A worked out on 4 × 8 paper, each vertical space of which represents a concentric space in the wheel and each horizontal line a pick. The full width of the repeat is not shown in this plan, as the wheel cutter is concerned only with the space over which a thread is required to be traversed. The accurate repetition of the figure in width is dependent upon the spacing of the needles in the bar. In the method shown at B the outline of a figure may be first drawn to scale on the paper in the ordinary manner, and then the required moves be indicated, as represented in the example.

*Construction of a lappet pattern wheel*

Lappet wheel is made from hard, fine grained wood. Its thickness is from 15 to 25 mm, and its diameter varies from about 20 to 60 cm, according to the number of picks in the repeat, and number of frames employed in forming a pattern. A hole is bored, about the centre of a piece of wood of suitable size, to fit the socket of a lathe, in which it is turned to the proper diameter. On the side of the wheel where the groove or grooves are to be cut, a steel comb is pressed while the disc is revolving, a number of concentric lines thus being made, the space between which corresponds with the pitch of the comb. Combs are made to suit different reeds, and for below about 14 splits per cm it is usual to use a comb of the same pitch as the reed for which the design is intended. With more splits per cm the fineness of the marking presents a difficulty, and a comb may then be used which is one-half the count of the reed, the half distance between the marks being judged by the eye in indicating the shape of a groove. The concentric lines may be marked to within 12 mm from the edge of the wheel, and another line is then marked about 5 mm from the edge to indicate the depth of the teeth. The circumference is next divided into as many equal parts as the number of teeth required, each tooth representing two picks, and radial lines are drawn from the divisions to the centre of the wheel. The teeth are then cut the required depth with the edges in line with the radial lines. Each engagement of the turning catch brings a radial line in a horizontal plane with the centre of the wheel and the centre of a peck moves upon this line.

A system of indicating the edges of a pattern groove is illustrated in *Figure A2.7*. The example corresponds with the effect represented in *Figure A2.5* and *A2.6*, and the marking of the groove will be readily followed by comparing it with B in *Figure A2.6*. The arrangement is for a left-hand loom, and the full repeat of the design is represented on one-half of the wheel. The moves to the left in B, *Figure A2.6*, are numbered to correspond with the similarly numbered radial lines of the wheel, and the first vertical space in the plan B coincides with the first concentric space in *Figure A2.7*. Commencing with the position marked 10, where the whip thread is at its farthest point to the left, the outer edge of the groove is marked on the first concentric line. At 11, the edge is marked on the fourth line, or three spaces inward, at 12 on the first, at 13 on the fourth, at 14 on the second, at 15 and 16 on the fourth, and at 17—where the groove changes position for the commencement of the other figure—on the fourth, and also on the sixteenth line, or 15 spaces inward. The position of the outer edge is thus indicated where the concentric lines cross the radial lines, until the complete circle of the wheel has been made.

In marking the position of the inner edge, it is first necessary to find the width of the groove at one position, by adding the number of spaces which the diameter of the peck is equal to, to the number of spaces traversed by the peck at this point. If the diameter of the peck is 5 mm with 10 spaces per cm, 5 spaces are added to the traverse; with 8 spaces per cm 4 spaces, and so on. In *Figure A2.7*, 4 spaces are allowed for the diameter of the peck, and commencing with the position marked 10, it will be noted that the traverse is 7 spaces; therefore the inner edge of the groove at this point is  $4 + 7 = 11$  spaces distant from the outer edge. When one position has thus been found on a radial line, the concentric lines are successively marked in the manner described with

reference to the outer edge. When the lines of the groove have been completed, the wood between them is carefully bored out to the required depth, say 10 mm.

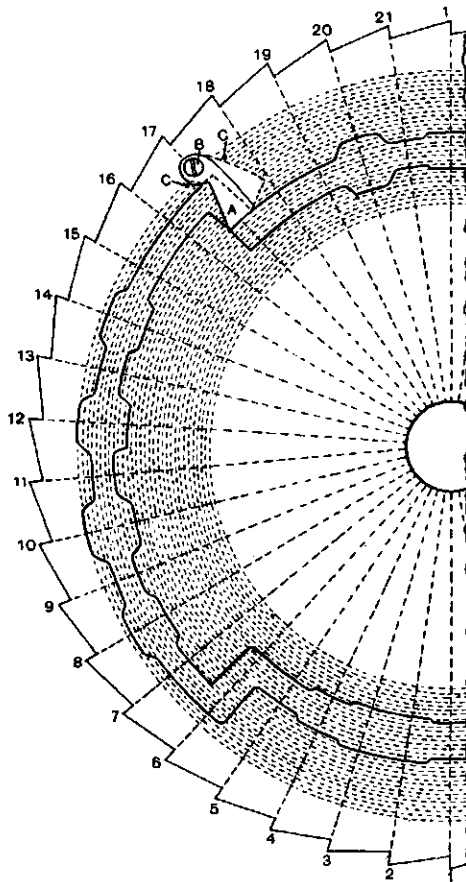


Figure A2.7

In an ordinary groove two concentric lines are sloped towards each other intermediate between two radial lines, but when the groove changes abruptly towards the centre of the wheel, as shown on the radial line numbered 17 in *Figure A2.7*, the peck is liable to catch against the approaching edge of the groove as the wheel revolves. This will be understood if the moves of the peck, in relation to the turning of the wheel, are followed. Thus, taking the radial line 16, the peck moves from the inner to the outer edge of the groove, then the wheel turns, and while this is taking place the peck is really in easy contact with the outer edge. After the rotation of the wheel the peck moves on the line 17 against the inner edge, then it moves back on the line 17, and this is followed by another rotation of the wheel. If allowed to pass the corner of the outer edge in moving back, the peck would lock the wheel, and in order to avoid this a small catch A, centred freely at B, is provided. When the peck is moving on the line 17 from the outer to the inner edge of the groove, it pushes up the



catch A to the position shown by the dotted lines; but when the return movement takes place the catch has dropped and the peck moves against its edge. The catch is shaped in conformity with the edge of the groove, and two pins C are driven into the wheel to limit the extent of its movement.

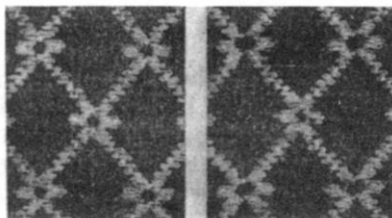
There is a similar abrupt change in the position of the groove on the radial line 6, but as the move is away from the centre of the wheel no catch A is necessary. Thus, on the radial line 5 the peck moves from the inside to the outside of the groove; the wheel turns, and the peck moves against the inside on the line 6, then on the same line against the outside, and while it is in this position the wheel turns again. The catch A requires to be placed on the side of the groove that the peck is in contact with when the wheel commences to turn.

A feature to note in *Figures A2.4 to A2.7* is that each design repeats on an odd number of teeth of the wheel. This is frequently necessary when a symmetrical effect is required. Thus in *Figure A2.4* in order that both turning points of the waved line will be exactly the same, it is necessary for the half repeat to be made on an odd number of picks, while in *Figure A2.6*, in obtaining the moves from one spot to the other without the needle bar dropping, it is necessary for an odd number of picks to be employed for each figure. An even number of teeth could be employed for a style such as the latter by making one figure 2, or 6, etc., picks longer than the other.

#### *Multi-frame lappet designs*

*Figure A2.8* exemplifies a style of ornament produced by two frames working in combination. It will be found that aspects of the designing procedure, described in connection with this structure are also applicable to three-frame, and four-frame styles by logically extending the discussed premises.

*Figure A2.8*



The corresponding plan is given at A in *Figure A2.9*, as viewed from the wrong side of the cloth, the vertical spaces representing the splits of the reed, and the horizontal lines the picks. The repeat is on 32 splits, and 70 picks, or 35 teeth an odd number of the latter being arranged for on account of the figure being symmetrical. The full squares show the moves of the first needle bar, and the dots of the second, while the circles indicate the moves of both bars. The marks on the odd horizontal spaces represent the moves from right to left, which decide the widths of the grooves. There are three features to note in this example. (1) Where two whip threads unite to form a solid portion of figure it is necessary for the traverse to overlap. If the threads approach each other without overlapping, the side pull in opposite directions is liable to distort the ground

ends unduly, and make an open space between the two portions of the figure. In obtaining the overlap the needles do not cross each other, as both bars move in the same direction. (2) It is necessary for the distance from centre to centre of the needles in each bar to be exactly the same as the space occupied by the number of splits in the repeat. (3) The different bars require to be set so that the needles are in correct relation with each other. *Figure A2.8* illustrates good and bad setting, the pattern on the right showing the whip threads overlapping more in one central figure than in the other, while in that on the left the overlap is equal, and a perfectly symmetrical figure results.

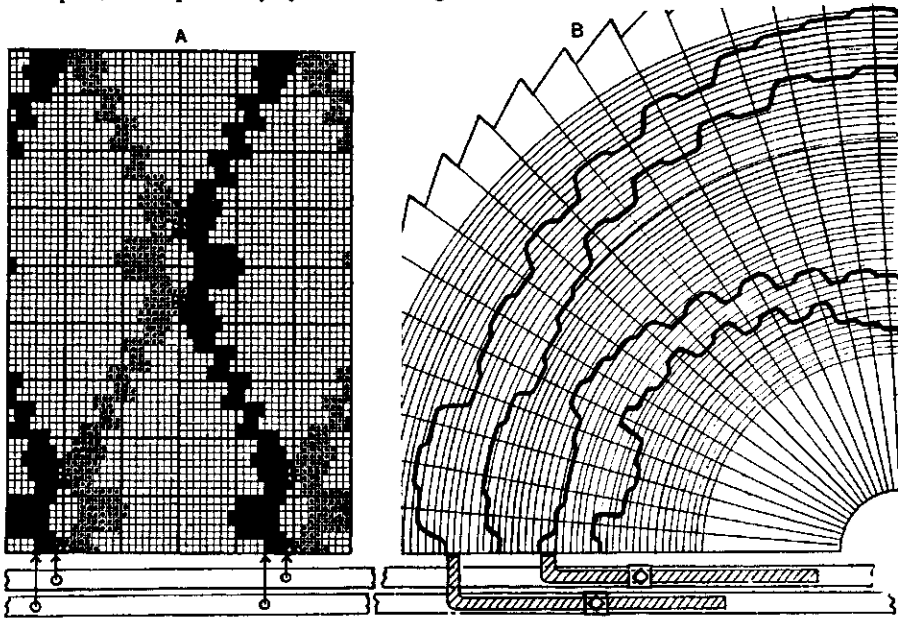


Figure A2.9

Although the traverses of the whip threads may require to overlap in the cloth, as in the example given in *Figure A2.8*, in the wheel it is necessary for some thickness of wood to separate the grooves at every point; therefore the relative position of the pecks is not the same as that of the needles in the bars. This is illustrated in the lower portion of *Figure A2.9* where the pecks are represented as being against the outer edges of the grooves, while the corresponding positions of the needles are indicated by the arrows at the completion of the first traverse to the left. The needles are only three spaces distant from each other, compared with 13 spaces from centre to centre of the pecks. When a new design is introduced, repeated adjustments are made by releasing the screws which secure the pecks and moving the shifter frames until the needles in the respective bars are in the correct relative position for producing the desired effect in conjunction with each other.

#### *Spacing the needles in the bars*

The correct spacing of the needles is of the greatest importance; and a method of marking the bars to show where the needles require to be driven in for the

design D is illustrated at E,F,G, and H in *Figure A2.10*. Only rather more than one repeat of the pattern is shown; but in practice, in order to reduce the liability of error, it is customary first to measure off, by means of a reed scale and dividers, the width of several repeats. The spaces are indicated on a bar over the desired width, and then each space is divided up into the required number of parts. If more than one needle bar is employed, in order to ensure that all are equally accurate the spacing of all the needles is marked as represented at E, on a separate piece of wood, termed a 'pattern stick,' which is rather longer than the width of the warp in the reed. The number of the bar is indicated against

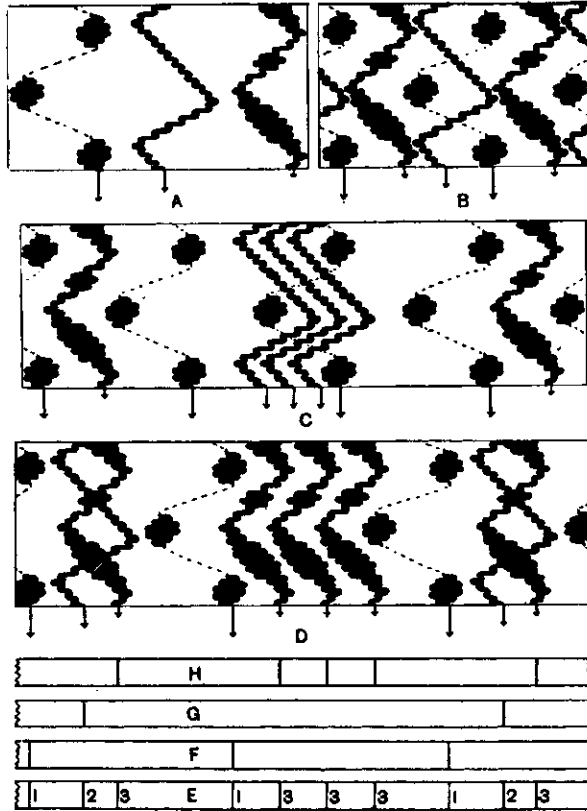


Figure A2.10

each mark upon E, and the piece of wood and the bars are placed together; then with the aid of a set-square the marks are indicated on the respective bars in turn, as shown at F, G and H. The punches used in driving in the needles are shaped so as to prevent the points from being damaged, and the lower end forms a projection which enables a needle to be driven in a vertical direction for the exact distance required, different punches being employed for the different lengths. After the needles have been driven in they are bent back, those in the rear bar being inclined until the points are directly above the edge of the bar, while those in the other bars are successively bent back a slightly greater distance.

Afterwards the spacing of the needles is again adjusted, but this time each bar is laid flat in a suitable position in relation to the pattern stick, and the needles are, if necessary, bent to right or to left until their points are in exactly the proper position.

### *The size of repeat*

The maximum number of picks in a design is usually between 320 and 350 but if required it can be doubled by turning the pattern wheel once in every four picks. However this method is not often used as it has the effect of making the figure coarser in outline. The width of repeat of a single motif is limited to 9 cm, i.e. the maximum throw that the tappets can give to a shifter bar. Due to the possibility, however, of varying the spacing of the needles on each bar there is, in effect, no limit to the width of repeat.

For example, assuming that three grooves are cut in a lappet wheel to produce the three systems of traversing shown at A in *Figure A2.10*, the designs given at B, C, and D, and many others, may be readily produced from the same wheel. The spacing of the needles is indicated below B, C and D, by the arrows, which are shown of different lengths to correspond with the positions of the respective bars. B shows an effect which can be formed by spacing the needles the same in each bar, one needle being required in each for every repeat. The shifter frames and pecks will, of course, require to be so adjusted that the all-over design will result by the three bars working in combination. C shows a change of effect due solely to varying the positions of the needles, the bars being in exactly the same relation to each other as in B. The change of effect from C to D, however, is due not only to a variation in the spacing of the needles, but in addition the relative position of the bars will require to be changed; while the example is also illustrative of a scheme of applying differently coloured threads.

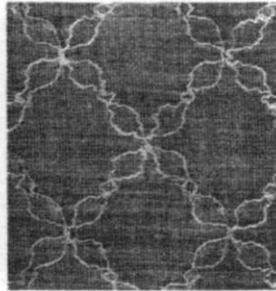
### *Presser wheel system*

The presser wheel system is different from the common wheel system in that the wheel is rotated one tooth at every pick, and a peck is made to press continuously against the outer edge of the groove, which is the only side of the groove that requires to be shaped according to the pattern. In keeping the pecks constantly in contact with the outer edges, the straps, S, in *Figure A2.2* and the treadles, T, are thrown out of action. On the underside of each shifter frame which is in use, and near the centre of the loom, a hook is inserted to which one end of a light spiral spring is attached. The other ends of the springs are connected to a bracket which is fastened below the slay and passes under the frames. The springs are in line with the shifter frames, and the tension tends to draw the latter in the direction away from the centre of the pattern wheel; hence, as the wheel turns, there is always a certain amount of friction between the pecks, and the outer edges of the grooves. In some cases, in order to reduce the friction, larger pecks—up to 10 mm diameter—are used; or, when very long moves are required, the bent end of a peck may consist of a specially shaped spindle upon which a small anti-friction bowl revolves where contact takes place with the outer edge. As a rule, however, the ordinary size and form of peck is found to

work quite satisfactorily, and is, therefore, most generally employed, as the use of a larger peck makes it necessary for the radial spaces and the pitch of the teeth to be greater, which increases the size of the wheel and restricts the length of the repeat. On account of a tooth being required for every pick, a presser wheel requires to be larger, and is more costly than a common wheel for the same number of picks in the repeat; nor can such long patterns be obtained. There is, however, greater scope for producing diversity of effect than with a common wheel. Patterns of a less massive or solid character may be formed, as in this case the return movement of a needle bar, on alternate picks, is not essential. Consecutive moves in the same direction can be made, and waved line effects be formed, each of which is of the same width as the thickness of a thread, as shown in *Figure A2.11*; or the whip threads may be used to form a fine outline to a simple figure, as is represented in *Figure A2.12*. The return movement of the needle bars may, however be readily arranged for, and variety

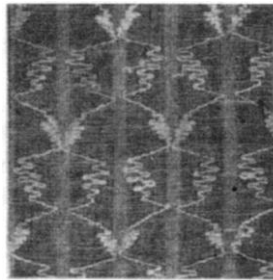


*Figure A2.11*



*Figure A2.12*

of pattern be obtained by combining solid figures with line effects, as shown in *Figure A2.13*. The traversing of the whip threads in *Figure A2.13* is shown in *Figure A2.14*, in which the vertical spaces represent the splits of the reed, and the horizontal lines the picks, the repeat extending over 24 splits and 62 picks.



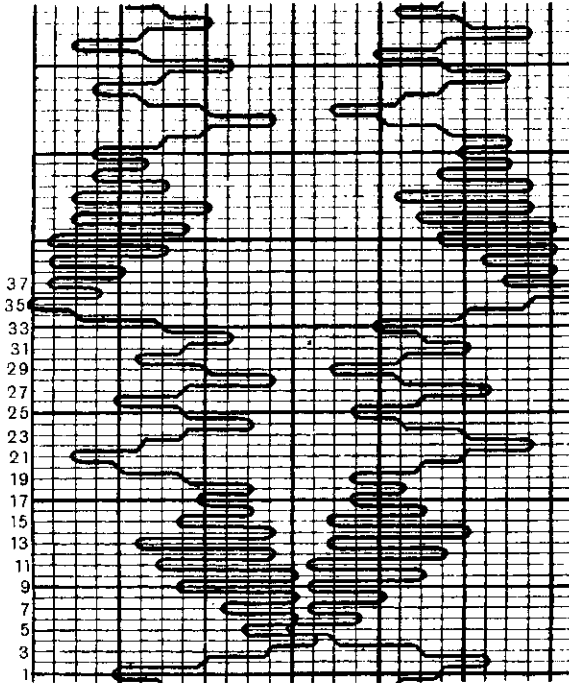
*Figure A2.13*

Two needle bars are required in forming the pattern, and the traverses overlap by one split, giving the design an all-over character.

#### *Construction of a presser wheel*

In constructing a presser wheel the concentric lines are marked according to the sett of the reed in the ordinary manner, but a radial line is drawn and a tooth

cut for every pick in the repeat. Thus, in *Figure A2.15*, in which the thick lines represent the shape of the grooves for producing the effect in the lower portion of *Figure A2.14*, the wheel, which is arranged for a left-hand loom, is divided into 62 radial spaces. The radial lines correspond with the horizontal lines (or picks) of the plan, and are numbered to coincide, while a concentric space corresponds with a vertical space. As a peck is constantly in contact with the outer edge of a groove, the shape of the inner edge is of little account so long as sufficient space is allowed between the edges for the free passage of the peck. Every movement of a thread requires to be marked on the outer edge.



*Figure A2.14*

Thus, on the horizontal line numbered 17 in *Figure A2.14*, the first thread is 8 spaces inward; therefore, on the corresponding radial line in *Figure A2.15*, the outer edge of the first groove is marked on the eighth concentric space. On the following horizontal lines the first thread is 10, 7, 4, 2, 5, 7, 10 etc., spaces inward in succession, and comparison will show that the outer edge of the groove is successively marked on the corresponding concentric spaces where the radial lines are intersected. The shape of the second groove is similarly indicated, care being taken in commencing that sufficient space will separate the grooves at every part.

As the wheel is turned one tooth at a time, the outer edge of each groove presses a peck to the right, or permits it to be drawn to the left, according to its shape. Between the radial lines it will be noted that the shape of the outer edge varies according to whether the movement of a peck is from or towards the centre of the wheel. Where the traverses are from the centre (to the left in this

case), the grooves are so shaped that the movement is almost instantaneous, the springs being allowed immediately to contract. On the other hand, where the traverses are towards the centre of the wheel, during which the springs are distended, the outer edges are gradually sloped, which prevents the wheel from

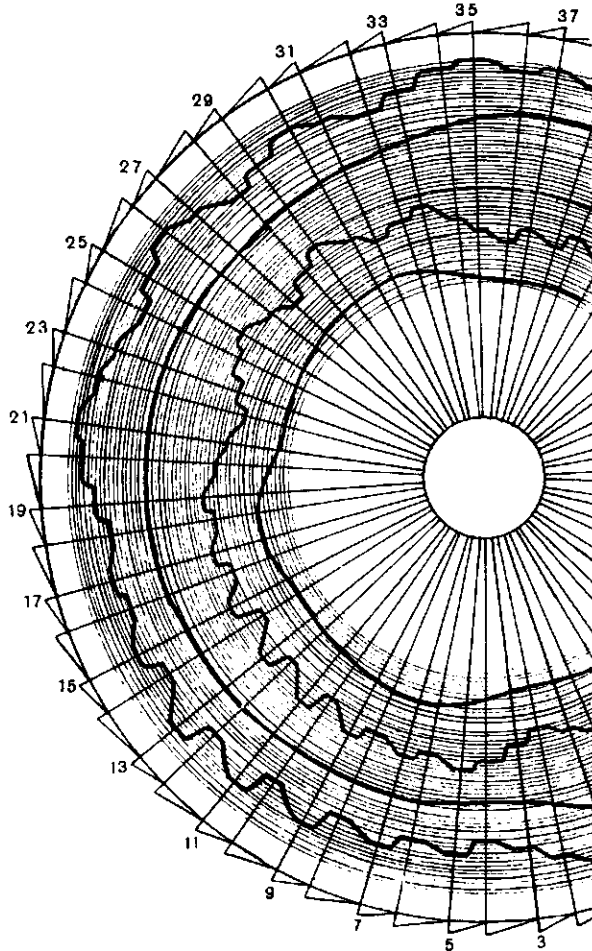


Figure A2.15

being locked, and at the same time reduces the friction with the pecks. A disadvantage which arises from the grooves being thus shaped is that a wheel cannot be used for the opposite hand of loom to that for which it has been cut, as, if rotated in the reverse direction, it will be locked by the pecks.

In producing designs which include portions of a figure in which a warp thread is repeatedly traversed to left and right alternately (as on the picks 4 to 18 and 35 to 49, in *Figure A2.14*), the spaces between the radial lines of the wheel are usually made alternately of different sizes in the proportion of about 3 to 2. This is illustrated in *Figure A2.15*, in which the odd-numbered teeth are shown smaller in pitch than the even teeth; and it will be noted that in the

solid portions of the figure the moves towards the centre of the wheel are arranged to coincide with the larger radial spaces. The friction with the picks is thus reduced when there is most strain, as a greater space gives more latitude for gradually sloping the outer edges of the grooves, and the engaging of a larger tooth provides more time for a movement. With the arrangement of different pitches of the teeth the two bowls, carried by the low shaft gear wheel, are of different sizes to correspond, the larger bowl lifting the turning catch high enough to engage the larger teeth, and the smaller bowl, the smaller teeth; but the leverage is so arranged that the small bowl is ineffective in operating a large tooth. If, therefore, the wheel gets an odd number of teeth out of proper rotation, it will remain stationary for a pick, and this gives the advantage that in the solid figure the to-and-fro movements of the needle bars are retained in correct time with the picking. It is, of course, only in the parts of a design where the traverses are alternately to left and right that each movement of a bar can be definitely arranged to correspond in direction with the pick that follows. In the other part of a pattern the direction of a traverse may or may not coincide with the direction of the following pick; and care is necessary here in arranging the moves, or undue friction may be caused. Thus, long moves may be more readily made if they correspond with the engaging of the larger teeth, and if each is in the same direction as the pick that follows.

#### *Length of whip warp*

Due to lateral displacement a whip thread requires to be very much longer than the ground warp. Assuming that the average length of the traverses of a whip end is 5 dents, and there are 10 dents per cm, 0.5 cm of whip warp will be required at every pick; and if 15 picks per cm are inserted,  $0.5 \times 15 = 7.5$  cm of whip warp will be required for each cm of ground warp. The following formula will provide an idea of the proportional lengths of the whip and ground warps:

$$\frac{\text{Total dents traversed in repeat} \times \text{picks per cm}}{\text{Picks in repeat} \times \text{dent per cm}} =$$

= number of times the whip warp is longer than the ground warp

In finding the total number of dents traversed by a thread it is necessary to note the moves in succession and add them together—as, for example, in *Figure A2.14* the first eight moves of the thread on the left are 4, 3, 2, 3, 2, 3, 3, 5 splits or dents, which, added together, total 25. By continuing in this manner it will be found that the number of splits traversed in the full repeat by the first thread = 206. The picks in the repeat = 62, and assuming that there are 10 splits and 15 picks per cm the calculation will be:

$$\frac{206 \text{ total splits} \times 15 \text{ picks per cm}}{62 \text{ picks in repeat} \times 10 \text{ splits per cm}} = 5 \text{ of whip warp to 1 of ground warp.}$$

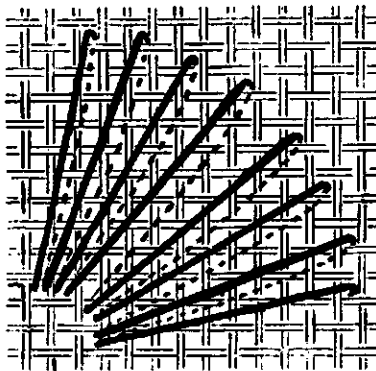
The calculation is more applicable to common wheel lappet designs than presser wheel styles, and only gives an approximate length of whip warp that is required, as the length can be varied by the tension that is put upon the whip threads.



## SWIVEL WEAVING

The term swivel is sometimes applied to the type of loom in which several narrow fabrics, such as hat-bands, ribbons, tapes, etc., are independently formed alongside each other. In this machine a separate shuttle is employed for each fabric, but there is no fly shuttle, and the goods are now generally described as smallwares. In broadloom swivel weaving, however, a number of small shuttles work in conjunction with an ordinary fly shuttle, the latter inserting a ground weft which forms with the warp a foundation cloth upon which the swivel shuttles produce figures in *extra weft*. The chief purpose of the swivel arrangement is to produce the ornament with the least possible waste of the extra yarn. Each figure, and in some cases each part of a figure, in a horizontal line of the cloth, is formed by a separate shuttle; the extra weft thus being introduced only where required, with little material extending between the figures on the reverse side of the cloth. In addition to the great saving of the figuring yarn, the swivel method has the advantage over the ordinary system of extra weft figuring that each shuttle may control a distinct colour, while the figures have a richer and fuller appearance on account of the weft being thrown more prominently on to the surface. The addition of the swivel mechanism, however, makes the loom much more complex, consequently there is reduced speed and output. The cloths are woven wrong side up, and there is, therefore, the disadvantage that defects caused by broken threads more readily escape observation; but, on the other hand, weaving the cloth right side up would necessitate the bulk of the warp being raised on the swivel picks. Compared with lappet figuring, in which the floats of a thread cannot be stitched between the extremities, swivel figuring produces much neater effects, as any form of weave development can be applied to a figure. Effects are readily produced that appear and handle very similarly to styles in which the pattern is formed after weaving by embroidery. A distinguishing feature of the embroidered designs, however, illustrated in *Figure A2.16*, is that the figuring threads may be inclined at any angle in the cloth. In swivel effects the figuring threads are always traversed parallel with the weft threads of the foundation cloth, and at right angles to the warp threads.

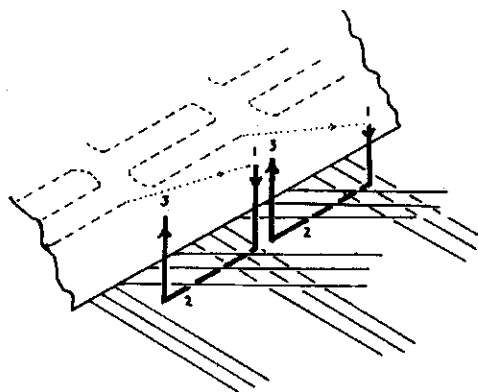
*Figure A2.16*



Despite some structural advantages, the swivel fabrics are produced at a very slow rate and have been superseded by similar constructions which can be more easily made on modern embroidery frames.

*Basic operations in swivel weaving*

The swivel wefts are wound on small bobbins which are placed in shuttles 4 to 7 cm in length. These shuttles are carried in a swivel frame attached to the sley. When ground weft picks are introduced from ordinary shuttles, the frame is kept above the ground warp with the swivel shuttles well clear of the top shed. After each ground pick a shed is formed for the swivel yarn. The frame is lowered and the raised ground ends fit into the recesses between the shuttle holders. The shuttle holders are, therefore, lowered into empty portions where all the ground ends have been left in the bottom shed line, as shown at 1 in *Figure A2.17*.



*Figure A2.17*

Whilst in this position the swivel shuttles are passed from one holder to another underneath the raised positions of the shed, leaving a trail of weft in their wake and this produces one figuring float (2, in *Figure A2.17*). Any interlacing can be easily formed in the middle of the float because some ends in the top shed line can be dropped without any interference with the passage of the small shuttles. Having in this way introduced the extra weft picks, the frame withdraws upwards (3, in *Figure A2.17*) a plain shed follows, and an ordinary pick of weft is inserted. The downward and upward movement of the frame constitutes the stitching sequence in this method of weaving. From this description two aspects should be clear:

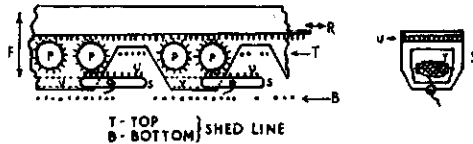
- (1) No ordinary picks of weft can be inserted whilst the swivel frame is down, and therefore the picking is of a pick-at-will type controlled from the jacquard.
- (2) Take-up must be of an intermittent type so that the cloth is not moved forward after the extra weft picks.

Two further points arising from the preceding description are that there must be a mechanism to control the downward movement of the frame, and another to control the passage of shuttles from holder to holder. Both mechanisms are jacquard controlled because there may be portions of the fabric where the figure is not required, such as in isolated spot designs. The frame

itself is permanently spring-loaded to remain up. When it is required down, a jacquard connection releases a tappet which operates against a treadle attached to the frame and this treadle forces the frame down, overcoming the effect of the spring. As soon as the shuttles complete their traverse the tappet is withdrawn and the frame returns to its customary position.

### *Swivel shuttle propulsion*

The shuttle traverse may be controlled by a variety of mechanisms, the rack-and-pinion arrangement shown in *Figure A2.18* being the simplest. A long rack, R, at the back extends through the full length of the frame, F, and its movement is controlled by levers operated from a jacquard. This rack is capable of rotating small pinions, P, in each shuttle holder. The pinions in turn operate against corresponding racks, U, at the back of the swivel shuttles, S. A pinion in one holder in full contact with the shuttle rack will cause the shuttle to move out of



*Figure A2.18*

its holder and to traverse into the next along the track, V. Just before the first pinion loses control of the shuttle, the pinion in the next holder catches it and pulls it through, so that the shuttle is always under positive control. In the next series of swivel picks, the rack is operated in the opposite direction and the shuttles return to their original holders, in this way laying the opposite traverse of weft. Other mechanisms, such as circular track and pusher rod, can also be employed to control shuttle movement, and though they offer the advantages of closer figure spacing they are not as easily adaptable for two-frame or three-frame work as the rack-and-pinion device. Two-frame or three-frame work is, in fact, a rarity because of the slow speed of the cloth production; even with single-frame work the effective speed of weaving is reduced to one-half of normal loom speed. With two and three frames, two out of three, or three out of four picks do not add to the length of cloth produced, and therefore the actual speed of weaving in a loom running normally at say, 140 picks per min is reduced to 47 and 35 ground picks per min, respectively. This is far too low to offer any serious price competition to ordinary jacquard figured extra-warp effects even though there is some wastage of material in the latter method, or to power embroidery effects.

### *Elements of swivel design*

The pitch of the shuttles should bear a definite relationship to the width of repeat that the jacquard will give; and there are three factors to take into account—viz., the pitch of the shuttles, the number of jacquard hooks tied up, and the number of harness cords per cm. For instance, a machine tied up to 600 hooks

with 30 harness cords per cm will give a repeat of 20 cm in the reed. Therefore, if there are two swivel shuttles to each repeat, the pitch will be 10 cm; if four shuttles 5 cm; and if five shuttles, 4 cm. Conversely, a given pitch of the shuttles will determine what sett of jacquard is suitable for a certain number of hooks tied up—e.g., if the pitch is 8 cm, 40 ends per cm are suitable for a 320 tie giving one swivel shuttle to the repeat, and 24 ends per cm for a 384 tie giving two swivel shuttles to the repeat. Again a given number of harness cords per cm will determine the number of hooks to tie up to a certain pitch of the shuttles. For example, with 40 harness cords per cm and shuttles with a 5 cm pitch, the number of hooks tied up may be 200, 400, 600, etc., according to the number of swivel shuttles required to each repeat.

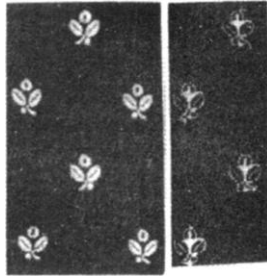


Figure A2.19

A typical swivel spot figure, on a plain foundation, is illustrated in *Figure A2.19*, the face side of the cloth being shown on the left, and the reverse side on the right. The squared paper design (on a reduced scale) is given at A in *Figure A2.20*; at B the face floats of the first figure are indicated with the swivel picks arranged alternately with the ground picks; while the corresponding interlacing diagram, shown at C, illustrates how a swivel thread is traversed in forming a figure. A complete spot is formed by one thread which is traversed alternately to right and to left on succeeding swivel picks; and as many swivel shuttles are employed as there are spots in a horizontal line of the cloth. Upon the completion of a line of spots, the swivel mechanism is thrown out of action until the commencement of the second line, when the carrying frame is situated so that the shuttles occupy the intermediate position, and the swivel threads are traversed again to right and to left in forming the figures which alternate with those in the first row. The mechanism is once more inoperative, until the shuttles are moved back to the original position in order to repeat the first line of figures; and, as shown by the dotted lines in A, *Figure A2.20*, a thread floats loosely on the reverse side of the cloth from one spot to another. The floating threads are afterwards cut away, and this is the only waste of the swivel weft that is made. It will be noted in A, *Figure A2.20*, that on the first and last picks of each figure the swivel weft is firmly interwoven. This is in order that the free ends of the threads will not be liable to fray out of the foundation. As the cloth is woven wrong side up, the marks of the plan A indicate warp, and are, therefore cut. A ground card is cut for each horizontal space in the full plan, hence there will be 64 ground and 50 figuring cards in the repeat of A, which will be arranged 1 ground card, 1 figuring card, for 25 times and 7 ground cards.

From the example given in *Figures A2.19* and *A2.20* it will be seen that each swivel shuttle can be employed to ornament the cloth over a certain area in a longitudinal line. In forming spot figures in which the width of the repeat is

equal to twice the pitch of the shuttles, it is necessary for all the shuttles in a frame to be traversed from one holder to another, but the weft is withdrawn only from those which are passed through a warp shed. In such a case an alternate arrangement of spots can be woven without the carrying frame being moved laterally, the odd shuttles forming one row of figures, and the even shuttles the figures that are intermediate.

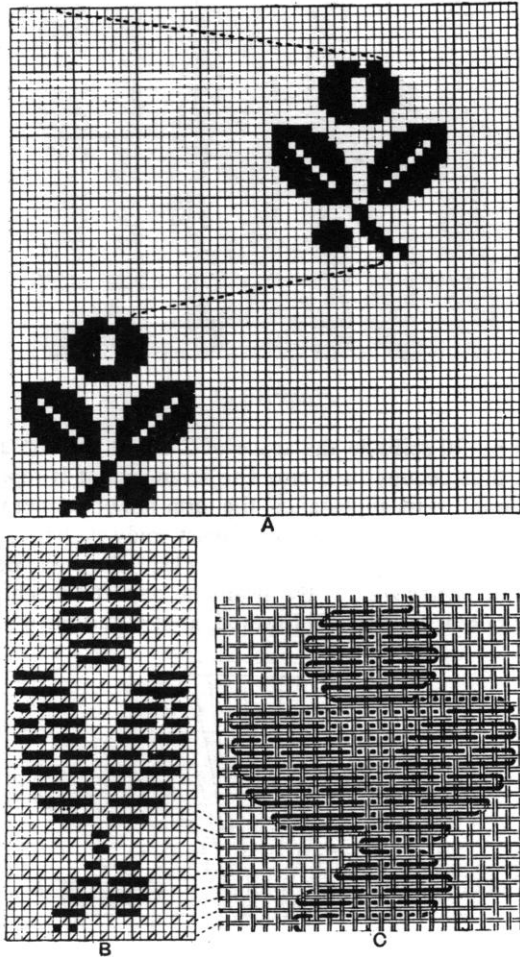
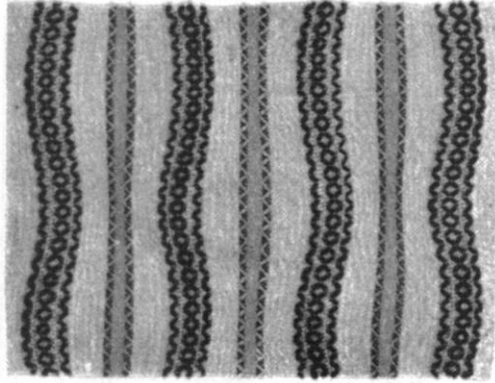


Figure A2.20

In addition to normal figuring it is possible to create full embroidery-type figures by racking the shuttles back to their original positions when they withdraw from the shed, in this way producing a backing float which adds to the solidity of construction. Other methods of embellishment consist of loading shuttles with weft of different colours and combining ground-cloth figure with swivel figure.

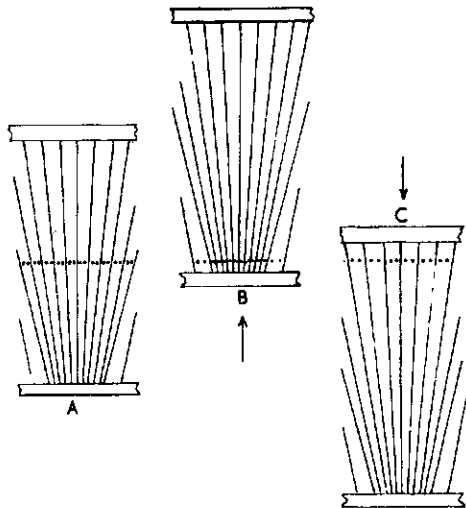
## ONDULE FABRICS

All or a portion of the ends are made to form wavy lines in the cloth, as shown in *Figure A2.21*, by means of a deep rising and falling reed in which the wires are not placed vertically, but are arranged at varying angles. For example, 30 splits of the reed may occupy a space 2 cm wide at the bottom and 4 cm wide at



*Figure A2.21*

the top, followed by 30 splits in the space of 2 cm at the top and 4 cm at the bottom, 60 splits thus occupying 6 cm. The arrangement is repeated across the width, and, on account of its appearance, the term fan or paquet is applied to the reed. The wires are at an equal distance apart midway between the top and bottom, and when the reed beats up in this place the ends are in the normal position, as at A in *Figure A2.22*. By means of a special mechanism, however, the reed is slowly raised, as at B, and lowered, as at C and the ends (except those



*Figure A2.22*

in the central splits) are gradually moved, some to the right and others to the left of their normal position, and then back again. An ogee shaped wave effect is formed, which usually extends over about 5 to 8 cm in length and width. All the warp is brought from one warp beam, so that additional strain is put on the ends which wave the most, while the straight ends in the centre contract more than they would under normal conditions.

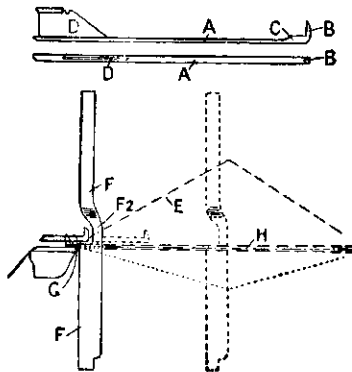
A modification of the above style is made that is not an ogee shaped effect, but all the ends wave uniformly in a vertical direction. A weft ondule effect, also, is sometimes made by arranging the warp in alternate sections (each, say, about 2 to 3 cm wide), under the control of two easing bars, by means of which the odd sections of ends are gradually tightened while the even sections are slowly slackened, and then *vice versa*. Where the warp is held tight the picks lie closer together than in the slack warp sections, hence the changes in the tension on the ends cause the picks to form a horizontal waved effect.

### WILTON PILE HOOK LOOM

In weaving wide, seamless Wilton pile carpets the transverse wire method of forming and cutting the pile limits the speed of the loom which, in proportion to the width of the woven fabric, also occupies a very large amount of floor space. The wire method of weaving is, therefore, neither so productive nor so economical as other systems of pile carpet manufacture. Wilton carpets, however, are very popular and the demand for wide seamless fabrics has led to the introduction of Wilton pile looms in which, in place of transverse wires, a series of hooks, placed longitudinally, is employed. There is one hook to each group of warp threads and to each split of the reed. The principle had been applied in different ways, and in the following the special features are described and illustrated of one hook and reed motion which enables wide Wilton carpets to be woven at a comparatively high speed.

In the upper portion of *Figure A2.23* a side elevation and a plan are given of a loop forming and cutting hook A, of which B shows the hooked end and C a

*Figure A2.23*



shank part which is slightly deeper than the body part that extends to the cutting knife D fixed on the hook A. The hooks are mounted above the carpet fell on the breast rail, and by means of positive cams fitted on the driving

shaft of the loom, the whole body of the hooks is given a reciprocating movement towards and from the reed. Also, by means of two racks between which they are mounted the hooks are tilted sideways. Instead of the usual kind of reed wire a special form of blade, F, illustrated in *Figures A2.23* and *A2.24*, is used in conjunction with the hooks.

The order of shedding is the same as in a three-shot, wire-woven Wilton pile, and the chain healds work opposite to each other in 3-and-3 order so that the picks are in groups of three. The chain ends are raised only to the central line, shown at H in *Figure A2.23*, and the shuttle passes the weft between this line and the bottom shed line. On the second pick of each group of three the stuffer heald raises the stuffer ends, and the comber-board the pile threads to the central line, and the comber-board is tilted so that the rear part is moved through a greater distance than the front in order to place all the warp threads in the same horizontal plane. The jacquard griffe is raised and lifts one pile thread E in each group to a higher level, as illustrated in *Figure A2.23*. As the reed moves back following the beating up of the second pick, the pile threads E are held in their normal position on the right of hooks A, which also are in their normal

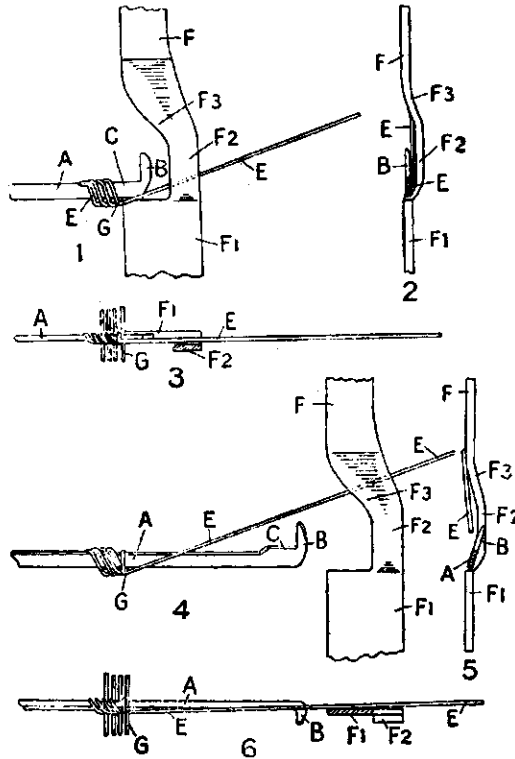


Figure A2.24

position, as shown in the enlarged diagrams given at Nos. 1, 2 and 3 in *Figure A2.24*.

No. 1 in *Figure A2.24* is a side elevation of a portion of a reed blade F and the end portion of a hook A with a pile thread E, and shows the respective



positions when a pick of weft G has been beaten up. No. 2 is a front view and No. 3 a plan of the parts represented in No. 1. Each reed blade F has a recess, the base of which is formed of part of a broader portion F1 that extends downwardly in its forward position the broad portion is in advance of the outer end of the hook A below the lower edge of which the weft G is beaten up. This position is represented also in *Figure A2.23*, and, as shown at No. 2. in *Figure A2.24*, each reed blade is bent sideways so that the portion at F2 forms a recess which receives the pile thread E that extends from the right side of hook A. The pile threads are always on the right side of the hooks A during the beating up of the weft.

As the jacquard griffe rises and lifts the selected pile threads the hooks and the reed are moved back to the position illustrated at No. 4 in *Figure A2.24*, and the dotted lines in *Figure A2.23* and the hooked end B of each hook moves to a position where it is lower than the pile thread E. Each pile thread, as it rises, is moved to the left by the pressure of the bent portion F3 of the blade F, and at the same time the hook A is tilted to the right so that the hooked end B passes beneath the pile thread E which is lowered so that it descends on the other side of hook A. This is illustrated at Nos. 5 and 6 in *Figure A2.24*, which show a front view and plan respectively of the parts represented at No. 4. Immediately the pile thread has descended into contact with the hook A the latter is oscillated and brought back into its vertical position, and the thread, as it continues to descend, is guided by the bent portion F2 of the neighbouring blade F under the hook A and passes to its initial or normal position in the bottom shed line. The third pick of a group of three is then inserted and beaten up to the position shown in *Figure A2.23* and No. 1 in *Figure A2.24*.

In looping a pile thread over a hook A it is folded over the shank part C which is deeper than the body part of the hook, and it is the part C which determines the length of the pile produced. As the picks are beaten up succeeding loops of pile are forced forward on to the narrower part of the hook A along which they advance readily because of having been formed over the deeper part at C. The loops then come into contact with the cutting edge of the knife D, *Figure A2.23*, which cuts the threads on the forward stroke of the hook and converts the loops into velvet pile.

Due to improvements in wire Wilton looms and the development of high speed broadloom weaving in the face-to-face system the hook loom is not likely to achieve a position of importance in the manufacture of Wilton carpets, particularly as it suffers from the disadvantages of constructional inflexibility and rigidity of pitch and pile height.

### CHENILLE AXMINSTER PILE

The distinctive features of chenille Axminster pile fabrics are: (1) A cut pile is produced without the aid of wires, (2) all the pile material is on the surface of a foundation cloth, (3) any number of colours can be employed. Two separate operations are required in producing the texture. In the first operation, which is termed 'weft weaving', the pile yarn in the form of weft, is interwoven with groups of warp threads that are placed some distance apart. This is followed by a process in which the fabric is converted into a number of long threads that form

the chenille pile, which in the second operation of weaving (termed setting) is inserted as weft in such a manner as to form the pile surface of a foundation texture.

The production rate is extremely slow and the process is highly specialised but it is capable of achieving the greatest density of pile of all the machine woven carpets. Due to very high labour costs involved it is used only to produce small quantities of the luxury class of carpets. Recently a process has been developed in which the pre-woven chenille weft can be set upon a hessian backing cloth by adhesion. Very high rate of production can be achieved but the resultant cloth lacks the rigidity and the stability of a texture in which the chenille weft is inserted at the same time at which the ground fabric is woven. In the adhesion setting no design, apart from broken colour or marl effects, is possible, because the chenille threads are not introduced singly but in multiples in the longitudinal direction.

In addition to carpets chenille threads are used to produce curtainings and table covers termed chenille velvet. In these structures no question of designing arises as they are usually made in self colour styles. The chenille thread is often constructed by a twisting process and is simply used as weft in a plain weave fabric in which the warp is very fine and, being woven in a low setting, is completely covered by the tufted weft. The tufts project from the yarn in all directions as opposed to carpet chenille yarns in which the tufts are made to assume a V formation.

### *Chenille pile designing*

The principle of designing is the same as in other pile textures in which the pattern is due to diversity of colour, the design being painted out exactly as it is required to appear when woven. On account of the means employed in producing the cloth it is of greater importance in this than in any other class of pile that the design be drafted on paper to the proper size, and for this reason a special quality of design paper is generally used.

A portion of a chenille Axminster design is illustrated in *Figure A2.25*, in which 16 different colours are represented by as many different marks. Each large square of the design paper, which represents 25 mm<sup>2</sup> is divided into 9 spaces vertically and 5 spaces horizontally, each vertical space corresponding to two picks of the weft which forms the chenille, and each horizontal space to one chenille thread. The design paper is thus ruled in the proportion of one-half the number of picks put in during the first weaving operation to the number of chenille threads inserted in the second weaving operation. Each small space of the design paper represents two pile tufts formed in the colour that the mark indicates.

The pitch of design paper shown in *Figure A2.25* is suitable for a texture in which the chenille threads are woven with 72 picks per 10 cm, and which contains 20 chenille threads per 10 cm, giving 14.4 tufts per cm<sup>2</sup>. The pitch varies greatly in different cloths, ranging from 104 picks per 10 cm in the chenille and 48 chenille threads per 10 cm (giving 50 tufts per cm<sup>2</sup>) to 32 picks per 10 cm in the chenille and 12 chenille threads per 10 cm (giving 3.8 tufts per

cm<sup>2</sup>). For the former each cm square of the design paper is divided into 13 x 12 spaces, and for the latter into 4 x 3 spaces.

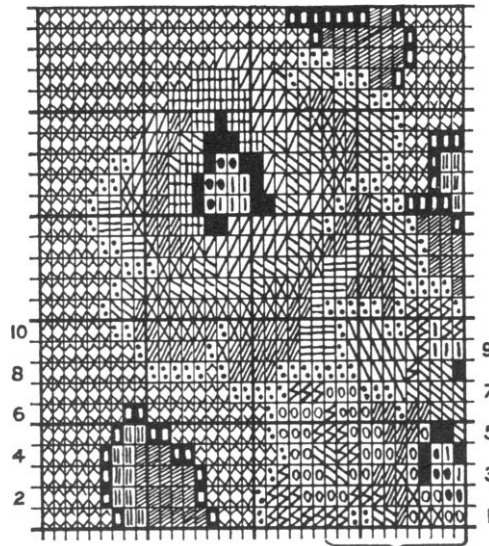


Figure A2.25

Although a design may repeat two or more times across the width, it must be extended to the full width of the texture to be woven. The horizontal spaces are numbered in consecutive order, the odd numbers on the right and the even numbers on the left, as shown in *Figure A2.25*.

#### *Formation of the chenille*

In weaving the chenille the design is turned so that the horizontal spaces are in line with the warp threads, and the cords or spaces are gone through in succession, beginning at the bottom and then at the top of succeeding cords, where the number is indicated. Two picks of the proper colour of weft are inserted to each horizontal space in a cord. This is illustrated in *Figure A2.26*, which shows the order of wefting to correspond with the bracketed portion of the first horizontal space of *Figure A2.25*, an enlarged plan of which is given on the left of *Figure A2.26*. The different colours are inserted in the order indicated in the design until the given longitudinal cord is completed, then a small space may be left without weft in order that in the setting the chenille thread will more readily turn at the sides of the cloth. Afterwards, the next longitudinal cord is gone through in the same manner, but in the opposite direction, and the process is continued until every cord in the repeat has been gone over.

The total length of chenille thread required to produce a design is equal to the length of a cord (originally a horizontal space) multiplied by the number of cords. Assuming that in the repeat of a design there are 120 chenille threads which are different from each other, and that 216 double weft picks are inserted

in weaving each chenille thread the width of the cloth, there will be  $120 \times 216 \times 2 = 51\,840$  picks inserted in producing the chenille for the full design. However, a large number of chenille threads may be woven alongside each other at the same time, so that one operation of chenille weaving enables very many repeats

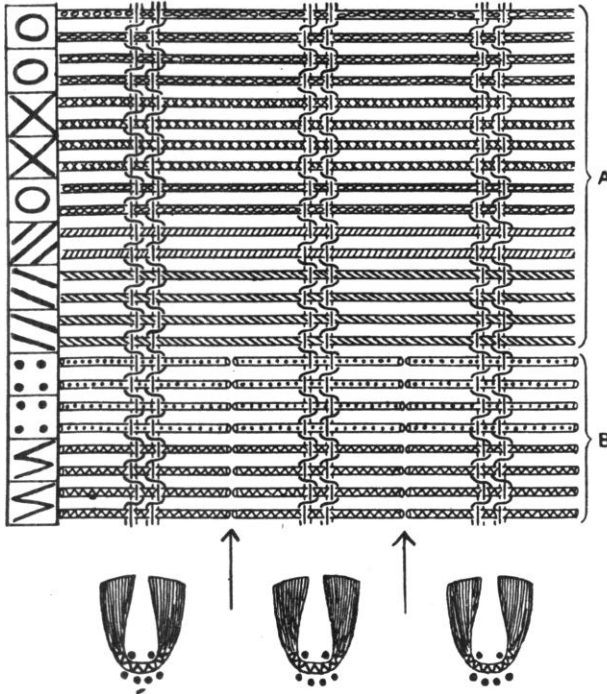


Figure A2.26

of the design to be obtained. Moreover, in the case of wheel designs and designs which are centred horizontally, it is only necessary to weave one-half of the chenille threads in the repeat in order to produce the full pattern.

The chenille is woven in a tappet loom which is fitted with a gauze mounting. The warp threads are arranged one end crossing two standard ends, and two groups of threads are reeded into consecutive splits of the reed with a space between them and the next two groups. Frequently, an ordinary form of reed is used, a number of splits being left empty between the groups of warp threads, but in some cases the reed contains splits only where the groups of threads are required to pass through. The space between the groups is varied according to the length of pile required, the pitch ranging from about 10 mm for a short pile to 25 mm and over for a very deep pile. The wefts are placed in a creel and fed through a drum-like selector with a capacity for 50 colours. Selected colour is proffered to a rigid rapier which inserts a double pick in a single insertion. At one time the colours were introduced by manual shuttle changes.

Figure A2.26 shows how the threads interlace, as viewed from the side that is underneath during the weaving of the chenille. A texture is produced across which the variously coloured picks of weft extend, being firmly bound in at

intervals by the gauze interlacing, as shown in the portion lettered A in *Figure A2.26*. The next process consists of cutting the picks in the centre of the space between the groups of gauze threads, as represented at B. This is followed by a process in which the strips are subjected to heat, moisture, and pressure, which causes each to assume the form of a thread in which the severed weft picks are V shaped as illustrated below B. The threads are then indicated by a letter or number, and each is wound separately in a convenient form for subsequent use.

All the chenille threads that are woven alongside each other (with the exception of the selvedge threads which are wasted), are, of course, exactly alike, and as many threads—within the capacity of the loom—are woven at the same time as will give the required number of repeats of the design. The count of the pile weft is usually equal to 300 to 400 tex worsted, and may be two, three or four-ply, but for a very deep coarse pile a yarn ranging from 800 to 1000 tex may be used. The gauze threads are generally cotton, and 60/3 tex or 48/4 tex may be used for the crossing threads, and 48/2 tex or 48/3 tex for the standard threads. For 100 m of chenille thread about 115 m of the standard threads and from 170 to 220 m of the crossing threads are required the lengths varying according to the thickness of the weft and the number of picks per cm.

### *Setting*

In this—the second weaving operation—the chenille pile thread, in which the differently coloured tufts are arranged in precise order according to the design, is traversed from side to side, and is bound in by means of a fine linen or cotton warp to the surface of a foundation texture. The length of each pile thread that is taken up at each horizontal traverse is equal to the width of a horizontal space of the design. The chenille thread is placed within an oblong metal case in such a manner that when it is withdrawn it is free from twists. The case is placed in a specially shaped shuttle, and the chenille is woven into the cloth in the same way as weft, except that the loom stops after the insertion of each pick of chenille while the weaver combs the thread forward and ‘sets’ it in the proper relative position to the preceding pick of chenille.

### *Structure of the fabric*

The structure of the ground varies according to the purpose of the fabric—table covers, hangings, etc., being made lighter and more flexible than carpets and rugs which require to be very stiff. D in *Figure A2.27* shows the weave plan, and E a cross-section through the weft of a structure in which there are two picks to each chenille thread—one ground end to two stuffer ends, and one fine binder end or catcher to every three ground ends. F and G similarly show a weave plan and a cross-section of a structure in which there are four picks to each chenille thread, one ground end to two stuffer ends and two fine catcher ends to six ground ends. Both structures may be woven with 36 ground ends, 72 stuffer ends, and 12 catcher ends per 10 cm, while for the first example 48 picks and 24 chenille threads per 10 cm are suitable, and for the second 64

picks and 16 chenille threads per 10 cm. The catcher or stitching ends unite the chenille pile threads to the foundation, as shown in the diagrams E and G.

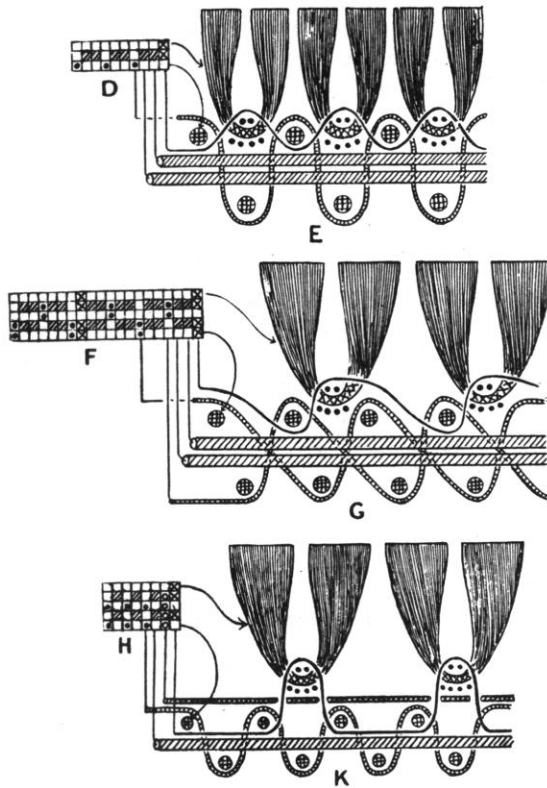


Figure A2.27

H and K in *Figure A2.27* illustrate another structure which is woven with four picks to each chenille thread. In this case the warp is arranged 1 ground end, 1 stuffer end for three times, 1 float end, and 1 fine catcher end. The float end is raised over all the picks of the foundation, but passes under the chenille thread, and the object of its insertion is to raise the chenille above the foundation and bring it more prominently to the face. In each example given in *Figure A2.27* only the fine catcher ends pass over the chenille pile threads.

#### WOVEN PILE FABRICS PRODUCED BY THERMAL SHRINKAGE

Useful and interesting pile constructions can be produced on normal fast running looms by utilising thermal shrinkage properties of certain synthetic materials. Some polyolefin and polyvinyl chloride/polyvinyl acetate copolymer yarns exhibit a marked tendency to shrink when subjected to the action of heat. A shrinkage of 50 to 30 per cent of the original length occurs at temperatures between 60°C to 100°C and the extent of contraction can be comparatively easily controlled either by the temperature gradient or by mechanical restraints

during finishing. If in a woven structure contractible yarns are suitably interwoven with other threads which do not contract then upon the shrinkage of one set of yarns an excess is created in the other set which is thrown into a pile formation.

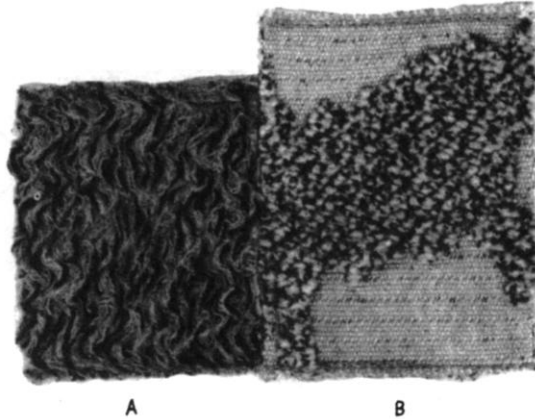


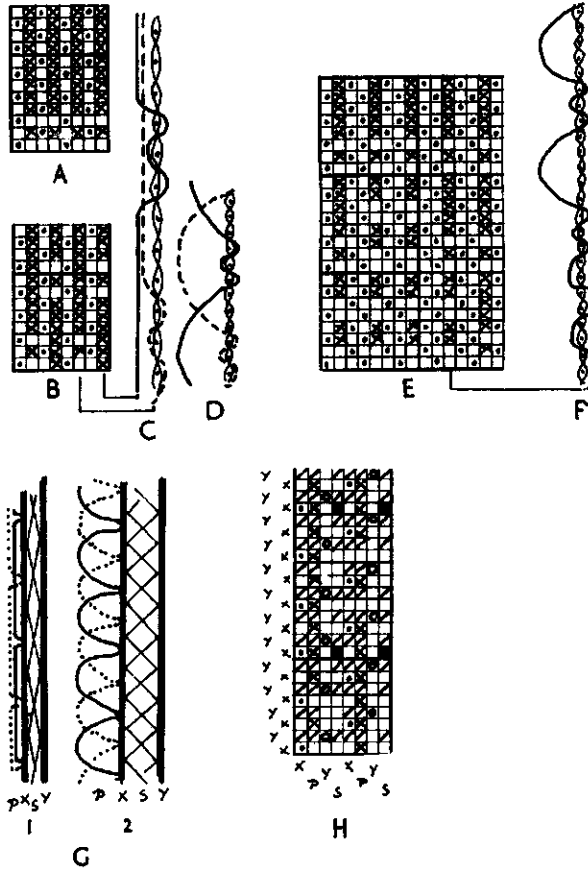
Figure A2.28

Two pile fabrics produced by the method described are shown in *Figure A2.28*. Fabric A is an all-over pile structure whilst B is a jacquard figured effect in which the pile figure is surrounded by bare ground. In the former, worsted pile yarn is used and the quality is suitable for an upholstery texture; in the latter a heavy wool and cotton blended yarn is employed for the pile in a construction of sufficient weight to serve as light rugs. The height of pile can be controlled by the degree of shrinkage achieved and by the float length, and the contractible pile threads can be used either as warp or as weft. It is preferable to use the special yarns in the warp direction as in this way the weft settings can be very low with a consequent rise in the rate of production of the cloth, the necessary consolidation being obtained on shrinking during the finishing operations. Also, when used as warp the pile effect can be magnified by tension differences between the shrinking and the shrink resistant yarn elements which are obtained by heavy weighting of the synthetic yarn beam and light weighting of the beam carrying the pile ends.

A in *Figure A2.29* shows a weave which after heat treatment results in a fabric with the appearance of a Brussels or uncut moquette structure obtained by the regimentation of the pile yarn binding marks in horizontal rows. The lifts of the contractible yarns are indicated by the dots and those of the pile ends by the crosses. It will be noted that the ratio of ends is 1:1 and that a fast pile binding order is used to secure good pile anchorage. At B a weave is shown in which the pile binding points are staggered which results in fuller surface cover. The same system of marking has been used as at A and the construction is represented by the weft sections at C and D which show the cloth appearance before and after shrinkage respectively. This structure corresponds to cloth A in *Figure A2.28*. At E in *Figure A2.29* a portion of a figured pile effect is given, one vertical row of which is represented by the weft section at F. In this cloth a shorter pile float is used and there are two contractible ends

to one pile end. The 2:1 ratio of ends may be necessary in heavier cloths to overcome the considerable structural resistance to shrinkage in such fabrics.

Using the thermal shrinkage technique a rich variety of structures can be produced and at G in *Figure A2.29* a schematic diagram is given which represents



*Figure A2.29*

a pile fabric with a built-in resilient underlay. Diagram 1 shows the construction before, and diagram 2, after heat treatment. The ground cloth, X, and the backing cloth, Y, both contain heat contractible warp threads. The two layers are joined together by loosely bound stitching ends, and the surface of the ground cloth is covered by floating pile ends, neither of which are contractible. Upon shrinking of the ground and backing cloths the surface floats form the pile whilst the stitching ends form the resilient underlay which is structurally incorporated in the fabric as shown in diagram 2. A full weave for this construction is given at H in which the dots represent the lifts of the ground ends; the circles, of the back ends; the crosses, of the pile ends; and the solid marks, of the stitching ends. The diagonal marks represent the separating lifts.

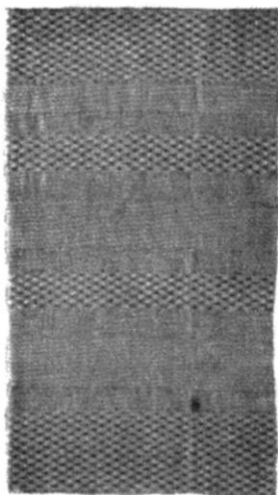
The use of heat contractible yarns is not confined to pile constructions—they can be advantageously employed to produce seersucker and crepon effects but



care must be taken to introduce them in such fabrics which do not require ironing. It will be appreciated that at temperatures of 150°C to 160°C the heat sensitive yarn elements are liable to melt.

### TUCK FABRICS

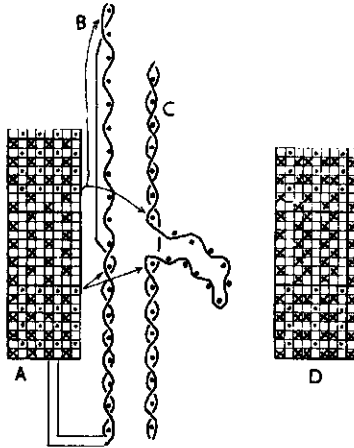
Tuck fabrics are constructions in which a permanent cloth fold or plisse is created during weaving. Fabrics of this type are used for skirtings, blouses and shirtings and are made in fine yarns and settings, cotton being the most common constituent of both warp and weft. The tucks may be of varying length from 5 to 10 mm; as each tuck is, in effect, a cloth fold, to produce one it is necessary to create an excess length of fabric which is twice that of the tuck itself and in a cloth woven with 30 picks per cm, between 30 to 60 picks are inserted into each plisse portion. The folds are almost invariably produced in plain weave and a small portion of the cloth which precedes and succeeds a tuck must also be constructed in a firm weave, such as plain or fine warp rib, otherwise gaps are liable to open on the back of the cloth due to insufficient cohesion. The portions of the cloth between the firmly bound areas can be constructed in any weave and the cloth in *Figure A2.30* shows a typical tuck structure with plain tucks of varying length, 2-and-1 rib portions prior to, and following each tuck and a simple waved pique weave in the middle.



*Figure A2.30*

The fabrics are made with two sets of warp yarns, the ground, which does not participate in the formation of the tuck portions but is woven in the intervening areas, and the tuck ends, which weave continuously. Only one kind of weft is necessary but in some cases extra weft figuring is employed and in the fabric shown in *Figure A2.30* wadding weft is used for the pique portions. The full weave for a simple plain weave tuck fabric is given at A in *Figure A2.31* in which the ground end lifts are indicated by the dots, and the tuck end lifts by the crosses. The two sets of ends weave plain with each other outwith the tuck but in the tuck portions the plain weave is formed by the tuck ends alone

whilst the ground ends float underneath. The section B represents the appearance of the cloth just prior to the formation of the tuck whilst C shows the same cloth just after the fold has been completed. For the sake of simplicity considerably fewer picks are shown in the tuck than is usually the case in an actual cloth. D in *Figure A2.31* indicates a rib ground tuck in which the warp



*Figure A2.31*

is conveniently arranged: 2 tuck ends to 1 ground end. The section C shows that a tuck is created by forcing the ground picks which follow the tuck right up to the picks which precede it along the floating ground ends. The excess cloth represented by the tuck area folds over and is permanently bound in this form into the fabric. To produce good plisse fabrics two main conditions must be observed:

- (1) The ground warp must be heavily tensioned and the tuck warp comparatively slack
- (2) The ground picks just prior to, and just following the tuck portion must be in the same shed.

At one time to create a tuck the loom was stopped after the insertion of the first ground pick following the tuck area with the reed fully forward, the cloth was released and the warp pulled back until the last and the first ground picks were forced together. At present possibilities exist which permit the operation to be performed without stoppages. One of the methods involves the use of an additional cloth tension bar between the take-up and the cloth rollers. When it is required to form a tuck the tension bar is released by dobby control thus providing an excess cloth length. Simultaneously, the back rest, over which the ground warp runs and which is heavily springloaded, pulls back the excess of ground warp. Thus, the first ground pick following the tuck is beaten up to the ground pick which precedes the tuck and the tuck portion representing the excess cloth length puckers up. In another method use is made of a broken-back connecting arm to the sley. At the commencement of the tuck the forward movement of the sley is progressively shortened until sufficient length is created

whereupon the broken-back is straightened giving a full length beat-up which pushes up the excess cloth created into a pucker and joins the first pick which follows the tuck to the pick which precedes it.

# Index

- Alhambra quilts, 15
  - traditional mounting for, 372
- Astrakhan, imitation, 295
- Axminster pile carpets, 349, 419
  - chenille (*see* chenille)
  - gripper, 360
  - gripper, selection of pile, 362
  - gripper, tuft insertion, 364
  - spool, loom operation, 355
  - spool presentation, 354
  - spool setting, 352
  - spool, tuft insertion, 358
  - spool-gripper, 366
- Backed cloths, figured, 55
  - interchanging, 55
  - interchanging treble wefted, 58
- Backed cloths, imitation, 61
- Backed cloths, warp, 49
  - beaming and drafting, 51
  - methods of backing standard weaves, 52
  - methods of selecting ties for, 53
  - reversible, 50
- Backed cloths, weft, 44
  - interchanging figured, 55
  - methods of backing, 45
  - reversible, 44
  - with warp face weaves, 47
- Backed cloths, with wadding threads, 59
- Bannister or split harness, 375
- Belting structures (*see* multi-ply structures)
- Book muslin fabrics, figured, 73
  - ground weave variation, 79
  - method of designing, 76
  - settings of, 79
  - structure of, 74
  - traditional mounting for, 372
- Bottom and top douping (*see* leno fabrics)
- Bottom boards, 345
- Boucle or cord pile (*see* Brussels)
- Brocades, compound, 89, 94, 101
  - figured warp rib, 89
  - figured warp rib, ornamentation, 93
  - figured warp rib, traditional mounting, 372
  - figured warp rib, two-colour, 91
  - multi-warp, 101
  - multi-weft, 94
  - multi-weft, ground weaves, 96
  - multi-weft, reversible, 98
  - multi-weft, three-weft, 99
  - multi-weft, two-weft, 94
  - multi-weft, weave shading, 97
- Brussels (boucle, cord) pile carpets, 296, 306
  - multi-frame, 306
  - self-colour, 296
  - tapestry Brussels, 298
- Card cutting, computerised, 9
  - systems, 6
- Card repeating, 9
- Centre stitched double cloths, 131
  - centre warp stitching, 132
  - centre weft stitching, 135
- Chenille Axminster pile, 419
  - designing, 420
  - formation of chenille yarn, 421
  - setting, 423
  - structure of the fabric, 423
- Chintzing, 34
- Cloque or crepon fabrics, 180
- Comber-boards, sectional, 379
  - working, 300, 311, 314, 385
- Combined warp and weft tapestry (*see* tapestry structures)
- Compensating rods, 324
  - (*see also* easers)
- Compound brocades (*see* brocades)
- Conveyor belting (*see* multi-ply structures)
- Cord pile fabrics (*see* Brussels)
- Cordage jacquard, 314

- Corded velveteen (corduroy), 268  
 Crepon or cloque fabrics, 180  
 Cut effects in double cloths, 153  
   by the use of cutting threads, 156  
   by yarn interchange, 154  
 Cutting and looping wires, 287
- Damasks, 83  
   bannister or split harness, 375  
   card saving, 86  
   diversification of effect, 88  
   self-twilling jacquard, 84
- Decked mail eyes, 15, 16
- Designing (see jacquard designing)
- Double cloths, classification of, 103
- Double cloths, figured, 173  
   by combination of fine and coarse fabrics, 176  
   cloque effects, 180  
   combined with float on single cloth ground, 182  
   combined with warp and weft float, 177  
   simple interchanging, 174  
   with extra threads for wadding or figuring, 184
- Double cloths, centre stitched, 131  
   centre warp stitching, 132  
   centre weft stitching, 135
- Double cloths, interchanging, 136  
   cut effects due to cutting threads, 156  
   cut effects due to yarn interchange, 154  
   cut effects in, 153  
   double plain continuously coloured, 137  
   double plain in three or four colours, 147  
   double plain with changeable colour order, 142  
   double twill and sateen, 152
- Double cloths, self-stitched  
   beaming and drafting, 117  
   construction of designs, 108, 113  
   relative proportions of face and back threads, 106  
   reversible, 116  
   selection of face and back weaves, 107  
   selection of stitching positions, 120  
   tying or stitching, 107  
   warp wadded, 131  
   weft wadded, 129
- Double shuttle weaving (see face-to-face pile)
- Double sided pile (see terry pile and warp pile)
- Doup healds (see leno fabrics)
- Easers or slackeners, 231, 232, 238, 245, 389
- Extra thread figuring, 11  
   comparison of methods, 13  
   disposal of surplus, 12  
   imitation, 39  
   methods of introducing, 12  
   principles of, 11
- Extra warp figuring, 13  
   Alhambra quilts (see Alhambra)  
   binding between face floats, 17  
   continuous in one extra, 14  
   intermittent in one extra, 17  
   planting, 23  
   stitching by special picks, 23  
   with two extra warps, 20
- Extra warp and extra weft figuring, 36  
   spot effects, 37
- Extra weft figuring, 25  
   chintzing, 34  
   clipped spot effects, 29  
   continuous in one extra, 25  
   ground weave modification, 33  
   intermittent in one extra, 30  
   stitching by special ends, 33  
   with two extra wefts, 34
- Eyed doup needles, 211
- Fan or paquet reed (see ondule fabrics)
- Fancy toilet cloths (see figured piques)
- Figured piques, 65  
   classification of, 65  
   fast back, 68  
   five-and-six-pick structures, 71  
   four-pick structure, 71  
   half-fast back, 67  
   loose back, 67  
   method of designing, 68  
   traditional mounting for, 387
- Figured warp rib brocades (see brocades)
- Flat steel doups, 211, 221, 228
- Gauze (see leno structures)
- Gauze ground (see Madras muslin)
- Ghiordes or Turkish knot, 349
- Gripper Axminster (see Axminster)
- Hairline effects in double cloths, 137, 142, 147
- Hand-knotted carpets, 349
- Hand-woven tapestry, 190
- Harness mountings, traditional, 371
- Healds and harness mountings, 371
- Healds for face-to-face pile weaving, 321
- Imitation backed cloths, 61
- Imitation embroidery by swivel weaving, 415
- Imitation extra thread effects, 39

- Imitation fur, 295
- Interchanging double cloths (*see* double cloths)
- Inverted hook jacquards, 242, 316, 383
- Inverted key-holes in cordage jacquard, 315
- Jacquard, bannister or split harness, 375
- card-cutting systems for, 6, 9
  - cordage, 314
  - for face-to-face pile fabrics, 345
  - for leno structures, 240, 242
  - for pile fabrics, 301, 311
  - gripper Axminster, 363
  - heald and harness mounting, 371
  - inverted book, 242, 316, 383
  - sectional harness, 379
  - self-twillling, 84
  - traditional mountings, 371
  - with working comber-boards, 301, 311, 314, 385
- Jacquard designing, 1
- simplified and condensed, 3
- Knotted carpets, 349
- Ghiordes or Turkish knot, 350
  - Sehna or Persian knot, 350
- Lappet weaving, 393
- auxiliary mechanisms, 396
  - common wheel construction, 401
  - figuring movement, 394
  - length of whip thread, 410
  - multi-frame designs, 403
  - presser wheel construction, 407
  - presser wheel system, 406
  - representation of designs, 399
  - shifter bar movement, relation of, 397
  - size of repeat, 406
  - spacing of needles, 404
  - stitching movement, 395
- Leno (and gauze) structures, 207
- basic sheds of, 209
  - double slotted flat steel doups, 228
  - easers, 231, 232, 238, 245
  - equalisation of tension in, 230
  - eyed flat steel doups, 211
  - methods of producing, 211
  - negative easing action, 231
  - point draft or counter, 214, 226
  - positive easing action, 232
  - principle of, 208
  - Russian cords, 217
  - shaker device, 234
  - simple figured effects, 224
  - simple net, 217
  - simultaneous top and bottom douping, 219
  - slider frame and needle device, 255
  - slotted flat steel doups, 221
  - special lifts of standard ends, 216
  - with more than one assembly, 214
  - with two crossing ends per slot, 225
- Leno structures, jacquard, 235
- easer action in, 238, 240
  - marquiesette styles, 237
  - one-crossing-one styles, 236
  - one-crossing-two styles, 237
  - special mountings for, 240, 242
  - two-crossing-two styles, 241
- Leno structures on string doups, 388
- bottom and top douping, 388
  - drafting, 389
  - lifting plans for, 392
  - relative position of healds, 390
  - sheds formed in, 390
- Loop pile (*see* terry and warp pile)
- Loose-back piques, 67
- Madras muslin (gauze) structures, 244
- chintzed designs in, 250
  - designing, 248
  - double cover structures, 251
  - gauze and tug reed operation, 246
  - loom mechanisms for, 245
  - structure of, 244
  - tape-up motion, 248
  - with weft pile figure, 253
- Mitcheline quilts (*see* patent satin)
- Moquettes (*see* warp pile fabrics)
- Multi-layer fabrics, 158
- Multi-ply belting structures, 168
- Multi-warp brocades (*see* brocades)
- Multi-weft brocades (*see* brocades)
- Muslins (*see* book and Madras muslin)
- Net leno, simple, 217
- Ondule fabrics, 416
- reed, 416
- Pacquet or fan reed (*see* ondule reed)
- Patent satin structure, 80
- method of designing, 81
  - traditional mounting for, 385
- Pile fabrics (*see* terry, warp and weft pile)
- Pile fabrics produced by thermal shrinkage, 424
- Planting, 23, 310
- Plush (*see* warp and weft pile)
- Presser wheel (*see* lappet)
- Repp stitched weft tapestries (*see* tapestry)

- Reversible double cloths, 116, 175  
   multi-weft brocade, 98  
   tapestry structures, 198  
   treble cloths, 188  
   warp-backed fabrics, 50  
   warp-pile fabrics, 293  
   weft-backed fabrics, 44, 55, 58  
   weft-pile fabrics, 268  
 Rib, figured warp (*see* brocade)  
 Russian cords, 217
- Scotch lappet wheel loom, 394  
 Sectional jacquard and harness, 379  
   connection of hooks and needles, 380  
   designing and card cutting for, 381  
   draft of the warp threads, 381  
   harness ties, 379  
 Sehna or Persian knot, 350  
 Self-stitched double cloths (*see* double cloths)  
 Self-twilling jacquard, 84  
 Selvedge shuttles, 357  
 Shaft monture (*see* bannister harness)  
 Shaker or jumper motion, 234  
 Slackener (*see* easer)  
 Slotted steel doups, 221, 228  
 Spool Axminster (*see* Axminster)  
 Spool-gripper Axminster (*see* Axminster)  
 Stitched double cloths (*see* double cloths)  
 Stitched figuring weft constructions, 73  
 Swivel weaving, 411  
   basic operations in, 412  
   elements of design, 413  
   imitation embroidery, 415  
   shuttle propulsion, 413
- Tapestry Brussels carpets (*see* Brussels)  
 Tapestry structures, 190  
   combined warp and weft, 202  
   hand woven, 190  
   heald and harness mounting for, 374  
   lifting rod and heald mounting, 378  
   repp stitched weft face, 200  
   reversible, 198  
   simple weft face, 192  
   three-and four-weft, 195  
   two-weft, 193  
 Terry pile structures, 274  
   cut pile fabrics, 285  
   figured fabrics, 283  
   formation of pile, 274  
   inverted hook jacquard for, 383  
   mixed colour effects, 285  
   ornamentation, 280  
   special mechanisms for, 279  
   stripe and check patterns, 281  
   terry weaves, 276  
 Toilet cloths (*see* figured piques)
- Top and bottom douping (*see* leno structures)  
 Treble cloths, 158  
   beaming and drafting, 163  
   figured interchanging, 186  
   methods of stitching, 161  
   systematic construction of, 158  
   use of centre layer as wadding, 168  
   with dissimilar weaves, 163  
   (*see also* multi-ply belting)  
 Treble-wafted reversible backed cloths, 58  
 Tuck fabrics, 427  
 Turkish towelling (*see* terry pile)
- Velvet (*see* warp pile)  
 Velvetreen (*see* weft pile)
- Wadding, in backed cloths, 58, 59  
   in double cloths, 129, 131, 184  
   in figured piques, 67  
 Warp-backed cloths (*see* backed cloths)  
 Warp pile, face-to-face, 320  
   all-over (continuous) pile, 325  
   carpet structures, multi-frame, 343  
   carpet structures, self-coloured, 333  
   continuous pile structures, 325  
   fast pile structures, 330  
   figured pile structures, 334  
   jacquard figured constructions, 341  
   jacquard, special, 345  
   moquettes, 325  
   special mechanisms for, 322  
   use of duplicate pile threads, 335  
   velvet structures, 327  
   Wilton carpet structures, 343, 344, 347  
 Warp pile, formed over wires, 287  
   all-over (continuous) pile, 289  
   all the pile over each wire, 290  
   alternate pile over alternate wires, 292  
   Astrakhan, imitation, 295  
   Brussels (boucle, cord) carpets (*see* Brussels)  
   card cutting for, 313  
   continuous pile carpets, 296  
   continuous pile structures, 289  
   cordage jacquard, 314  
   fast pile, 291  
   figured, multi-frame, 305  
   figured with one series of threads, 299  
   jacquard, special action, 301  
   loop and cut pile figure, 303  
   loop and cut pile on bare ground, 304  
   method of designing, 310  
   methods of weft insertion, 319  
   moquettes, 308  
   ornamentation, 294  
   pile figure on bare ground, 300  
   planting, 310

- Warp pile, formed over wires (Cont.)**  
reversible pile structures, 293  
settings, 293  
stripe and check effects, 295  
system of jacquard mounting, 311  
textural variety in, 316  
treble shed formation, 318  
uncut moquettes, 308  
velvet, 290  
Wilton carpets (*see* Wilton)
- Weft-backed cloths (*see* backed cloths)**
- Weft pile fabrics, 257**  
all-over (plain) velveteens, 258  
changing pile density, 261  
corded velveteens (corduroys), 268  
cutting of all-over velveteens, 266  
cutting of corded velveteens, 270  
density of pile, 261  
fast pile structures, 264  
figured cords, 273  
figured velveteens, 271  
length of pile, 260  
plain back velveteens, 258  
plushes, 267
- Weft pile fabrics (Cont.)**  
qualities of all-over velveteens, 266  
qualities of corded velveteens, 270  
reversible plushes, 268  
simplification of cutting, designs for, 265  
twill back velveteens, 265
- Wilton pile carpets, face-to-face, 333, 342**  
card cutting for, 346  
jacquard mounting for, 345  
multi-frame, 342, 344, 346  
self-colour, 296  
working bottom boards, 345
- Wilton pile carpets, formed over wires, 296, 306**  
card cutting for, 313  
cordage jaquard, 314  
designing for, 310  
loom mounting for, 311  
methods of weft insertion, 319  
multi-frame, 306  
planting, 310  
self-colour, 296
- Wilton pile carpets, hook loom, 417**
- Working comber-boards, 300, 311, 314, 385**