

Riveted Joints

1. Introduction.
2. Methods of Riveting.
3. Material of Rivets.
4. Essential Qualities of a Rivet.
5. Manufacture of Rivets.
6. Types of Rivet Heads.
7. Types of Riveted Joints.
8. Lap Joint.
9. Butt Joint.
10. Important Terms Used in Riveted Joints.
11. Caulking and Fullering.
12. Failures of a Riveted Joint.
13. Strength of a Riveted Joint.
14. Efficiency of a Riveted Joint.
15. Design of Boiler Joints.
16. Assumptions in Designing Boiler Joints.
17. Design of Longitudinal Butt Joint for a Boiler.
18. Design of Circumferential Lap Joint for a Boiler.
19. Recommended Joints for Pressure Vessels.
20. Riveted Joint for Structural Use—Joints of Uniform Strength (Lozenge Joint).
21. Eccentric Loaded Riveted Joint.



9.1 Introduction

A rivet is a short cylindrical bar with a head integral to it. The cylindrical portion of the rivet is called *shank* or *body* and lower portion of shank is known as *tail*, as shown in Fig. 9.1. The rivets are used to make permanent fastening between the plates such as in structural work, ship building, bridges, tanks and boiler shells. The riveted joints are widely used for joining light metals.

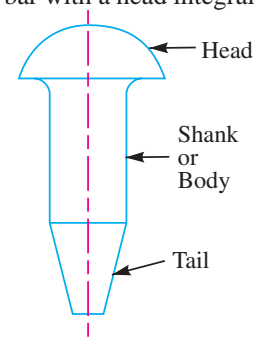

Fig. 9.1. Rivet parts.

The fastenings (*i.e.* joints) may be classified into the following two groups :

1. Permanent fastenings, and
2. Temporary or detachable fastenings.

The *permanent fastenings* are those fastenings which can not be disassembled without destroying the connecting components. The examples of permanent fastenings in order of strength are soldered, brazed, welded and riveted joints.

The *temporary or detachable fastenings* are those fastenings which can be disassembled without destroying the connecting components. The examples of temporary fastenings are screwed, keys, cotters, pins and splined joints.

9.2 Methods of Riveting

The function of rivets in a joint is to make a connection that has strength and tightness. The strength is necessary to prevent failure of the joint. The tightness is necessary in order to contribute to strength and to prevent leakage as in a boiler or in a ship hull.

When two plates are to be fastened together by a rivet as shown in Fig. 9.2 (a), the holes in the plates are punched and reamed or drilled. Punching is the cheapest method and is used for relatively thin plates and in structural work. Since punching injures the material around the hole, therefore drilling is used in most pressure-vessel work. In structural and pressure vessel riveting, the diameter of the rivet hole is usually 1.5 mm larger than the nominal diameter of the rivet.

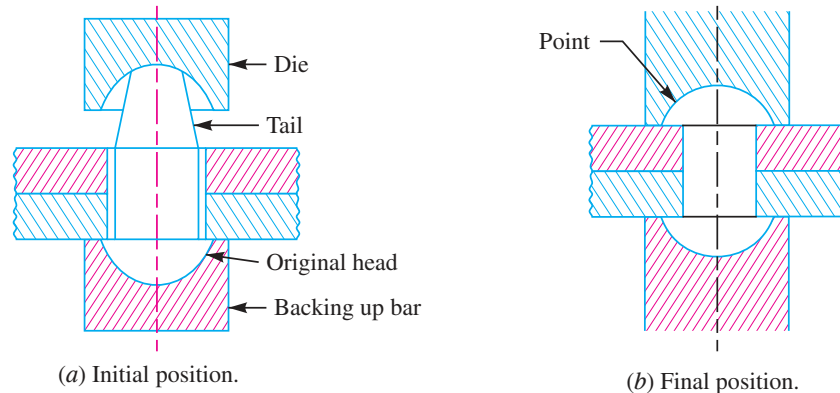

Fig. 9.2. Methods of riveting.

The plates are drilled together and then separated to remove any burrs or chips so as to have a tight flush joint between the plates. A cold rivet or a red hot rivet is introduced into the plates and the *point* (i.e. second head) is then formed. When a cold rivet is used, the process is known as *cold riveting* and when a hot rivet is used, the process is known as *hot riveting*. The cold riveting process is used for structural joints while hot riveting is used to make leak proof joints.



A ship's body is a combination of riveted, screwed and welded joints.

The riveting may be done by hand or by a riveting machine. In hand riveting, the original rivet head is backed up by a hammer or heavy bar and then the die or set, as shown in Fig. 9.2 (a), is placed against the end to be headed and the blows are applied by a hammer. This causes the shank to expand thus filling the hole and the tail is converted into a *point* as shown in Fig. 9.2 (b). As the rivet cools, it tends to contract. The lateral contraction will be slight, but there will be a longitudinal tension introduced in the rivet which holds the plates firmly together.

In machine riveting, the die is a part of the hammer which is operated by air, hydraulic or steam pressure.

Notes : 1. For steel rivets upto 12 mm diameter, the cold riveting process may be used while for larger diameter rivets, hot riveting process is used.

2. In case of long rivets, only the tail is heated and not the whole shank.

9.3 Material of Rivets

The material of the rivets must be tough and ductile. They are usually made of steel (low carbon steel or nickel steel), brass, aluminium or copper, but when strength and a fluid tight joint is the main consideration, then the steel rivets are used.

The rivets for general purposes shall be manufactured from steel conforming to the following Indian Standards :

- (a) IS : 1148–1982 (Reaffirmed 1992) – Specification for hot rolled rivet bars (up to 40 mm diameter) for structural purposes; or
- (b) IS : 1149–1982 (Reaffirmed 1992) – Specification for high tensile steel rivet bars for structural purposes.

The rivets for boiler work shall be manufactured from material conforming to IS : 1990 – 1973 (Reaffirmed 1992) – Specification for steel rivets and stay bars for boilers.

Note : The steel for boiler construction should conform to IS : 2100 – 1970 (Reaffirmed 1992) – Specification for steel billets, bars and sections for boilers.

9.4 Essential Qualities of a Rivet

According to Indian standard, IS : 2998 – 1982 (Reaffirmed 1992), the material of a rivet must have a tensile strength not less than 40 N/mm^2 and elongation not less than 26 percent. The material must be of such quality that when in cold condition, the shank shall be bent on itself through 180° without cracking and after being heated to 650°C and quenched, it must pass the same test. The rivet when hot must flatten without cracking to a diameter 2.5 times the diameter of shank.

9.5 Manufacture of Rivets

According to Indian standard specifications, the rivets may be made either by cold heading or by hot forging. If rivets are made by the cold heading process, they shall subsequently be adequately heat treated so that the stresses set up in the cold heading process are eliminated. If they are made by hot forging process, care shall be taken to see that the finished rivets cool gradually.

9.6 Types of Rivet Heads

According to Indian standard specifications, the rivet heads are classified into the following three types :

1. Rivet heads for general purposes (below 12 mm diameter) as shown in Fig. 9.3, according to IS : 2155 – 1982 (Reaffirmed 1996).

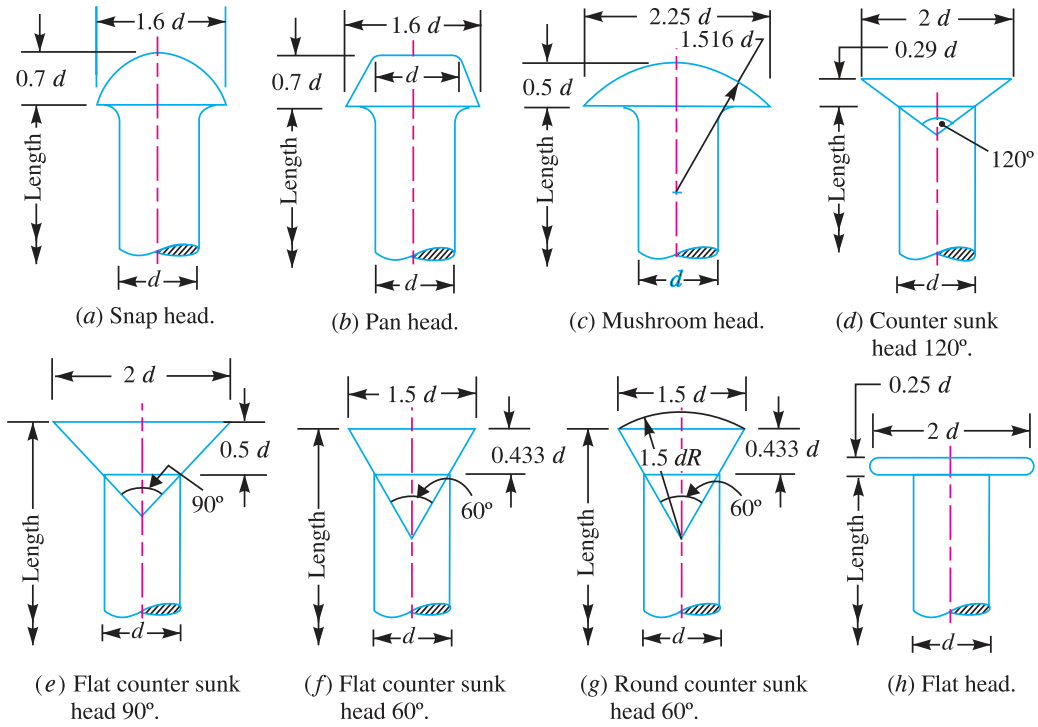

Fig. 9.3. Rivet heads for general purposes (below 12 mm diameter).

2. Rivet heads for general purposes (From 12 mm to 48 mm diameter) as shown in Fig. 9.4, according to IS : 1929 – 1982 (Reaffirmed 1996).

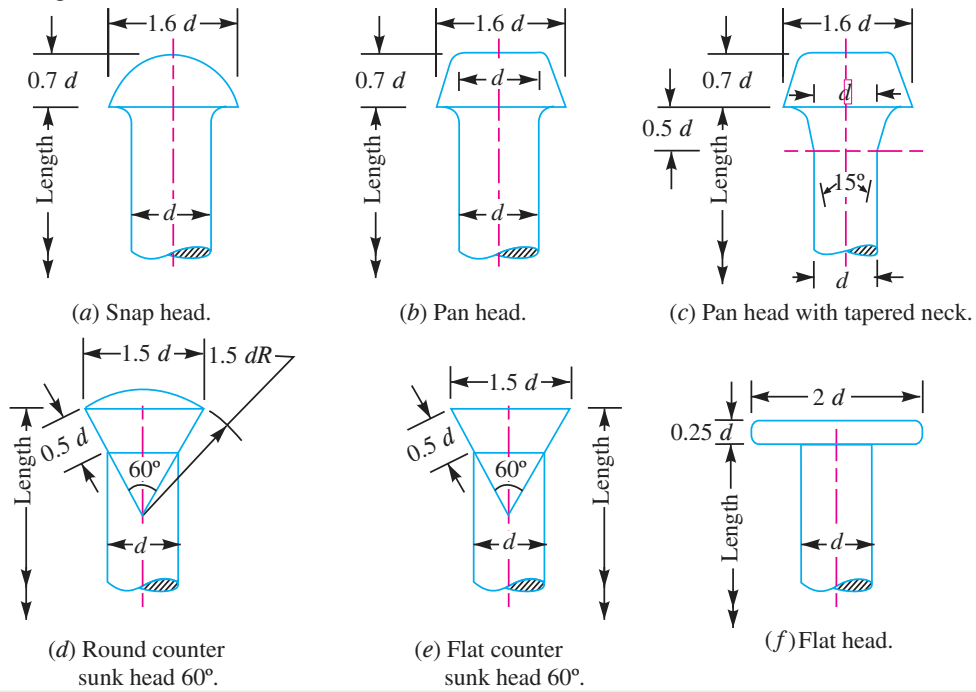

Fig. 9.4. Rivet heads for general purposes (from 12 mm to 48 mm diameter)

3. Rivet heads for boiler work (from 12 mm to 48 mm diameter, as shown in Fig. 9.5, according to IS : 1928 – 1961 (Reaffirmed 1996).

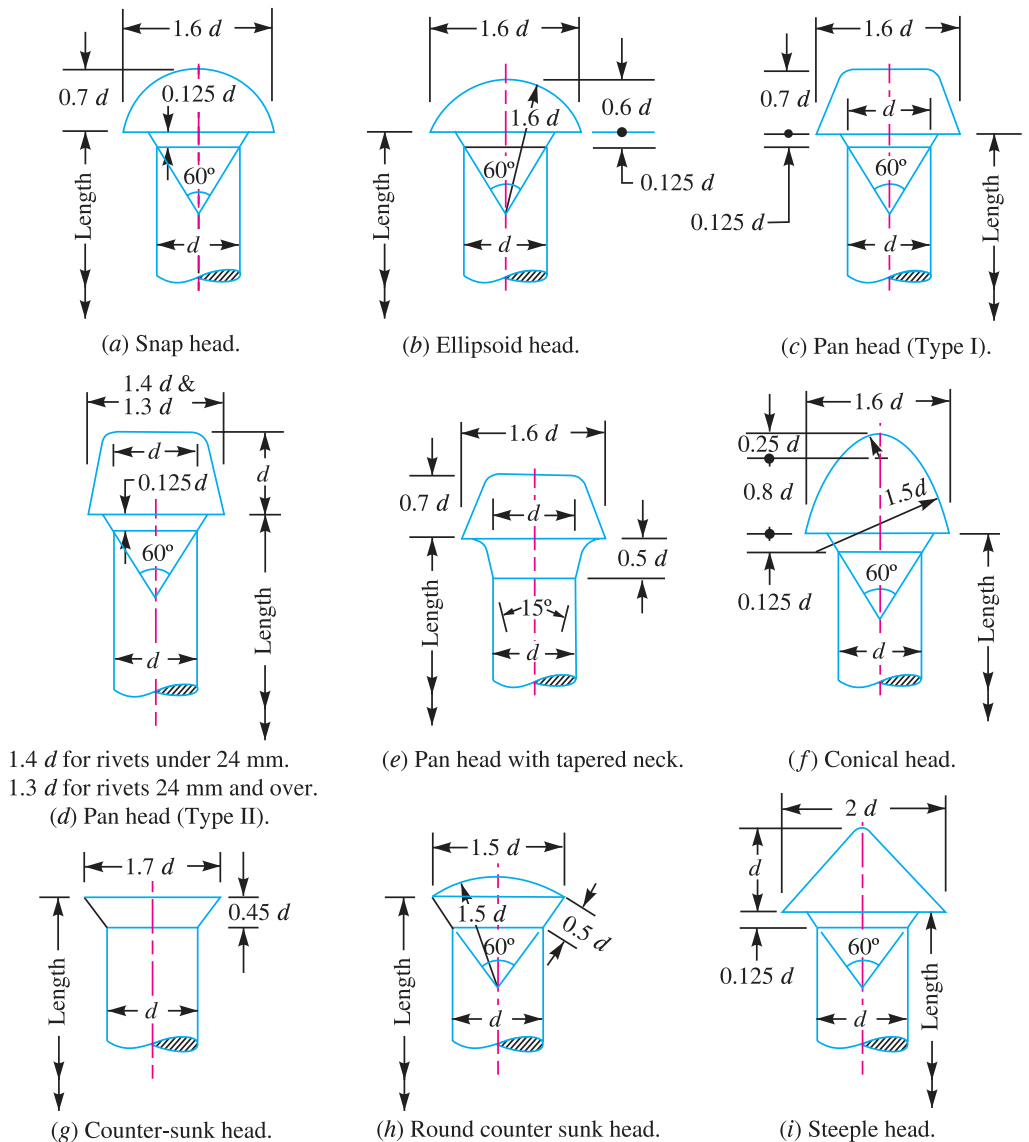

Fig. 9.5. Rivet heads for boiler work.

The **snap heads** are usually employed for structural work and machine riveting. The **counter sunk heads** are mainly used for ship building where flush surfaces are necessary. The **conical heads** (also known as **conoidal heads**) are mainly used in case of hand hammering. The **pan heads** have maximum strength, but these are difficult to shape.

9.7 Types of Riveted Joints

Following are the two types of riveted joints, depending upon the way in which the plates are connected.

1. Lap joint, and
2. Butt joint.

9.8 Lap Joint

A lap joint is that in which one plate overlaps the other and the two plates are then riveted together.

9.9 Butt Joint

A butt joint is that in which the main plates are kept in alignment butting (*i.e.* touching) each other and a cover plate (*i.e.* strap) is placed either on one side or on both sides of the main plates. The cover plate is then riveted together with the main plates. Butt joints are of the following two types :

1. Single strap butt joint, and 2. Double strap butt joint.

In a *single strap butt joint*, the edges of the main plates butt against each other and only one cover plate is placed on one side of the main plates and then riveted together.

In a *double strap butt joint*, the edges of the main plates butt against each other and two cover plates are placed on both sides of the main plates and then riveted together.

In addition to the above, following are the types of riveted joints depending upon the number of rows of the rivets.

1. Single riveted joint, and 2. Double riveted joint.

A *single riveted joint* is that in which there is a single row of rivets in a lap joint as shown in Fig. 9.6 (a) and there is a single row of rivets on each side in a butt joint as shown in Fig. 9.8.

A *double riveted joint* is that in which there are two rows of rivets in a lap joint as shown in Fig. 9.6 (b) and (c) and there are two rows of rivets on each side in a butt joint as shown in Fig. 9.9.

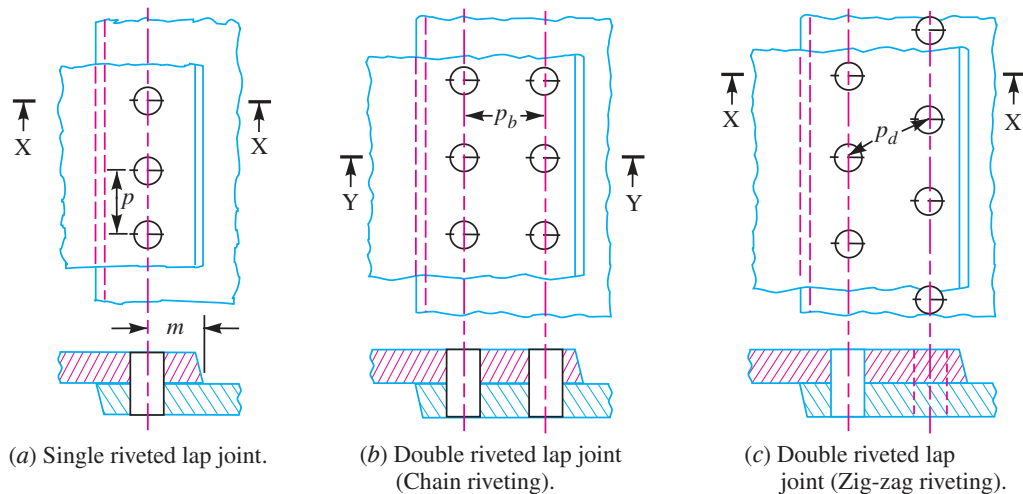

Fig. 9.6. Single and double riveted lap joints.

Similarly the joints may be *triple riveted* or *quadruple riveted*.

Notes : 1. When the rivets in the various rows are opposite to each other, as shown in Fig. 9.6 (b), then the joint is said to be *chain riveted*. On the other hand, if the rivets in the adjacent rows are staggered in such a way that



every rivet is in the middle of the two rivets of the opposite row as shown in Fig. 9.6 (c), then the joint is said to be *zig-zag riveted*.

2. Since the plates overlap in lap joints, therefore the force P, P acting on the plates [See Fig. 9.15 (a)] are not in the same straight line but they are at a distance equal to the thickness of the plate. These forces will form a couple which may bend the joint. Hence the lap joints may be used only where small loads are to be transmitted. On the other hand, the forces P, P in a butt joint [See Fig. 9.15 (b)] act in the same straight line, therefore there will be no couple. Hence the butt joints are used where heavy loads are to be transmitted.

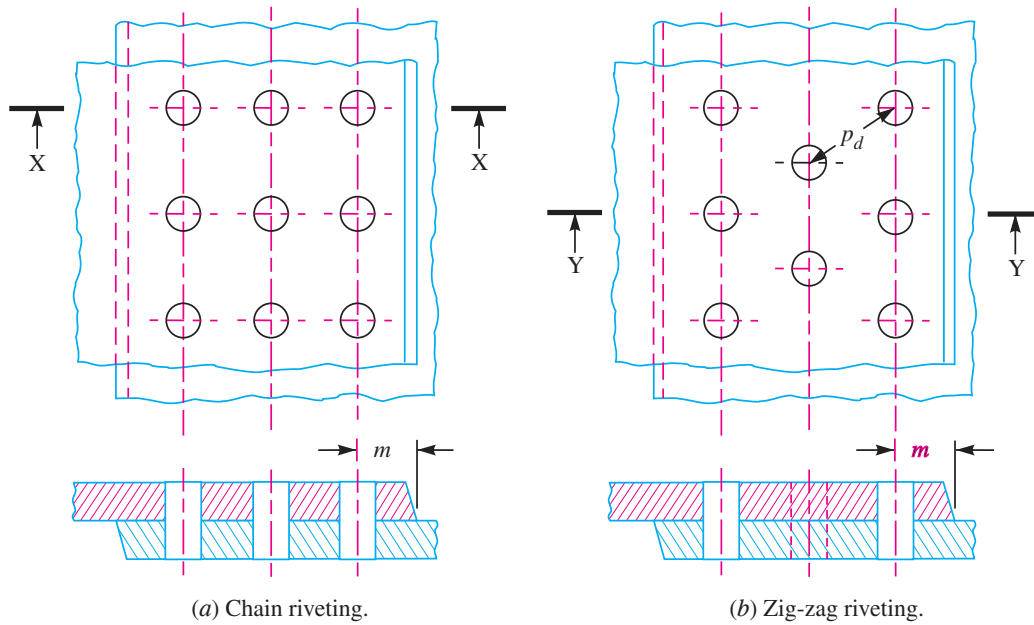

Fig. 9.7. Triple riveted lap joint.

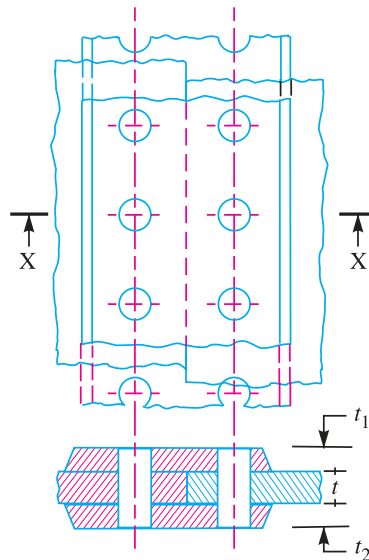

Fig. 9.8. Single riveted double strap butt joint.

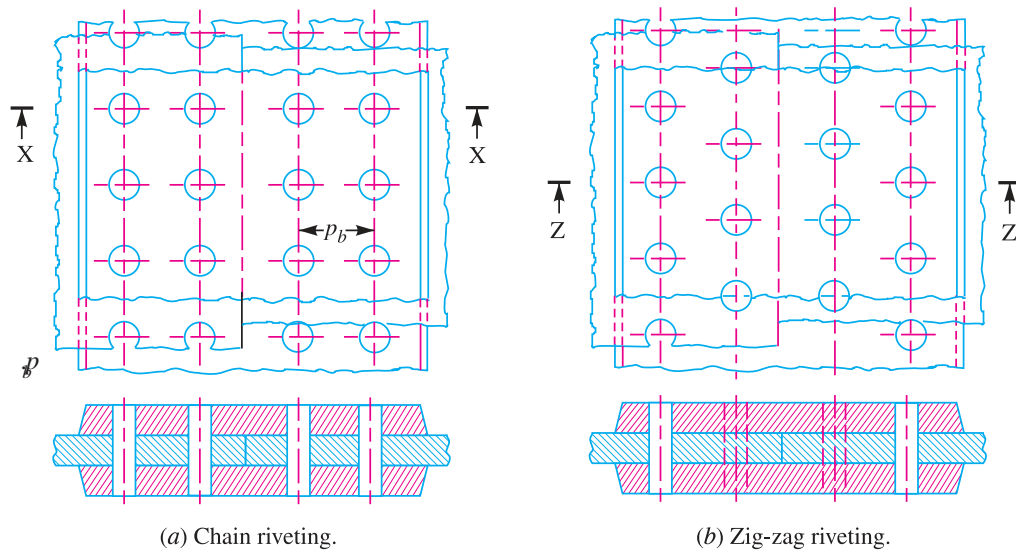

Fig. 9.9. Double riveted double strap (equal) butt joints.

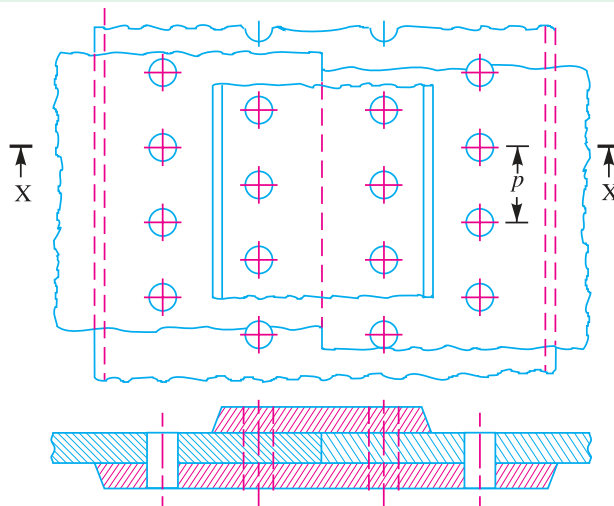

Fig. 9.10. Double riveted double strap (unequal) butt joint with zig-zag riveting.

9.10 Important Terms Used in Riveted Joints

The following terms in connection with the riveted joints are important from the subject point of view :

1. **Pitch.** It is the distance from the centre of one rivet to the centre of the next rivet measured parallel to the seam as shown in Fig. 9.6. It is usually denoted by p .
2. **Back pitch.** It is the perpendicular distance between the centre lines of the successive rows as shown in Fig. 9.6. It is usually denoted by p_b .
3. **Diagonal pitch.** It is the distance between the centres of the rivets in adjacent rows of zig-zag riveted joint as shown in Fig. 9.6. It is usually denoted by p_d .
4. **Margin or marginal pitch.** It is the distance between the centre of rivet hole to the nearest edge of the plate as shown in Fig. 9.6. It is usually denoted by m .

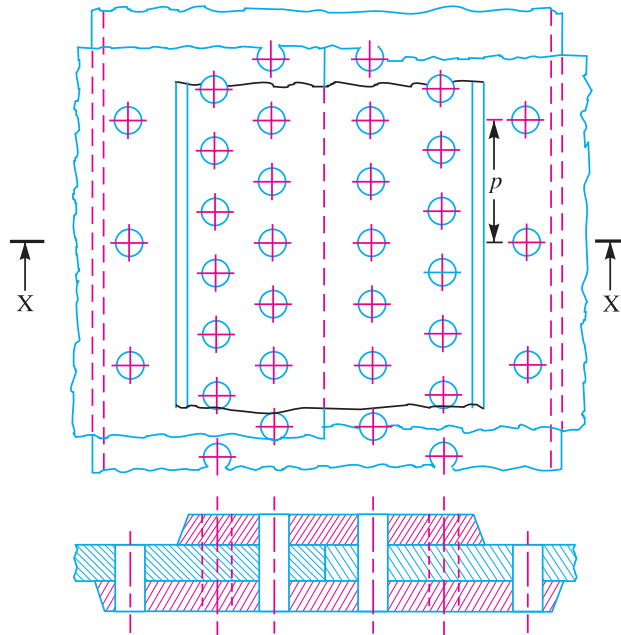

Fig. 9.11. Triple riveted double strap (unequal) butt joint.

9.11 Caulking and Fullering

In order to make the joints leak proof or fluid tight in pressure vessels like steam boilers, air receivers and tanks etc. a process known as **caulking** is employed. In this process, a narrow blunt tool called caulking tool, about 5 mm thick and 38 mm in breadth, is used. The edge of the tool is ground to an angle of 80°. The tool is moved after each blow along the edge of the plate, which is planed to a bevel of 75° to 80° to facilitate the forcing down of edge. It is seen that the tool burrs down the plate at A in Fig. 9.12 (a) forming a metal to metal joint. In actual practice, both the edges at A and



Caulking process is employed to make the joints leak proofs or fluid tight in steam boiler.

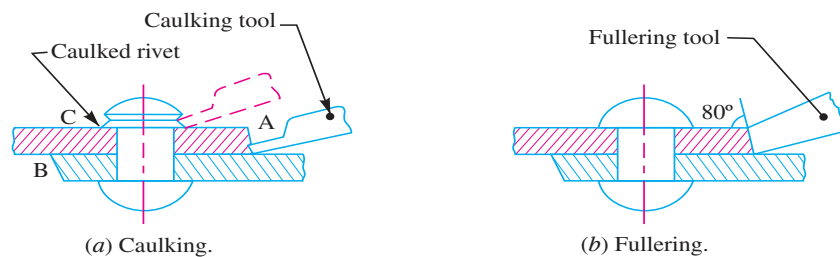

Fig. 9.12. Caulking and fullering.

B are caulked. The head of the rivets as shown at C are also turned down with a caulking tool to make a joint steam tight. A great care is taken to prevent injury to the plate below the tool.

A more satisfactory way of making the joints staunch is known as **fullering** which has largely superseded caulking. In this case, a fullering tool with a thickness at the end equal to that of the plate is used in such a way that the greatest pressure due to the blows occur near the joint, giving a clean finish, with less risk of damaging the plate. A fullering process is shown in Fig. 9.12 (b).

9.12 Failures of a Riveted Joint

A riveted joint may fail in the following ways :

1. Tearing of the plate at an edge. A joint may fail due to tearing of the plate at an edge as shown in Fig. 9.13. This can be avoided by keeping the margin, $m = 1.5d$, where d is the diameter of the rivet hole.

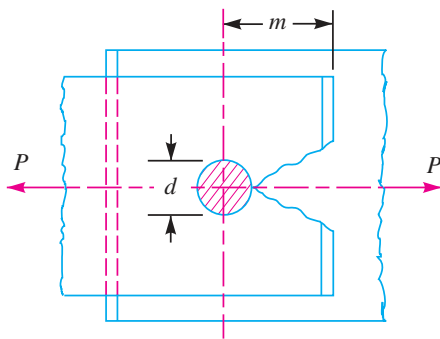

Fig. 9.13. Tearing of the plate at an edge.

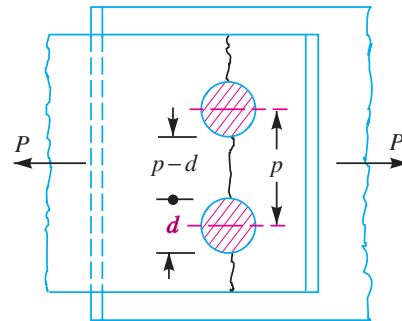

Fig. 9.14. Tearing of the plate across the rows of rivets.

2. Tearing of the plate across a row of rivets. Due to the tensile stresses in the main plates, the main plate or cover plates may tear off across a row of rivets as shown in Fig. 9.14. In such cases, we consider only one pitch length of the plate, since every rivet is responsible for that much length of the plate only.

The resistance offered by the plate against tearing is known as **tearing resistance** or **tearing strength** or **tearing value** of the plate.

- Let
- p = Pitch of the rivets,
 - d = Diameter of the rivet hole,
 - t = Thickness of the plate, and
 - σ_t = Permissible tensile stress for the plate material.

We know that tearing area per pitch length,

$$A_t = (p - d)t$$

∴ Tearing resistance or pull required to tear off the plate per pitch length,

$$P_t = A_t \sigma_t = (p - d)t \sigma_t$$

When the tearing resistance (P_t) is greater than the applied load (P) per pitch length, then this type of failure will not occur.

3. Shearing of the rivets. The plates which are connected by the rivets exert tensile stress on the rivets, and if the rivets are unable to resist the stress, they are sheared off as shown in Fig. 9.15.

It may be noted that the rivets are in *single shear in a lap joint and in a single cover butt joint, as shown in Fig. 9.15. But the rivets are in double shear in a double cover butt joint as shown in Fig. 9.16. The resistance offered by a rivet to be sheared off is known as *shearing resistance* or *shearing strength* or *shearing value* of the rivet.

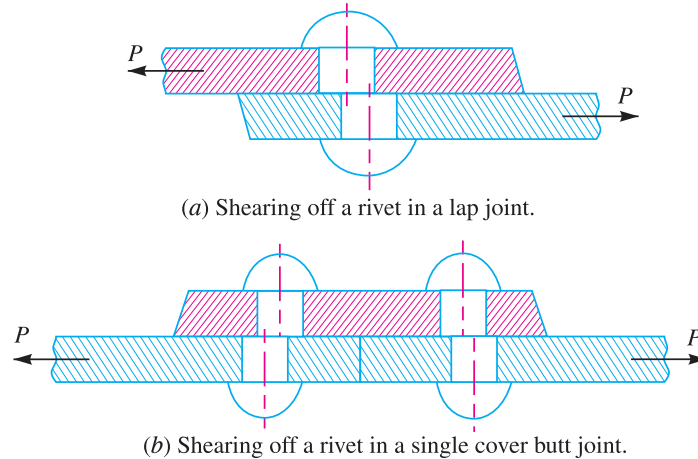

Fig. 9.15. Shearing of rivets.

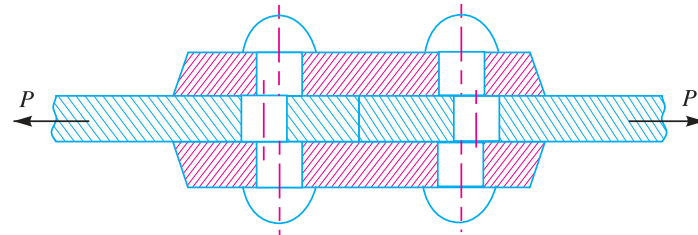

Fig. 9.16. Shearing off a rivet in double cover butt joint.

Let d = Diameter of the rivet hole,
 τ = Safe permissible shear stress for the rivet material, and
 n = Number of rivets per pitch length.

We know that shearing area,

$$\begin{aligned}
 A_s &= \frac{\pi}{4} \times d^2 && \dots(\text{In single shear}) \\
 &= 2 \times \frac{\pi}{4} \times d^2 && \dots(\text{Theoretically, in double shear}) \\
 &= 1.875 \times \frac{\pi}{4} \times d^2 && \dots(\text{In double shear, according to Indian Boiler Regulations})
 \end{aligned}$$

∴ Shearing resistance or pull required to shear off the rivet per pitch length,

$$\begin{aligned}
 P_s &= n \times \frac{\pi}{4} \times d^2 \times \tau && \dots(\text{In single shear}) \\
 &= n \times 2 \times \frac{\pi}{4} \times d^2 \times \tau && \dots(\text{Theoretically, in double shear})
 \end{aligned}$$

* We have already discussed in Chapter 4 (Art. 4.8) that when the shearing takes place at one cross-section of the rivet, then the rivets are said to be in *single shear*. Similarly, when the shearing takes place at two cross-sections of the rivet, then the rivets are said to be in *double shear*.

$$= n \times 1.875 \times \frac{\pi}{4} \times d^2 \times \tau \dots (\text{In double shear, according to Indian Boiler Regulations})$$

When the shearing resistance (P_s) is greater than the applied load (P) per pitch length, then this type of failure will occur.

4. Crushing of the plate or rivets. Sometimes, the rivets do not actually shear off under the tensile stress, but are crushed as shown in Fig. 9.17. Due to this, the rivet hole becomes of an oval shape and hence the joint becomes loose. The failure of rivets in such a manner is also known as **bearing failure**. The area which resists this action is the projected area of the hole or rivet on diametral plane.

The resistance offered by a rivet to be crushed is known as **crushing resistance** or **crushing strength** or **bearing value** of the rivet.

- Let
- d = Diameter of the rivet hole,
 - t = Thickness of the plate,
 - σ_c = Safe permissible crushing stress for the rivet or plate material, and
 - n = Number of rivets per pitch length under crushing.

We know that crushing area per rivet (*i.e.* projected area per rivet),

$$A_c = d.t$$

$$\therefore \text{Total crushing area} = n.d.t$$

and crushing resistance or pull required to crush the rivet per pitch length,

$$P_c = n.d.t.\sigma_c$$

When the crushing resistance (P_c) is greater than the applied load (P) per pitch length, then this type of failure will occur.

Note : The number of rivets under shear shall be equal to the number of rivets under crushing.

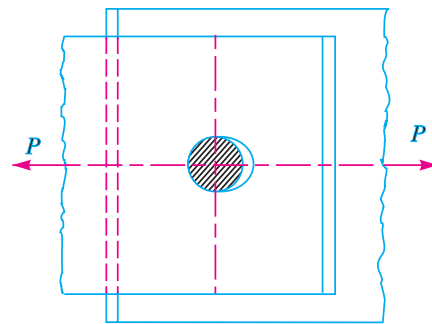

Fig. 9.17. Crushing of a rivet.

9.13 Strength of a Riveted Joint

The strength of a joint may be defined as the maximum force, which it can transmit, without causing it to fail. We have seen in Art. 9.12 that P_p , P_s and P_c are the pulls required to tear off the plate, shearing off the rivet and crushing off the rivet. A little consideration will show that if we go on increasing the pull on a riveted joint, it will fail when the least of these three pulls is reached, because a higher value of the other pulls will never reach since the joint has failed, either by tearing off the plate, shearing off the rivet or crushing off the rivet.

If the joint is **continuous** as in case of boilers, the strength is calculated **per pitch length**. But if the joint is **small**, the strength is calculated for the **whole length** of the plate.

9.14 Efficiency of a Riveted Joint

The efficiency of a riveted joint is defined as the ratio of the strength of riveted joint to the strength of the un-riveted or solid plate.

- We have already discussed that strength of the riveted joint
- = Least of P_p , P_s and P_c

Strength of the un-riveted or solid plate per pitch length,

$$P = p \times t \times \sigma_t$$

∴ Efficiency of the riveted joint,

$$\eta = \frac{\text{Least of } P_t, P_s \text{ and } P_c}{p \times t \times \sigma_t}$$

where

p = Pitch of the rivets,

t = Thickness of the plate, and

σ_t = Permissible tensile stress of the plate material.

Example 9.1. A double riveted lap joint is made between 15 mm thick plates. The rivet diameter and pitch are 25 mm and 75 mm respectively. If the ultimate stresses are 400 MPa in tension, 320 MPa in shear and 640 MPa in crushing, find the minimum force per pitch which will rupture the joint.

If the above joint is subjected to a load such that the factor of safety is 4, find out the actual stresses developed in the plates and the rivets.

Solution. Given : $t = 15$ mm ; $d = 25$ mm ; $p = 75$ mm ; $\sigma_{tu} = 400$ MPa = 400 N/mm² ; $\tau_u = 320$ MPa = 320 N/mm² ; $\sigma_{cu} = 640$ MPa = 640 N/mm²

Minimum force per pitch which will rupture the joint

Since the ultimate stresses are given, therefore we shall find the ultimate values of the resistances of the joint. We know that ultimate tearing resistance of the plate per pitch,

$$P_{tu} = (p - d)t \times \sigma_{tu} = (75 - 25)15 \times 400 = 300\,000 \text{ N}$$

Ultimate shearing resistance of the rivets per pitch,

$$P_{su} = n \times \frac{\pi}{4} \times d^2 \times \tau_u = 2 \times \frac{\pi}{4} (25)^2 \times 320 = 314\,200 \text{ N} \quad \dots (\because n = 2)$$

and ultimate crushing resistance of the rivets per pitch,

$$P_{cu} = n \times d \times t \times \sigma_{cu} = 2 \times 25 \times 15 \times 640 = 480\,000 \text{ N}$$

From above we see that the minimum force per pitch which will rupture the joint is 300 000 N or 300 kN. **Ans.**

Actual stresses produced in the plates and rivets

Since the factor of safety is 4, therefore safe load per pitch length of the joint
= 300 000/4 = 75 000 N

Let σ_{ta} , τ_a and σ_{ca} be the actual tearing, shearing and crushing stresses produced with a safe load of 75 000 N in tearing, shearing and crushing.

We know that actual tearing resistance of the plates (P_{ta}),

$$75\,000 = (p - d)t \times \sigma_{ta} = (75 - 25)15 \times \sigma_{ta} = 750 \sigma_{ta}$$

$$\therefore \sigma_{ta} = 75\,000 / 750 = 100 \text{ N/mm}^2 = 100 \text{ MPa} \quad \text{Ans.}$$

Actual shearing resistance of the rivets (P_{sa}),

$$75\,000 = n \times \frac{\pi}{4} \times d^2 \times \tau_a = 2 \times \frac{\pi}{4} (25)^2 \tau_a = 982 \tau_a$$

$$\therefore \tau_a = 75\,000 / 982 = 76.4 \text{ N/mm}^2 = 76.4 \text{ MPa} \quad \text{Ans.}$$

and actual crushing resistance of the rivets (P_{ca}),

$$75\,000 = n \times d \times t \times \sigma_{ca} = 2 \times 25 \times 15 \times \sigma_{ca} = 750 \sigma_{ca}$$

$$\therefore \sigma_{ca} = 75\,000 / 750 = 100 \text{ N/mm}^2 = 100 \text{ MPa} \quad \text{Ans.}$$

Example 9.2. Find the efficiency of the following riveted joints :

1. Single riveted lap joint of 6 mm plates with 20 mm diameter rivets having a pitch of 50 mm.
2. Double riveted lap joint of 6 mm plates with 20 mm diameter rivets having a pitch of 65 mm.

Assume

Permissible tensile stress in plate = 120 MPa

Permissible shearing stress in rivets = 90 MPa

Permissible crushing stress in rivets = 180 MPa

Solution. Given : $t = 6 \text{ mm}$; $d = 20 \text{ mm}$; $\sigma_t = 120 \text{ MPa} = 120 \text{ N/mm}^2$; $\tau = 90 \text{ MPa} = 90 \text{ N/mm}^2$; $\sigma_c = 180 \text{ MPa} = 180 \text{ N/mm}^2$

1. Efficiency of the first joint

Pitch, $p = 50 \text{ mm}$... (Given)

First of all, let us find the tearing resistance of the plate, shearing and crushing resistances of the rivets.

(i) Tearing resistance of the plate

We know that the tearing resistance of the plate per pitch length,

$$P_t = (p - d) t \times \sigma_t = (50 - 20) 6 \times 120 = 21\,600 \text{ N}$$

(ii) Shearing resistance of the rivet

Since the joint is a single riveted lap joint, therefore the strength of one rivet in single shear is taken. We know that shearing resistance of one rivet,

$$P_s = \frac{\pi}{4} \times d^2 \times \tau = \frac{\pi}{4} (20)^2 90 = 28\,278 \text{ N}$$

(iii) Crushing resistance of the rivet

Since the joint is a single riveted, therefore strength of one rivet is taken. We know that crushing resistance of one rivet,

$$P_c = d \times t \times \sigma_c = 20 \times 6 \times 180 = 21\,600 \text{ N}$$

∴ Strength of the joint

$$= \text{Least of } P_t, P_s \text{ and } P_c = 21\,600 \text{ N}$$

We know that strength of the unriveted or solid plate,

$$P = p \times t \times \sigma_t = 50 \times 6 \times 120 = 36\,000 \text{ N}$$

∴ Efficiency of the joint,

$$\eta = \frac{\text{Least of } P_t, P_s \text{ and } P_c}{P} = \frac{21\,600}{36\,000} = 0.60 \text{ or } 60\% \quad \text{Ans.}$$

2. Efficiency of the second joint

Pitch, $p = 65 \text{ mm}$... (Given)

(i) Tearing resistance of the plate,

We know that the tearing resistance of the plate per pitch length,

$$P_t = (p - d) t \times \sigma_t = (65 - 20) 6 \times 120 = 32\,400 \text{ N}$$

(ii) Shearing resistance of the rivets

Since the joint is double riveted lap joint, therefore strength of two rivets in single shear is taken. We know that shearing resistance of the rivets,

$$P_s = n \times \frac{\pi}{4} \times d^2 \times \tau = 2 \times \frac{\pi}{4} (20)^2 90 = 56\,556 \text{ N}$$

(iii) Crushing resistance of the rivet

Since the joint is double riveted, therefore strength of two rivets is taken. We know that crushing resistance of rivets,

$$P_c = n \times d \times t \times \sigma_c = 2 \times 20 \times 6 \times 180 = 43\,200 \text{ N}$$

∴ Strength of the joint

$$= \text{Least of } P_t, P_s \text{ and } P_c = 32\,400 \text{ N}$$

We know that the strength of the unriveted or solid plate,

$$P = p \times t \times \sigma_t = 65 \times 6 \times 120 = 46\,800 \text{ N}$$

∴ Efficiency of the joint,

$$\eta = \frac{\text{Least of } P_t, P_s \text{ and } P_c}{P} = \frac{32\,400}{46\,800} = 0.692 \text{ or } 69.2\% \quad \text{Ans.}$$

Example 9.3. A double riveted double cover butt joint in plates 20 mm thick is made with 25 mm diameter rivets at 100 mm pitch. The permissible stresses are :

$$\sigma_t = 120 \text{ MPa}; \quad \tau = 100 \text{ MPa}; \quad \sigma_c = 150 \text{ MPa}$$

Find the efficiency of joint, taking the strength of the rivet in double shear as twice than that of single shear.

Solution. Given : $t = 20 \text{ mm}$; $d = 25 \text{ mm}$; $p = 100 \text{ mm}$; $\sigma_t = 120 \text{ MPa} = 120 \text{ N/mm}^2$; $\tau = 100 \text{ MPa} = 100 \text{ N/mm}^2$; $\sigma_c = 150 \text{ MPa} = 150 \text{ N/mm}^2$

First of all, let us find the tearing resistance of the plate, shearing resistance and crushing resistance of the rivet.

(i) Tearing resistance of the plate

We know that tearing resistance of the plate per pitch length,

$$P_t = (p - d) t \times \sigma_t = (100 - 25) 20 \times 120 = 180\,000 \text{ N}$$

(ii) Shearing resistance of the rivets

Since the joint is double riveted butt joint, therefore the strength of two rivets in double shear is taken. We know that shearing resistance of the rivets,

$$P_s = n \times 2 \times \frac{\pi}{4} \times d^2 \times \tau = 2 \times 2 \times \frac{\pi}{4} (25)^2 100 = 196\,375 \text{ N}$$

(iii) Crushing resistance of the rivets

Since the joint is double riveted, therefore the strength of two rivets is taken. We know that crushing resistance of the rivets,

$$P_c = n \times d \times t \times \sigma_c = 2 \times 25 \times 20 \times 150 = 150\,000 \text{ N}$$

∴ Strength of the joint

$$= \text{Least of } P_t, P_s \text{ and } P_c \\ = 150\,000 \text{ N}$$

Efficiency of the joint

We know that the strength of the unriveted or solid plate,

$$P = p \times t \times \sigma_t = 100 \times 20 \times 120 \\ = 240\,000 \text{ N}$$

∴ Efficiency of the joint

$$= \frac{\text{Least of } P_t, P_s \text{ and } P_c}{P} = \frac{150\,000}{240\,000} \\ = 0.625 \text{ or } 62.5\% \quad \text{Ans.}$$

9.15 Design of Boiler Joints

The boiler has a longitudinal joint as well as circumferential joint. The *longitudinal joint* is used to join the ends of the plate to get the required diameter of a boiler. For this purpose, a butt joint with two cover plates is used. The

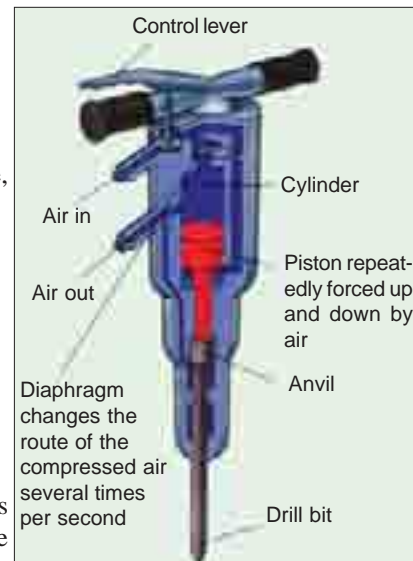

Pneumatic drill uses compressed air.

circumferential joint is used to get the required length of the boiler. For this purpose, a lap joint with one ring overlapping the other alternately is used.

Since a boiler is made up of number of rings, therefore the longitudinal joints are staggered for convenience of connecting rings at places where both longitudinal and circumferential joints occur.

9.16 Assumptions in Designing Boiler Joints

The following assumptions are made while designing a joint for boilers :

1. The load on the joint is equally shared by all the rivets. The assumption implies that the shell and plate are rigid and that all the deformation of the joint takes place in the rivets themselves.
2. The tensile stress is equally distributed over the section of metal between the rivets.
3. The shearing stress in all the rivets is uniform.
4. The crushing stress is uniform.
5. There is no bending stress in the rivets.
6. The holes into which the rivets are driven do not weaken the member.
7. The rivet fills the hole after it is driven.
8. The friction between the surfaces of the plate is neglected.

9.17 Design of Longitudinal Butt Joint for a Boiler

According to Indian Boiler Regulations (I.B.R), the following procedure should be adopted for the design of longitudinal butt joint for a boiler.

1. **Thickness of boiler shell.** First of all, the thickness of the boiler shell is determined by using the thin cylindrical formula, *i.e.*

$$t = \frac{P.D}{2 \sigma_t \times \eta_l} + 1 \text{ mm as corrosion allowance}$$

where

t = Thickness of the boiler shell,

P = Steam pressure in boiler,

D = Internal diameter of boiler shell,

σ_t = Permissible tensile stress, and

η_l = Efficiency of the longitudinal joint.

The following points may be noted :

- (a) The thickness of the boiler shell should not be less than 7 mm.
- (b) The efficiency of the joint may be taken from the following table.

Table 9.1. Efficiencies of commercial boiler joints.

<i>Lap joints</i>	<i>Efficiency (%)</i>	<i>*Maximum efficiency</i>	<i>Butt joints (Double strap)</i>	<i>Efficiency (%)</i>	<i>*Maximum efficiency</i>
Single riveted	45 to 60	63.3	Single riveted	55 to 60	63.3
Double riveted	63 to 70	77.5	Double riveted	70 to 83	86.6
Triple riveted	72 to 80	86.6	Triple riveted	80 to 90	95.0
			(5 rivets per pitch with unequal width of straps)		
			Quadruple riveted	85 to 94	98.1

* The maximum efficiencies are valid for ideal equistrength joints with tensile stress = 77 MPa, shear stress = 62 MPa and crushing stress = 133 MPa.

Indian Boiler Regulations (I.B.R.) allow a maximum efficiency of 85% for the best joint.

- (c) According to I.B.R., the factor of safety should not be less than 4. The following table shows the values of factor of safety for various kind of joints in boilers.

Table 9.2. Factor of safety for boiler joints.

Type of joint	Factor of safety	
	Hand riveting	Machine riveting
Lap joint	4.75	4.5
Single strap butt joint	4.75	4.5
Single riveted butt joint with two equal cover straps	4.75	4.5
Double riveted butt joint with two equal cover straps	4.25	4.0

2. Diameter of rivets. After finding out the thickness of the boiler shell (t), the diameter of the rivet hole (d) may be determined by using Unwin's empirical formula, *i.e.*

$$d = 6\sqrt{t} \quad (\text{when } t \text{ is greater than } 8 \text{ mm})$$

But if the thickness of plate is less than 8 mm, then the diameter of the rivet hole may be calculated by equating the shearing resistance of the rivets to crushing resistance. In no case, the diameter of rivet hole should not be less than the thickness of the plate, because there will be danger of punch crushing. The following table gives the rivet diameter corresponding to the diameter of rivet hole as per IS : 1928 – 1961 (Reaffirmed 1996).

Table 9.3. Size of rivet diameters for rivet hole diameter as per IS : 1928 – 1961 (Reaffirmed 1996).

Basic size of rivet mm	12	14	16	18	20	22	24	27	30	33	36	39	42	48
Rivet hole diameter (min) mm	13	15	17	19	21	23	25	28.5	31.5	34.5	37.5	41	44	50

According to IS : 1928 – 1961 (Reaffirmed 1996), the table on the next page (Table 9.4) gives the preferred length and diameter combination for rivets.

3. Pitch of rivets. The pitch of the rivets is obtained by equating the tearing resistance of the plate to the shearing resistance of the rivets. It may be noted that

- (a) The pitch of the rivets should not be less than $2d$, which is necessary for the formation of head.
- (b) The maximum value of the pitch of rivets for a longitudinal joint of a boiler as per I.B.R. is

$$p_{max} = C \times t + 41.28 \text{ mm}$$

where

t = Thickness of the shell plate in mm, and

C = Constant.

The value of the constant C is given in Table 9.5.

Table 9.4. Preferred length and diameter combinations for rivets used in boilers as per IS : 1928-1961 (Reaffirmed 1996).

(All dimensions in mm)

Length	Diameter													
	12	14	16	18	20	22	24	27	30	33	36	39	42	48
28	×	–	–	–	–	–	–	–	–	–	–	–	–	–
31.5	×	×	–	–	–	–	–	–	–	–	–	–	–	–
35.5	×	×	×	–	–	–	–	–	–	–	–	–	–	–
40	×	×	×	×	–	–	–	–	–	–	–	–	–	–
45	×	×	×	×	×	–	–	–	–	–	–	–	–	–
50	×	×	×	×	×	×	–	–	–	–	–	–	–	–
56	×	×	×	×	×	×	×	–	–	–	–	–	–	–
63	×	×	×	×	×	×	×	×	–	–	–	–	–	–
71	×	×	×	×	×	×	×	×	×	–	–	–	–	–
80	×	×	×	×	×	×	×	×	×	–	–	–	–	–
85	–	×	×	×	×	×	×	×	×	×	–	–	–	–
90	–	×	×	×	×	×	×	×	×	×	–	–	–	–
95	–	×	×	×	×	×	×	×	×	×	×	–	–	–
100	–	–	×	×	×	×	×	×	×	×	×	–	–	–
106	–	–	×	×	×	×	×	×	×	×	×	×	–	–
112	–	–	×	×	×	×	×	×	×	×	×	×	–	–
118	–	–	–	×	×	×	×	×	×	×	×	×	×	–
125	–	–	–	–	×	×	×	×	×	×	×	×	×	×
132	–	–	–	–	–	×	×	×	×	×	×	×	×	×
140	–	–	–	–	–	×	×	×	×	×	×	×	×	×
150	–	–	–	–	–	–	×	×	×	×	×	×	×	×
160	–	–	–	–	–	–	×	×	×	×	×	×	×	×
180	–	–	–	–	–	–	–	×	×	×	×	×	×	×
200	–	–	–	–	–	–	–	–	×	×	×	×	×	×
224	–	–	–	–	–	–	–	–	–	×	×	×	×	×
250	–	–	–	–	–	–	–	–	–	–	–	–	×	×

Preferred numbers are indicated by ×.

Table 9.5. Values of constant C.

Number of rivets per pitch length	Lap joint	Butt joint (single strap)	Butt joint (double strap)
1	1.31	1.53	1.75
2	2.62	3.06	3.50
3	3.47	4.05	4.63
4	4.17	–	5.52
5	–	–	6.00

Note : If the pitch of rivets as obtained by equating the tearing resistance to the shearing resistance is more than p_{max} , then the value of p_{max} is taken.

4. Distance between the rows of rivets. The distance between the rows of rivets as specified by Indian Boiler Regulations is as follows :

- (a) For equal number of rivets in more than one row for lap joint or butt joint, the distance between the rows of rivets (p_b) should not be less than

$$0.33 p + 0.67 d, \text{ for zig-zig riveting, and}$$

$$2 d, \text{ for chain riveting.}$$

- (b) For joints in which the number of rivets in outer rows is **half** the number of rivets in inner rows and if the inner rows are chain riveted, the distance between the outer rows and the next rows should not be less than

$$0.33 p + 0.67 d \quad \text{or} \quad 2 d, \text{ whichever is greater.}$$

The distance between the rows in which there are full number of rivets shall not be less than $2d$.

- (c) For joints in which the number of rivets in outer rows is **half** the number of rivets in inner rows and if the inner rows are zig-zig riveted, the distance between the outer rows and the next rows shall not be less than $0.2 p + 1.15 d$. The distance between the rows in which there are full number of rivets (zig-zag) shall not be less than $0.165 p + 0.67 d$.

Note : In the above discussion, p is the pitch of the rivets in the outer rows.

5. Thickness of butt strap. According to I.B.R., the thicknesses for butt strap (t_1) are as given below :

- (a) The thickness of butt strap, in no case, shall be less than 10 mm.

- (b) $t_1 = 1.125 t$, for ordinary (chain riveting) single butt strap.

$$t_1 = 1.125 t \left(\frac{p - d}{p - 2d} \right), \text{ for single butt straps, every alternate rivet in outer rows being omitted.}$$

$$t_1 = 0.625 t, \text{ for double butt-straps of equal width having ordinary riveting (chain riveting).}$$

$$t_1 = 0.625 t \left(\frac{p - d}{p - 2d} \right), \text{ for double butt straps of equal width having every alternate rivet in the outer rows being omitted.}$$

- (c) For unequal width of butt straps, the thicknesses of butt strap are

$$t_1 = 0.75 t, \text{ for wide strap on the inside, and}$$

$$t_2 = 0.625 t, \text{ for narrow strap on the outside.}$$

- 6. Margin.** The margin (m) is taken as $1.5 d$.

Note : The above procedure may also be applied to ordinary riveted joints.

9.18 Design of Circumferential Lap Joint for a Boiler

The following procedure is adopted for the design of circumferential lap joint for a boiler.

1. Thickness of the shell and diameter of rivets. The thickness of the boiler shell and the diameter of the rivet will be same as for longitudinal joint.

2. Number of rivets. Since it is a lap joint, therefore the rivets will be in single shear.

∴ Shearing resistance of the rivets,

$$P_s = n \times \frac{\pi}{4} \times d^2 \times \tau \quad \dots(i)$$

where $n =$ Total number of rivets.

Knowing the inner diameter of the boiler shell (D), and the pressure of steam (P), the total shearing load acting on the circumferential joint,

$$W_s = \frac{\pi}{4} \times D^2 \times P \quad \dots(ii)$$

From equations (i) and (ii), we get

$$n \times \frac{\pi}{4} \times d^2 \times \tau = \frac{\pi}{4} \times D^2 \times P$$

$$\therefore n = \left(\frac{D}{d}\right)^2 \frac{P}{\tau}$$

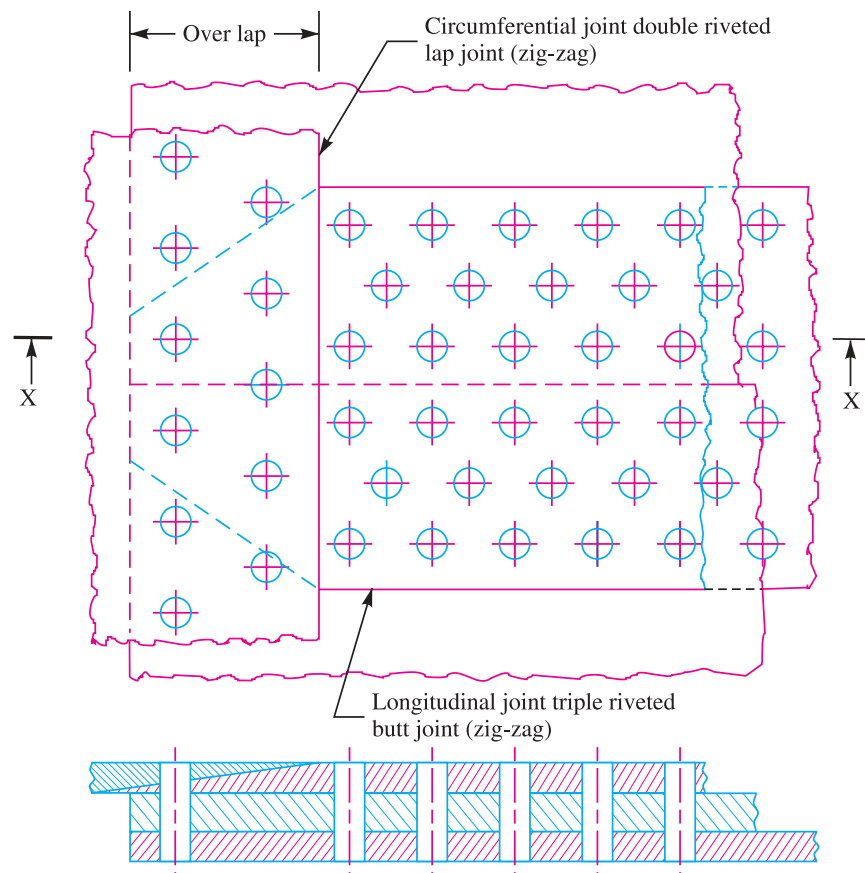

Fig. 9.18. Longitudinal and circumferential joint.

3. Pitch of rivets. If the efficiency of the longitudinal joint is known, then the efficiency of the circumferential joint may be obtained. It is generally taken as 50% of tearing efficiency in longitudinal joint, but if more than one circumferential joints is used, then it is 62% for the intermediate joints. Knowing the efficiency of the circumferential lap joint (η_c), the pitch of the rivets for the lap joint

(p_1) may be obtained by using the relation :

$$\eta_c = \frac{p_1 - d}{p_1}$$

4. Number of rows. The number of rows of rivets for the circumferential joint may be obtained from the following relation :

$$\text{Number of rows} = \frac{\text{Total number of rivets}}{\text{Number of rivets in one row}}$$

and the number of rivets in one row

$$= \frac{\pi (D + t)}{p_1}$$

where

D = Inner diameter of shell.

5. After finding out the number of rows, the type of the joint (*i.e.* single riveted or double riveted etc.) may be decided. Then the number of rivets in a row and pitch may be re-adjusted. In order to have a leak-proof joint, the pitch for the joint should be checked from Indian Boiler Regulations.

6. The distance between the rows of rivets (*i.e.* back pitch) is calculated by using the relations as discussed in the previous article.

7. After knowing the distance between the rows of rivets (p_b), the overlap of the plate may be fixed by using the relation,

$$\text{Overlap} = (\text{No. of rows of rivets} - 1) p_b + m$$

where

m = Margin.

There are several ways of joining the longitudinal joint and the circumferential joint. One of the methods of joining the longitudinal and circumferential joint is shown in Fig. 9.18.

9.19 Recommended Joints for Pressure Vessels

The following table shows the recommended joints for pressure vessels.

Table 9.6. Recommended joints for pressure vessels.

Diameter of shell (metres)	Thickness of shell (mm)	Type of joint
0.6 to 1.8	6 to 13	Double riveted
0.9 to 2.1	13 to 25	Triple riveted
1.5 to 2.7	19 to 40	Quadruple riveted

Example 9.4. A double riveted lap joint with zig-zag riveting is to be designed for 13 mm thick plates. Assume

$$\sigma_t = 80 \text{ MPa} ; \tau = 60 \text{ MPa} ; \text{ and } \sigma_c = 120 \text{ MPa}$$

State how the joint will fail and find the efficiency of the joint.

Solution. Given : $t = 13 \text{ mm} ; \sigma_t = 80 \text{ MPa} = 80 \text{ N/mm}^2 ; \tau = 60 \text{ MPa} = 60 \text{ N/mm}^2 ; \sigma_c = 120 \text{ MPa} = 120 \text{ N/mm}^2$

1. Diameter of rivet

Since the thickness of plate is greater than 8 mm, therefore diameter of rivet hole,

$$d = 6\sqrt{t} = 6\sqrt{13} = 21.6 \text{ mm}$$

From Table 9.3, we find that according to IS : 1928 – 1961 (Reaffirmed 1996), the standard size of the rivet hole (d) is 23 mm and the corresponding diameter of the rivet is 22 mm. **Ans.**

2. Pitch of rivets

Let p = Pitch of the rivets.

Since the joint is a double riveted lap joint with zig-zag riveting [See Fig. 9.6 (c)], therefore there are two rivets per pitch length, i.e. $n = 2$. Also, in a lap joint, the rivets are in single shear.

We know that tearing resistance of the plate,

$$P_t = (p - d)t \times \sigma_t = (p - 23) 13 \times 80 = (p - 23) 1040 \text{ N} \quad \dots(i)$$

and shearing resistance of the rivets,

$$P_s = n \times \frac{\pi}{4} \times d^2 \times \tau = 2 \times \frac{\pi}{4} (23)^2 60 = 49\,864 \text{ N} \quad \dots(ii)$$

...(\because There are two rivets in single shear)

From equations (i) and (ii), we get

$$p - 23 = 49864 / 1040 = 48 \quad \text{or} \quad p = 48 + 23 = 71 \text{ mm}$$

The maximum pitch is given by,

$$p_{max} = C \times t + 41.28 \text{ mm}$$

From Table 9.5, we find that for 2 rivets per pitch length, the value of C is 2.62.

$$\therefore p_{max} = 2.62 \times 13 + 41.28 = 75.28 \text{ mm}$$

Since p_{max} is more than p , therefore we shall adopt

$$p = 71 \text{ mm} \quad \text{Ans.}$$

3. Distance between the rows of rivets

We know that the distance between the rows of rivets (for zig-zag riveting),

$$p_b = 0.33 p + 0.67 d = 0.33 \times 71 + 0.67 \times 23 \text{ mm}$$

$$= 38.8 \text{ say } 40 \text{ mm} \quad \text{Ans.}$$

4. Margin

We know that the margin,

$$m = 1.5 d = 1.5 \times 23 = 34.5 \text{ say } 35 \text{ mm} \quad \text{Ans.}$$

Failure of the joint

Now let us find the tearing resistance of the plate, shearing resistance and crushing resistance of the rivets.

We know that tearing resistance of the plate,

$$P_t = (p - d) t \times \sigma_t = (71 - 23) 13 \times 80 = 49\,920 \text{ N}$$

Shearing resistance of the rivets,

$$P_s = n \times \frac{\pi}{4} \times d^2 \times \tau = 2 \times \frac{\pi}{4} (23)^2 60 = 49\,864 \text{ N}$$

and crushing resistance of the rivets,

$$P_c = n \times d \times t \times \sigma_c = 2 \times 23 \times 13 \times 120 = 71\,760 \text{ N}$$

The least of P_t , P_s and P_c is $P_s = 49\,864 \text{ N}$. Hence the joint will fail due to shearing of the rivets. **Ans.**

Efficiency of the joint

We know that strength of the unriveted or solid plate,

$$P = p \times t \times \sigma_t = 71 \times 13 \times 80 = 73\,840 \text{ N}$$

\therefore Efficiency of the joint,

$$\eta = \frac{P_s}{P} = \frac{49\,864}{73\,840} = 0.675 \text{ or } 67.5\% \quad \text{Ans.}$$

Example 9.5. Two plates of 7 mm thick are connected by a triple riveted lap joint of zig-zag pattern. Calculate the rivet diameter, rivet pitch and distance between rows of rivets for the joint. Also state the mode of failure of the joint. The safe working stresses are as follows :

$$\sigma_t = 90 \text{ MPa} ; \tau = 60 \text{ MPa} ; \text{ and } \sigma_c = 120 \text{ MPa}.$$

Solution. Given : $t = 7 \text{ mm} ; \sigma_t = 90 \text{ MPa} = 90 \text{ N/mm}^2 ; \tau = 60 \text{ MPa} = 60 \text{ N/mm}^2 ; \sigma_c = 120 \text{ MPa} = 120 \text{ N/mm}^2$

1. Diameter of rivet

Since the thickness of plate is less than 8 mm, therefore diameter of the rivet hole (d) is obtained by equating the shearing resistance (P_s) to the crushing resistance (P_c) of the rivets. The triple riveted lap joint of zig-zag pattern is shown in Fig. 9.7 (b). We see that there are three rivets per pitch length (*i.e.* $n = 3$). Also, the rivets in lap joint are in single shear.

We know that shearing resistance of the rivets,

$$P_s = n \times \frac{\pi}{4} \times d^2 \times \tau$$

$$= 3 \times \frac{\pi}{4} \times d^2 \times 60 = 141.4 d^2 \text{ N} \dots(i)$$

...($\because n = 3$)

and crushing resistance of the rivets,

$$P_c = n \times d \times t \times \sigma_c = 3 \times d \times 7 \times 120 = 2520 d \text{ N} \dots(ii)$$

From equations (i) and (ii), we get

$$141.4 d^2 = 2520 d \text{ or } d = 2520 / 141.4 = 17.8 \text{ mm}$$

From Table 9.3, we see that according to IS : 1928 – 1961 (Reaffirmed 1996), the standard diameter of rivet hole (d) is 19 mm and the corresponding diameter of rivet is 18 mm. **Ans.**

2. Pitch of rivets

Let p = Pitch of rivets.

We know that tearing resistance of the plate,

$$P_t = (p - d) t \times \sigma_t = (p - 19) 7 \times 90 = 630 (p - 19) \text{ N} \dots(iii)$$

and shearing resistance of the rivets,

$$P_s = 141.4 d^2 = 141.4 (19)^2 = 51\,045 \text{ N} \dots[From equation (i)] \dots(iv)$$

Equating equations (iii) and (iv), we get

$$630 (p - 19) = 51\,045$$

$$p - 19 = 51\,045 / 630 = 81 \text{ or } p = 81 + 19 = 100 \text{ mm}$$



Forces on a ship as shown above need to be consider while designing various joints
 Note : This picture is given as additional information and is not a direct example of the current chapter.

304 ■ A Textbook of Machine Design

According to I.B.R., maximum pitch,

$$p_{max} = C.t + 41.28 \text{ mm}$$

From Table 9.5, we find that for lap joint and 3 rivets per pitch length, the value of C is 3.47.

$$\therefore p_{max} = 3.47 \times 7 + 41.28 = 65.57 \text{ say } 66 \text{ mm}$$

Since p_{max} is less than p , therefore we shall adopt $p = p_{max} = 66 \text{ mm}$ **Ans.**

3. Distance between rows of rivets

We know that the distance between the rows of rivets for zig-zag riveting,

$$p_b = 0.33 p + 0.67 d = 0.33 \times 66 + 0.67 \times 19 = 34.5 \text{ mm} \quad \text{Ans.}$$

Mode of failure of the joint

We know that tearing resistance of the plate,

$$P_t = (p - d) t \times \sigma_t = (66 - 19) 7 \times 90 = 29\,610 \text{ N}$$

Shearing resistance of rivets,

$$P_s = n \times \frac{\pi}{4} \times d^2 \times \tau = 3 \times \frac{\pi}{4} (19)^2 60 = 51\,045 \text{ N}$$

and crushing resistance of rivets.

$$P_c = n \times d \times t \times \sigma_c = 3 \times 19 \times 7 \times 120 = 47\,880 \text{ N}$$

From above we see that the least value of P_t , P_s and P_c is $P_t = 29\,610 \text{ N}$. Therefore the joint will fail due to tearing off the plate.

Example 9.6. Two plates of 10 mm thickness each are to be joined by means of a single riveted double strap butt joint. Determine the rivet diameter, rivet pitch, strap thickness and efficiency of the joint. Take the working stresses in tension and shearing as 80 MPa and 60 MPa respectively.

Solution. Given : $t = 10 \text{ mm}$; $\sigma_t = 80 \text{ MPa} = 80 \text{ N/mm}^2$; $\tau = 60 \text{ MPa} = 60 \text{ N/mm}^2$

1. Diameter of rivet

Since the thickness of plate is greater than 8 mm, therefore diameter of rivet hole,

$$d = 6\sqrt{t} = 6\sqrt{10} = 18.97 \text{ mm}$$

From Table 9.3, we see that according to IS : 1928 – 1961 (Reaffirmed 1996), the standard diameter of rivet hole (d) is 19 mm and the corresponding diameter of the rivet is 18 mm. **Ans.**

2. Pitch of rivets

Let $p =$ Pitch of rivets.

Since the joint is a single riveted double strap butt joint as shown in Fig. 9.8, therefore there is one rivet per pitch length (*i.e.* $n = 1$) and the rivets are in double shear.

We know that tearing resistance of the plate,

$$P_t = (p - d) t \times \sigma_t = (p - 19) 10 \times 80 = 800 (p - 19) \text{ N} \quad \dots(i)$$

and shearing resistance of the rivets,

$$\begin{aligned} P_s &= n \times 1.875 \times \frac{\pi}{4} \times d^2 \times \tau \quad \dots(\because \text{ Rivets are in double shear}) \\ &= 1 \times 1.875 \times \frac{\pi}{4} (19)^2 60 = 31\,900 \text{ N} \quad \dots(\because n = 1) \quad \dots(ii) \end{aligned}$$

From equations (i) and (ii), we get

$$800 (p - 19) = 31\,900$$

$$\therefore p - 19 = 31\,900 / 800 = 39.87 \text{ or } p = 39.87 + 19 = 58.87 \text{ say } 60 \text{ mm}$$

According to I.B.R., the maximum pitch of rivets,

$$p_{max} = C.t + 41.28 \text{ mm}$$

From Table 9.5, we find that for double strap butt joint and 1 rivet per pitch length, the value of C is 1.75.

$$\therefore p_{max} = 1.75 \times 10 + 41.28 = 58.78 \text{ say } 60 \text{ mm}$$

From above we see that $p = p_{max} = 60 \text{ mm}$ **Ans.**

3. Thickness of cover plates

We know that thickness of cover plates,

$$t_1 = 0.625 t = 0.625 \times 10 = 6.25 \text{ mm} \quad \text{Ans.}$$

Efficiency of the joint

We know that tearing resistance of the plate,

$$P_t = (p - d) t \times \sigma_t = (60 - 19) 10 \times 80 = 32\,800 \text{ N}$$

and shearing resistance of the rivets,

$$P_s = n \times 1.875 \times \frac{\pi}{4} \times d^2 \times \tau = 1 \times 1.875 \times \frac{\pi}{4} (19)^2 60 = 31\,900 \text{ N}$$

\therefore Strength of the joint

$$= \text{Least of } P_t \text{ and } P_s = 31\,900 \text{ N}$$

Strength of the unriveted plate per pitch length

$$P = p \times t \times \sigma_t = 60 \times 10 \times 80 = 48\,000 \text{ N}$$

\therefore Efficiency of the joint,

$$\eta = \frac{\text{Least of } P_t \text{ and } P_s}{P} = \frac{31\,900}{48\,000} = 0.665 \text{ or } 66.5\% \quad \text{Ans.}$$

Example 9.7. Design a double riveted butt joint with two cover plates for the longitudinal seam of a boiler shell 1.5 m in diameter subjected to a steam pressure of 0.95 N/mm². Assume joint efficiency as 75%, allowable tensile stress in the plate 90 MPa; compressive stress 140 MPa; and shear stress in the rivet 56 MPa.

Solution. Given : $D = 1.5 \text{ m} = 1500 \text{ mm}$; $P = 0.95 \text{ N/mm}^2$; $\eta_l = 75\% = 0.75$; $\sigma_t = 90 \text{ MPa} = 90 \text{ N/mm}^2$; $\sigma_c = 140 \text{ MPa} = 140 \text{ N/mm}^2$; $\tau = 56 \text{ MPa} = 56 \text{ N/mm}^2$

1. Thickness of boiler shell plate

We know that thickness of boiler shell plate,

$$t = \frac{P.D}{2\sigma_t \times \eta_l} + 1 \text{ mm} = \frac{0.95 \times 1500}{2 \times 90 \times 0.75} + 1 = 11.6 \text{ say } 12 \text{ mm} \quad \text{Ans.}$$

2. Diameter of rivet

Since the thickness of the plate is greater than 8 mm, therefore the diameter of the rivet hole,

$$d = 6\sqrt{t} = 6\sqrt{12} = 20.8 \text{ mm}$$

From Table 9.3, we see that according to IS : 1928 – 1961 (Reaffirmed 1996), the standard diameter of the rivet hole (d) is 21 mm and the corresponding diameter of the rivet is 20 mm. **Ans.**

3. Pitch of rivets

Let p = Pitch of rivets.

The pitch of the rivets is obtained by equating the tearing resistance of the plate to the shearing resistance of the rivets.

We know that tearing resistance of the plate,

$$P_t = (p - d) t \times \sigma_t = (p - 21) 12 \times 90 = 1080 (p - 21) \text{ N} \quad \dots(i)$$

Since the joint is double riveted double strap butt joint, as shown in Fig. 9.9, therefore there are two rivets per pitch length (*i.e.* $n = 2$) and the rivets are in double shear. Assuming that the rivets in

306 ■ A Textbook of Machine Design

double shear are 1.875 times stronger than in single shear, we have

Shearing strength of the rivets,

$$P_s = n \times 1.875 \times \frac{\pi}{4} \times d^2 \times \tau = 2 \times 1.875 \times \frac{\pi}{4} (21)^2 \times 56 \text{ N}$$

$$= 72\,745 \text{ N} \quad \dots(ii)$$

From equations (i) and (ii), we get

$$1080 (p - 21) = 72\,745$$

$$\therefore p - 21 = 72\,745 / 1080 = 67.35 \text{ or } p = 67.35 + 21 = 88.35 \text{ say } 90 \text{ mm}$$

According to I.B.R., the maximum pitch of rivets for longitudinal joint of a boiler is given by

$$p_{max} = C \times t + 41.28 \text{ mm}$$

From Table 9.5, we find that for a double riveted double strap butt joint and two rivets per pitch length, the value of C is 3.50.

$$\therefore p_{max} = 3.5 \times 12 + 41.28 = 83.28 \text{ say } 84 \text{ mm}$$

Since the value of p is more than p_{max} , therefore we shall adopt pitch of the rivets,

$$p = p_{max} = 84 \text{ mm} \quad \text{Ans.}$$

4. Distance between rows of rivets

Assuming zig-zag riveting, the distance between the rows of the rivets (according to I.B.R.),

$$p_b = 0.33 p + 0.67 d = 0.33 \times 84 + 0.67 \times 21 = 41.8 \text{ say } 42 \text{ mm} \quad \text{Ans.}$$

5. Thickness of cover plates

According to I.B.R., the thickness of each cover plate of equal width is

$$t_1 = 0.625 t = 0.625 \times 12 = 7.5 \text{ mm} \quad \text{Ans.}$$

6. Margin

We know that the margin,

$$m = 1.5 d = 1.5 \times 21 = 31.5 \text{ say } 32 \text{ mm} \quad \text{Ans.}$$

Let us now find the efficiency for the designed joint.

Tearing resistance of the plate,

$$P_t = (p - d) t \times \sigma_t = (84 - 21) 12 \times 90 = 68\,040 \text{ N}$$

Shearing resistance of the rivets,

$$P_s = n \times 1.875 \times \frac{\pi}{4} \times d^2 \times \tau = 2 \times 1.875 \times \frac{\pi}{4} (21)^2 \times 56 = 72\,745 \text{ N}$$

and crushing resistance of the rivets,

$$P_c = n \times d \times t \times \sigma_c = 2 \times 21 \times 12 \times 140 = 70\,560 \text{ N}$$

Since the strength of riveted joint is the least value of P_t , P_s or P_c , therefore strength of the riveted joint,

$$P_t = 68\,040 \text{ N}$$

We know that strength of the un-riveted plate,

$$P = p \times t \times \sigma_t = 84 \times 12 \times 90 = 90\,720 \text{ N}$$

\therefore Efficiency of the designed joint,

$$\eta = \frac{P_t}{P} = \frac{68\,040}{90\,720} = 0.75 \text{ or } 75\% \quad \text{Ans.}$$

Since the efficiency of the designed joint is equal to the given efficiency of 75%, therefore the design is satisfactory.

Example 9.8. A pressure vessel has an internal diameter of 1 m and is to be subjected to an internal pressure of 2.75 N/mm^2 above the atmospheric pressure. Considering it as a thin cylinder and assuming efficiency of its riveted joint to be 79%, calculate the plate thickness if the tensile stress in the material is not to exceed 88 MPa.

Design a longitudinal double riveted double strap butt joint with equal straps for this vessel. The pitch of the rivets in the outer row is to be double the pitch in the inner row and zig-zag riveting is proposed. The maximum allowable shear stress in the rivets is 64 MPa. You may assume that the rivets in double shear are 1.8 times stronger than in single shear and the joint does not fail by crushing.

Make a sketch of the joint showing all calculated values. Calculate the efficiency of the joint.

Solution. Given : $D = 1 \text{ m} = 1000 \text{ mm}$; $P = 2.75 \text{ N/mm}^2$; $\eta_l = 79\% = 0.79$; $\sigma_t = 88 \text{ MPa} = 88 \text{ N/mm}^2$; $\tau = 64 \text{ MPa} = 64 \text{ N/mm}^2$

1. Thickness of plate

We know that the thickness of plate,

$$t = \frac{P.D}{2 \sigma_t \times \eta_l} + 1 \text{ mm} = \frac{2.75 \times 1000}{2 \times 88 \times 0.79} + 1 \text{ mm} = 20.8 \text{ say } 21 \text{ mm} \quad \text{Ans.}$$

2. Diameter of rivet

Since the thickness of plate is more than 8 mm, therefore diameter of rivet hole,

$$d = 6\sqrt{t} = 6\sqrt{21} = 27.5 \text{ mm}$$

From Table 9.3, we see that according to IS : 1928 – 1961 (Reaffirmed 1996), the standard diameter of the rivet hole (d) is 28.5 mm and the corresponding diameter of the rivet is 27 mm. **Ans.**

3. Pitch of rivets

Let p = Pitch in the outer row.

The pitch of the rivets is obtained by equating the tearing resistance of the plate to the shearing resistance of the rivets.

We know that the tearing resistance of the plate per pitch length,

$$P_t = (p - d) t \times \sigma_t = (p - 28.5) 21 \times 88 = 1848 (p - 28.5) \text{ N} \quad \dots(i)$$

Since the pitch in the outer row is twice the pitch of the inner row and the joint is double riveted, therefore for one pitch length there will be three rivets in double shear (*i.e.* $n = 3$). It is given that the strength of rivets in double shear is 1.8 times that of single shear, therefore

Shearing strength of the rivets per pitch length,

$$P_s = n \times 1.8 \times \frac{\pi}{4} \times d^2 \times \tau = 3 \times 1.8 \times \frac{\pi}{4} (28.5)^2 64 \text{ N} = 220\,500 \text{ N} \quad \dots(ii)$$

From equations (i) and (ii), we get

$$1848 (p - 28.5) = 220\,500$$

$$\therefore p - 28.5 = 220\,500 / 1848 = 119.3$$

or $p = 119.3 + 28.5 = 147.8 \text{ mm}$



Pressure vessel.

308 ■ A Textbook of Machine Design

According to I.B.R., the maximum pitch,

$$p_{max} = C \times t + 41.28 \text{ mm}$$

From Table 9.5, we find that for 3 rivets per pitch length and for double strap butt joint, the value of C is 4.63.

$$\therefore p_{max} = 4.63 \times 21 + 41.28 = 138.5 \text{ say } 140 \text{ mm}$$

Since the value of p_{max} is less than p , therefore we shall adopt the value of

$$p = p_{max} = 140 \text{ mm} \quad \text{Ans.}$$

\therefore Pitch in the inner row

$$= 140 / 2 = 70 \text{ mm} \quad \text{Ans.}$$

4. Distance between the rows of rivets

According to I.B.R., the distance between the rows of rivets,

$$p_b = 0.2 p + 1.15 d = 0.2 \times 140 + 1.15 \times 28.5 = 61 \text{ mm} \quad \text{Ans.}$$

5. Thickness of butt strap

According to I.B.R., the thickness of double butt straps of equal width,

$$t_1 = 0.625 t \left(\frac{p - d}{p - 2d} \right) = 0.625 \times 21 \left(\frac{140 - 28.5}{140 - 2 \times 28.5} \right) \text{ mm}$$

$$= 17.6 \text{ say } 18 \text{ mm} \quad \text{Ans.}$$

6. Margin

We know that the margin,

$$m = 1.5 d = 1.5 \times 28.5 = 43 \text{ mm} \quad \text{Ans.}$$

Efficiency of the joint

We know that tearing resistance of the plate,

$$P_t = (p - d) t \times \sigma_t = (140 - 28.5) 21 \times 88 = 206\,050 \text{ N}$$

Shearing resistance of the rivets,

$$P_s = n \times 1.8 \times \frac{\pi}{4} \times d^2 \times \tau = 3 \times 1.8 \times \frac{\pi}{4} (28.5)^2 64 = 220\,500 \text{ N}$$

Strength of the solid plate,

$$= p \times t \times \sigma_t = 140 \times 21 \times 88 = 258\,720 \text{ N}$$

\therefore Efficiency of the joint

$$= \frac{\text{Least of } P_t \text{ and } P_s}{\text{Strength of solid plate}} = \frac{206\,050}{258\,720} = 0.796 \text{ or } 79.6\% \quad \text{Ans.}$$

Since the efficiency of the designed joint is more than the given efficiency, therefore the design is satisfactory.

Example 9.9. Design the longitudinal joint for a 1.25 m diameter steam boiler to carry a steam pressure of 2.5 N/mm². The ultimate strength of the boiler plate may be assumed as 420 MPa, crushing strength as 650 MPa and shear strength as 300 MPa. Take the joint efficiency as 80%. Sketch the joint with all the dimensions. Adopt the suitable factor of safety.

Solution. Given : $D = 1.25 \text{ m} = 1250 \text{ mm}$; $P = 2.5 \text{ N/mm}^2$; $\sigma_{tu} = 420 \text{ MPa} = 420 \text{ N/mm}^2$; $\sigma_{cu} = 650 \text{ MPa} = 650 \text{ N/mm}^2$; $\tau_u = 300 \text{ MPa} = 300 \text{ N/mm}^2$; $\eta_j = 80\% = 0.8$

Assuming a factor of safety ($F.S.$) as 5, the allowable stresses are as follows :

$$\sigma_t = \frac{\sigma_{tu}}{F.S.} = \frac{420}{5} = 84 \text{ N/mm}^2$$

$$\sigma_c = \frac{\sigma_{cu}}{F.S.} = \frac{650}{5} = 130 \text{ N/mm}^2$$

and

$$\tau = \frac{\tau_u}{F.S.} = \frac{300}{5} = 60 \text{ N/mm}^2$$

1. Thickness of plate

We know that thickness of plate,

$$\begin{aligned} t &= \frac{P.D}{2 \sigma_t \times \eta_t} + 1 \text{ mm} = \frac{2.5 \times 1250}{2 \times 84 \times 0.8} + 1 \text{ mm} \\ &= 24.3 \text{ say } 25 \text{ mm} \quad \text{Ans.} \end{aligned}$$

2. Diameter of rivet

Since the thickness of the plate is more than 8 mm, therefore diameter of the rivet hole,

$$d = 6\sqrt{t} = 6\sqrt{25} = 30 \text{ mm}$$

From Table 9.3, we see that according to IS : 1928 – 1961 (Reaffirmed 1996), the standard diameter of the rivet hole is 31.5 mm and the corresponding diameter of the rivet is 30 mm. **Ans.**

3. Pitch of rivets

Assume a triple riveted double strap butt joint with unequal straps, as shown in Fig. 9.11.

Let p = Pitch of the rivets in the outer most row.

∴ Tearing strength of the plate per pitch length,

$$P_t = (p - d) t \times \sigma_t = (p - 31.5) 25 \times 84 = 2100 (p - 31.5) \text{ N} \quad \dots(i)$$

Since the joint is triple riveted with two unequal cover straps, therefore there are 5 rivets per pitch length. Out of these five rivets, four rivets are in double shear and one is in single shear. Assuming the strength of the rivets in double shear as 1.875 times that of single shear, therefore

Shearing resistance of the rivets per pitch length,

$$\begin{aligned} P_s &= 4 \times 1.875 \times \frac{\pi}{4} \times d^2 \times \tau + \frac{\pi}{4} \times d^2 \times \tau = 8.5 \times \frac{\pi}{4} \times d^2 \times \tau \\ &= 8.5 \times \frac{\pi}{4} (31.5)^2 60 = 397\,500 \text{ N} \quad \dots(ii) \end{aligned}$$

From equations (i) and (ii), we get

$$2100 (p - 31.5) = 397\,500$$

∴ $p - 31.5 = 397\,500 / 2100 = 189.3$ or $p = 31.5 + 189.3 = 220.8 \text{ mm}$

According to I.B.R., maximum pitch,

$$p_{max} = C \times t + 41.28 \text{ mm}$$

From Table 9.5, we find that for double strap butt joint with 5 rivets per pitch length, the value of C is 6.

∴ $p_{max} = 6 \times 25 + 41.28 = 191.28$ say 196 mm **Ans.**

Since p_{max} is less than p , therefore we shall adopt $p = p_{max} = 196 \text{ mm}$ **Ans.**

∴ Pitch of rivets in the inner row,

$$p' = 196 / 2 = 98 \text{ mm} \quad \text{Ans.}$$

4. Distance between the rows of rivets

According to I.B.R., the distance between the outer row and the next row,

$$\begin{aligned} &= 0.2 p + 1.15 d = 0.2 \times 196 + 1.15 \times 31.5 \text{ mm} \\ &= 75.4 \text{ say } 76 \text{ mm} \quad \text{Ans.} \end{aligned}$$

and the distance between the inner rows for zig-zag riveting

$$\begin{aligned} &= 0.165 p + 0.67 d = 0.165 \times 196 + 0.67 \times 31.5 \text{ mm} \\ &= 53.4 \text{ say } 54 \text{ mm} \quad \text{Ans.} \end{aligned}$$

5. Thickness of butt straps

We know that for unequal width of butt straps, the thicknesses are as follows :

For wide butt strap, $t_1 = 0.75 t = 0.75 \times 25 = 18.75$ say 20 mm **Ans.**
 and for narrow butt strap, $t_2 = 0.625 t = 0.625 \times 25 = 15.6$ say 16 mm **Ans.**

It may be noted that wide and narrow butt straps are placed on the inside and outside of the shell respectively.

6. Margin

We know that the margin,

$$m = 1.5 d = 1.5 \times 31.5 = 47.25 \text{ say } 47.5 \text{ mm} \quad \text{Ans.}$$

Let us now check the efficiency of the designed joint.

Tearing resistance of the plate in the outer row,

$$P_t = (p - d) t \times \sigma_t = (196 - 31.5) 25 \times 84 = 345\,450 \text{ N}$$

Shearing resistance of the rivets,

$$\begin{aligned} P_s &= 4 \times 1.875 \times \frac{\pi}{4} \times d^2 \times \tau + \frac{\pi}{4} \times d^2 \times \tau = 8.5 \times \frac{\pi}{4} \times d^2 \times \tau \\ &= 8.5 \times \frac{\pi}{4} (31.5)^2 \times 60 = 397\,500 \text{ N} \end{aligned}$$

and crushing resistance of the rivets,

$$P_c = n \times d \times t \times \sigma_c = 5 \times 31.5 \times 25 \times 130 = 511\,875 \text{ N} \quad \dots (\because n = 5)$$

The joint may also fail by tearing off the plate between the rivets in the second row. This is only possible if the rivets in the outermost row gives way (*i.e.* shears). Since there are two rivet holes per pitch length in the second row and one rivet is in the outer most row, therefore combined tearing and shearing resistance

$$\begin{aligned} &= (p - 2d) t \times \sigma_t + \frac{\pi}{4} \times d^2 \times \tau \\ &= (196 - 2 \times 31.5) 25 \times 84 + \frac{\pi}{4} (31.5)^2 60 = 326\,065 \text{ N} \end{aligned}$$

From above, we see that strength of the joint

$$= 326\,065 \text{ N}$$

Strength of the unriveted or solid plate,

$$P = p \times t \times \sigma_t = 196 \times 25 \times 84 = 411\,600 \text{ N}$$

∴ Efficiency of the joint,

$$\eta = 326\,065 / 411\,600 = 0.792 \text{ or } 79.2\%$$

Since the efficiency of the designed joint is nearly equal to the given efficiency, therefore the design is satisfactory.

Example 9.10. A steam boiler is to be designed for a working pressure of 2.5 N/mm² with its inside diameter 1.6 m. Give the design calculations for the longitudinal and circumferential joints for the following working stresses for steel plates and rivets :

In tension = 75 MPa ; In shear = 60 MPa; In crushing = 125 MPa.

Draw the joints to a suitable scale.

Solution. Given : $P = 2.5 \text{ N/mm}^2$; $D = 1.6 \text{ m} = 1600 \text{ mm}$; $\sigma_t = 75 \text{ MPa} = 75 \text{ N/mm}^2$; $\tau = 60 \text{ MPa} = 60 \text{ N/mm}^2$; $\sigma_c = 125 \text{ MPa} = 125 \text{ N/mm}^2$

Design of longitudinal joint

The longitudinal joint for a steam boiler may be designed as follows :

1. Thickness of boiler shell

We know that the thickness of boiler shell,

$$\begin{aligned} t &= \frac{P.D}{2 \sigma_t} + 1 \text{ mm} = \frac{2.5 \times 1600}{2 \times 75} + 1 \text{ mm} \\ &= 27.6 \text{ say } 28 \text{ mm} \quad \text{Ans.} \end{aligned}$$

2. Diameter of rivet

Since the thickness of the plate is more than 8 mm, therefore diameter of rivet hole,

$$d = 6\sqrt{t} = 6\sqrt{28} = 31.75 \text{ mm}$$

From Table 9.3, we see that according to IS : 1928 – 1961 (Reaffirmed 1996), the standard diameter of rivet hole (d) is 34.5 mm and the corresponding diameter of the rivet is 33 mm. **Ans.**

3. Pitch of rivets

Assume the joint to be triple riveted double strap butt joint with unequal cover straps, as shown in Fig. 9.11.

Let p = Pitch of the rivet in the outer most row.

∴ Tearing resistance of the plate per pitch length,

$$\begin{aligned} P_t &= (p - d) t \times \sigma_t = (p - 34.5) 28 \times 75 \text{ N} \\ &= 2100 (p - 34.5) \text{ N} \quad \dots(i) \end{aligned}$$

Since the joint is triple riveted with two unequal cover straps, therefore there are 5 rivets per pitch length. Out of these five rivets, four are in double shear and one is in single shear. Assuming the strength of rivets in double shear as 1.875 times that of single shear, therefore

Shearing resistance of the rivets per pitch length,

$$\begin{aligned} P_s &= 4 \times 1.875 \times \frac{\pi}{4} \times d^2 \times \tau + \frac{\pi}{4} \times d^2 \times \tau \\ &= 8.5 \times \frac{\pi}{4} \times d^2 \times \tau \\ &= 8.5 \times \frac{\pi}{4} (34.5)^2 \times 60 = 476\,820 \text{ N} \quad \dots(ii) \end{aligned}$$

Equating equations (i) and (ii), we get

$$2100 (p - 34.5) = 476\,820$$

$$\therefore p - 34.5 = 476\,820 / 2100 = 227 \text{ or } p = 227 + 34.5 = 261.5 \text{ mm}$$

According to I.B.R., the maximum pitch,

$$p_{max} = C.t + 41.28 \text{ mm}$$

From Table 9.5, we find that for double strap butt joint with 5 rivets per pitch length, the value of C is 6.

$$\therefore p_{max} = 6 \times 28 + 41.28 = 209.28 \text{ say } 220 \text{ mm}$$

Since p_{max} is less than p , therefore we shall adopt

$$p = p_{max} = 220 \text{ mm} \quad \text{Ans.}$$

∴ Pitch of rivets in the inner row,

$$p' = 220 / 2 = 110 \text{ mm} \quad \text{Ans.}$$

4. Distance between the rows of rivets

According to I.B.R., the distance between the outer row and the next row

$$\begin{aligned} &= 0.2 p + 1.15 d = 0.2 \times 220 + 1.15 \times 34.5 \text{ mm} \\ &= 83.7 \text{ say } 85 \text{ mm} \quad \text{Ans.} \end{aligned}$$

312 ■ A Textbook of Machine Design

and the distance between the inner rows for zig-zig riveting

$$\begin{aligned} &= 0.165 p + 0.67 d = 0.165 \times 220 + 0.67 \times 34.5 \text{ mm} \\ &= 59.4 \text{ say } 60 \text{ mm} \quad \text{Ans.} \end{aligned}$$

5. Thickness of butt straps

We know that for unequal width of butt straps, the thicknesses are :

$$\text{For wide butt strap, } t_1 = 0.75 t = 0.75 \times 28 = 21 \text{ mm} \quad \text{Ans.}$$

$$\text{and for narrow butt strap, } t_2 = 0.625 t = 0.625 \times 28 = 17.5 \text{ say } 18 \text{ mm} \quad \text{Ans.}$$

It may be noted that the wide and narrow butt straps are placed on the inside and outside of the shell respectively.

6. Margin

We know that the margin,

$$m = 1.5 d = 1.5 \times 34.5 = 51.75 \text{ say } 52 \text{ mm} \quad \text{Ans.}$$

Let us now check the efficiency of the designed joint.

Tearing resistance of the plate in the outer row,

$$P_t = (p - d) t \times \sigma_t = (220 - 34.5) 28 \times 75 = 389\,550 \text{ N}$$

Shearing resistance of the rivets,

$$\begin{aligned} P_s &= 4 \times 1.875 \times \frac{\pi}{4} \times d^2 \times \tau + \frac{\pi}{4} \times d^2 \times \tau = 8.5 \times \frac{\pi}{4} \times d^2 \times \tau \\ &= 8.5 \times \frac{\pi}{4} (34.5)^2 \times 60 = 476\,820 \text{ N} \end{aligned}$$

and crushing resistance of the rivets,

$$P_c = n \times d \times t \times \sigma_c = 5 \times 34.5 \times 28 \times 125 = 603\,750 \text{ N}$$

The joint may also fail by tearing off the plate between the rivets in the second row. This is only possible if the rivets in the outermost row gives way (*i.e.* shears). Since there are two rivet holes per pitch length in the second row and one rivet in the outermost row, therefore

Combined tearing and shearing resistance

$$\begin{aligned} &= (p - 2d) t \times \sigma_t + \frac{\pi}{4} \times d^2 \times \tau \\ &= (220 - 2 \times 34.5) 28 \times 75 + \frac{\pi}{4} (34.5)^2 \times 60 \\ &= 317\,100 + 56\,096 = 373\,196 \text{ N} \end{aligned}$$

From above, we see that the strength of the joint

$$= 373\,196 \text{ N}$$

Strength of the unriveted or solid plate,

$$P = p \times t \times \sigma_t = 220 \times 28 \times 75 = 462\,000 \text{ N}$$

∴ Efficiency of the designed joint,

$$\eta = \frac{373\,196}{462\,000} = 0.808 \text{ or } 80.8\% \quad \text{Ans.}$$

Design of circumferential joint

The circumferential joint for a steam boiler may be designed as follows :

1. The thickness of the boiler shell (t) and diameter of rivet hole (d) will be same as for longitudinal joint, *i.e.*

$$t = 28 \text{ mm ; and } d = 34.5 \text{ mm}$$

2. Number of rivets

Let n = Number of rivets.

We know that shearing resistance of the rivets

$$= n \times \frac{\pi}{4} \times d^2 \times \tau \quad \dots(i)$$

and total shearing load acting on the circumferential joint

$$= \frac{\pi}{4} \times D^2 \times P \quad \dots(ii)$$

From equations (i) and (ii), we get

$$n \times \frac{\pi}{4} \times d^2 \times \tau = \frac{\pi}{4} \times D^2 \times P$$

$$\therefore n = \frac{D^2 \times P}{d^2 \times \tau} = \frac{(1600)^2 \times 2.5}{(34.5)^2 \times 60} = 89.6 \text{ say } 90 \quad \text{Ans.}$$

3. Pitch of rivets

Assuming the joint to be double riveted lap joint with zig-zag riveting, therefore number of rivets per row

$$= 90 / 2 = 45$$

We know that the pitch of the rivets,

$$p_1 = \frac{\pi (D + t)}{\text{Number of rivets per row}} = \frac{\pi (1600 + 28)}{45} = 113.7 \text{ mm}$$

Let us take pitch of the rivets, $p_1 = 140 \text{ mm}$ **Ans.**

4. Efficiency of the joint

We know that the efficiency of the circumferential joint,

$$\eta_c = \frac{p_1 - d}{p_1} = \frac{140 - 34.5}{140} = 0.753 \text{ or } 75.3\%$$

5. Distance between the rows of rivets

We know that the distance between the rows of rivets for zig-zag riveting,

$$= 0.33 p_1 + 0.67 d = 0.33 \times 140 + 0.67 \times 34.5 \text{ mm}$$

$$= 69.3 \text{ say } 70 \text{ mm} \quad \text{Ans.}$$

6. Margin

We know that the margin,

$$m = 1.5 d = 1.5 \times 34.5$$

$$= 51.75 \text{ say } 52 \text{ mm} \quad \text{Ans.}$$

9.20 Riveted Joint for Structural Use—Joints of Uniform Strength (Lozenge Joint)

A riveted joint known as *Lozenge joint* used for roof, bridge work or girders etc. is shown in Fig. 9.19. In such a joint, *diamond riveting is employed so that the joint is made of uniform strength.

Fig. 9.19 shows a triple riveted double strap butt joint.



Riveted joints are used for roofs, bridge work and girders.

* In diamond riveting, the number of rivets increases as we proceed from the outermost row to the innermost row.

314 ■ A Textbook of Machine Design

Let b = Width of the plate,
 t = Thickness of the plate, and
 d = Diameter of the rivet hole.

In designing a Lozenge joint, the following procedure is adopted.

1. Diameter of rivet

The diameter of the rivet hole is obtained by using Unwin's formula, *i.e.*

$$d = 6\sqrt{t}$$

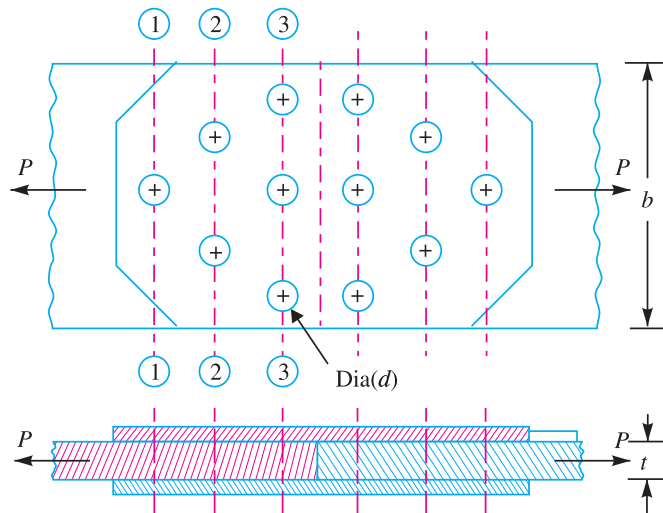

Fig. 9.19. Riveted joint for structural use.

According to IS : 1929–1982 (Reaffirmed 1996), the sizes of rivets for general purposes are given in the following table.

Table 9.7. Sizes of rivets for general purposes, according to IS : 1929 – 1982 (Reaffirmed 1996).

Diameter of rivet hole (mm)	13.5	15.5	17.5	19.5	21.5	23.5	25.5	29	32	35	38	41	44	50
Diameter of rivet (mm)	12	14	16	18	20	22	24	27	30	33	36	39	42	48

2. Number of rivets

The number of rivets required for the joint may be obtained by the shearing or crushing resistance of the rivets.

Let P_t = Maximum pull acting on the joint. This is the tearing resistance of the plate at the outer row which has only one rivet.
 $= (b - d) t \times \sigma_t$

and

n = Number of rivets.

Since the joint is double strap butt joint, therefore the rivets are in double shear. It is assumed that resistance of a rivet in double shear is 1.75 times than in single shear in order to allow for possible eccentricity of load and defective workmanship.

∴ Shearing resistance of one rivet,

$$P_s = 1.75 \times \frac{\pi}{4} \times d^2 \times \tau$$

and crushing resistance of one rivet,

$$P_c = d \times t \times \sigma_c$$

∴ Number of rivets required for the joint,

$$n = \frac{P_t}{\text{Least of } P_s \text{ or } P_c}$$

3. From the number of rivets, the number of rows and the number of rivets in each row is decided.

4. Thickness of the butt straps

The thickness of the butt strap,

$$\begin{aligned} t_1 &= 1.25 t, \text{ for single cover strap} \\ &= 0.75 t, \text{ for double cover strap} \end{aligned}$$

5. Efficiency of the joint

First of all, calculate the resistances along the sections 1-1, 2-2 and 3-3.

At section 1-1, there is only one rivet hole.

∴ Resistance of the joint in tearing along 1-1,

$$P_{t1} = (b - d) t \times \sigma_t$$

At section 2-2, there are two rivet holes.

∴ Resistance of the joint in tearing along 2-2,

$$P_{t2} = (b - 2d) t \times \sigma_t + \text{Strength of one rivet in front of section 2-2}$$

(This is due to the fact that for tearing off the plate at section 2-2, the rivet in front of section 2-2 *i.e.* at section 1-1 must first fracture).

Similarly at section 3-3 there are three rivet holes.

∴ Resistance of the joint in tearing along 3-3,

$$P_{t3} = (b - 3d) t \times \sigma_t + \text{Strength of 3 rivets in front of section 3-3}$$

The least value of P_{t1} , P_{t2} , P_{t3} , P_s or P_c is the strength of the joint.

We know that the strength of unriveted plate,

$$P = b \times t \times \sigma_t$$

∴ Efficiency of the joint,

$$\eta = \frac{\text{Least of } P_{t1}, P_{t2}, P_{t3}, P_s \text{ or } P_c}{P}$$

Note : The permissible stresses employed in structural joints are higher than those used in design of pressure vessels. The following values are usually adopted.

For plates in tension	... 140 MPa
For rivets in shear	... 105 MPa
For crushing of rivets and plates	
Single shear	... 224 MPa
Double shear	... 280 MPa

6. The pitch of the rivets is obtained by equating the strength of the joint in tension to the strength of the rivets in shear. The pitches allowed in structural joints are larger than those of pressure vessels. The following table shows the values of pitch due to Rotscher.

Table 9.8. Pitch of rivets for structural joints.

Thickness of plate (mm)	Diameter of rivet hole (mm)	Diameter of rivet (mm)	Pitch of rivet $p = 3d + 5\text{mm}$	Marginal pitch (mm)
2	8.4	8	29	16
3	9.5	9	32	17
4	11	10	35	17
5–6	13	12	38	18
6–8	15	14	47	21
8–12	17	16	56	25
11–15	21	20	65	30

7. The marginal pitch (m) should not be less than $1.5 d$.

8. The distance between the rows of rivets is $2.5 d$ to $3 d$.

Example 9.11. Two lengths of mild steel tie rod having width 200 mm and thickness 12.5 mm are to be connected by means of a butt joint with double cover plates. Design the joint if the permissible stresses are 80 MPa in tension, 65 MPa in shear and 160 MPa in crushing. Make a sketch of the joint.

Solution. Given : $b = 200 \text{ mm}$; $t = 12.5 \text{ mm}$; $\sigma_t = 80 \text{ MPa} = 80 \text{ N/mm}^2$; $\tau = 65 \text{ MPa} = 65 \text{ N/mm}^2$; $\sigma_c = 160 \text{ MPa} = 160 \text{ N/mm}^2$

1. Diameter of rivet

We know that the diameter of rivet hole,

$$d = 6\sqrt{t} = 6\sqrt{12.5} = 21.2 \text{ mm}$$

From Table 9.7, we see that according to IS : 1929 – 1982 (Reaffirmed 1996), the standard diameter of the rivet hole (d) is 21.5 mm and the corresponding diameter of rivet is 20 mm. **Ans.**

2. Number of rivets

Let n = Number of rivets.

We know that maximum pull acting on the joint,

$$P_t = (b - d) t \times \sigma_t = (200 - 21.5) 12.5 \times 80 = 178\,500 \text{ N}$$

Since the joint is a butt joint with double cover plates as shown in Fig. 9.20, therefore the rivets are in double shear. Assume that the resistance of the rivet in double shear is 1.75 times than in single shear.

∴ Shearing resistance of one rivet,

$$P_s = 1.75 \times \frac{\pi}{4} \times d^2 \times \tau = 1.75 \times \frac{\pi}{4} (21.5)^2 65 = 41\,300 \text{ N}$$

and crushing resistance of one rivet,

$$P_c = d \times t \times \sigma_c = 21.5 \times 12.5 \times 160 = 43\,000 \text{ N}$$

Since the shearing resistance is less than the crushing resistance, therefore number of rivets required for the joint,

$$n = \frac{P_t}{P_s} = \frac{178\,500}{41\,300} = 4.32 \text{ say } 5 \quad \text{Ans.}$$

3. The arrangement of the rivets is shown in Fig. 9.20.

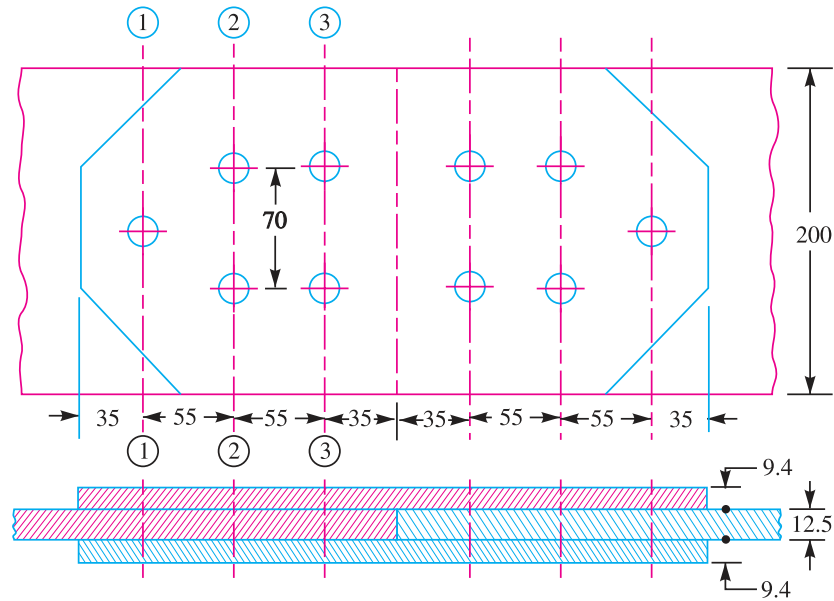

Fig. 9.20. All dimensions in mm.

4. Thickness of butt straps

We know that thickness of butt straps,

$$t_1 = 0.75 t = 0.75 \times 12.5 = 9.375 \text{ say } 9.4 \text{ mm} \quad \text{Ans.}$$

5. Efficiency of the joint

First of all, let us find the resistances along the sections 1-1, 2-2 and 3-3.

At section 1-1, there is only one rivet hole.

∴ Resistance of the joint in tearing along section 1-1,

$$P_{t1} = (b - d) t \times \sigma_t = (200 - 21.5) 12.5 \times 80 = 178\,500 \text{ N}$$

At section 2-2, there are two rivet holes. In this case, the tearing of the plate will only take place if the rivet at section 1-1 (in front of section 2-2) gives way (*i.e.* shears).

∴ Resistance of the joint in tearing along section 2-2,

$$\begin{aligned} P_{t2} &= (b - 2d) t \times \sigma_t + \text{Shearing resistance of one rivet} \\ &= (200 - 2 \times 21.5) 12.5 \times 80 + 41\,300 = 198\,300 \text{ N} \end{aligned}$$

At section 3-3, there are two rivet holes. The tearing of the plate will only take place if one rivet at section 1-1 and two rivets at section 2-2 gives way (*i.e.* shears).

∴ Resistance of the joint in tearing along section 3-3,

$$\begin{aligned} P_{t3} &= (b - 2d) t \times \sigma_t + \text{Shearing resistance of 3 rivets} \\ &= (200 - 2 \times 21.5) 12.5 \times 80 + 3 \times 41\,300 = 280\,900 \text{ N} \end{aligned}$$

Shearing resistance of all the 5 rivets

$$P_s = 5 \times 41\,300 = 206\,500 \text{ N}$$

and crushing resistance of all the 5 rivets,

$$P_c = 5 \times 43\,000 = 215\,000 \text{ N}$$

318 ■ A Textbook of Machine Design

Since the strength of the joint is the least value of P_{t1} , P_{t2} , P_{t3} , P_s and P_c , therefore strength of the joint

$$= 178\,500 \text{ N along section 1-1}$$

We know that strength of the un-riveted plate,

$$= b \times t \times \sigma_t = 20 \times 12.5 \times 80 = 200\,000 \text{ N}$$

∴ Efficiency of the joint,

$$\eta = \frac{\text{Strength of the joint}}{\text{Strength of the unriveted plate}} = \frac{178\,500}{200\,000} = 0.8925 \text{ or } 89.25\% \text{ Ans.}$$

6. Pitch of rivets, $p = 3d + 5 \text{ mm} = (3 \times 21.5) + 5 = 69.5 \text{ say } 70 \text{ mm Ans.}$

7. Marginal pitch, $m = 1.5d = 1.5 \times 21.5 = 33.25 \text{ say } 35 \text{ mm Ans.}$

8. Distance between the rows of rivets
 $= 2.5d = 2.5 \times 21.5 = 53.75 \text{ say } 55 \text{ mm Ans.}$

Example 9.12. A tie-bar in a bridge consists of flat 350 mm wide and 20 mm thick. It is connected to a gusset plate of the same thickness by a double cover butt joint. Design an economical joint if the permissible stresses are :

$$\sigma_t = 90 \text{ MPa}, \tau = 60 \text{ MPa and } \sigma_c = 150 \text{ MPa}$$

Solution. Given : $b = 350 \text{ mm}$; $t = 20 \text{ mm}$; $\sigma_t = 90 \text{ MPa} = 90 \text{ N/mm}^2$; $\tau = 60 \text{ MPa} = 60 \text{ N/mm}^2$; $\sigma_c = 150 \text{ MPa} = 150 \text{ N/mm}^2$



Riveted, screwed and welded joints are employed in bridges.

1. Diameter of rivet

We know that the diameter of rivet hole,

$$d = 6 \sqrt{t} = 6 \sqrt{20} = 26.8 \text{ mm}$$

From Table 9.7, we see that according to IS : 1929–1982 (Reaffirmed 1996), the standard diameter of rivet hole (d) is 29 mm and the corresponding diameter of rivet is 27 mm. **Ans.**

2. Number of rivets

Let n = Number of rivets.

We know that the maximum pull acting on the joint,

$$P_t = (b - d) t \times \sigma_t = (350 - 29) 20 \times 90 = 577\,800 \text{ N}$$

Since the joint is double strap butt joint, therefore the rivets are in double shear. Assume that the resistance of the rivet in double shear is 1.75 times than in single shear.

∴ Shearing resistance of one rivet,

$$P_s = 1.75 \times \frac{\pi}{4} \times d^2 \times \tau = 1.75 \times \frac{\pi}{4} (29)^2 \times 60 = 69\,360 \text{ N}$$

and crushing resistance of one rivet,

$$P_c = d \times t \times \sigma_c = 29 \times 20 \times 150 = 87\,000 \text{ N}$$

Since the shearing resistance is less than crushing resistance, therefore number of rivets required for the joint,

$$n = \frac{P_t}{P_s} = \frac{577\,800}{69\,360} = 8.33 \text{ say } 9 \quad \text{Ans.}$$

3. The arrangement of rivets is shown in Fig. 9.21.

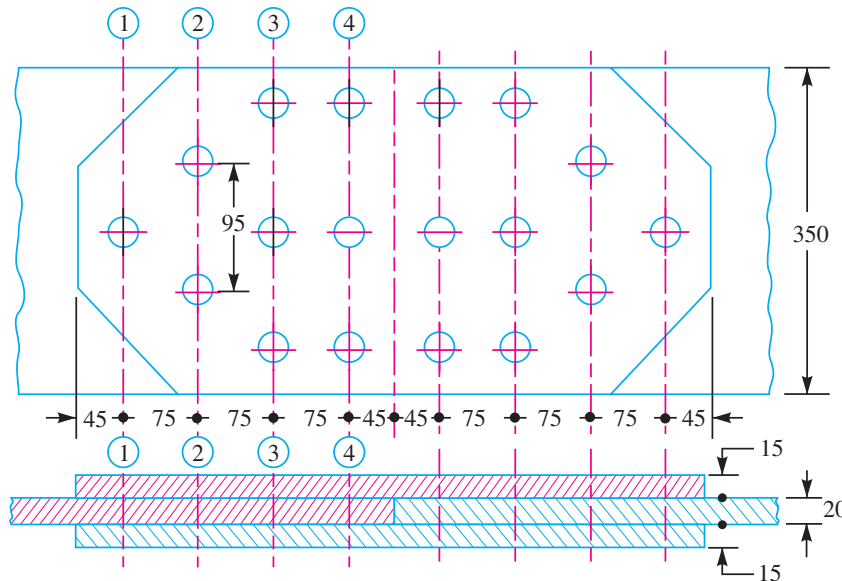

Fig. 9.21. All dimensions in mm.

4. Thickness of butt straps

We know that the thickness of butt straps,

$$t_1 = 0.75 t = 0.75 \times 20 = 15 \text{ mm} \quad \text{Ans.}$$

5. Efficiency of the joint

First of all, let us find the resistances along the sections 1-1, 2-2, 3-3 and 4-4.

At section 1-1, there is only one rivet hole.

∴ Resistance of the joint in tearing along 1-1,

$$P_{t1} = (b - d) t \times \sigma_t = (350 - 29) 20 \times 90 = 577\,800 \text{ N}$$

At section 2-2, there are two rivet holes. In this case the tearing of the plate will only take place if the rivet at section 1-1 (in front of section 2-2) gives way.

∴ Resistance of the joint in tearing along 2-2,

$$P_{t2} = (b - 2d) t \times \sigma_t + \text{Shearing strength of one rivet in front} \\ = (350 - 2 \times 29) 20 \times 90 + 69\,360 = 594\,960 \text{ N}$$

At section 3-3, there are three rivet holes. The tearing of the plate will only take place if one rivet at section 1-1 and two rivets at section 2-2 gives way.

∴ Resistance of the joint in tearing along 3-3,

$$P_{t3} = (b - 3d) t \times \sigma_t + \text{Shearing strength of 3 rivets in front.} \\ = (350 - 3 \times 29) 20 \times 90 + 3 \times 69\,360 = 681\,480 \text{ N}$$

Similarly, resistance of the joint in tearing along 4-4,

$$P_{t4} = (b - 3d) t \times \sigma_t + \text{Shearing strength of 6 rivets in front} \\ = (350 - 3 \times 29) 20 \times 90 + 6 \times 69\,360 = 889\,560 \text{ N}$$

Shearing resistance of all the 9 rivets,

$$P_s = 9 \times 69\,360 = 624\,240 \text{ N}$$

and crushing resistance of all the 9 rivets,

$$P_c = 9 \times 87\,000 = 783\,000 \text{ N}$$

The strength of the joint is the least of P_{t1} , P_{t2} , P_{t3} , P_{t4} , P_s and P_c .

∴ Strength of the joint

$$= 577\,800 \text{ N along section 1-1}$$

We know that the strength of the un-riveted plate,

$$P = b \times t \times \sigma_t = 350 \times 20 \times 90 = 630\,000 \text{ N}$$

∴ Efficiency of the joint,

$$\eta = \frac{\text{Strength of the joint}}{\text{Strength of the un-riveted plate}} = \frac{577\,800}{630\,000} \\ = 0.917 \text{ or } 91.7\% \quad \text{Ans.}$$

6. Pitch of rivets, $p = 3d + 5 \text{ mm} = 3 \times 29 + 5 = 92 \text{ say } 95 \text{ mm} \quad \text{Ans.}$

7. Marginal pitch, $m = 1.5d = 1.5 \times 29 = 43.5 \text{ say } 45 \text{ mm} \quad \text{Ans.}$

8. Distance between the rows of rivets

$$= 2.5d = 2.5 \times 29 = 72.5 \text{ say } 75 \text{ mm} \quad \text{Ans.}$$

Note : If chain riveting with three rows of three rivets in each is used instead of diamond riveting, then Least strength of the joint

$$= (b - 3d) t \times \sigma_t = (350 - 3 \times 29) 20 \times 90 = 473\,400 \text{ N}$$

$$\therefore \text{Efficiency of the joint} = \frac{473\,400}{630\,000} = 0.752 \text{ or } 75.2\%$$

Thus we see that with the use of diamond riveting, efficiency of the joint is increased.

Example 9.13. Design a lap joint for a mild steel flat tie-bar $200 \text{ mm} \times 10 \text{ mm}$ thick, using 24 mm diameter rivets. Assume allowable stresses in tension and compression of the plate material as 112 MPa and 200 MPa respectively and shear stress of the rivets as 84 MPa . Show the disposition of the rivets for maximum joint efficiency and determine the joint efficiency. Take diameter of rivet hole as 25.5 mm for a 24 mm diameter rivet.

Solution. Given : $b = 200 \text{ mm}$; $t = 10 \text{ mm}$; $\sigma_t = 112 \text{ MPa} = 112 \text{ N/mm}^2$; $\sigma_c = 200 \text{ MPa} = 200 \text{ N/mm}^2$; $\tau = 84 \text{ MPa} = 84 \text{ N/mm}^2$; $d = 25.5 \text{ mm}$; $d_1 = 24 \text{ mm}$

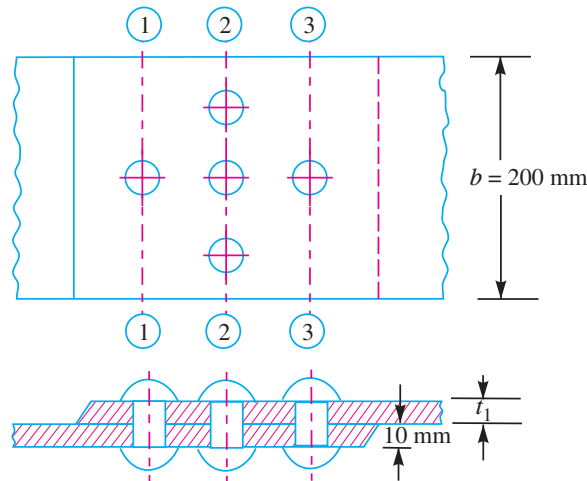

Fig. 9.22

1. Number of rivets

Let $n =$ Number of rivets.

We know that the maximum pull acting on the joint,

$$P_t = (b - d) t \times \sigma_t = (200 - 25.5) 10 \times 112 = 195\,440 \text{ N}$$

Since the joint is a lap joint, therefore shearing resistance of one rivet,

$$P_s = \frac{\pi}{4} \times d^2 \times \tau = \frac{\pi}{4} (25.5)^2 84 = 42\,905 \text{ N}$$

and crushing resistance of one rivet,

$$P_c = d \times t \times \sigma_c = 25.5 \times 10 \times 200 = 51\,000 \text{ N}$$

Since the shearing resistance is less than the crushing resistance, therefore number of rivets required for the joint,

$$n = \frac{P_t}{P_s} = \frac{195\,440}{42\,905} = 4.56 \text{ say } 5 \quad \text{Ans.}$$

2. The arrangement of the rivets is shown in Fig. 9.22.

3. Thickness of the cover plate

We know that the thickness of a cover plate for lap joint,

$$t_1 = 1.25 t = 1.25 \times 10 = 12.5 \text{ mm} \quad \text{Ans.}$$

4. Efficiency of the joint

First of all, let us find the resistances along the sections 1-1, 2-2 and 3-3. At section 1-1, there is only one rivet hole.

\therefore Resistance of the joint in tearing along section 1-1,

$$P_{t1} = (b - d) t \times \sigma_t = (200 - 25.5) 10 \times 112 = 195\,440 \text{ N}$$

At section 2-2, there are three rivet holes. In this case, the tearing of the plate will only take place if the rivet at section 1-1 (in front of section 2-2) gives way (*i.e.* shears).

322 ■ A Textbook of Machine Design

∴ Resistance of the joint in tearing along section 2-2,

$$P_{t2} = (b - 3d) t \times \sigma_t + \text{Shearing resistance of one rivet} \\ = (200 - 3 \times 25.5) 10 \times 112 + 42\,905 = 181\,285 \text{ N}$$

At section 3-3, there is only one rivet hole. The resistance of the joint in tearing along section 3-3 will be same as at section 1-1.

$$P_{t3} = P_{t1} = 195\,440 \text{ N}$$

Shearing resistance of all the five rivets,

$$P_s = 5 \times 42\,905 = 214\,525 \text{ N}$$

and crushing resistance of all the five rivets,

$$P_c = 5 \times 51\,000 = 255\,000 \text{ N}$$

Since the strength of the joint is the least value of P_{t1} , P_{t2} , P_{t3} , P_s and P_c , therefore strength of the joint

$$= 181\,285 \text{ N at section 2-2}$$

We know that strength of the un-riveted plate

$$= b \times t \times \sigma_t = 200 \times 10 \times 112 = 224\,000 \text{ N}$$

∴ Efficiency of the joint,

$$\eta = \frac{\text{Strength of the joint}}{\text{Strength of the un-riveted plate}} = \frac{181\,285}{224\,000} \\ = 0.809 \text{ or } 80.9\% \quad \text{Ans.}$$

9.21 Eccentric Loaded Riveted Joint

When the line of action of the load does not pass through the centroid of the rivet system and thus all rivets are not equally loaded, then the joint is said to be an *eccentric loaded riveted joint*, as shown in Fig. 9.23 (a). The eccentric loading results in secondary shear caused by the tendency of force to twist the joint about the centre of gravity in addition to direct shear or primary shear.

Let

P = Eccentric load on the joint, and

e = Eccentricity of the load *i.e.* the distance between the line of action of the load and the centroid of the rivet system *i.e.* G .

The following procedure is adopted for the design of an eccentrically loaded riveted joint.

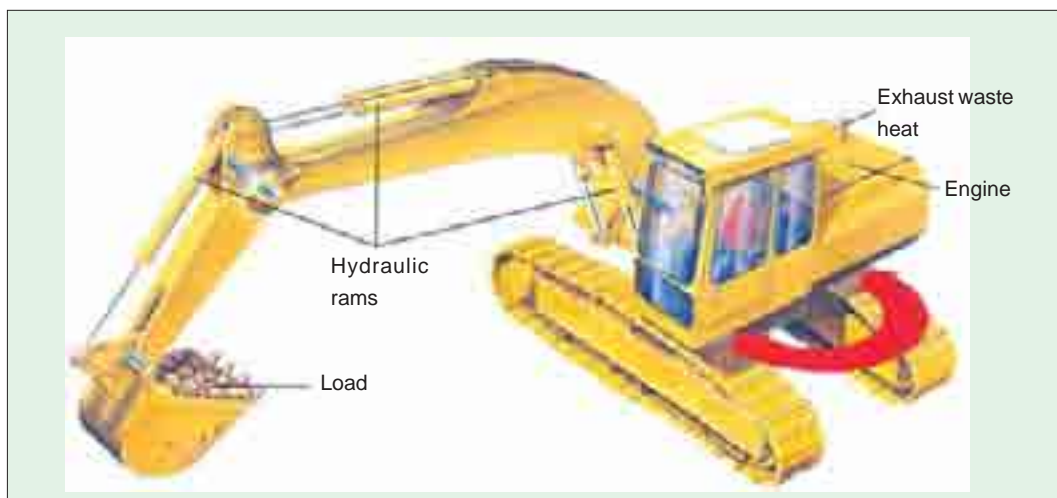

Note : This picture is given as additional information and is not a direct example of the current chapter.

1. First of all, find the centre of gravity G of the rivet system.

Let A = Cross-sectional area of each rivet,

x_1, x_2, x_3 etc. = Distances of rivets from OY , and

y_1, y_2, y_3 etc. = Distances of rivets from OX .

We know that

$$\bar{x} = \frac{A_1 x_1 + A_2 x_2 + A_3 x_3 + \dots}{A_1 + A_2 + A_3 + \dots} = \frac{A x_1 + A x_2 + A x_3 + \dots}{n \cdot A}$$

$$= \frac{x_1 + x_2 + x_3 + \dots}{n} \quad \dots(\text{where } n = \text{Number of rivets})$$

Similarly,

$$\bar{y} = \frac{y_1 + y_2 + y_3 + \dots}{n}$$

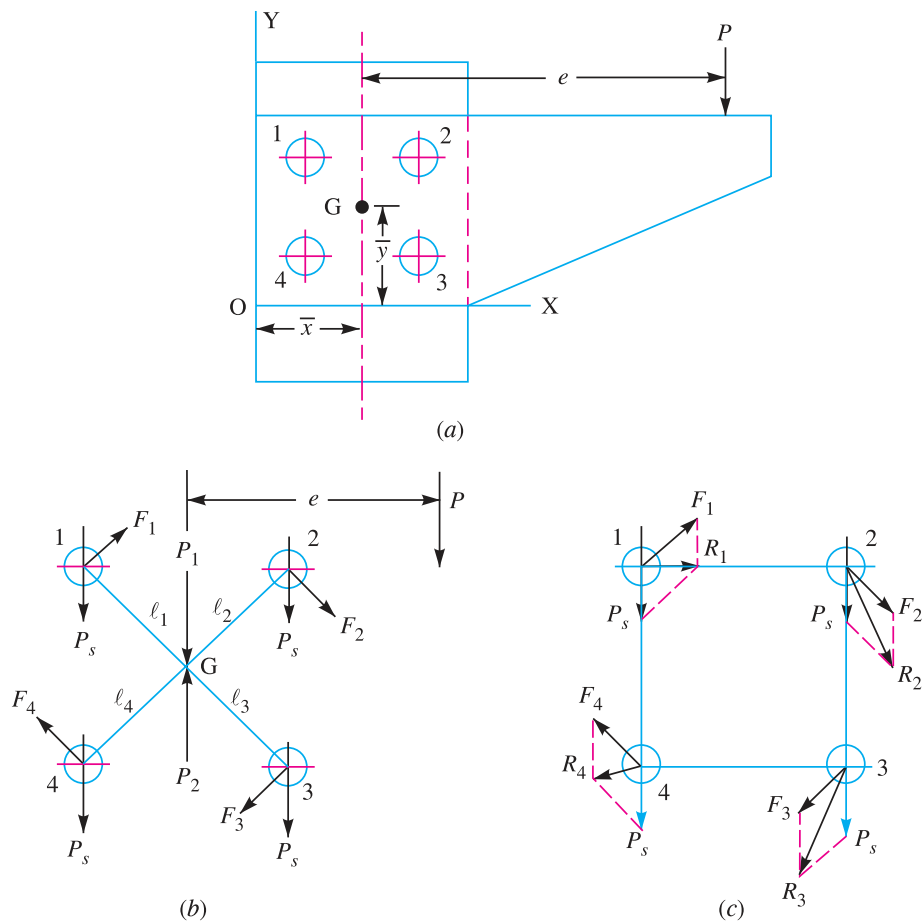

Fig. 9.23. Eccentric loaded riveted joint.

2. Introduce two forces P_1 and P_2 at the centre of gravity ‘ G ’ of the rivet system. These forces are equal and opposite to P as shown in Fig. 9.23 (b).

3. Assuming that all the rivets are of the same size, the effect of $P_1 = P$ is to produce direct shear load on each rivet of equal magnitude. Therefore, direct shear load on each rivet,

$$P_s = \frac{P}{n}, \text{ acting parallel to the load } P.$$

324 ■ A Textbook of Machine Design

4. The effect of $P_2 = P$ is to produce a turning moment of magnitude $P \times e$ which tends to rotate the joint about the centre of gravity 'G' of the rivet system in a clockwise direction. Due to the turning moment, secondary shear load on each rivet is produced. In order to find the secondary shear load, the following two assumptions are made :

- (a) The secondary shear load is proportional to the radial distance of the rivet under consideration from the centre of gravity of the rivet system.
- (b) The direction of secondary shear load is perpendicular to the line joining the centre of the rivet to the centre of gravity of the rivet system..

Let $F_1, F_2, F_3 \dots$ = Secondary shear loads on the rivets 1, 2, 3...etc.
 $l_1, l_2, l_3 \dots$ = Radial distance of the rivets 1, 2, 3 ...etc. from the centre of gravity 'G' of the rivet system.

∴ From assumption (a),

$$F_1 \propto l_1 ; F_2 \propto l_2 \text{ and so on}$$

or
$$\frac{F_1}{l_1} = \frac{F_2}{l_2} = \frac{F_3}{l_3} = \dots$$

∴
$$F_2 = F_1 \times \frac{l_2}{l_1}, \text{ and } F_3 = F_1 \times \frac{l_3}{l_1}$$

We know that the sum of the external turning moment due to the eccentric load and of internal resisting moment of the rivets must be equal to zero.

$$\begin{aligned} \therefore P.e &= F_1.l_1 + F_2.l_2 + F_3.l_3 + \dots \\ &= F_1.l_1 + F_1 \times \frac{l_2}{l_1} \times l_2 + F_1 \times \frac{l_3}{l_1} \times l_3 + \dots \\ &= \frac{F_1}{l_1} [(l_1)^2 + (l_2)^2 + (l_3)^2 + \dots] \end{aligned}$$

From the above expression, the value of F_1 may be calculated and hence F_2 and F_3 etc. are known. The direction of these forces are at right angles to the lines joining the centre of rivet to the centre of gravity of the rivet system, as shown in Fig. 9.23 (b), and should produce the moment in the same direction (*i.e.* clockwise or anticlockwise) about the centre of gravity, as the turning moment ($P \times e$).

5. The primary (or direct) and secondary shear load may be added vectorially to determine the resultant shear load (R) on each rivet as shown in Fig. 9.23 (c). It may also be obtained by using the relation

$$R = \sqrt{(P_s)^2 + F^2 + 2P_s \times F \times \cos \theta}$$

where

θ = Angle between the primary or direct shear load (P_s) and secondary shear load (F).

When the secondary shear load on each rivet is equal, then the heavily loaded rivet will be one in which the included angle between the direct shear load and secondary shear load is minimum. The maximum loaded rivet becomes the critical one for determining the strength of the riveted joint. Knowing the permissible shear stress (τ), the diameter of the rivet hole may be obtained by using the relation,

$$\text{Maximum resultant shear load } (R) = \frac{\pi}{4} \times d^2 \times \tau$$

From Table 9.7, the standard diameter of the rivet hole (d) and the rivet diameter may be specified, according to IS : 1929 – 1982 (Reaffirmed 1996).

Notes : 1. In the solution of a problem, the primary and shear loads may be laid off approximately to scale and generally the rivet having the maximum resultant shear load will be apparent by inspection. The values of the load for that rivet may then be calculated.

2. When the thickness of the plate is given, then the diameter of the rivet hole may be checked against crushing.

3. When the eccentric load P is inclined at some angle, then the same procedure as discussed above may be followed to find the size of rivet (See Example 9.18).

Example 9.14. An eccentrically loaded lap riveted joint is to be designed for a steel bracket as shown in Fig. 9.24.

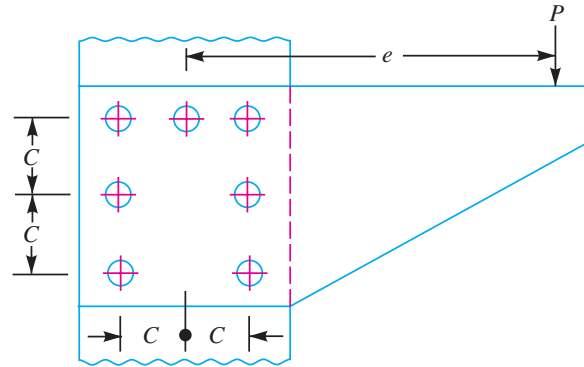

Fig. 9.24

The bracket plate is 25 mm thick. All rivets are to be of the same size. Load on the bracket, $P = 50 \text{ kN}$; rivet spacing, $C = 100 \text{ mm}$; load arm, $e = 400 \text{ mm}$.

Permissible shear stress is 65 MPa and crushing stress is 120 MPa. Determine the size of the rivets to be used for the joint.

Solution. Given : $t = 25 \text{ mm}$; $P = 50 \text{ kN} = 50 \times 10^3 \text{ N}$; $e = 400 \text{ mm}$; $n = 7$; $\tau = 65 \text{ MPa} = 65 \text{ N/mm}^2$; $\sigma_c = 120 \text{ MPa} = 120 \text{ N/mm}^2$

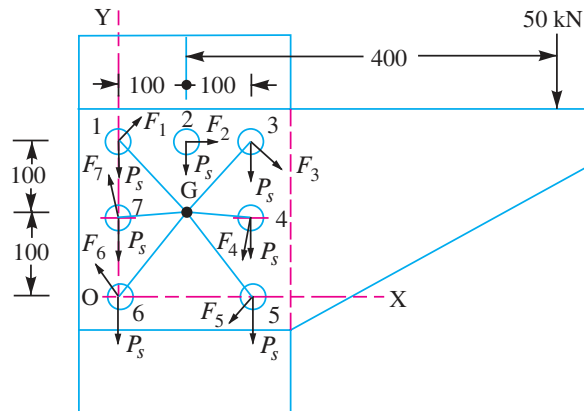

Fig. 9.25

First of all, let us find the centre of gravity (G) of the rivet system.

Let

$$\bar{x} = \text{Distance of centre of gravity from } OY,$$

$$\bar{y} = \text{Distance of centre of gravity from } OX,$$

326 ■ A Textbook of Machine Design

x_1, x_2, x_3, \dots = Distances of centre of gravity of each rivet from OY , and

y_1, y_2, y_3, \dots = Distances of centre of gravity of each rivet from OX .

We know that
$$\bar{x} = \frac{x_1 + x_2 + x_3 + x_4 + x_5 + x_6 + x_7}{n}$$

$$= \frac{100 + 200 + 200 + 200}{7} = 100 \text{ mm} \quad \dots(\because x_1 = x_6 = x_7 = 0)$$

and
$$\bar{y} = \frac{y_1 + y_2 + y_3 + y_4 + y_5 + y_6 + y_7}{n}$$

$$= \frac{200 + 200 + 200 + 100 + 100}{7} = 114.3 \text{ mm} \quad \dots(\because y_5 = y_6 = 0)$$

\therefore The centre of gravity (G) of the rivet system lies at a distance of 100 mm from OY and 114.3 mm from OX , as shown in Fig. 9.25.

We know that direct shear load on each rivet,

$$P_s = \frac{P}{n} = \frac{50 \times 10^3}{7} = 7143 \text{ N}$$

The direct shear load acts parallel to the direction of load P i.e. vertically downward as shown in Fig. 9.25.

Turning moment produced by the load P due to eccentricity (e)

$$= P \times e = 50 \times 10^3 \times 400 = 20 \times 10^6 \text{ N-mm}$$

This turning moment is resisted by seven rivets as shown in Fig. 9.25.

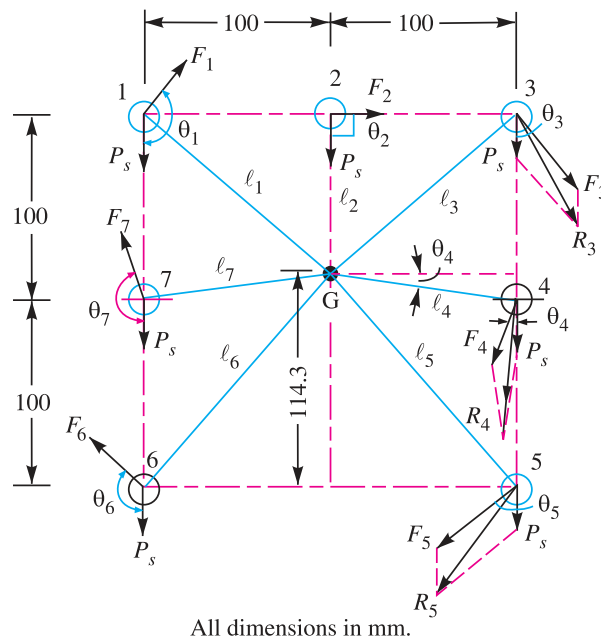

Fig. 9.26

Let $F_1, F_2, F_3, F_4, F_5, F_6$ and F_7 be the secondary shear load on the rivets 1, 2, 3, 4, 5, 6 and 7 placed at distances $l_1, l_2, l_3, l_4, l_5, l_6$ and l_7 respectively from the centre of gravity of the rivet system as shown in Fig. 9.26.

From the geometry of the figure, we find that

$$l_1 = l_3 = \sqrt{(100)^2 + (200 - 114.3)^2} = 131.7 \text{ mm}$$

$$l_2 = 200 - 114.3 = 85.7 \text{ mm}$$

$$l_4 = l_7 = \sqrt{(100)^2 + (114.3 - 100)^2} = 101 \text{ mm}$$

and

$$l_5 = l_6 = \sqrt{(100)^2 + (114.3)^2} = 152 \text{ mm}$$

Now equating the turning moment due to eccentricity of the load to the resisting moment of the rivets, we have

$$\begin{aligned} P \times e &= \frac{F_1}{l_1} \left[(l_1)^2 + (l_2)^2 + (l_3)^2 + (l_4)^2 + (l_5)^2 + (l_6)^2 + (l_7)^2 \right] \\ &= \frac{F_1}{l_1} \left[2(l_1)^2 + (l_2)^2 + 2(l_4)^2 + 2(l_5)^2 \right] \\ &\quad \dots(\because l_1 = l_3; l_4 = l_7 \text{ and } l_5 = l_6) \end{aligned}$$

$$\begin{aligned} 50 \times 10^3 \times 400 &= \frac{F_1}{131.7} \left[2(131.7)^2 + (85.7)^2 + 2(101)^2 + 2(152)^2 \right] \\ 20 \times 10^6 \times 131.7 &= F_1(34\,690 + 7345 + 20\,402 + 46\,208) = 108\,645 F_1 \end{aligned}$$

$$\therefore F_1 = 20 \times 10^6 \times 131.7 / 108\,645 = 24\,244 \text{ N}$$

Since the secondary shear loads are proportional to their radial distances from the centre of gravity, therefore

$$F_2 = F_1 \times \frac{l_2}{l_1} = 24\,244 \times \frac{85.7}{131.7} = 15\,776 \text{ N}$$

$$F_3 = F_1 \times \frac{l_3}{l_1} = F_1 = 24\,244 \text{ N} \quad \dots(\because l_1 = l_3)$$

$$F_4 = F_1 \times \frac{l_4}{l_1} = 24\,244 \times \frac{101}{131.7} = 18\,593 \text{ N}$$

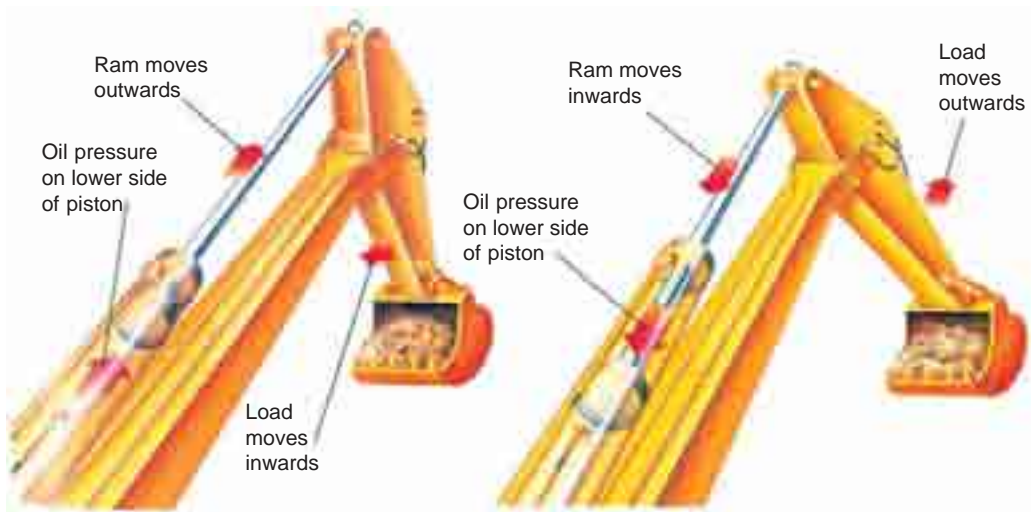

Arms of a digger.

Note : This picture is given as additional information and is not a direct example of the current chapter.

$$F_5 = F_1 \times \frac{l_5}{l_1} = 24\,244 \times \frac{152}{131.7} = 27\,981 \text{ N}$$

$$F_6 = F_1 \times \frac{l_6}{l_1} = F_5 = 27\,981 \text{ N} \quad \dots(\because l_6 = l_5)$$

$$F_7 = F_1 \times \frac{l_7}{l_1} = F_4 = 18\,593 \text{ N} \quad \dots(\because l_7 = l_4)$$

By drawing the direct and secondary shear loads on each rivet, we see that the rivets 3, 4 and 5 are heavily loaded. Let us now find the angles between the direct and secondary shear load for these three rivets. From the geometry of Fig. 9.26, we find that

$$\cos \theta_3 = \frac{100}{l_3} = \frac{100}{131.7} = 0.76$$

$$\cos \theta_4 = \frac{100}{l_4} = \frac{100}{101} = 0.99$$

and
$$\cos \theta_5 = \frac{100}{l_5} = \frac{100}{152} = 0.658$$

Now resultant shear load on rivet 3,

$$\begin{aligned} R_3 &= \sqrt{(P_s)^2 + (F_3)^2 + 2P_s \times F_3 \times \cos \theta_3} \\ &= \sqrt{(7143)^2 + (24\,244)^2 + 2 \times 7143 \times 24\,244 \times 0.76} = 30\,033 \text{ N} \end{aligned}$$

Resultant shear load on rivet 4,

$$\begin{aligned} R_4 &= \sqrt{(P_s)^2 + (F_4)^2 + 2P_s \times F_4 \times \cos \theta_4} \\ &= \sqrt{(7143)^2 + (18\,593)^2 + 2 \times 7143 \times 18\,593 \times 0.99} = 25\,684 \text{ N} \end{aligned}$$

and resultant shear load on rivet 5,

$$\begin{aligned} R_5 &= \sqrt{(P_s)^2 + (F_5)^2 + 2P_s \times F_5 \times \cos \theta_5} \\ &= \sqrt{(7143)^2 + (27\,981)^2 + 2 \times 7143 \times 27\,981 \times 0.658} = 33\,121 \text{ N} \end{aligned}$$

The resultant shear load may be determined graphically, as shown in Fig. 9.26.

From above we see that the maximum resultant shear load is on rivet 5. If d is the diameter of rivet hole, then maximum resultant shear load (R_5),

$$33\,121 = \frac{\pi}{4} \times d^2 \times \tau = \frac{\pi}{4} \times d^2 \times 65 = 51 d^2$$

$$\therefore d^2 = 33\,121 / 51 = 649.4 \quad \text{or} \quad d = 25.5 \text{ mm}$$

From Table 9.7, we see that according to IS : 1929–1982 (Reaffirmed 1996), the standard diameter of the rivet hole (d) is 25.5 mm and the corresponding diameter of rivet is 24 mm.

Let us now check the joint for crushing stress. We know that

$$\begin{aligned} \text{Crushing stress} &= \frac{\text{Max. load}}{\text{Crushing area}} = \frac{R_5}{d \times t} = \frac{33\,121}{25.5 \times 25} \\ &= 51.95 \text{ N/mm}^2 = 51.95 \text{ MPa} \end{aligned}$$

Since this stress is well below the given crushing stress of 120 MPa, therefore the design is satisfactory.

Example 9.15. The bracket as shown in Fig. 9.27, is to carry a load of 45 kN. Determine the size of the rivet if the shear stress is not to exceed 40 MPa. Assume all rivets of the same size.

Solution. Given : $P = 45 \text{ kN} = 45 \times 10^3 \text{ N}$; $\tau = 40 \text{ MPa} = 40 \text{ N/mm}^2$; $e = 500 \text{ mm}$; $n = 9$

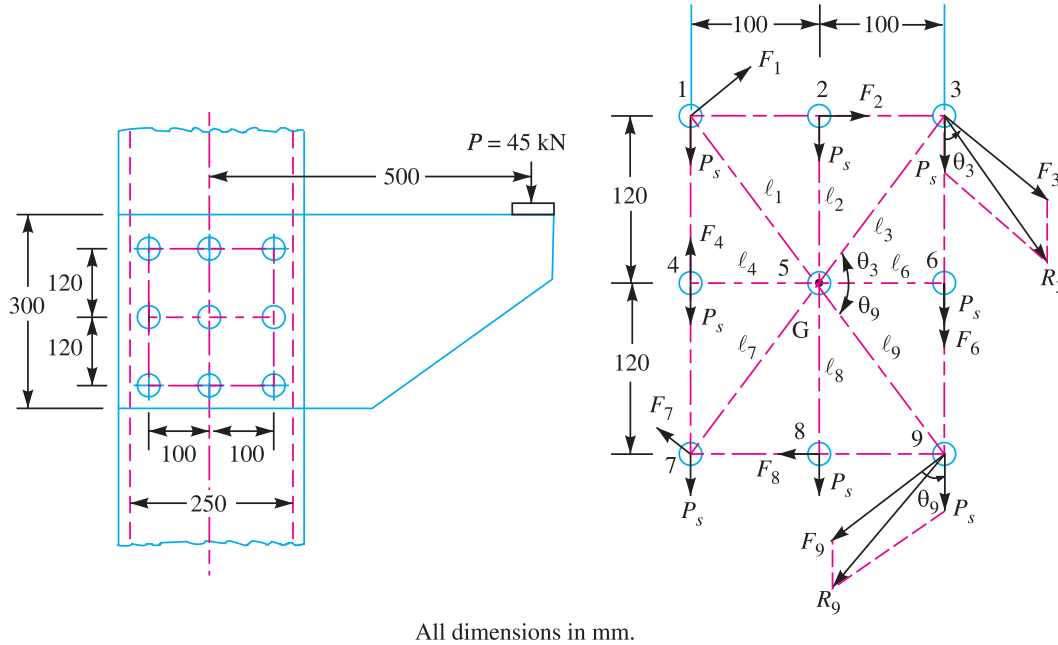

Fig. 9.27

Fig. 9.28

First of all, let us find the centre of gravity of the rivet system.

Since all the rivets are of same size and placed symmetrically, therefore the centre of gravity of the rivet system lies at G (rivet 5) as shown in Fig. 9.28.

We know that direct shear load on each rivet,

$$P_s = P / n = 45 \times 10^3 / 9 = 5000 \text{ N}$$

The direct shear load acts parallel to the direction of load P , i.e. vertically downward as shown in the figure.

Turning moment produced by the load P due to eccentricity e

$$= P.e = 45 \times 10^3 \times 500 = 22.5 \times 10^6 \text{ N-mm}$$

This turning moment tends to rotate the joint about the centre of gravity (G) of the rivet system in a clockwise direction. Due to this turning moment, secondary shear load on each rivet is produced. It may be noted that rivet 5 does not resist any moment.

Let $F_1, F_2, F_3, F_4, F_6, F_7, F_8$ and F_9 be the secondary shear load on rivets 1, 2, 3, 4, 6, 7, 8 and 9 at distances $l_1, l_2, l_3, l_4, l_6, l_7, l_8$ and l_9 from the centre of gravity (G) of the rivet system as shown in Fig. 9.28. From the symmetry of the figure, we find that

$$l_1 = l_3 = l_7 = l_9 = \sqrt{(100)^2 + (120)^2} = 156.2 \text{ mm}$$

Now equating the turning moment due to eccentricity of the load to the resisting moments of the rivets, we have

$$P \times e = \frac{F_1}{l_1} \left[(l_1)^2 + (l_2)^2 + (l_3)^2 + (l_4)^2 + (l_6)^2 + (l_7)^2 + (l_8)^2 + (l_9)^2 \right]$$

$$= \frac{F_1}{l_1} [4(l_1)^2 + 2(l_2)^2 + 2(l_4)^2] \dots (\because l_1 = l_3 = l_7 = l_9; l_2 = l_8 \text{ and } l_4 = l_6)$$

$$\therefore 45 \times 10^3 \times 500 = \frac{F_1}{156.2} [4(156.2)^2 + 2(120)^2 + 2(100)^2] = 973.2 F_1$$

or $F_1 = 45 \times 10^3 \times 500 / 973.2 = 23\,120 \text{ N}$

Since the secondary shear loads are proportional to their radial distances from the centre of gravity (G), therefore

$$F_2 = F_1 \times \frac{l_2}{l_1} = F_8 = 23\,120 \times \frac{120}{156.2} = 17\,762 \text{ N} \quad \dots (\because l_2 = l_8)$$

$$F_3 = F_1 \times \frac{l_3}{l_1} = F_1 = F_7 = F_9 = 23\,120 \text{ N} \quad \dots (\because l_3 = l_7 = l_9 = l_1)$$

and $F_4 = F_1 \times \frac{l_4}{l_1} = F_6 = 23\,120 \times \frac{100}{156.2} = 14\,800 \text{ N} \quad \dots (\because l_4 = l_6)$

The secondary shear loads acts perpendicular to the line joining the centre of rivet and the centre of gravity of the rivet system, as shown in Fig. 9.28 and their direction is clockwise.

By drawing the direct and secondary shear loads on each rivet, we see that the rivets 3, 6 and 9 are heavily loaded. Let us now find the angle between the direct and secondary shear loads for these rivets. From the geometry of the figure, we find that

$$\cos \theta_3 = \cos \theta_9 = \frac{100}{l_3} = \frac{100}{156.2} = 0.64$$

\therefore Resultant shear load on rivets 3 and 9,

$$R_3 = R_9 = \sqrt{(P_s)^2 + (F_3)^2 + 2 P_s \times F_3 \times \cos \theta_3}$$

$$= \sqrt{(5000)^2 + (23\,120)^2 + 2 \times 5000 \times 23\,120 \times 0.64} = 26\,600 \text{ N}$$

$\dots (\because F_3 = F_9 \text{ and } \cos \theta_3 = \cos \theta_9)$

and resultant shear load on rivet 6,

$$R_6 = P_s + F_6 = 5000 + 14\,800 = 19\,800 \text{ N}$$

The resultant shear load (R_3 or R_9) may be determined graphically as shown in Fig. 9.28.

From above we see that the maximum resultant shear load is on rivets 3 and 9.

If d is the diameter of the rivet hole, then maximum resultant shear load (R_3),

$$26\,600 = \frac{\pi}{4} \times d^2 \times \tau = \frac{\pi}{4} \times d^2 \times 40 = 31.42 d^2$$

$$\therefore d^2 = 26\,600 / 31.42 = 846 \text{ or } d = 29 \text{ mm}$$

From Table 9.7, we see that according to IS : 1929 – 1982 (Reaffirmed 1996), the standard diameter of the rivet hole (d) is 29 mm and the corresponding diameter of the rivet is 27 mm. **Ans.**

Example 9.16. Find the value of P for the joint shown in Fig. 9.29 based on a working shear stress of 100 MPa for the rivets. The four rivets are equal, each of 20 mm diameter.

Solution. Given : $\tau = 100 \text{ MPa} = 100 \text{ N/mm}^2$; $n = 4$; $d = 20 \text{ mm}$

We know that the direct shear load on each rivet,

$$P_s = \frac{P}{n} = \frac{P}{4} = 0.25 P$$

The direct shear load on each rivet acts in the direction of the load P , as shown in Fig. 9.30. The centre of gravity of the rivet group will lie at E (because of symmetry). From Fig. 9.30, we find that

the perpendicular distance from the centre of gravity E to the line of action of the load (or eccentricity),

$$EC = e = 100 \text{ mm}$$

∴ Turning moment produced by the load at the centre of gravity (E) of the rivet system due to eccentricity

$$= P.e = P \times 100 \text{ N-mm (anticlockwise)}$$

This turning moment is resisted by four rivets as shown in Fig. 9.30. Let F_A, F_B, F_C and F_D be the secondary shear load on the rivets, A, B, C , and D placed at distances l_A, l_B, l_C and l_D respectively from the centre of gravity of the rivet system.

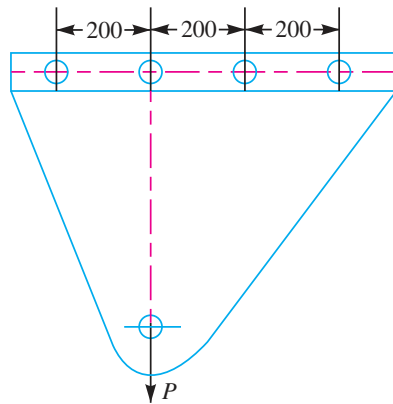

Fig. 9.29

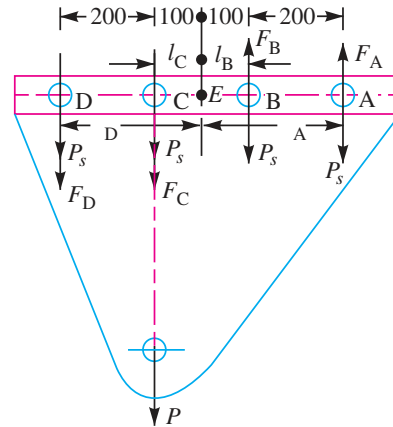

Fig. 9.30

All dimensions in mm.

From Fig. 9.30, we find that

$$l_A = l_D = 200 + 100 = 300 \text{ mm} ; \text{ and } l_B = l_C = 100 \text{ mm}$$

We know that

$$P \times e = \frac{F_A}{l_A} [(l_A)^2 + (l_B)^2 + (l_C)^2 + (l_D)^2] = \frac{F_A}{l_A} [2(l_A)^2 + 2(l_B)^2]$$

... (∵ $l_A = l_D$ and $l_B = l_C$)

$$P \times 100 = \frac{F_A}{300} [2(300)^2 + 2(100)^2] = \frac{2000}{3} \times F_A$$

$$\therefore F_A = P \times 100 \times 3 / 2000 = 3P/20 = 0.15 P \text{ N}$$

Since the secondary shear loads are proportional to their radial distances from the centre of gravity, therefore

$$F_B = F_A \times \frac{l_B}{l_A} = \frac{3P}{20} \times \frac{100}{300} = 0.05 P \text{ N}$$

$$F_C = F_A \times \frac{l_C}{l_A} = \frac{3P}{20} \times \frac{100}{300} = 0.05 P \text{ N}$$

and

$$F_D = F_A \times \frac{l_D}{l_A} = \frac{3P}{20} \times \frac{300}{300} = 0.15 P \text{ N}$$

The secondary shear loads on each rivet act at right angles to the lines joining the centre of the rivet to the centre of gravity of the rivet system as shown in Fig. 9.30.

Now let us find out the resultant shear load on each rivet. From Fig. 9.30, we find that

Resultant load on rivet A,

$$R_A = P_s - F_A = 0.25 P - 0.15 P = 0.10 P$$

332 ■ A Textbook of Machine Design

Resultant load on rivet *B*,

$$R_B = P_s - F_B = 0.25 P - 0.05 P = 0.20 P$$

Resultant load on rivet *C*,

$$R_C = P_s + F_C = 0.25 P + 0.05 P = 0.30 P$$

and resultant load on rivet *D*,

$$R_D = P_s + F_D = 0.25 P + 0.15 P = 0.40 P$$

From above we see that the maximum shear load is on rivet *D*. We know that the maximum shear load (R_D),

$$0.40 P = \frac{\pi}{4} \times d^2 \times \tau = \frac{\pi}{4} (20)^2 100 = 31\,420$$

$$\therefore P = 31\,420 / 0.40 = 78\,550 \text{ N} = 78.55 \text{ kN} \quad \text{Ans.}$$

Example 9.17. A bracket is riveted to a column by 6 rivets of equal size as shown in Fig. 9.31.

It carries a load of 60 kN at a distance of 200 mm from the centre of the column. If the maximum shear stress in the rivet is limited to 150 MPa, determine the diameter of the rivet.

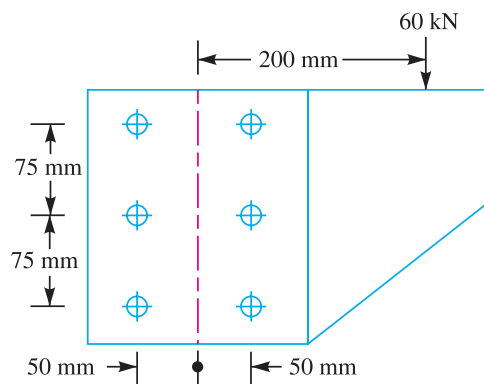

Fig. 9.31

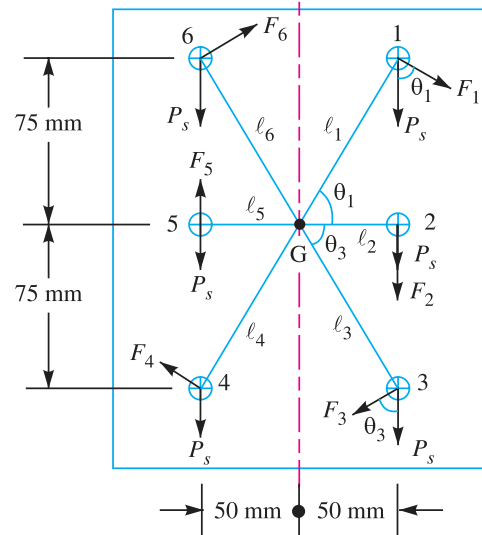

Fig. 9.32

Solution. Given : $n = 6$; $P = 60 \text{ kN} = 60 \times 10^3 \text{ N}$; $e = 200 \text{ mm}$; $\tau = 150 \text{ MPa} = 150 \text{ N/mm}^2$

Since the rivets are of equal size and placed symmetrically, therefore the centre of gravity of the rivet system lies at *G* as shown in Fig. 9.32. We know that direct shear load on each rivet,

$$P_s = \frac{P}{n} = \frac{60 \times 10^3}{6} = 10\,000 \text{ N}$$

Let F_1, F_2, F_3, F_4, F_5 and F_6 be the secondary shear load on the rivets 1, 2, 3, 4, 5 and 6 at distances l_1, l_2, l_3, l_4, l_5 and l_6 from the centre of gravity (*G*) of the rivet system. From the symmetry of the figure, we find that

$$l_1 = l_3 = l_4 = l_6 = \sqrt{(75)^2 + (50)^2} = 90.1 \text{ mm}$$

and

$$l_2 = l_5 = 50 \text{ mm}$$

Now equating the turning moment due to eccentricity of the load to the resisting moments of the rivets, we have

$$P \times e = \frac{F_1}{l_1} [(l_1)^2 + (l_2)^2 + (l_3)^2 + (l_4)^2 + (l_5)^2 + (l_6)^2]$$

$$= \frac{F_1}{l_1} [4(l_1)^2 + 2(l_2)^2]$$

$$\therefore 60 \times 10^3 \times 200 = \frac{F_1}{90.1} [4(90.1)^2 + 2(50)^2] = 416 F_1$$

or $F_1 = 60 \times 10^3 \times 200 / 416 = 28\,846 \text{ N}$

Since the secondary shear loads are proportional to the radial distances from the centre of gravity, therefore

$$F_2 = F_1 \times \frac{l_2}{l_1} = 28\,846 \times \frac{50}{90.1} = 16\,008 \text{ N}$$

$$F_3 = F_1 \times \frac{l_3}{l_1} = F_1 = 28\,846 \text{ N} \quad \dots(\because l_3 = l_1)$$

$$F_4 = F_1 \times \frac{l_4}{l_1} = F_1 = 28\,846 \text{ N} \quad \dots(\because l_4 = l_1)$$

$$F_5 = F_1 \times \frac{l_5}{l_1} = F_2 = 16\,008 \text{ N} \quad \dots(\because l_5 = l_2)$$

and $F_6 = F_1 \times \frac{l_6}{l_1} = F_1 = 28\,846 \text{ N} \quad \dots(\because l_6 = l_1)$

By drawing the direct and secondary shear loads on each rivet, we see that the rivets 1, 2 and 3 are heavily loaded. Let us now find the angles between the direct and secondary shear loads for these three rivets. From the geometry of the figure, we find that

$$\cos \theta_1 = \cos \theta_3 = \frac{50}{l_1} = \frac{50}{90.1} = 0.555$$



Excavator in action

∴ Resultant shear load on rivets 1 and 3,

$$R_1 = R_3 = \sqrt{(P_s)^2 + (F_1)^2 + 2 P_s \times F_1 \times \cos \theta_1}$$

...($\because F_1 = F_3$ and $\cos \theta_1 = \cos \theta_3$)

$$= \sqrt{(10\,000)^2 + (28\,846)^2 + 2 \times 10\,000 \times 28\,846 \times 0.555}$$

$$= \sqrt{100 \times 10^6 + 832 \times 10^6 + 320 \times 10^6} = 35\,348 \text{ N}$$

and resultant shear load on rivet 2,

$$R_2 = P_s + F_2 = 10\,000 + 16\,008 = 26\,008 \text{ N}$$

From above we see that the maximum resultant shear load is on rivets 1 and 3. If d is the diameter of rivet hole, then maximum resultant shear load (R_1 or R_3),

$$35\,384 = \frac{\pi}{4} \times d^2 \times \tau = \frac{\pi}{4} \times d^2 \times 150 = 117.8 d^2$$

$$\therefore d^2 = 35\,384 / 117.8 = 300.4 \quad \text{or} \quad d = 17.33 \text{ mm}$$

From Table 9.7, we see that according to IS : 1929 – 1982 (Reaffirmed 1996), the standard diameter of the rivet hole (d) is 19.5 mm and the corresponding diameter of the rivet is 18 mm. **Ans.**

Example 9.18. A bracket in the form of a plate is fitted to a column by means of four rivets A, B, C and D in the same vertical line, as shown in Fig. 9.33. $AB = BC = CD = 60$ mm. E is the mid-point of BC. A load of 100 kN is applied to the bracket at a point F which is at a horizontal distance of 150 mm from E. The load acts at an angle of 30° to the horizontal. Determine the diameter of the rivets which are made of steel having a yield stress in shear of 240 MPa. Take a factor of safety of 1.5.

What would be the thickness of the plate taking an allowable bending stress of 125 MPa for the plate, assuming its total width at section ABCD as 240 mm?

Solution. Given : $n = 4$; $AB = BC = CD = 60$ mm ; $P = 100$ kN = 100×10^3 N ; $EF = 150$ mm ; $\theta = 30^\circ$; $\tau_y = 240$ MPa = 240 N/mm² ; F.S. = 1.5 ; $\sigma_b = 125$ MPa = 125 N/mm² ; $b = 240$ mm

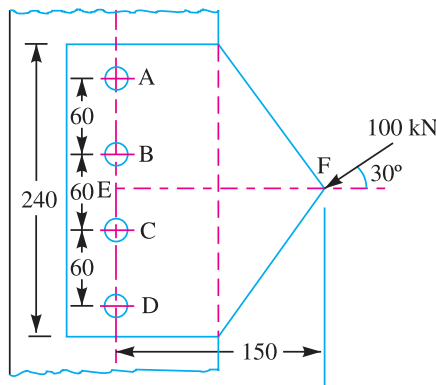

All dimensions in mm.

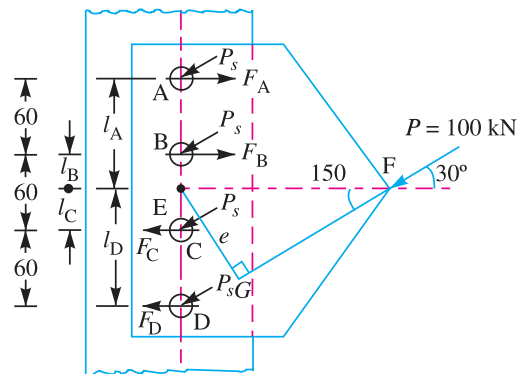

Fig. 9.34

Fig. 9.33

Diameter of rivets

Let

d = Diameter of rivets.

We know that direct shear load on each rivet,

$$P_s = \frac{P}{n} = \frac{100 \times 10^3}{4} = 25\,000 \text{ N}$$

The direct shear load on each rivet acts in the direction of 100 kN load (*i.e.* at 30° to the horizontal) as shown in Fig. 9.34. The centre of gravity of the rivet group lies at E . From Fig. 9.34, we find that the perpendicular distance from the centre of gravity E to the line of action of the load (or eccentricity of the load) is

$$EG = e = EF \sin 30^\circ = 150 \times \frac{1}{2} = 75 \text{ mm}$$

$$\begin{aligned} \therefore \text{Turning moment produced by the load } P \text{ due to eccentricity} \\ = P.e = 100 \times 10^3 \times 75 = 7500 \times 10^3 \text{ N-mm} \end{aligned}$$

This turning moment is resisted by four bolts, as shown in Fig. 9.34. Let F_A , F_B , F_C and F_D be the secondary shear load on the rivets, A , B , C , and D placed at distances l_A , l_B , l_C and l_D respectively from the centre of gravity of the rivet system.

From Fig. 9.34, we find that

$$l_A = l_D = 60 + 30 = 90 \text{ mm and } l_B = l_C = 30 \text{ mm}$$

We know that

$$P \times e = \frac{F_A}{l_A} [(l_A)^2 + (l_B)^2 + (l_C)^2 + (l_D)^2] = \frac{F_A}{l_A} [2(l_A)^2 + 2(l_B)^2]$$

$\dots(\because l_A = l_D \text{ and } l_B = l_C)$

$$7500 \times 10^3 = \frac{F_A}{90} [2(90)^2 + 2(30)^2] = 200 F_A$$

$$\therefore F_A = 7500 \times 10^3 / 200 = 37\,500 \text{ N}$$

Since the secondary shear loads are proportional to their radial distances from the centre of gravity, therefore,

$$F_B = F_A \times \frac{l_B}{l_A} = 37\,500 \times \frac{30}{90} = 12\,500 \text{ N}$$

$$F_C = F_A \times \frac{l_C}{l_A} = 37\,500 \times \frac{30}{90} = 12\,500 \text{ N}$$

and
$$F_D = F_A \times \frac{l_D}{l_A} = 37\,500 \times \frac{90}{90} = 37\,500 \text{ N}$$

Now let us find the resultant shear load on each rivet.

From Fig. 9.34, we find that angle between F_A and $P_s = \theta_A = 150^\circ$

$$\text{Angle between } F_B \text{ and } P_s = \theta_B = 150^\circ$$

$$\text{Angle between } F_C \text{ and } P_s = \theta_C = 30^\circ$$

$$\text{Angle between } F_D \text{ and } P_s = \theta_D = 30^\circ$$

\therefore Resultant load on rivet A ,

$$\begin{aligned} R_A &= \sqrt{(P_s)^2 + (F_A)^2 + 2P_s \times F_A \times \cos \theta_A} \\ &= \sqrt{(25\,000)^2 + (37\,500)^2 + 2 \times 25\,000 \times 37\,500 \times \cos 150^\circ} \\ &= \sqrt{625 \times 10^6 + 1406 \times 10^6 - 1623.8 \times 10^6} = 15\,492 \text{ N} \end{aligned}$$

Resultant shear load on rivet B,

$$\begin{aligned}
 R_B &= \sqrt{(P_s)^2 + (F_B)^2 + 2P_s \times F_B \times \cos \theta_B} \\
 &= \sqrt{(25\,000)^2 + (12\,500)^2 + 2 \times 25\,000 \times 12\,500 \times \cos 150^\circ} \\
 &= \sqrt{625 \times 10^6 + 156.25 \times 10^6 - 541.25 \times 10^6} = 15\,492 \text{ N}
 \end{aligned}$$

Resultant shear load on rivet C,

$$\begin{aligned}
 R_C &= \sqrt{(P_s)^2 + (F_C)^2 + 2P_s \times F_C \times \cos \theta_C} \\
 &= \sqrt{(25\,000)^2 + (12\,500)^2 + 2 \times 25\,000 \times 12\,500 \times \cos 30^\circ} \\
 &= \sqrt{625 \times 10^6 + 156.25 \times 10^6 + 541.25 \times 10^6} = 36\,366 \text{ N}
 \end{aligned}$$

and resultant shear load on rivet D,

$$\begin{aligned}
 R_D &= \sqrt{(P_s)^2 + (F_D)^2 + 2P_s \times F_D \times \cos \theta_D} \\
 &= \sqrt{(25\,000)^2 + (37\,500)^2 + 2 \times 25\,000 \times 37\,500 \times \cos 30^\circ} \\
 &= \sqrt{625 \times 10^6 + 1406 \times 10^6 + 1623.8 \times 10^6} = 60\,455 \text{ N}
 \end{aligned}$$

The resultant shear load on each rivet may be determined graphically as shown in Fig. 9.35.

From above we see that the maximum resultant shear load is on rivet D. We know that maximum resultant shear load (R_D),

$$\begin{aligned}
 60\,455 &= \frac{\pi}{4} \times d^2 \times \tau = \frac{\pi}{4} \times d^2 \times \frac{\tau_y}{F.S.} \\
 &= \frac{\pi}{4} \times d^2 \times \frac{240}{1.5} = 125.7 d^2
 \end{aligned}$$

$$\therefore d^2 = 60\,455 / 125.7 = 481$$

or

$$d = 21.9 \text{ mm}$$

From Table 9.7, we see that the standard diameter of the rivet hole (d) is 23.5 mm and the corresponding diameter of rivet is 22 mm. **Ans.**

Thickness of the plate

Let

t = Thickness of the plate in mm,

σ_b = Allowable bending stress for the plate

$$= 125 \text{ MPa} = 125 \text{ N/mm}^2 \quad \dots(\text{Given})$$

b = Width of the plate = 240 mm ...(Given)

Consider the weakest section of the plate (*i.e.* the section where it receives four rivet holes of diameter 23.5 mm and thickness t mm) as shown in Fig. 9.36. We know that moment of inertia of the plate about X-X,

$$I_{XX} = \text{M.I. of solid plate about X-X} - \text{*M.I. of 4 rivet holes about X-X}$$

* M.I. of four rivet holes about X-X

$$= \text{M.I. of four rivet holes about their centroidal axis} + 2A(h_1)^2 + 2A(h_2)^2$$

where A = Area of rivet hole.

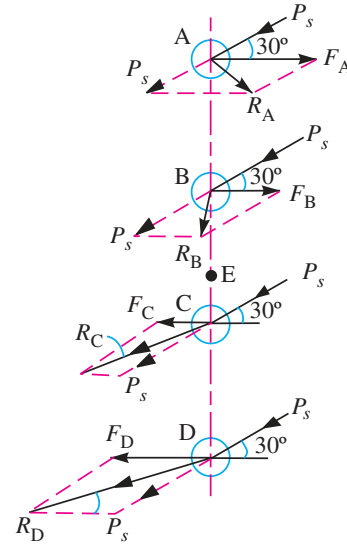

Fig. 9.35

$$= \frac{1}{12} \times t (240)^3 - \left[4 \times \frac{1}{12} \times t (23.5)^3 + 2 \times t \times 23.5 (30^2 + 90^2) \right]$$

$$= 1152 \times 10^3 t - [4326 t + 423 \times 10^3 t] = 724\,674 t \text{ mm}^4$$

Bending moment,

$$M = P \times e = 100 \times 10^3 \times 75$$

$$= 7500 \times 10^3 \text{ N-mm}$$

Distance of neutral axis (X-X) from the top most fibre of the plate,

$$y = \frac{b}{2} = \frac{240}{2} = 120 \text{ mm}$$

We know that $\frac{M}{I} = \frac{\sigma_b}{y}$

or $\frac{7500 \times 10^3}{724\,674 t} = \frac{125}{120}$

$\therefore \frac{10.35}{t} = 1.04$ or $t = \frac{10.35}{1.04} = 9.95$ say 10 mm **Ans.**

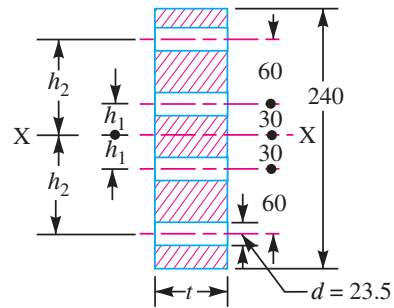

All dimensions in mm.

Fig. 9.36

EXERCISES

1. A single riveted lap joint is made in 15 mm thick plates with 20 mm diameter rivets. Determine the strength of the joint, if the pitch of rivets is 60 mm. Take $\sigma_t = 120$ MPa; $\tau = 90$ MPa and $\sigma_c = 160$ MPa. **[Ans. 28 280 N]**
2. Two plates 16 mm thick are joined by a double riveted lap joint. The pitch of each row of rivets is 90 mm. The rivets are 25 mm in diameter. The permissible stresses are as follows :
 $\sigma_t = 140$ MPa ; $\tau = 110$ MPa and $\sigma_c = 240$ MPa
 Find the efficiency of the joint. **[Ans. 53.5%]**
3. A single riveted double cover butt joint is made in 10 mm thick plates with 20 mm diameter rivets with a pitch of 60 mm. Calculate the efficiency of the joint, if
 $\sigma_t = 100$ MPa ; $\tau = 80$ MPa and $\sigma_c = 160$ MPa. **[Ans. 53.8%]**
4. A double riveted double cover butt joint is made in 12 mm thick plates with 18 mm diameter rivets. Find the efficiency of the joint for a pitch of 80 mm, if
 $\sigma_t = 115$ MPa ; $\tau = 80$ MPa and $\sigma_c = 160$ MPa. **[Ans. 62.6%]**
5. A double riveted lap joint with chain riveting is to be made for joining two plates 10 mm thick. The allowable stresses are : $\sigma_t = 60$ MPa ; $\tau = 50$ MPa and $\sigma_c = 80$ MPa. Find the rivet diameter, pitch of rivets and distance between rows of rivets. Also find the efficiency of the joint. **[Ans. d = 20 mm ; p = 73 mm ; p_b = 38 mm ; η = 71.7%]**
6. A triple riveted lap joint with zig-zag riveting is to be designed to connect two plates of 6 mm thickness. Determine the dia. of rivet, pitch of rivets and distance between the rows of rivet. Indicate how the joint will fail. Assume : $\sigma_t = 120$ MPa ; $\tau = 100$ MPa and $\sigma_c = 150$ MPa. **[Ans. d = 14 mm ; p = 78 mm ; p_b = 35.2 mm]**
7. A double riveted butt joint, in which the pitch of the rivets in the outer rows is twice that in the inner rows, connects two 16 mm thick plates with two cover plates each 12 mm thick. The diameter of rivets is 22 mm. Determine the pitches of the rivets in the two rows if the working stresses are not to exceed the following limits:

338 ■ A Textbook of Machine Design

Tensile stress in plates = 100 MPa ; Shear stress in rivets = 75 MPa; and bearing stress in rivets and plates = 150 MPa.

Make a fully dimensioned sketch of the joint by showing at least two views.

[Ans. 107 mm, 53.5 mm]

8. Design a double riveted double strap butt joint for the longitudinal seam of a boiler shell, 750 mm in diameter, to carry a maximum steam pressure of 1.05 N/mm² gauge. The allowable stresses are :

$$\sigma_t = 35 \text{ MPa}; \tau = 28 \text{ MPa and } \sigma_c = 52.5 \text{ MPa}$$

Assume the efficiency of the joint as 75%.

[Ans. $t = 16 \text{ mm}$; $d = 25 \text{ mm}$; $p = 63 \text{ mm}$; $p_b = 37.5 \text{ mm}$; $t_1 = t_2 = 10 \text{ mm}$; $m = 37.5 \text{ mm}$]

9. Design a triple riveted double strap butt joint with chain riveting for a boiler of 1.5 m diameter and carrying a pressure of 1.2 N/mm². The allowable stresses are :

$$\sigma_t = 105 \text{ MPa}; \tau = 77 \text{ MPa and } \sigma_c = 162.5 \text{ MPa} \quad \text{[Ans. } d = 20 \text{ mm; } p = 50 \text{ mm]}$$

10. Design a triple riveted longitudinal double strap butt joint with unequal straps for a boiler. The inside diameter of the longest course of the drum is 1.3 metres. The joint is to be designed for a steam pressure of 2.4 N/mm². The working stresses to be used are :

$$\sigma_t = 77 \text{ MPa}; \tau = 62 \text{ MPa and } \sigma_c = 120 \text{ MPa}$$

Assume the efficiency of the joint as 81%.

[Ans. $t = 26 \text{ mm}$; $d = 31.5 \text{ mm}$; $p = 200 \text{ mm}$; $t_1 = 19.5 \text{ mm}$; $t_2 = 16.5 \text{ mm}$; $m = 47.5 \text{ mm}$]

11. Design the longitudinal and circumferential joint for a boiler whose diameter is 2.4 metres and is subjected to a pressure of 1 N/mm². The longitudinal joint is a triple riveted butt joint with an efficiency of about 85% and the circumferential joint is a double riveted lap joint with an efficiency of about 70%. The pitch in the outer rows of the rivets is to be double than in the inner rows and the width of the cover plates is unequal. The allowable stresses are :

$$\sigma_t = 77 \text{ MPa}; \tau = 56 \text{ MPa and } \sigma_c = 120 \text{ MPa}$$

Assume that the resistance of rivets in double shear is 1.875 times that of single shear. Draw the complete joint.

12. A triple riveted butt joint with equal double cover plates (zig-zag riveting) is used for the longitudinal joint of a Lancashire boiler of 2.5 m internal diameter. The working steam pressure is 1.12 N/mm² and the efficiency of the joint is 85 per cent. Calculate the plate thickness for mild steel of 460 MPa ultimate tensile strength. Assume ratio of tensile to shear stresses as 7/6 and factor of safety 4. The resistance of the rivets in double shear is to be taken as 1.875 times that of single shear. Design a suitable circumferential joint also.

13. Two lengths of mild steel flat tie bars 200 mm × 10 mm are to be connected by a double riveted double cover butt joint, using 24 mm diameter rivets. Design the joint, if the allowable working stresses are 112 MPa in tension, 84 MPa in shear and 200 MPa in crushing.

[Ans. $n = 5$; $\eta = 88\%$]

14. Two mild steel tie bars for a bridge structure are to be joined by a double cover butt joint. The thickness of the tie bar is 20 mm and carries a tensile load of 400 kN. Design the joint if the allowable stresses are : $\sigma_t = 90 \text{ MPa}$; $\tau = 75 \text{ MPa}$ and $\sigma_c = 150 \text{ MPa}$.

Assume the strength of rivet in double shear to be 1.75 times that of in single shear.

[Ans. $b = 150 \text{ mm}$; $d = 27 \text{ mm}$; $n = 6$; $\eta = 90\%$]

15. Two lengths of mild steel tie rod having width 200 mm are to be connected by means of Lozenge joint with two cover plates to withstand a tensile load of 180 kN. Completely design the joint, if the permissible stresses are 80 MPa in tension; 65 MPa in shear and 160 MPa in crushing. Draw a neat sketch of the joint.

[Ans. $t = 13 \text{ mm}$; $d = 22 \text{ mm}$; $n = 5$; $\eta = 86.5\%$]

16. A bracket is supported by means of 4 rivets of same size, as shown in Fig. 9.37. Determine the diameter of the rivet if the maximum shear stress is 140 MPa.

[Ans. 16 mm]

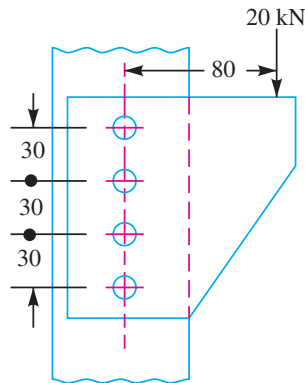

All dimensions in mm.

Fig. 9.37

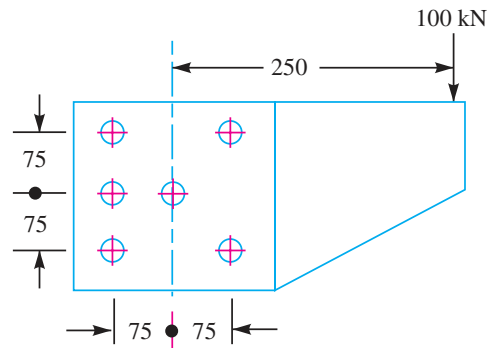

All dimensions in mm.

Fig. 9.38

17. A bracket is riveted to a column by 6 rivets of equal size as shown in Fig. 9.38. It carries a load of 100 kN at a distance of 250 mm from the column. If the maximum shear stress in the rivet is limited to 63 MPa, find the diameter of the rivet. **[Ans. 41 mm]**
18. A bracket in the form of a plate is fitted to a column by means of four rivets of the same size, as shown in Fig. 9.39. A load of 100 kN is applied to the bracket at an angle of 60° to the horizontal and the line of action of the load passes through the centre of the bottom rivet. If the maximum shear stress for the material of the rivet is 70 MPa, find the diameter of rivets. What will be the thickness of the plate if the crushing stress is 100 MPa? **[Ans. 29 mm; 1.5 mm]**

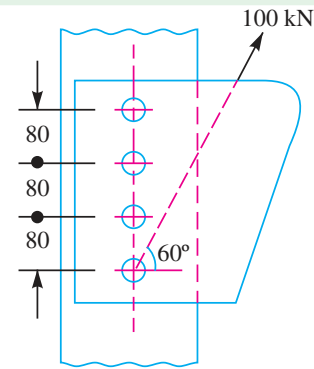

All dimensions in mm.

Fig. 9.39

QUESTIONS

1. What do you understand by the term riveted joint? Explain the necessity of such a joint.
2. What are the various permanent and detachable fastenings? Give a complete list with the different types of each category.
3. Classify the rivet heads according to Indian standard specifications.
4. What is the material used for rivets?
5. Enumerate the different types of riveted joints and rivets.
6. What is an economical joint and where does it find applications?
7. What is the difference between caulking and fullering? Explain with the help of neat sketches.
8. Show by neat sketches the various ways in which a riveted joint may fail.
9. What do you understand by the term 'efficiency of a riveted joint'? According to I.B.R., what is the highest efficiency required of a riveted joint?
10. Explain the procedure for designing a longitudinal and circumferential joint for a boiler.
11. Describe the procedure for designing a lozenge joint.
12. What is an eccentric riveted joint? Explain the method adopted for designing such a joint?

OBJECTIVE TYPE QUESTIONS

1. A rivet is specified by

(a) shank diameter	(b) length of rivet
(c) type of head	(d) length of tail

340 ■ A Textbook of Machine Design

2. The diameter of the rivet hole is usually the nominal diameter of the rivet.
(a) equal to (b) less than (c) more than
3. The rivet head used for boiler plate riveting is usually
(a) snap head (b) pan head
(c) counter sunk head (d) conical head
4. According to Unwin's formula, the relation between diameter of rivet hole (d) and thickness of plate (t) is given by
(a) $d = t$ (b) $d = 1.6 \sqrt{t}$
(c) $d = 2t$ (d) $d = 6t$
where d and t are in mm.
5. A line joining the centres of rivets and parallel to the edge of the plate is known as
(a) back pitch (b) marginal pitch
(c) gauge line (d) pitch line
6. The centre to centre distance between two consecutive rivets in a row, is called
(a) margin (b) pitch
(c) back pitch (d) diagonal pitch
7. The objective of caulking in a riveted joint is to make the joint
(a) free from corrosion (b) stronger in tension
(c) free from stresses (d) leak-proof
8. A lap joint is always inshear.
(a) single (b) double
9. A double strap butt joint (with equal straps) is
(a) always in single shear (b) always in double shear
(c) either in single shear or double shear (d) any one of these
10. Which of the following riveted butt joints with double straps should have the highest efficiency as per Indian Boiler Regulations?
(a) Single riveted (b) Double riveted
(c) Triple riveted (d) Quadruple riveted
11. If the tearing efficiency of a riveted joint is 50%, then ratio of diameter of rivet hole to the pitch of rivets is
(a) 0.20 (b) 0.30
(c) 0.50 (d) 0.60
12. The strength of the unriveted or solid plate per pitch length is equal to
(a) $p \times d \times \sigma_t$ (b) $p \times t \times \sigma_t$
(c) $(p - t) d \times \sigma_t$ (d) $(p - d) t \times \sigma_t$
13. The longitudinal joint in boilers is used to get the required
(a) length of boiler (b) diameter of boiler
(c) length and diameter of boiler (d) efficiency of boiler
14. For longitudinal joint in boilers, the type of joint used is
(a) lap joint with one ring overlapping the other (b) butt joint with single cover plate
(c) butt joint with double cover plates (d) any one of these
15. According to Indian standards, the diameter of rivet hole for a 24 mm diameter of rivet, should be
(a) 23 mm (b) 24 mm
(c) 25 mm (d) 26 mm

ANSWERS

- | | | | | |
|---------|---------|---------|---------|---------|
| 1. (a) | 2. (c) | 3. (a) | 4. (d) | 5. (b) |
| 6. (b) | 7. (d) | 8. (a) | 9. (b) | 10. (d) |
| 11. (c) | 12. (b) | 13. (b) | 14. (c) | 15. (c) |

$$P_t = (p - d) t \times \sigma_t = (100 - 25) 20 \times 120 = 180\,000 \text{ N}$$

$$P_c = n \times d \times t \times \sigma_c = 2 \times 25 \times 20 \times 150 = 150\,000 \text{ N}$$

$$\begin{aligned} \therefore \text{Strength of the joint} \\ &= \text{Least of } P_t, P_s \text{ and } P_c \\ &= 150\,000 \text{ N} \end{aligned}$$

Efficiency of the joint

We know that the strength of the unriveted or solid plate,

$$\begin{aligned} P &= p \times t \times \sigma_t = 100 \times 20 \times 120 \\ &= 240\,000 \text{ N} \end{aligned}$$

$$\begin{aligned} \therefore \text{Efficiency of the joint} \\ &= \frac{\text{Least of } P_t, P_s \text{ and } P_c}{P} = \frac{150\,000}{240\,000} \\ &= 0.625 \text{ or } 62.5\% \text{ Ans.} \end{aligned}$$

342 ■ A Textbook of Machine Design

(c) $d = 2t$

(d) $d = 6t$

(c) $(p - t)d \times \sigma_t$

(d) any one of these

(d) $(p - d)t \times \sigma_t$

(c) butt joint with double cover plates

(d) any one of these

Welded Joints

1. Introduction.
2. Advantages and Disadvantages of Welded Joints over Riveted Joints.
3. Welding Processes.
4. Fusion Welding.
5. Thermit Welding.
6. Gas Welding.
7. Electric Arc Welding.
8. Forge Welding.
9. Types of Welded Joints.
10. Lap Joint.
11. Butt Joint.
12. Basic Weld Symbols.
13. Supplementary Weld Symbols.
14. Elements of a Weld Symbol.
15. Standard Location of Elements of a Welding Symbol.
16. Strength of Transverse Fillet Welded Joints.
17. Strength of Parallel Fillet Welded Joints.
18. Special Cases of Fillet Welded Joints.
19. Strength of Butt Joints.
20. Stresses for Welded Joints.
21. Stress Concentration Factor for Welded Joints.
22. Axially Loaded Unsymmetrical Welded Sections.
23. Eccentrically Loaded Welded Joints.
24. Polar Moment of Inertia and Section Modulus of Welds.



10.1 Introduction

A welded joint is a permanent joint which is obtained by the fusion of the edges of the two parts to be joined together, with or without the application of pressure and a filler material. The heat required for the fusion of the material may be obtained by burning of gas (in case of gas welding) or by an electric arc (in case of electric arc welding). The latter method is extensively used because of greater speed of welding.

Welding is extensively used in fabrication as an alternative method for casting or forging and as a replacement for bolted and riveted joints. It is also used as a repair medium *e.g.* to reunite metal at a crack, to build up a small part that has broken off such as gear tooth or to repair a worn surface such as a bearing surface.

10.2 Advantages and Disadvantages of Welded Joints over Riveted Joints

Following are the advantages and disadvantages of welded joints over riveted joints.

Advantages

1. The welded structures are usually lighter than riveted structures. This is due to the reason, that in welding, gussets or other connecting components are not used.
2. The welded joints provide maximum efficiency (may be 100%) which is not possible in case of riveted joints.
3. Alterations and additions can be easily made in the existing structures.
4. As the welded structure is smooth in appearance, therefore it looks pleasing.
5. In welded connections, the tension members are not weakened as in the case of riveted joints.
6. A welded joint has a great strength. Often a welded joint has the strength of the parent metal itself.
7. Sometimes, the members are of such a shape (*i.e.* circular steel pipes) that they afford difficulty for riveting. But they can be easily welded.
8. The welding provides very rigid joints. This is in line with the modern trend of providing rigid frames.
9. It is possible to weld any part of a structure at any point. But riveting requires enough clearance.
10. The process of welding takes less time than the riveting.

Disadvantages

1. Since there is an uneven heating and cooling during fabrication, therefore the members may get distorted or additional stresses may develop.
2. It requires a highly skilled labour and supervision.
3. Since no provision is kept for expansion and contraction in the frame, therefore there is a possibility of cracks developing in it.
4. The inspection of welding work is more difficult than riveting work.

10.3 Welding Processes

The welding processes may be broadly classified into the following two groups:

1. Welding processes that use heat alone *e.g.* fusion welding.
2. Welding processes that use a combination of heat and pressure *e.g.* forge welding.

These processes are discussed in detail, in the following pages.

10.4 Fusion Welding

In case of fusion welding, the parts to be jointed are held in position while the molten metal is supplied to the joint. The molten metal may come from the parts themselves (*i.e.* parent metal) or filler metal which normally have the composition of the parent metal. The joint surface become plastic or even molten because of the heat



Fusion welding at 245°C produces permanent molecular bonds between sections.

from the molten filler metal or other source. Thus, when the molten metal solidifies or fuses, the joint is formed.

The fusion welding, according to the method of heat generated, may be classified as:

1. Thermit welding,
2. Gas welding, and
3. Electric arc welding.

10.5 Thermit Welding

In thermit welding, a mixture of iron oxide and aluminium called *thermit* is ignited and the iron oxide is reduced to molten iron. The molten iron is poured into a mould made around the joint and fuses with the parts to be welded. A major advantage of the thermit welding is that all parts of weld section are molten at the same time and the weld cools almost uniformly. This results in a minimum problem with residual stresses. It is fundamentally a melting and casting process.

The thermit welding is often used in joining iron and steel parts that are too large to be manufactured in one piece, such as rails, truck frames, locomotive frames, other large sections used on steam and rail roads, for stern frames, rudder frames etc. In steel mills, thermit electric welding is employed to replace broken gear teeth, to weld new necks on rolls and pinions, and to repair broken shears.

10.6 Gas Welding

A gas welding is made by applying the flame of an oxy-acetylene or hydrogen gas from a welding torch upon the surfaces of the prepared joint. The intense heat at the white cone of the flame heats up the local surfaces to fusion point while the operator manipulates a welding rod to supply the metal for the weld. A flux is being used to remove the slag. Since the heating rate in gas welding is slow, therefore it can be used on thinner materials.

10.7 Electric Arc Welding

In electric arc welding, the work is prepared in the same manner as for gas welding. In this case the filler metal is supplied by metal welding electrode. The operator, with his eyes and face protected, strikes an arc by touching the work of base metal with the electrode. The base metal in the path of the arc stream is melted, forming a pool of molten metal, which seems to be forced out of the pool by the blast from the arc, as shown in Fig. 10.1. A small depression is formed in the base metal and the molten metal is deposited around the edge of this depression, which is called the *arc crater*. The slag is brushed off after the joint has cooled.

The arc welding does not require the metal to be preheated and since the temperature of the arc is quite high, therefore the fusion of the metal is almost instantaneous. There are two kinds of arc weldings depending upon the type of electrode.

1. Un-shielded arc welding, and
2. Shielded arc welding.

When a large electrode or filler rod is used for welding, it is then said to be *un-shielded arc welding*. In this case, the deposited weld metal while it is hot will absorb oxygen and nitrogen from the atmosphere. This decreases the strength of weld metal and lower its ductility and resistance to corrosion.

In *shielded arc welding*, the welding rods coated with solid material are used, as shown in Fig. 10.1. The resulting projection of coating focuses a concentrated arc stream, which protects the globules of metal from the air and prevents the absorption of large amounts of harmful oxygen and nitrogen.

10.8 Forge Welding

In forge welding, the parts to be jointed are first heated to a proper temperature in a furnace or

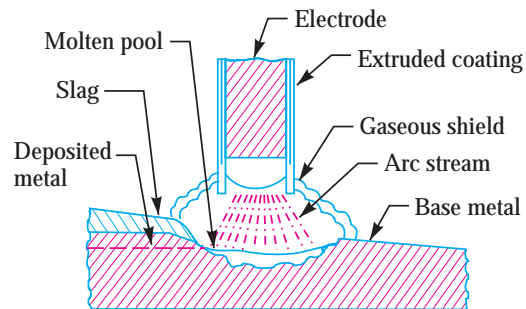

Fig. 10.1. Shielded electric arc welding.

forge and then hammered. This method of welding is rarely used now-a-days. An *electric-resistance welding* is an example of forge welding.

In this case, the parts to be joined are pressed together and an electric current is passed from one part to the other until the metal is heated to the fusion temperature of the joint. The principle of applying heat and pressure, either sequentially or simultaneously, is widely used in the processes known as **spot, seam, projection, upset and flash welding*.



Forge welding.

10.9 Types of Welded Joints

Following two types of welded joints are important from the subject point of view:

1. Lap joint or fillet joint, and 2. Butt joint.

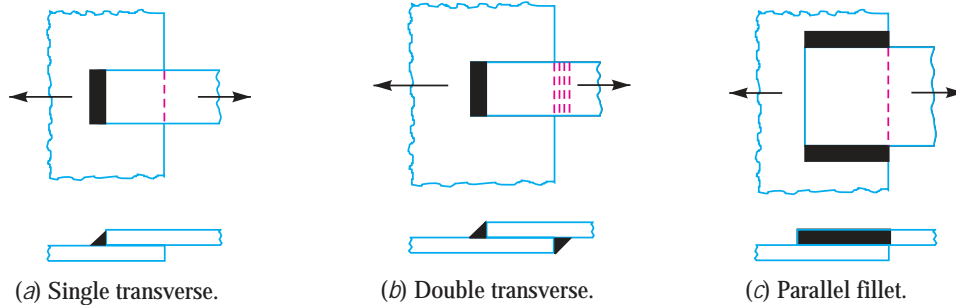

Fig. 10.2. Types of lap or fillet joints.

10.10 Lap Joint

The lap joint or the fillet joint is obtained by overlapping the plates and then welding the edges of the plates. The cross-section of the fillet is approximately triangular. The fillet joints may be

1. Single transverse fillet, 2. Double transverse fillet, and 3. Parallel fillet joints.

The fillet joints are shown in Fig. 10.2. A single transverse fillet joint has the disadvantage that the edge of the plate which is not welded can buckle or warp out of shape.

10.11 Butt Joint

The butt joint is obtained by placing the plates edge to edge as shown in Fig. 10.3. In butt welds, the plate edges do not require bevelling if the thickness of plate is less than 5 mm. On the other hand, if the plate thickness is 5 mm to 12.5 mm, the edges should be bevelled to V or U-groove on both sides.

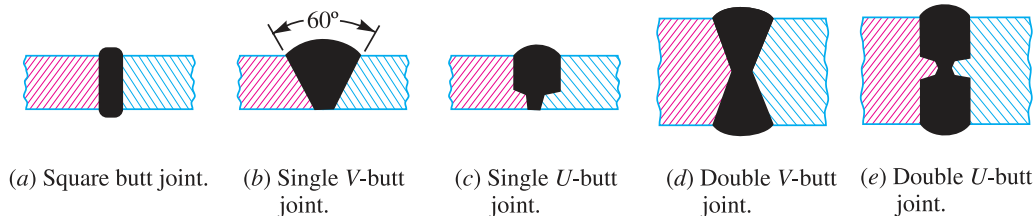

Fig. 10.3. Types of butt joints.

* For further details, refer author's popular book 'A Textbook of Workshop Technology'.

The butt joints may be

1. Square butt joint,
2. Single V-butt joint
3. Single U-butt joint,
4. Double V-butt joint, and
5. Double U-butt joint.

These joints are shown in Fig. 10.3.

The other type of welded joints are corner joint, edge joint and T-joint as shown in Fig. 10.4.

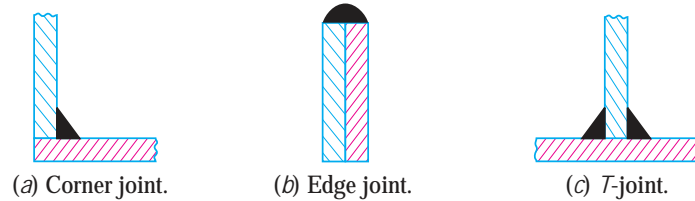

Fig. 10.4. Other types of welded joints.

The main considerations involved in the selection of weld type are:











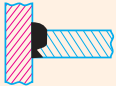















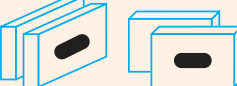

1. The shape of the welded component required,
2. The thickness of the plates to be welded, and
3. The direction of the forces applied.

10.12 Basic Weld Symbols

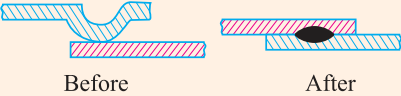
The basic weld symbols according to IS : 813 – 1961 (Reaffirmed 1991) are shown in the following table.

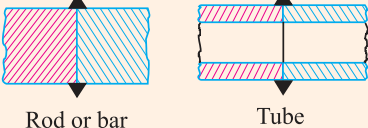
Table 10.1. Basic weld symbols.

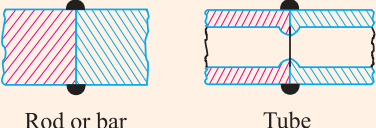









S. No.	Form of weld	Sectional representation	Symbol
1.	Fillet		
2.	Square butt		
3.	Single-V butt		
4.	Double-V butt		
5.	Single-U butt		
6.	Double-U butt		
7.	Single bevel butt		
8.	Double bevel butt		

S. No.	Form of weld	Sectional representation	Symbol
9.	Single-J butt		
10.	Double-J butt		
11.	Bead (edge or seal)		
12.	Stud		
13.	Sealing run		
14.	Spot		
15.	Seam		
16.	Mashed seam		
17.	Plug		
18.	Backing strip		
19.	Stitch		
20.	Projection		
21.	Flash		
22.	Butt resistance or pressure (upset)		

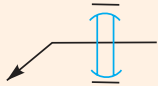
10.13 Supplementary Weld Symbols

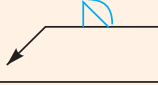
In addition to the above symbols, some supplementary symbols, according to IS:813 – 1961 (Reaffirmed 1991), are also used as shown in the following table.

Table 10.2. Supplementary weld symbols.

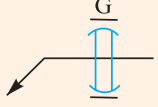
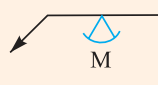
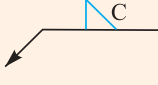
S. No.	Particulars	Drawing representation	Symbol
1.	Weld all round		
2.	Field weld		
3.	Flush contour		
4.	Convex contour		
5.	Concave contour		
6.	Grinding finish		G
7.	Machining finish		M
8.	Chipping finish		C

10.14 Elements of a Welding Symbol

A welding symbol consists of the following eight elements:

1. Reference line,
2. Arrow,
3. Basic weld symbols,
4. Dimensions and other data,
5. Supplementary symbols,
6. Finish symbols,
7. Tail, and
8. Specification, process or other references.

10.15 Standard Location of Elements of a Welding Symbol

According to Indian Standards, IS: 813 – 1961 (Reaffirmed 1991), the elements of a welding symbol shall have standard locations with respect to each other.

The arrow points to the location of weld, the basic symbols with dimensions are located on one or both sides of reference line. The specification if any is placed in the tail of arrow. Fig. 10.5 shows the standard locations of welding symbols represented on drawing.

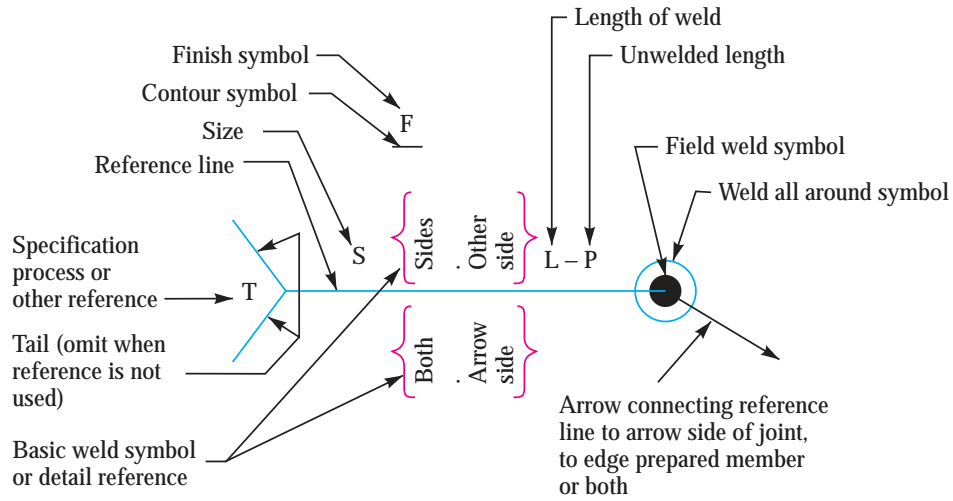

Fig. 10.5. Standard location of welding symbols.

Some of the examples of welding symbols represented on drawing are shown in the following table.

Table 10.3. Representation of welding symbols.

S. No.	Desired weld	Representation on drawing
1.	Fillet-weld each side of Tee-convex contour	
2.	Single V-butt weld -machining finish	
3.	Double V- butt weld	
4.	Plug weld - 30° Groove-angle-flush contour	
5.	Staggered intermittent fillet welds	

10.16 Strength of Transverse Fillet Welded Joints

We have already discussed that the fillet or lap joint is obtained by overlapping the plates and then welding the edges of the plates. The transverse fillet welds are designed for tensile strength. Let us consider a single and double transverse fillet welds as shown in Fig. 10.6 (a) and (b) respectively.

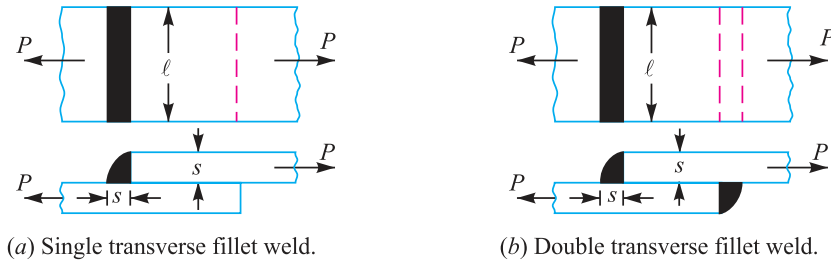

Fig. 10.6. Transverse fillet welds.

In order to determine the strength of the fillet joint, it is assumed that the section of fillet is a right angled triangle ABC with hypotenuse AC making equal angles with other two sides AB and BC . The enlarged view of the fillet is shown in Fig. 10.7. The length of each side is known as **leg or size of the weld** and the perpendicular distance of the hypotenuse from the intersection of legs (i.e. BD) is known as **throat thickness**. The minimum area of the weld is obtained at the throat BD , which is given by the product of the throat thickness and length of weld.

- Let
- t = Throat thickness (BD),
 - s = Leg or size of weld,
 - = Thickness of plate, and
 - l = Length of weld,

From Fig. 10.7, we find that the throat thickness,

$$t = s \times \sin 45^\circ = 0.707 s$$

∴ *Minimum area of the weld or throat area,

$$\begin{aligned} A &= \text{Throat thickness} \times \\ &\quad \text{Length of weld} \\ &= t \times l = 0.707 s \times l \end{aligned}$$

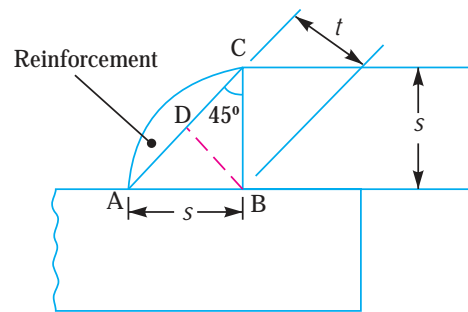

Fig. 10.7. Enlarged view of a fillet weld.

If σ_t is the allowable tensile stress for the weld metal, then the tensile strength of the joint for single fillet weld,

$$P = \text{Throat area} \times \text{Allowable tensile stress} = 0.707 s \times l \times \sigma_t$$

and tensile strength of the joint for double fillet weld,

$$P = 2 \times 0.707 s \times l \times \sigma_t = 1.414 s \times l \times \sigma_t$$

Note: Since the weld is weaker than the plate due to slag and blow holes, therefore the weld is given a reinforcement which may be taken as 10% of the plate thickness.

10.17 Strength of Parallel Fillet Welded Joints

The parallel fillet welded joints are designed for shear strength. Consider a double parallel fillet welded joint as shown in Fig. 10.8 (a). We have already discussed in the previous article, that the minimum area of weld or the throat area,

$$A = 0.707 s \times l$$

* The minimum area of the weld is taken because the stress is maximum at the minimum area.

If τ is the allowable shear stress for the weld metal, then the shear strength of the joint for single parallel fillet weld,

$$P = \text{Throat area} \times \text{Allowable shear stress} = 0.707 s \times l \times \tau$$

and shear strength of the joint for double parallel fillet weld,

$$P = 2 \times 0.707 \times s \times l \times \tau = 1.414 s \times l \times \tau$$

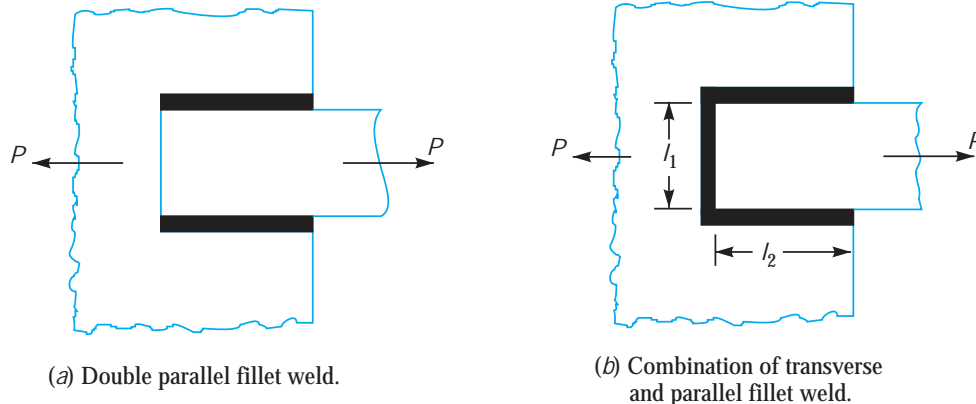

Fig. 10.8

Notes: 1. If there is a combination of single transverse and double parallel fillet welds as shown in Fig. 10.8 (b), then the strength of the joint is given by the sum of strengths of single transverse and double parallel fillet welds. Mathematically,

$$P = 0.707s \times l_1 \times \sigma_t + 1.414 s \times l_2 \times \tau$$

where l_1 is normally the width of the plate.

2. In order to allow for starting and stopping of the bead, 12.5 mm should be added to the length of each weld obtained by the above expression.

3. For reinforced fillet welds, the throat dimension may be taken as $0.85 t$.

Example 10.1. A plate 100 mm wide and 10 mm thick is to be welded to another plate by means of double parallel fillets. The plates are subjected to a static load of 80 kN. Find the length of weld if the permissible shear stress in the weld does not exceed 55 MPa.

Solution. Given: *Width = 100 mm ; Thickness = 10 mm ; $P = 80 \text{ kN} = 80 \times 10^3 \text{ N}$; $\tau = 55 \text{ MPa} = 55 \text{ N/mm}^2$

Let l = Length of weld, and

s = Size of weld = Plate thickness = 10 mm
... (Given)

We know that maximum load which the plates can carry for double parallel fillet weld (P),

$$80 \times 10^3 = 1.414 \times s \times l \times \tau = 1.414 \times 10 \times l \times 55 = 778 l$$

$$\therefore l = 80 \times 10^3 / 778 = 103 \text{ mm}$$

Adding 12.5 mm for starting and stopping of weld run, we have

$$l = 103 + 12.5 = 115.5 \text{ mm} \text{ Ans.}$$



Electric arc welding

* Superfluous data.

10.18 Special Cases of Fillet Welded Joints

The following cases of fillet welded joints are important from the subject point of view.

1. Circular fillet weld subjected to torsion. Consider a circular rod connected to a rigid plate by a fillet weld as shown in Fig. 10.9.

- Let
- d = Diameter of rod,
 - r = Radius of rod,
 - T = Torque acting on the rod,
 - s = Size (or leg) of weld,
 - t = Throat thickness,
 - * J = Polar moment of inertia of the weld section = $\frac{\pi t d^3}{4}$

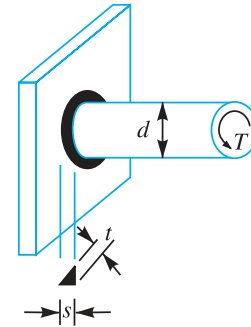

Fig. 10.9. Circular fillet weld subjected to torsion.

We know that shear stress for the material,

$$\begin{aligned} \tau &= \frac{T.r}{J} = \frac{T \times d/2}{J} \\ &= \frac{T \times d/2}{\pi t d^3/4} = \frac{2T}{\pi t d^2} \end{aligned} \quad \dots \left(\because \frac{T}{J} = \frac{\tau}{r} \right)$$

This shear stress occurs in a horizontal plane along a leg of the fillet weld. The maximum shear stress occurs on the throat of weld which is inclined at 45° to the horizontal plane.

\therefore Length of throat, $t = s \sin 45^\circ = 0.707 s$
and maximum shear stress,

$$\tau_{max} = \frac{2T}{\pi \times 0.707 s \times d^2} = \frac{2.83 T}{\pi s d^2}$$

2. Circular fillet weld subjected to bending moment. Consider a circular rod connected to a rigid plate by a fillet weld as shown in Fig. 10.10.

- Let
- d = Diameter of rod,
 - M = Bending moment acting on the rod,
 - s = Size (or leg) of weld,
 - t = Throat thickness,
 - ** Z = Section modulus of the weld section = $\frac{\pi t d^2}{4}$

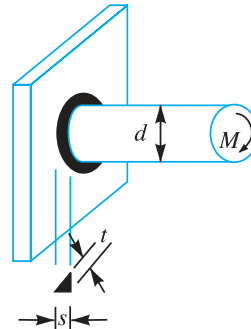

Fig. 10.10. Circular fillet weld subjected to bending moment.

We know that the bending stress,

$$\sigma_b = \frac{M}{Z} = \frac{M}{\pi t d^2/4} = \frac{4M}{\pi t d^2}$$

This bending stress occurs in a horizontal plane along a leg of the fillet weld. The maximum bending stress occurs on the throat of the weld which is inclined at 45° to the horizontal plane.

\therefore Length of throat, $t = s \sin 45^\circ = 0.707 s$
and maximum bending stress,

$$\sigma_{b(max)} = \frac{4M}{\pi \times 0.707 s \times d^2} = \frac{5.66 M}{\pi s d^2}$$

* See Art, 10.24.

** See Art, 10.24.

3. Long fillet weld subjected to torsion. Consider a vertical plate attached to a horizontal plate by two identical fillet welds as shown in Fig. 10.11.

Let T = Torque acting on the vertical plate,
 l = Length of weld,
 s = Size (or leg) of weld,
 t = Throat thickness, and
 J = Polar moment of inertia of the weld section

$$= 2 \times \frac{t \times l^3}{12} = \frac{t \times l^3}{6} \dots$$

(\therefore of both sides weld)

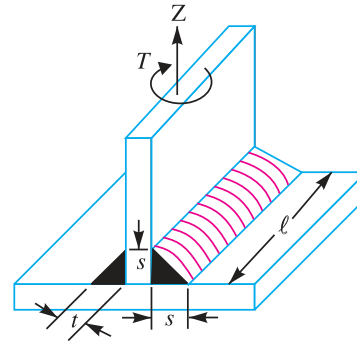

Fig. 10.11. Long fillet weld subjected to torsion.

It may be noted that the effect of the applied torque is to rotate the vertical plate about the Z-axis through its mid point. This rotation is resisted by shearing stresses developed between two fillet welds and the horizontal plate. It is assumed that these horizontal shearing stresses vary from zero at the Z-axis and maximum at the ends of the plate. This variation of shearing stress is analogous to the variation of normal stress over the depth (l) of a beam subjected to pure bending.

$$\therefore \text{Shear stress, } \tau = \frac{T \times l/2}{t \times l^3 / 6} = \frac{3T}{t \times l^2}$$

The maximum shear stress occurs at the throat and is given by

$$\tau_{max} = \frac{3T}{0.707 s \times l^2} = \frac{4.242 T}{s \times l^2}$$

Example 10.2. A 50 mm diameter solid shaft is welded to a flat plate by 10 mm fillet weld as shown in Fig. 10.12. Find the maximum torque that the welded joint can sustain if the maximum shear stress intensity in the weld material is not to exceed 80 MPa.

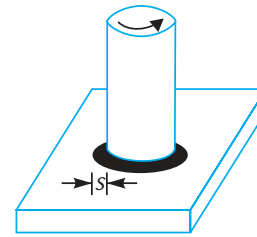

Fig. 10.12

Solution. Given : $d = 50 \text{ mm}$; $s = 10 \text{ mm}$; $\tau_{max} = 80 \text{ MPa} = 80 \text{ N/mm}^2$
 Let T = Maximum torque that the welded joint can sustain.

We know that the maximum shear stress (τ_{max}),

$$80 = \frac{2.83 T}{\pi s \times d^2} = \frac{2.83 T}{\pi \times 10 (50)^2} = \frac{2.83 T}{78550}$$

$$\therefore T = 80 \times 78550 / 2.83 = 2.22 \times 10^6 \text{ N-mm} = 2.22 \text{ kN-m} \text{ Ans.}$$

Example 10.3. A plate 1 m long, 60 mm thick is welded to another plate at right angles to each other by 15 mm fillet weld, as shown in Fig. 10.13. Find the maximum torque that the welded joint can sustain if the permissible shear stress intensity in the weld material is not to exceed 80 MPa.

Solution. Given: $l = 1 \text{ m} = 1000 \text{ mm}$; Thickness = 60 mm ;
 $s = 15 \text{ mm}$; $\tau_{max} = 80 \text{ MPa} = 80 \text{ N/mm}^2$

Let T = Maximum torque that the welded joint can sustain.

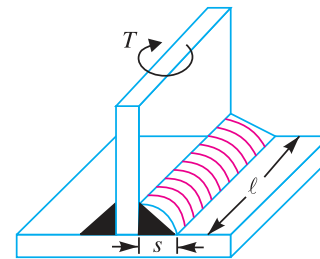

Fig. 10.13

We know that the maximum shear stress (τ_{max}),

$$80 = \frac{4.242 T}{s \times l^2} = \frac{4.242 T}{15 (1000)^2} = \frac{0.283 T}{10^6}$$

∴ $T = 80 \times 10^6 / 0.283 = 283 \times 10^6 \text{ N-mm} = 283 \text{ kN-m}$ **Ans.**

10.19 Strength of Butt Joints

The butt joints are designed for tension or compression. Consider a single V-butt joint as shown in Fig. 10.14 (a).

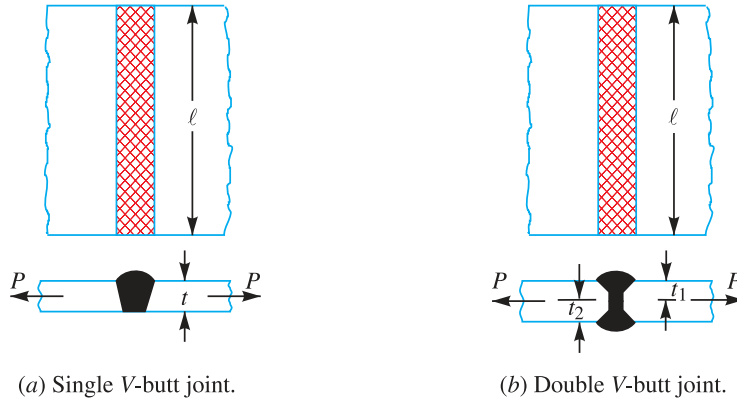

Fig. 10.14. Butt joints.

In case of butt joint, the length of leg or size of weld is equal to the throat thickness which is equal to thickness of plates.

∴ Tensile strength of the butt joint (single-V or square butt joint),

$$P = t \times l \times \sigma_t$$

where

l = Length of weld. It is generally equal to the width of plate.

and tensile strength for double-V butt joint as shown in Fig. 10.14 (b) is given by

$$P = (t_1 + t_2) l \times \sigma_t$$

where

t_1 = Throat thickness at the top, and

t_2 = Throat thickness at the bottom.

It may be noted that size of the weld should be greater than the thickness of the plate, but it may be less. The following table shows recommended minimum size of the welds.

Table 10.4. Recommended minimum size of welds.

Thickness of plate (mm)	3 – 5	6 – 8	10 – 16	18 – 24	26 – 55	Over 58
Minimum size of weld (mm)	3	5	6	10	14	20

10.20 Stresses in Welded Joints

The stresses in welded joints are difficult to determine because of the variable and unpredictable parameters like homogeneity of the weld metal, thermal stresses in the welds, changes of physical properties due to high rate of cooling etc. The stresses are obtained, on the following assumptions:

1. The load is distributed uniformly along the entire length of the weld, and
2. The stress is spread uniformly over its effective section.

The following table shows the stresses for welded joints for joining ferrous metals with mild steel electrode under steady and fatigue or reversed load.

Table 10.5. Stresses for welded joints.

Type of weld	Bare electrode		Coated electrode	
	Steady load (MPa)	Fatigue load (MPa)	Steady load (MPa)	Fatigue load (MPa)
1. Fillet welds (All types)	80	21	98	35
2. Butt welds				
Tension	90	35	110	55
Compression	100	35	125	55
Shear	55	21	70	35

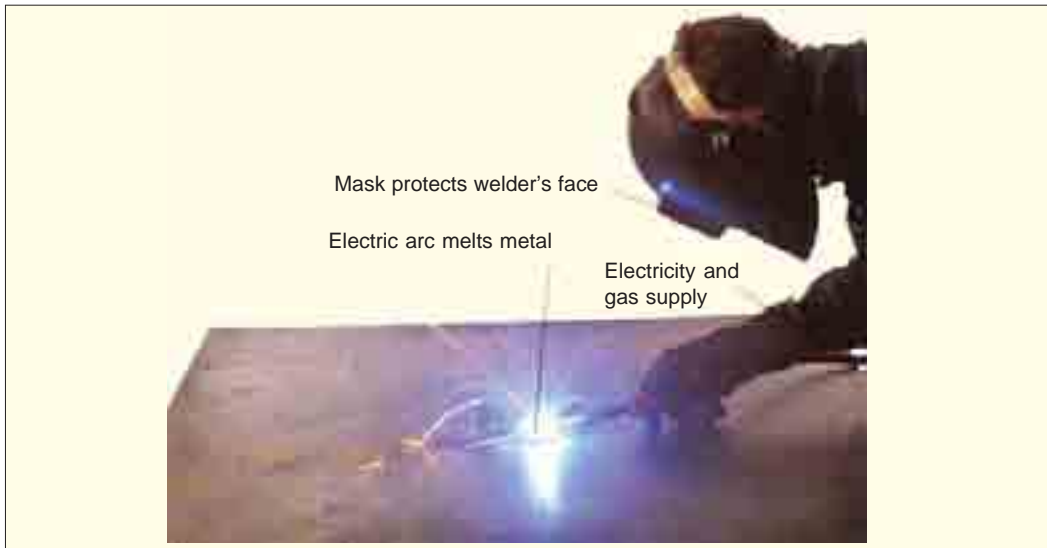

In TIG (Tungsten Inert Gas) and MIG (Metal Inert Gas) welding processes, the formation of oxide is prevented by shielding the metal with a blast of gas containing no oxygen.

10.21 Stress Concentration Factor for Welded Joints

The reinforcement provided to the weld produces stress concentration at the junction of the weld and the parent metal. When the parts are subjected to fatigue loading, the stress concentration factor as given in the following table should be taken into account.

Table 10.6. Stress concentration factor for welded joints.

Type of joint	Stress concentration factor
1. Reinforced butt welds	1.2
2. Toe of transverse fillet welds	1.5
3. End of parallel fillet weld	2.7
4. T-butt joint with sharp corner	2.0

Note : For static loading and any type of joint, stress concentration factor is 1.0.

Example 10.4. A plate 100 mm wide and 12.5 mm thick is to be welded to another plate by means of parallel fillet welds. The plates are subjected to a load of 50 kN. Find the length of the weld so that the maximum stress does not exceed 56 MPa. Consider the joint first under static loading and then under fatigue loading.

Solution. Given: *Width = 100 mm ; Thickness = 12.5 mm ; $P = 50 \text{ kN} = 50 \times 10^3 \text{ N}$; $\tau = 56 \text{ MPa} = 56 \text{ N/mm}^2$

Length of weld for static loading

Let l = Length of weld, and
 s = Size of weld = Plate thickness
 = 12.5 mm ... (Given)

We know that the maximum load which the plates can carry for double parallel fillet welds (P),

$$50 \times 10^3 = 1.414 s \times l \times \tau$$

$$= 1.414 \times 12.5 \times l \times 56 = 990 l$$

$$\therefore l = 50 \times 10^3 / 990 = 50.5 \text{ mm}$$

Adding 12.5 mm for starting and stopping of weld run, we have

$$l = 50.5 + 12.5 = 63 \text{ mm} \text{ Ans.}$$

Length of weld for fatigue loading

From Table 10.6, we find that the stress concentration factor for parallel fillet welding is 2.7.

\therefore Permissible shear stress,

$$\tau = 56 / 2.7 = 20.74 \text{ N/mm}^2$$

We know that the maximum load which the plates can carry for double parallel fillet welds (P),

$$50 \times 10^3 = 1.414 s \times l \times \tau = 1.414 \times 12.5 \times l \times 20.74 = 367 l$$

$$\therefore l = 50 \times 10^3 / 367 = 136.2 \text{ mm}$$

Adding 12.5 for starting and stopping of weld run, we have

$$l = 136.2 + 12.5 = 148.7 \text{ mm} \text{ Ans.}$$



TIG (Tungsten Inert Gas) welding Machine

Example 10.5. A plate 75 mm wide and 12.5 mm thick is joined with another plate by a single transverse weld and a double parallel fillet weld as shown in Fig. 10.15. The maximum tensile and shear stresses are 70 MPa and 56 MPa respectively.

Find the length of each parallel fillet weld, if the joint is subjected to both static and fatigue loading.

Solution. Given : Width = 75 mm ; Thickness = 12.5 mm ; $\sigma_t = 70 \text{ MPa} = 70 \text{ N/mm}^2$; $\tau = 56 \text{ MPa} = 56 \text{ N/mm}^2$.

The effective length of weld (l_1) for the transverse weld may be obtained by subtracting 12.5 mm from the width of the plate.

$$\therefore l_1 = 75 - 12.5 = 62.5 \text{ mm}$$

Length of each parallel fillet for static loading

Let l_2 = Length of each parallel fillet.

We know that the maximum load which the plate can carry is

$$P = \text{Area} \times \text{Stress} = 75 \times 12.5 \times 70 = 65\,625 \text{ N}$$

Load carried by single transverse weld,

$$P_1 = 0.707 s \times l_1 \times \sigma_t = 0.707 \times 12.5 \times 62.5 \times 70 = 38\,664 \text{ N}$$

and the load carried by double parallel fillet weld,

$$P_2 = 1.414 s \times l_2 \times \tau = 1.414 \times 12.5 \times l_2 \times 56 = 990 l_2 \text{ N}$$

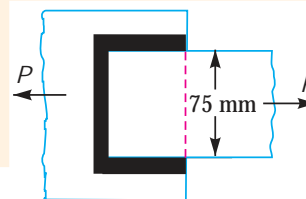

Fig. 10.15

* Superfluous data.

356 ■ A Textbook of Machine Design

∴ Load carried by the joint (P),

$$65\,625 = P_1 + P_2 = 38\,664 + 990 l_2 \quad \text{or} \quad l_2 = 27.2 \text{ mm}$$

Adding 12.5 mm for starting and stopping of weld run, we have

$$l_2 = 27.2 + 12.5 = 39.7 \text{ say } 40 \text{ mm} \quad \text{Ans.}$$

Length of each parallel fillet for fatigue loading

From Table 10.6, we find that the stress concentration factor for transverse welds is 1.5 and for parallel fillet welds is 2.7.

∴ Permissible tensile stress,

$$\sigma_t = 70 / 1.5 = 46.7 \text{ N/mm}^2$$

and permissible shear stress,

$$\tau = 56 / 2.7 = 20.74 \text{ N/mm}^2$$

Load carried by single transverse weld,

$$P_1 = 0.707 s \times l_1 \times \sigma_t = 0.707 \times 12.5 \times 62.5 \times 46.7 = 25\,795 \text{ N}$$

and load carried by double parallel fillet weld,

$$P_2 = 1.414 s \times l_2 \times \tau = 1.414 \times 12.5 l_2 \times 20.74 = 366 l_2 \text{ N}$$

∴ Load carried by the joint (P),

$$65\,625 = P_1 + P_2 = 25\,795 + 366 l_2 \quad \text{or} \quad l_2 = 108.8 \text{ mm}$$

Adding 12.5 mm for starting and stopping of weld run, we have

$$l_2 = 108.8 + 12.5 = 121.3 \text{ mm} \quad \text{Ans.}$$

Example 10.6. Determine the length of the weld run for a plate of size 120 mm wide and 15 mm thick to be welded to another plate by means of

1. A single transverse weld; and
2. Double parallel fillet welds when the joint is subjected to variable loads.

Solution. Given : Width = 120 mm ; Thickness = 15 mm

In Fig. 10.16, AB represents the single transverse weld and AC and BD represents double parallel fillet welds.

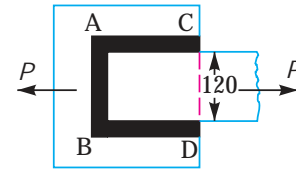

Fig. 10.16

1. Length of the weld run for a single transverse weld

The effective length of the weld run (l_1) for a single transverse weld may be obtained by subtracting 12.5 mm from the width of the plate.

$$\therefore l_1 = 120 - 12.5 = 107.5 \text{ mm} \quad \text{Ans.}$$

2. Length of the weld run for a double parallel fillet weld subjected to variable loads

Let l_2 = Length of weld run for each parallel fillet, and
 s = Size of weld = Thickness of plate = 15 mm

Assuming the tensile stress as 70 MPa or N/mm² and shear stress as 56 MPa or N/mm² for static loading. We know that the maximum load which the plate can carry is

$$P = \text{Area} \times \text{Stress} = 120 \times 15 \times 70 = 126 \times 10^3 \text{ N}$$

From Table 10.6, we find that the stress concentration factor for transverse weld is 1.5 and for parallel fillet welds is 2.7.

∴ Permissible tensile stress,

$$\sigma_t = 70 / 1.5 = 46.7 \text{ N/mm}^2$$

and permissible shear stress,

$$\tau = 56 / 2.7 = 20.74 \text{ N/mm}^2$$

∴ Load carried by single transverse weld,

$$P_1 = 0.707 s \times l_1 \times \sigma_t = 0.707 \times 15 \times 107.5 \times 46.7 = 53\,240 \text{ N}$$

and load carried by double parallel fillet weld,

$$P_2 = 1.414 s \times l_2 \times \tau = 1.414 \times 15 \times l_2 \times 20.74 = 440 l_2 \text{ N}$$

∴ Load carried by the joint (P),

$$126 \times 10^3 = P_1 + P_2 = 53\,240 + 440 l_2 \quad \text{or} \quad l_2 = 165.4 \text{ mm}$$

Adding 12.5 mm for starting and stopping of weld run, we have

$$l_2 = 165.4 + 12.5 = 177.9 \text{ say } 178 \text{ mm} \quad \text{Ans.}$$

Example 10.7. The fillet welds of equal legs are used to fabricate a 'T' as shown in Fig. 10.17 (a) and (b), where s is the leg size and l is the length of weld.

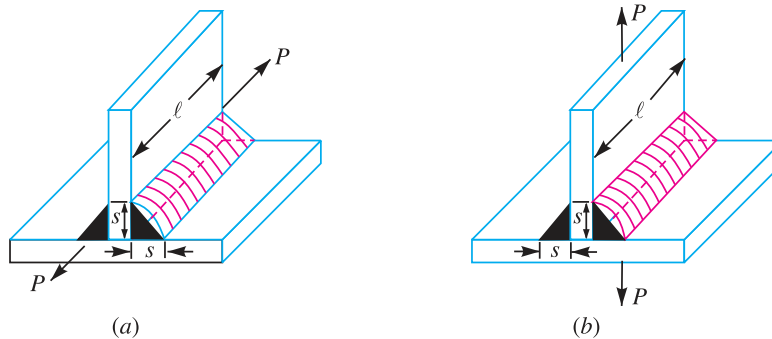

Fig. 10.17

Locate the plane of maximum shear stress in each of the following loading patterns:

1. Load parallel to the weld (neglect eccentricity), and
2. Load at right angles to the weld (transverse load).

Find the ratio of these limiting loads.

Solution. Given : Leg size = s ; Length of weld = l

1. Plane of maximum shear stress when load acts parallel to the weld (neglecting eccentricity)

Let θ = Angle of plane of maximum shear stress, and

t = Throat thickness BD .

From the geometry of Fig. 10.18, we find that

$$\begin{aligned} BC &= BE + EC \\ &= BE + DE \quad \dots(\because EC = DE) \end{aligned}$$

or

$$\begin{aligned} s &= BD \cos \theta + BD \sin \theta \\ &= t \cos \theta + t \sin \theta \\ &= t (\cos \theta + \sin \theta) \end{aligned}$$

$$\therefore t = \frac{s}{\cos \theta + \sin \theta}$$

We know that the minimum area of the weld or throat area,

$$A = 2 t \times l = \frac{2 s \times l}{(\cos \theta + \sin \theta)}$$

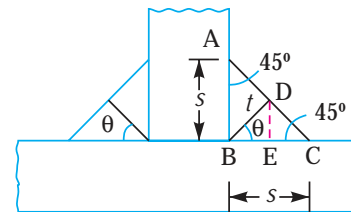

Fig. 10.18

∴ of double fillet weld)

358 ■ A Textbook of Machine Design

and shear stress,
$$\tau = \frac{P}{A} = \frac{P(\cos \theta + \sin \theta)}{2s \times l} \quad \dots(i)$$

For maximum shear stress, differentiate the above expression with respect to θ and equate to zero.

$$\therefore \frac{d\tau}{d\theta} = \frac{P}{2s \times l} (-\sin \theta + \cos \theta) = 0$$

or $\sin \theta = \cos \theta$ or $\theta = 45^\circ$

Substituting the value of $\theta = 45^\circ$ in equation (i), we have maximum shear stress,

$$\tau_{max} = \frac{P (\cos 45^\circ + \sin 45^\circ)}{2s \times l} = \frac{1.414 P}{2s \times l}$$

or
$$P = \frac{2s \times l \times \tau_{max}}{1.414} = 1.414 s \times l \times \tau_{max} \text{ Ans.}$$

2. Plane of maximum shear stress when load acts at right angles to the weld

When the load acts at right angles to the weld (transverse load), then the shear force and the normal force will act on each weld. Assuming that the two welds share the load equally, therefore summing up the vertical components, we have from Fig. 10.19,

$$\begin{aligned} P &= \frac{P_s}{2} \sin \theta + \frac{P_n}{2} \cos \theta + \frac{P_s}{2} \sin \theta + \frac{P_n}{2} \cos \theta \\ &= P_s \sin \theta + P_n \cos \theta \quad \dots(ii) \end{aligned}$$

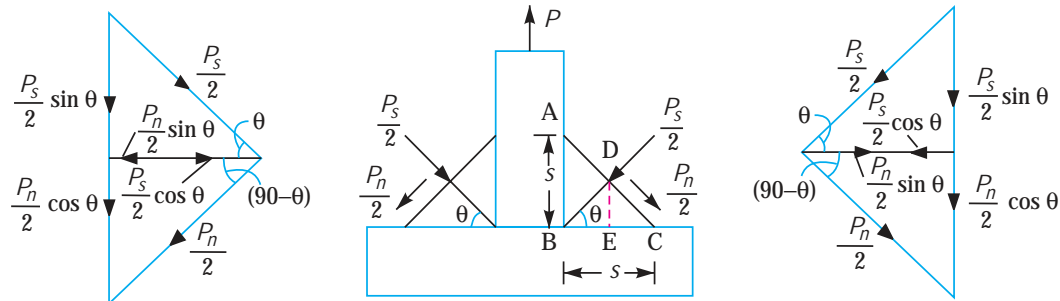

Fig. 10.19

Assuming that the resultant of $\frac{P_s}{2}$ and $\frac{P_n}{2}$ is vertical, then the horizontal components are equal and opposite. We know that

$$\text{Horizontal component of } \frac{P_s}{2} = \frac{P_s}{2} \cos \theta$$

and horizontal component of $\frac{P_n}{2} = \frac{P_n}{2} \sin \theta$

$$\therefore \frac{P_s}{2} \cos \theta = \frac{P_n}{2} \sin \theta \quad \text{or} \quad P_n = \frac{P_s \cos \theta}{\sin \theta}$$

Substituting the value of P_n in equation (ii), we have

$$P = P_s \sin \theta + \frac{P_s \cos \theta \times \cos \theta}{\sin \theta}$$

Multiplying throughout by $\sin \theta$, we have

$$\begin{aligned} P \sin \theta &= P_s \sin^2 \theta + P_s \cos^2 \theta \\ &= P_s (\sin^2 \theta + \cos^2 \theta) = P_s \quad \dots(ii) \end{aligned}$$

From the geometry of Fig. 10.19, we have

$$BC = BE + EC = BE + DE \quad \dots (\because EC = DE)$$

or $s = t \cos \theta + t \sin \theta = t (\cos \theta + \sin \theta)$

\therefore Throat thickness, $t = \frac{s}{\cos \theta + \sin \theta}$

and minimum area of the weld or throat area,

$$A = 2t \times l \quad \dots (\because \text{of double fillet weld})$$

$$= 2 \times \frac{s}{\cos \theta + \sin \theta} \times l = \frac{2s \times l}{\cos \theta + \sin \theta}$$

\therefore Shear stress, $\tau = \frac{P_s}{A} = \frac{P \sin \theta (\cos \theta + \sin \theta)}{2s \times l} \dots [\text{From equation (ii)}] \quad \dots (iii)$

For maximum shear stress, differentiate the above expression with respect to θ and equate to zero.

$$\therefore \frac{d\tau}{d\theta} = \frac{P}{2s \times l} [\sin \theta (-\sin \theta + \cos \theta) + (\cos \theta + \sin \theta) \cos \theta] = 0$$

$$\dots \left(\because \frac{d(u.v)}{d\theta} = u \frac{dv}{d\theta} + v \frac{du}{d\theta} \right)$$

or $-\sin^2 \theta + \sin \theta \cos \theta + \cos^2 \theta + \sin \theta \cos \theta = 0$
 $\cos^2 \theta - \sin^2 \theta + 2\sin \theta \cos \theta = 0$

Since $\cos^2 \theta - \sin^2 \theta = \cos 2\theta$ and $2 \sin \theta \cos \theta = \sin 2\theta$, therefore,
 $\cos 2\theta + \sin 2\theta = 0$

or $\frac{\sin 2\theta}{\cos 2\theta} = -1$ or $\tan 2\theta = -1$

$\therefore 2\theta = 135^\circ$ or $\theta = 67.5^\circ$ **Ans.**

Substituting the value of $\theta = 67.5^\circ$ in equation (iii), we have maximum shear stress,

$$\tau_{max} = \frac{P \sin 67.5^\circ (\cos 67.5^\circ + \sin 67.5^\circ)}{2s \times l}$$

$$= \frac{P \times 0.9239 (0.3827 + 0.9229)}{2s \times l} = \frac{1.21 P}{2s \times l}$$

and $P = \frac{2s \times l \times \tau_{max}}{1.21} = 1.65 s \times l \times \tau_{max}$ **Ans.**

Ratio of the limiting loads

We know that the ratio of the limiting (or maximum) loads

$$= \frac{1.414 s \times l \times \tau_{max}}{1.65 s \times l \times \tau_{max}} = 0.857 \quad \text{Ans.}$$

10.22 Axially Loaded Unsymmetrical Welded Sections

Sometimes unsymmetrical sections such as angles, channels, T-sections etc., welded on the flange edges are loaded axially as shown in Fig. 10.20. In such cases, the lengths of weld should be proportioned in such a way that the sum of resisting moments of the welds about the gravity axis is zero. Consider an angle section as shown in Fig. 10.20.



Plasma arc welding

- Let
- l_a = Length of weld at the top,
 - l_b = Length of weld at the bottom,
 - l = Total length of weld = $l_a + l_b$
 - P = Axial load,
 - a = Distance of top weld from gravity axis,
 - b = Distance of bottom weld from gravity axis, and
 - f = Resistance offered by the weld per unit length.

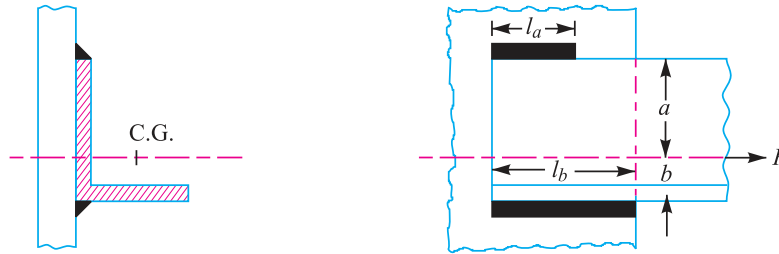

Fig. 10.20. Axially loaded unsymmetrical welded section.

∴ Moment of the top weld about gravity axis
 $= l_a \times f \times a$

and moment of the bottom weld about gravity axis
 $= l_b \times f \times b$

Since the sum of the moments of the weld about the gravity axis must be zero, therefore,

$$l_a \times f \times a - l_b \times f \times b = 0$$

or $l_a \times a = l_b \times b$...**(i)**

We know that $l = l_a + l_b$...**(ii)**

∴ From equations **(i)** and **(ii)**, we have

$$l_a = \frac{l \times b}{a + b}, \quad \text{and} \quad l_b = \frac{l \times a}{a + b}$$

Example 10.8. A $200 \times 150 \times 10$ mm angle is to be welded to a steel plate by fillet welds as shown in Fig. 10.21. If the angle is subjected to a static load of 200 kN, find the length of weld at the top and bottom. The allowable shear stress for static loading may be taken as 75 MPa.

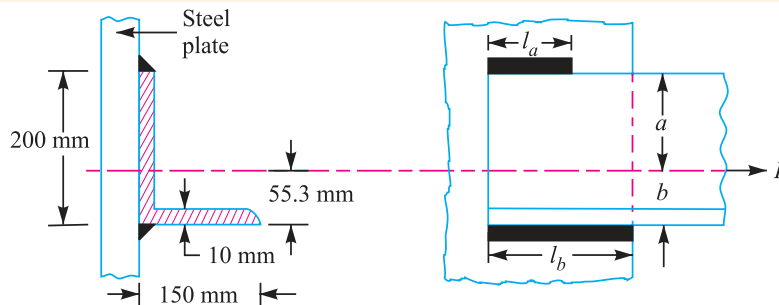

Fig. 10.21

Solution. Given : $a + b = 200$ mm ; $P = 200$ kN = 200×10^3 N ; $\tau = 75$ MPa = 75 N/mm²

- Let
- l_a = Length of weld at the top,
 - l_b = Length of weld at the bottom, and
 - l = Total length of the weld = $l_a + l_b$

Since the thickness of the angle is 10 mm, therefore size of weld,

$$s = 10 \text{ mm}$$

We know that for a single parallel fillet weld, the maximum load (P),

$$200 \times 10^3 = 0.707 s \times l \times \tau = 0.707 \times 10 \times l \times 75 = 530.25 l$$

$$\therefore l = 200 \times 10^3 / 530.25 = 377 \text{ mm}$$

or $l_a + l_b = 377 \text{ mm}$

Now let us find out the position of the centroidal axis.

Let b = Distance of centroidal axis from the bottom of the angle.

$$\therefore b = \frac{(200 - 10) 10 \times 95 + 150 \times 10 \times 5}{190 \times 10 + 150 \times 10} = 55.3 \text{ mm}$$

and $a = 200 - 55.3 = 144.7 \text{ mm}$

We know that $l_a = \frac{l \times b}{a + b} = \frac{377 \times 55.3}{200} = 104.2 \text{ mm}$ **Ans.**

and $l_b = l - l_a = 377 - 104.2 = 272.8 \text{ mm}$ **Ans.**

10.23 Eccentrically Loaded Welded Joints

An eccentric load may be imposed on welded joints in many ways. The stresses induced on the joint may be of different nature or of the same nature. The induced stresses are combined depending upon the nature of stresses. When the shear and bending stresses are simultaneously present in a joint (see case 1), then maximum stresses are as follows:

Maximum normal stress,

$$\sigma_{t(max)} = \frac{\sigma_b}{2} + \frac{1}{2} \sqrt{(\sigma_b)^2 + 4 \tau^2}$$

and maximum shear stress,

$$\tau_{max} = \frac{1}{2} \sqrt{(\sigma_b)^2 + 4 \tau^2}$$

where

σ_b = Bending stress, and

τ = Shear stress.

When the stresses are of the same nature, these may be combined vectorially (see case 2).

We shall now discuss the two cases of eccentric loading as follows:

Case 1

Consider a T-joint fixed at one end and subjected to an eccentric load P at a distance e as shown in Fig. 10.22.

Let s = Size of weld,
 l = Length of weld, and
 t = Throat thickness.

The joint will be subjected to the following two types of stresses:

1. Direct shear stress due to the shear force P acting at the welds, and
2. Bending stress due to the bending moment $P \times e$.

We know that area at the throat,

$$A = \text{Throat thickness} \times \text{Length of weld}$$

$$= t \times l \times 2 = 2 t \times l \quad \dots \text{(For double fillet weld)}$$

$$= 2 \times 0.707 s \times l = 1.414 s \times l \quad \dots (\because t = s \cos 45^\circ = 0.707 s)$$

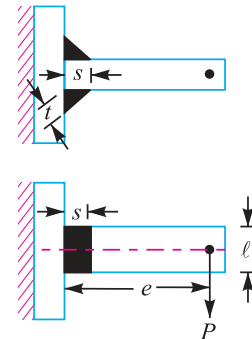

Fig. 10.22. Eccentrically loaded welded joint.

∴ Shear stress in the weld (assuming uniformly distributed),

$$\tau = \frac{P}{A} = \frac{P}{1.414 s \times l}$$

Section modulus of the weld metal through the throat,

$$Z = \frac{t \times l^2}{6} \times 2 \quad \dots(\text{For both sides weld})$$

$$= \frac{0.707 s \times l^2}{6} \times 2 = \frac{s \times l^2}{4.242}$$

Bending moment, $M = P \times e$

$$\therefore \text{Bending stress, } \sigma_b = \frac{M}{Z} = \frac{P \times e \times 4.242}{s \times l^2} = \frac{4.242 P \times e}{s \times l^2}$$

We know that the maximum normal stress,

$$\sigma_{t(max)} = \frac{1}{2} \sigma_b + \frac{1}{2} \sqrt{(\sigma_b)^2 + 4 \tau^2}$$

and maximum shear stress,

$$\tau_{max} = \frac{1}{2} \sqrt{(\sigma_b)^2 + 4 \tau^2}$$

Case 2

When a welded joint is loaded eccentrically as shown in Fig. 10.23, the following two types of the stresses are induced:

1. Direct or primary shear stress, and
2. Shear stress due to turning moment.

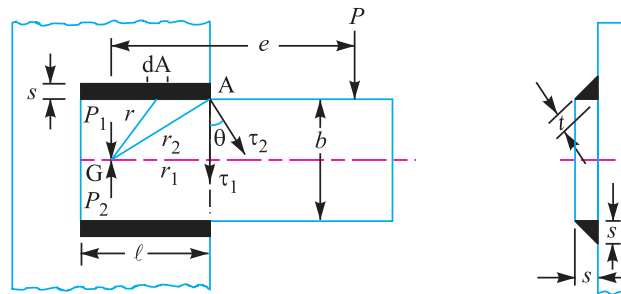

Fig. 10.23. Eccentrically loaded welded joint.

- Let
- P = Eccentric load,
 - e = Eccentricity *i.e.* perpendicular distance between the line of action of load and centre of gravity (G) of the throat section or fillets,
 - l = Length of single weld,
 - s = Size or leg of weld, and
 - t = Throat thickness.

Let two loads P_1 and P_2 (each equal to P) are introduced at the centre of gravity ' G ' of the weld system. The effect of load $P_1 = P$ is to produce direct shear stress which is assumed to be uniform over the entire weld length. The effect of load $P_2 = P$ is to produce a turning moment of magnitude $P \times e$ which tends of rotate the joint about the centre of gravity ' G ' of the weld system. Due to the turning moment, secondary shear stress is induced.



Soldering is done by melting a metal which melts at a lower temperature than the metal that is soldered.

We know that the direct or primary shear stress,

$$\begin{aligned}\tau_1 &= \frac{\text{Load}}{\text{Throat area}} = \frac{P}{A} = \frac{P}{2t \times l} \\ &= \frac{P}{2 \times 0.707s \times l} = \frac{P}{1.414s \times l}\end{aligned}$$

... (\because Throat area for single fillet weld = $t \times l = 0.707s \times l$)

Since the shear stress produced due to the turning moment ($T = P \times e$) at any section is proportional to its radial distance from G , therefore stress due to $P \times e$ at the point A is proportional to AG (r_2) and is in a direction at right angles to AG . In other words,

$$\frac{\tau_2}{r_2} = \frac{\tau}{r} = \text{Constant}$$

or
$$\tau = \frac{\tau_2}{r_2} \times r \quad \dots(i)$$

where τ_2 is the shear stress at the maximum distance (r_2) and τ is the shear stress at any distance r .

Consider a small section of the weld having area dA at a distance r from G .

\therefore Shear force on this small section

$$= \tau \times dA$$

and turning moment of this shear force about G ,

$$dT = \tau \times dA \times r = \frac{\tau_2}{r_2} \times dA \times r^2 \quad \dots \text{ [From equation (i)]}$$

\therefore Total turning moment over the whole weld area,

$$\begin{aligned}T &= P \times e = \int \frac{\tau_2}{r_2} \times dA \times r^2 = \frac{\tau_2}{r_2} \int dA \times r^2 \\ &= \frac{\tau_2}{r_2} \times J \quad \left(\because J = \int dA \times r^2 \right)\end{aligned}$$

where

J = Polar moment of inertia of the throat area about G .

\therefore Shear stress due to the turning moment *i.e.* secondary shear stress,

$$\tau_2 = \frac{T \times r_2}{J} = \frac{P \times e \times r_2}{J}$$

In order to find the resultant stress, the primary and secondary shear stresses are combined vectorially.

\therefore Resultant shear stress at A ,

$$\tau_A = \sqrt{(\tau_1)^2 + (\tau_2)^2 + 2\tau_1 \times \tau_2 \times \cos \theta}$$

where

θ = Angle between τ_1 and τ_2 , and

$$\cos \theta = r_1 / r_2$$

Note: The polar moment of inertia of the throat area (A) about the centre of gravity (G) is obtained by the parallel axis theorem, *i.e.*

$$J = 2 [I_{xx} + A \times x^2] \quad \dots (\because \text{ of double fillet weld})$$

$$= 2 \left[\frac{A \times l^2}{12} + A \times x^2 \right] = 2A \left(\frac{l^2}{12} + x^2 \right)$$

where

A = Throat area = $t \times l = 0.707s \times l$,

l = Length of weld, and

x = Perpendicular distance between the two parallel axes.

10.24 Polar Moment of Inertia and Section Modulus of Welds

The following table shows the values of polar moment of inertia of the throat area about the centre of gravity 'G' and section modulus for some important types of welds which may be used for eccentric loading.

Table 10.7. Polar moment of inertia and section modulus of welds.

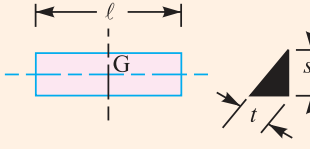
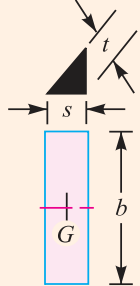
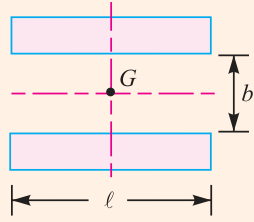
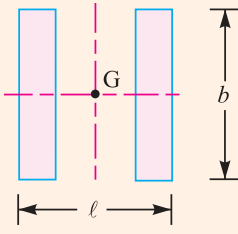
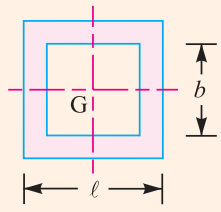
S.No	Type of weld	Polar moment of inertia (J)	Section modulus (Z)
1.		$\frac{t.l^3}{12}$	—
2.		$\frac{t.b^3}{12}$	$\frac{t.b^2}{6}$
3.		$\frac{t.l(3b^2 + l^2)}{6}$	$t.b.l$
4.		$\frac{t.b(b^2 + 3l^2)}{6}$	$\frac{t.b^2}{3}$
5.		$\frac{t(b+l)^3}{6}$	$t \left(b.l + \frac{b^2}{3} \right)$

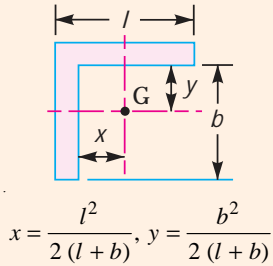
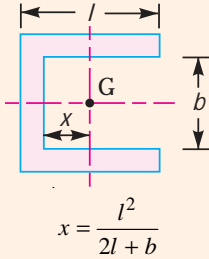
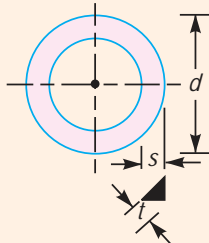
S.No	Type of weld	Polar moment of inertia (J)	Section modulus (Z)
6.	 $x = \frac{l^2}{2(l+b)}, y = \frac{b^2}{2(l+b)}$	$t \left[\frac{(b+l)^4 - 6b^2l^2}{12(l+b)} \right]$	$t \left(\frac{4lb + b^2}{6} \right)$ (Top) $t \left[\frac{b^2(4lb + b)}{6(2l + b)} \right]$ (Bottom)
7.	 $x = \frac{l^2}{2l + b}$	$t \left[\frac{(b+2l)^3}{12} - \frac{l^2(b+l)^2}{b+2l} \right]$	$t \left(lb + \frac{b^2}{6} \right)$
8.		$\frac{\pi t d^3}{4}$	$\frac{\pi t d^2}{4}$

Note: In the above expressions, t is the throat thickness and s is the size of weld. It has already been discussed that $t = 0.707 s$.

Example 10.9. A welded joint as shown in Fig. 10.24, is subjected to an eccentric load of 2 kN. Find the size of weld, if the maximum shear stress in the weld is 25 MPa.

Solution. Given: $P = 2\text{ kN} = 2000\text{ N}$; $e = 120\text{ mm}$; $l = 40\text{ mm}$; $\tau_{max} = 25\text{ MPa} = 25\text{ N/mm}^2$

Let $s =$ Size of weld in mm, and
 $t =$ Throat thickness.

The joint, as shown in Fig. 10.24, will be subjected to direct shear stress due to the shear force, $P = 2000\text{ N}$ and bending stress due to the bending moment of $P \times e$.

We know that area at the throat,

$$\begin{aligned} A &= 2t \times l = 2 \times 0.707 s \times l \\ &= 1.414 s \times l \\ &= 1.414 s \times 40 = 56.56 \times s \text{ mm}^2 \end{aligned}$$

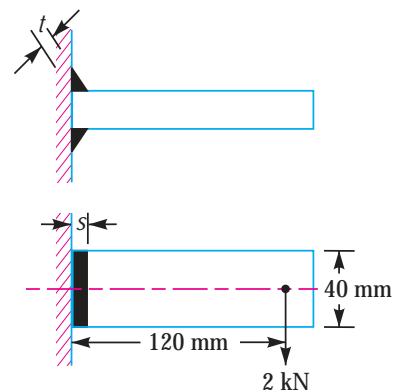

Fig. 10.24

$$\therefore \text{Shear stress, } \tau = \frac{P}{A} = \frac{2000}{56.56 \times s} = \frac{35.4}{s} \text{ N/mm}^2$$

$$\text{Bending moment, } M = P \times e = 2000 \times 120 = 240 \times 10^3 \text{ N-mm}$$

Section modulus of the weld through the throat,

$$Z = \frac{s \times l^2}{4.242} = \frac{s (40)^2}{4.242} = 377 \times s \text{ mm}^3$$

$$\therefore \text{Bending stress, } \sigma_b = \frac{M}{Z} = \frac{240 \times 10^3}{377 \times s} = \frac{636.6}{s} \text{ N/mm}^2$$

We know that maximum shear stress (τ_{max}),

$$25 = \frac{1}{2} \sqrt{(\sigma_b)^2 + 4 \tau^2} = \frac{1}{2} \sqrt{\left(\frac{636.6}{s}\right)^2 + 4 \left(\frac{35.4}{s}\right)^2} = \frac{320.3}{s}$$

$$\therefore s = 320.3 / 25 = 12.8 \text{ mm Ans.}$$

Example 10.10. A 50 mm diameter solid shaft is welded to a flat plate as shown in Fig. 10.25. If the size of the weld is 15 mm, find the maximum normal and shear stress in the weld.

Solution. Given : $D = 50 \text{ mm}$; $s = 15 \text{ mm}$; $P = 10 \text{ kN}$
 $= 10\,000 \text{ N}$; $e = 200 \text{ mm}$

Let $t =$ Throat thickness.

The joint, as shown in Fig. 10.25, is subjected to direct shear stress and the bending stress. We know that the throat area for a circular fillet weld,

$$\begin{aligned} A &= t \times \pi D = 0.707 s \times \pi D \\ &= 0.707 \times 15 \times \pi \times 50 \\ &= 1666 \text{ mm}^2 \end{aligned}$$

\therefore Direct shear stress,

$$\tau = \frac{P}{A} = \frac{10000}{1666} = 6 \text{ N/mm}^2 = 6 \text{ MPa}$$

We know that bending moment,

$$M = P \times e = 10\,000 \times 200 = 2 \times 10^6 \text{ N-mm}$$

From Table 10.7, we find that for a circular section, section modulus,

$$Z = \frac{\pi t D^2}{4} = \frac{\pi \times 0.707 s \times D^2}{4} = \frac{\pi \times 0.707 \times 15 (50)^2}{4} = 20\,825 \text{ mm}^3$$

\therefore Bending stress,

$$\sigma_b = \frac{M}{Z} = \frac{2 \times 10^6}{20\,825} = 96 \text{ N/mm}^2 = 96 \text{ MPa}$$

Maximum normal stress

We know that the maximum normal stress,

$$\begin{aligned} \sigma_{t(max)} &= \frac{1}{2} \sigma_b + \frac{1}{2} \sqrt{(\sigma_b)^2 + 4 \tau^2} = \frac{1}{2} \times 96 + \frac{1}{2} \sqrt{(96)^2 + 4 \times 6^2} \\ &= 48 + 48.4 = 96.4 \text{ MPa Ans.} \end{aligned}$$

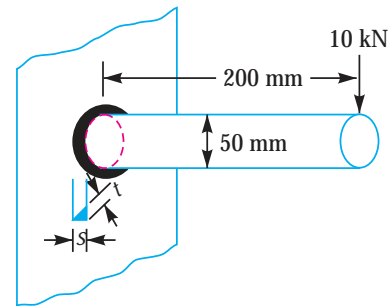

Fig. 10.25

Maximum shear stress

We know that the maximum shear stress,

$$\tau_{max} = \frac{1}{2} \sqrt{(\sigma_b)^2 + 4 \tau^2} = \frac{1}{2} \sqrt{(96)^2 + 4 \times 6^2} = 48.4 \text{ MPa} \quad \text{Ans.}$$

Example 10.11. A rectangular cross-section bar is welded to a support by means of fillet welds as shown in Fig. 10.26.

Determine the size of the welds, if the permissible shear stress in the weld is limited to 75 MPa.

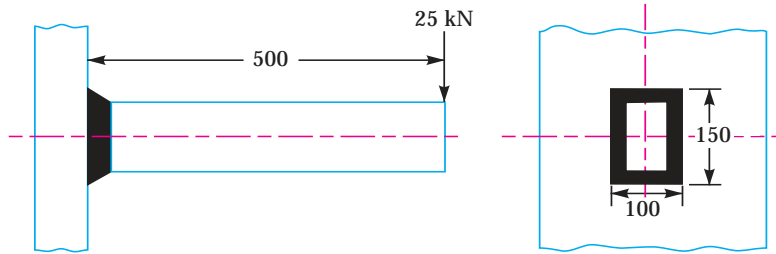

All dimensions in mm

Fig. 10.26

Solution. Given : $P = 25 \text{ kN} = 25 \times 10^3 \text{ N}$; $\tau_{max} = 75 \text{ MPa} = 75 \text{ N/mm}^2$; $l = 100 \text{ mm}$; $b = 150 \text{ mm}$; $e = 500 \text{ mm}$

Let $s =$ Size of the weld, and
 $t =$ Throat thickness.

The joint, as shown in Fig. 10.26, is subjected to direct shear stress and the bending stress. We know that the throat area for a rectangular fillet weld,

$$A = t(2b + 2l) = 0.707 s(2b + 2l) \\ = 0.707 s(2 \times 150 + 2 \times 100) = 353.5 s \text{ mm}^2 \quad \dots (\because t = 0.707s)$$

$$\therefore \text{Direct shear stress, } \tau = \frac{P}{A} = \frac{25 \times 10^3}{353.5 s} = \frac{70.72}{s} \text{ N/mm}^2$$

We know that bending moment,

$$M = P \times e = 25 \times 10^3 \times 500 = 12.5 \times 10^6 \text{ N-mm}$$

From Table 10.7, we find that for a rectangular section, section modulus,

$$Z = t \left(bl + \frac{b^2}{3} \right) = 0.707 s \left[150 \times 100 + \frac{(150)^2}{3} \right] = 15\,907.5 s \text{ mm}^3$$

$$\therefore \text{Bending stress, } \sigma_b = \frac{M}{Z} = \frac{12.5 \times 10^6}{15\,907.5 s} = \frac{785.8}{s} \text{ N/mm}^2$$

We know that maximum shear stress (τ_{max}),

$$75 = \frac{1}{2} \sqrt{(\sigma_b)^2 + 4 \tau^2} = \frac{1}{2} \sqrt{\left(\frac{785.8}{s}\right)^2 + 4 \left(\frac{70.72}{s}\right)^2} = \frac{399.2}{s}$$

$$\therefore s = 399.2 / 75 = 5.32 \text{ mm} \quad \text{Ans.}$$

Example 10.12. An arm A is welded to a hollow shaft at section '1'. The hollow shaft is welded to a plate C at section '2'. The arrangement is shown in Fig. 10.27, along with dimensions. A force $P = 15 \text{ kN}$ acts at arm A perpendicular to the axis of the arm.

Calculate the size of weld at section '1' and '2'. The permissible shear stress in the weld is 120 MPa.

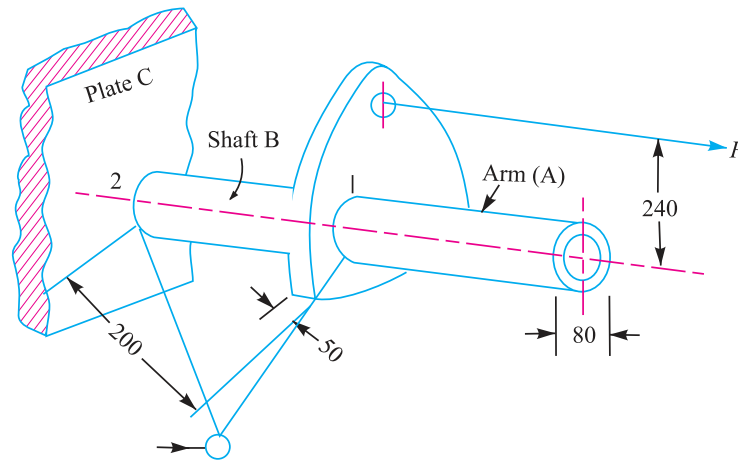

Fig. 10.27. All dimensions in mm.

Solution. Given : $P = 15 \text{ kN} = 15 \times 10^3 \text{ N}$; $\tau_{max} = 120 \text{ MPa} = 120 \text{ N/mm}^2$; $d = 80 \text{ mm}$
 Let $s =$ Size of the weld.

The welded joint, as shown in Fig. 10.27, is subjected to twisting moment or torque (T) as well as bending moment (M).

We know that the torque acting on the shaft,

$$T = 15 \times 10^3 \times 240 = 3600 \times 10^3 \text{ N-mm}$$

$$\therefore \text{Shear stress, } \tau = \frac{2.83 T}{\pi s d^2} = \frac{2.83 \times 3600 \times 10^3}{\pi \times s (80)^2} = \frac{506.6}{s} \text{ N/mm}^2$$

$$\text{Bending moment, } M = 15 \times 10^3 \left(200 - \frac{50}{2} \right) = 2625 \times 10^3 \text{ N-mm}$$

$$\therefore \text{Bending stress, } \sigma_b = \frac{5.66 M}{\pi s d^2} = \frac{5.66 \times 26.25 \times 10^3}{\pi s (80)^2} = \frac{738.8}{s} \text{ N/mm}^2$$

We know that maximum shear stress (τ_{max}),

$$120 = \frac{1}{2} \sqrt{(\sigma_b)^2 + 4 \tau^2} = \frac{1}{2} \sqrt{\left(\frac{738.8}{s} \right)^2 + 4 \left(\frac{506.6}{s} \right)^2} = \frac{627}{s}$$

$$\therefore s = 627/120 = 5.2 \text{ mm} \quad \text{Ans.}$$

Example 10.13. A bracket carrying a load of 15 kN is to be welded as shown in Fig. 10.28. Find the size of weld required if the allowable shear stress is not to exceed 80 MPa.

Solution. Given : $P = 15 \text{ kN} = 15 \times 10^3 \text{ N}$; $\tau = 80 \text{ MPa} = 80 \text{ N/mm}^2$; $b = 80 \text{ mm}$; $l = 50 \text{ mm}$; $e = 125 \text{ mm}$

Let $s =$ Size of weld in mm, and
 $t =$ Throat thickness.

We know that the throat area,

$$A = 2 \times t \times l = 2 \times 0.707 s \times l \\ = 1.414 s \times l = 1.414 \times s \times 50 = 70.7 s \text{ mm}^2$$

\therefore Direct or primary shear stress,

$$\tau_1 = \frac{P}{A} = \frac{15 \times 10^3}{70.7 s} = \frac{212}{s} \text{ N/mm}^2$$

From Table 10.7, we find that for such a section, the polar moment of inertia of the throat area of the weld about G is

$$J = \frac{t.l(3b^2 + l^2)}{6} = \frac{0.707 s \times 50 [3(80)^2 + (50)^2]}{6} \text{ mm}^4$$

$$= 127\,850 s \text{ mm}^4 \quad \dots (\because t = 0.707 s)$$

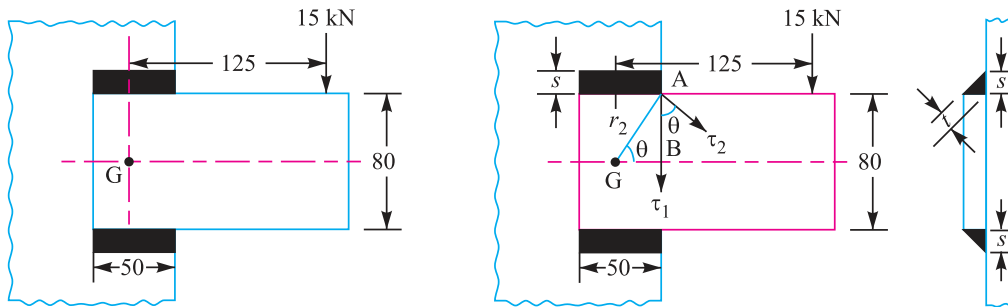

All dimensions in mm.

Fig. 10.28

Fig. 10.29

From Fig. 10.29, we find that $AB = 40 \text{ mm}$ and $BG = r_1 = 25 \text{ mm}$.

\therefore Maximum radius of the weld,

$$r_2 = \sqrt{(AB)^2 + (BG)^2} = \sqrt{(40)^2 + (25)^2} = 47 \text{ mm}$$

Shear stress due to the turning moment *i.e.* secondary shear stress,

$$\tau_2 = \frac{P \times e \times r_2}{J} = \frac{15 \times 10^3 \times 125 \times 47}{127\,850 s} = \frac{689.3}{s} \text{ N/mm}^2$$

and

$$\cos \theta = \frac{r_1}{r_2} = \frac{25}{47} = 0.532$$

We know that resultant shear stress,

$$\tau = \sqrt{(\tau_1)^2 + (\tau_2)^2 + 2 \tau_1 \times \tau_2 \cos \theta}$$

$$80 = \sqrt{\left(\frac{212}{s}\right)^2 + \left(\frac{689.3}{s}\right)^2 + 2 \times \frac{212}{s} \times \frac{689.3}{s} \times 0.532} = \frac{822}{s}$$

$$\therefore s = 822 / 80 = 10.3 \text{ mm} \quad \text{Ans.}$$

Example 10.14. A rectangular steel plate is welded as a cantilever to a vertical column and supports a single concentrated load P , as shown in Fig. 10.30.

Determine the weld size if shear stress in the same is not to exceed 140 MPa.

Solution. Given : $P = 60 \text{ kN} = 60 \times 10^3 \text{ N}$; $b = 100 \text{ mm}$; $l = 50 \text{ mm}$; $\tau = 140 \text{ MPa} = 140 \text{ N/mm}^2$

Let $s =$ Weld size, and

$t =$ Throat thickness.

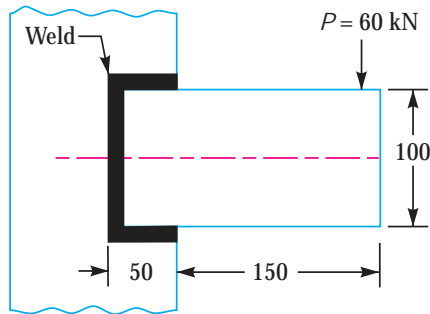

Fig. 10.30

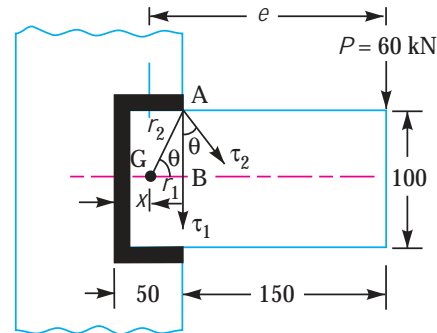

Fig. 10.31

All dimensions in mm.

First of all, let us find the centre of gravity (G) of the weld system, as shown in Fig. 10.31.

Let x be the distance of centre of gravity (G) from the left hand edge of the weld system. From Table 10.7, we find that for a section as shown in Fig. 10.31,

$$x = \frac{l^2}{2l + b} = \frac{(50)^2}{2 \times 50 + 100} = 12.5 \text{ mm}$$

and polar moment of inertia of the throat area of the weld system about G ,

$$\begin{aligned} J &= t \left[\frac{(b + 2l)^3}{12} - \frac{l^2 (b + l)^2}{b + 2l} \right] \\ &= 0.707s \left[\frac{(100 + 2 \times 50)^3}{12} - \frac{(50)^2 (100 + 50)^2}{100 + 2 \times 50} \right] \dots (\because t = 0.707s) \\ &= 0.707s [670 \times 10^3 - 281 \times 10^3] = 275 \times 10^3 s \text{ mm}^4 \end{aligned}$$

Distance of load from the centre of gravity (G) i.e. eccentricity,

$$e = 150 + 50 - 12.5 = 187.5 \text{ mm}$$

$$r_1 = BG = 50 - x = 50 - 12.5 = 37.5 \text{ mm}$$

$$AB = 100 / 2 = 50 \text{ mm}$$

We know that maximum radius of the weld,

$$r_2 = \sqrt{(AB)^2 + (BG)^2} = \sqrt{(50)^2 + (37.5)^2} = 62.5 \text{ mm}$$

$$\therefore \cos \theta = \frac{r_1}{r_2} = \frac{37.5}{62.5} = 0.6$$

We know that throat area of the weld system,

$$\begin{aligned} A &= 2 \times 0.707s \times l + 0.707s \times b = 0.707s (2l + b) \\ &= 0.707s (2 \times 50 + 100) = 141.4 s \text{ mm}^2 \end{aligned}$$

\therefore Direct or primary shear stress,

$$\tau_1 = \frac{P}{A} = \frac{60 \times 10^3}{141.4s} = \frac{424}{s} \text{ N/mm}^2$$

and shear stress due to the turning moment or secondary shear stress,

$$\tau_2 = \frac{P \times e \times r_2}{J} = \frac{60 \times 10^3 \times 187.5 \times 62.5}{275 \times 10^3 s} = \frac{2557}{s} \text{ N/mm}^2$$

We know that the resultant shear stress,

$$\tau = \sqrt{(\tau_1)^2 + (\tau_2)^2 + 2 \tau_1 \times \tau_2 \times \cos \theta}$$

$$140 = \sqrt{\left(\frac{424}{s}\right)^2 + \left(\frac{2557}{s}\right)^2 + 2 \times \frac{424}{s} \times \frac{2557}{s} \times 0.6} = \frac{2832}{s}$$

∴ $s = 2832 / 140 = 20.23 \text{ mm}$ **Ans.**

Example 10.15. Find the maximum shear stress induced in the weld of 6 mm size when a channel, as shown in Fig. 10.32, is welded to a plate and loaded with 20 kN force at a distance of 200 mm.

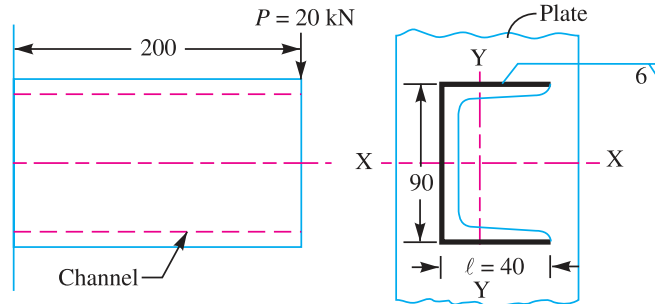

All dimensions in mm.

Fig. 10.32

Solution. Given : $s = 6 \text{ mm}$; $P = 20 \text{ kN} = 20 \times 10^3 \text{ N}$; $l = 40 \text{ mm}$; $b = 90 \text{ mm}$

Let $t =$ Throat thickness.

First of all, let us find the centre of gravity (G) of the weld system as shown in Fig. 10.33. Let x be the distance of centre of gravity from the left hand edge of the weld system. From Table 10.7, we find that for a section as shown in Fig. 10.33,

$$x = \frac{l^2}{2l + b} = \frac{(40)^2}{2 \times 40 + 90} = 9.4 \text{ mm}$$

and polar moment of inertia of the throat area of the weld system about G ,

$$J = t \left[\frac{(b + 2l)^3}{12} - \frac{l^2 (b + l)^2}{b + 2l} \right]$$

$$= 0.707 s \left[\frac{(90 + 2 \times 40)^3}{12} - \frac{(40)^2 (90 + 40)^2}{90 + 2 \times 40} \right] \dots (\because t = 0.707 s)$$

$$= 0.707 \times 6 [409.4 \times 10^3 - 159 \times 10^3] = 1062.2 \times 10^3 \text{ mm}^4$$

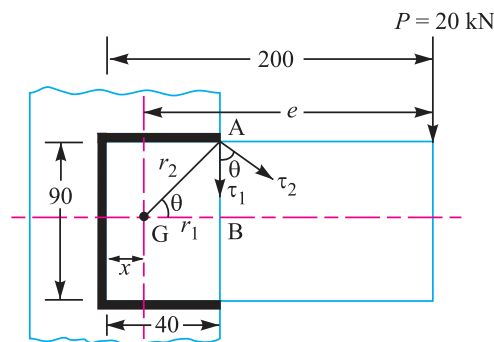

Fig. 10.33

372 ■ A Textbook of Machine Design

Distance of load from the centre of gravity (G), i.e. eccentricity,

$$e = 200 - x = 200 - 9.4 = 190.6 \text{ mm}$$

$$r_1 = BG = 40 - x = 40 - 9.4 = 30.6 \text{ mm}$$

$$AB = 90 / 2 = 45 \text{ mm}$$

We know that maximum radius of the weld,

$$r_2 = \sqrt{(AB)^2 + (BG)^2} = \sqrt{(45)^2 + (30.6)^2} = 54.4 \text{ mm}$$

$$\therefore \cos \theta = \frac{r_1}{r_2} = \frac{30.6}{54.4} = 0.5625$$

We know that throat area of the weld system,

$$A = 2 \times 0.707s \times l + 0.707s \times b = 0.707s(2l + b)$$

$$= 0.707 \times 6(2 \times 40 + 90) = 721.14 \text{ mm}^2$$

\therefore Direct or primary shear stress,

$$\tau_1 = \frac{P}{A} = \frac{20 \times 10^3}{721.14} = 27.7 \text{ N/mm}^2$$

and shear stress due to the turning moment or secondary shear stress,

$$\tau_2 = \frac{P \times e \times r_2}{J} = \frac{20 \times 10^3 \times 190.6 \times 54.4}{1062.2 \times 10^3} = 195.2 \text{ N/mm}^2$$

We know that resultant or maximum shear stress,

$$\tau = \sqrt{(\tau_1)^2 + (\tau_2)^2 + 2\tau_1 \times \tau_2 \times \cos \theta}$$

$$= \sqrt{(27.7)^2 + (195.2)^2 + 2 \times 27.7 \times 195.2 \times 0.5625}$$

$$= 212 \text{ N/mm}^2 = 212 \text{ MPa} \text{ Ans.}$$

Example 10.16. The bracket, as shown in Fig. 10.34, is designed to carry a dead weight of $P = 15 \text{ kN}$.

What sizes of the fillet welds are required at the top and bottom of the bracket? Assume the forces act through the points A and B. The welds are produced by shielded arc welding process with a permissible strength of 150 MPa.

Solution. Given : $P = 15 \text{ kN}$; $\tau = 150 \text{ MPa} = 150 \text{ N/mm}^2$; $l = 25 \text{ mm}$

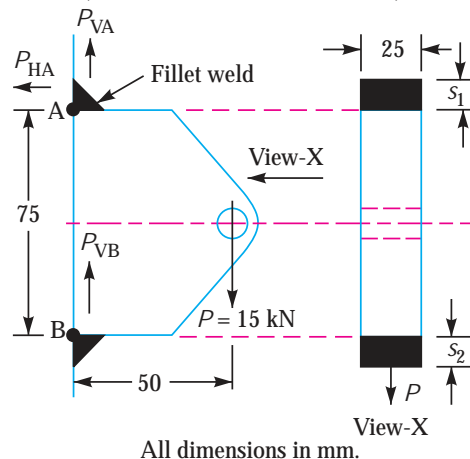

Fig. 10.34

In the joint, as shown in Fig. 10.34, the weld at A is subjected to a vertical force P_{VA} and a horizontal force P_{HA} , whereas the weld at B is subjected only to a vertical force P_{VB} . We know that

$$P_{VA} + P_{VB} = P \quad \text{and} \quad P_{VA} = P_{VB}$$

∴ Vertical force at A and B,

$$P_{VA} = P_{VB} = P / 2 = 15 / 2 = 7.5 \text{ kN} = 7500 \text{ N}$$

The horizontal force at A may be obtained by taking moments about point B.

$$\therefore P_{HA} \times 75 = 15 \times 50 = 750$$

or

$$P_{HA} = 750 / 75 = 10 \text{ kN}$$

Size of the fillet weld at the top of the bracket

Let s_1 = Size of the fillet weld at the top of the bracket in mm.

We know that the resultant force at A,

$$P_A = \sqrt{(P_{VA})^2 + (P_{HA})^2} = \sqrt{(7.5)^2 + (10)^2} = 12.5 \text{ kN} = 12\,500 \text{ N} \quad \dots(i)$$

We also know that the resultant force at A,

$$\begin{aligned} P_A &= \text{Throat area} \times \text{Permissible stress} \\ &= 0.707 s_1 \times l \times \tau = 0.707 s_1 \times 25 \times 150 = 2650 s_1 \quad \dots(ii) \end{aligned}$$

From equations (i) and (ii), we get

$$s_1 = 12\,500 / 2650 = 4.7 \text{ mm Ans.}$$

Size of fillet weld at the bottom of the bracket

Let s_2 = Size of the fillet weld at the bottom of the bracket.

The fillet weld at the bottom of the bracket is designed for the vertical force (P_{VB}) only. We know that

$$P_{VB} = 0.707 s_2 \times l \times \tau$$

$$7500 = 0.707 s_2 \times 25 \times 150 = 2650 s_2$$

$$\therefore s_2 = 7500 / 2650 = 2.83 \text{ mm Ans.}$$

EXERCISES

1. A plate 100 mm wide and 10 mm thick is to be welded with another plate by means of transverse welds at the ends. If the plates are subjected to a load of 70 kN, find the size of weld for static as well as fatigue load. The permissible tensile stress should not exceed 70 MPa. **[Ans. 83.2 mm; 118.5 mm]**
2. If the plates in Ex. 1, are joined by double parallel fillets and the shear stress is not to exceed 56 MPa, find the length of weld for (a) Static loading, and (b) Dynamic loading. **[Ans. 91 mm; 259 mm]**
3. A 125 × 95 × 10 mm angle is joined to a frame by two parallel fillet welds along the edges of 150 mm leg. The angle is subjected to a tensile load of 180 kN. Find the lengths of weld if the permissible static load per mm weld length is 430 N. **[Ans. 137 mm and 307 mm]**
4. A circular steel bar 50 mm diameter and 200 mm long is welded perpendicularly to a steel plate to form a cantilever to be loaded with 5 kN at the free end. Determine the size of the weld, assuming the allowable stress in the weld as 100 MPa. **[Ans. 7.2 mm]**

$$\left[\text{Hint : } \sigma_{b(max)} = \frac{5.66 M}{\pi s d^2} \right]$$

5. A 65 mm diameter solid shaft is to be welded to a flat plate by a fillet weld around the circumference of the shaft. Determine the size of the weld if the torque on the shaft is 3 kN-m. The allowable shear stress in the weld is 70 MPa. **[Ans. 10 mm]**

$$\left[\text{Hint : } \tau_{(max)} = \frac{2.83 T}{\pi s d^2} \right]$$

374 ■ A Textbook of Machine Design

6. A solid rectangular shaft of cross-section 80 mm × 50 mm is welded by a 5 mm fillet weld on all sides to a flat plate with axis perpendicular to the plate surface. Find the maximum torque that can be applied to the shaft, if the shear stress in the weld is not to exceed 85 MPa.

$$\left[\text{Hint : } \tau_{(max)} = \frac{4.242 T}{s \times l^2} \right]$$

[Ans. 32.07 kN-m]

7. A low carbon steel plate of 0.7 m width welded to a structure of similar material by means of two parallel fillet welds of 0.112 m length (each) is subjected to an eccentric load of 4000 N, the line of action of which has a distance of 1.5 m from the centre of gravity of the weld group. Design the required thickness of the plate when the allowable stress of the weld metal is 60 MPa and that of the plate is 40 MPa. [Ans. 2 mm]
8. A 125 × 95 × 10 mm angle is welded to a frame by two 10 mm fillet welds, as shown in Fig. 10.35. A load of 16 kN is applied normal to the gravity axis at a distance of 300 mm from the centre of gravity of welds. Find maximum shear stress in the welds, assuming each weld to be 100 mm long and parallel to the axis of the angle. [Ans. 45.5 MPa]

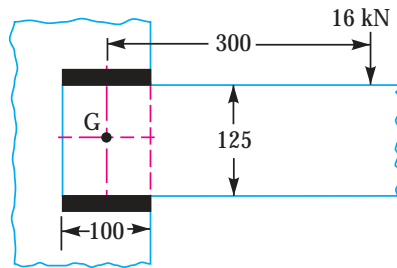

All dimensions in mm.

Fig. 10.35

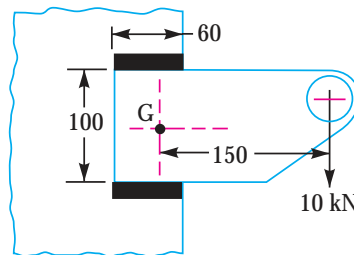

All dimensions in mm.

Fig. 10.36

9. A bracket, as shown in Fig. 10.36, carries a load of 10 kN. Find the size of the weld if the allowable shear stress is not to exceed 80 MPa. [Ans. 10.83 mm]

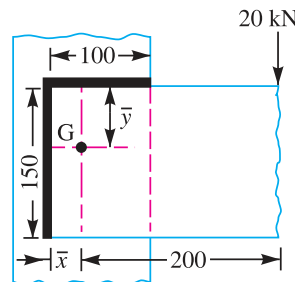

All dimensions in mm.

Fig. 10.37

10. Fig. 10.37 shows a welded joint subjected to an eccentric load of 20 kN. The welding is only on one side. Determine the uniform size of the weld on the entire length of two legs. Take permissible shear stress for the weld material as 80 MPa. [Ans. 8.9 mm]
11. A bracket is welded to the side of a column and carries a vertical load P , as shown in Fig. 10.38. Evaluate P so that the maximum shear stress in the 10 mm fillet welds is 80 MPa. [Ans. 50.7 kN]

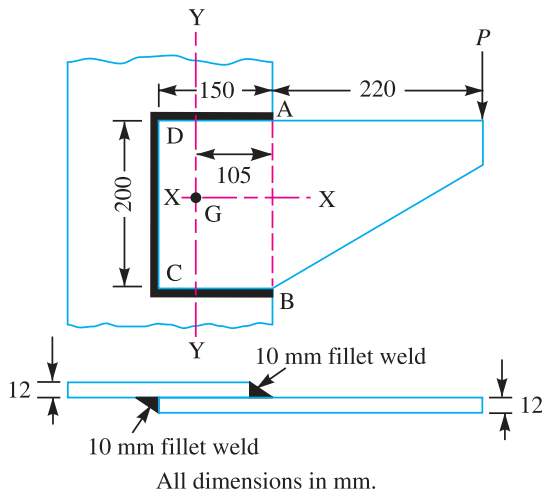

Fig. 10.38

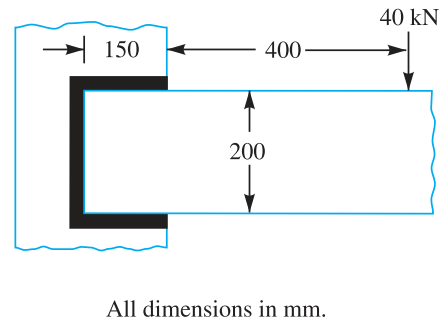

Fig. 10.39

12. A bracket, as shown in Fig. 10.39, carries a load of 40 kN. Calculate the size of weld, if the allowable shear stress is not to exceed 80 MPa. [Ans. 7 mm]

QUESTIONS

1. What do you understand by the term welded joint? How it differs from riveted joint?
2. Sketch and discuss the various types of welded joints used in pressure vessels. What are the considerations involved?
3. State the basic difference between manual welding, semi-automatic welding and automatic welding.
4. What are the assumptions made in the design of welded joint?
5. Explain joint preparation with particular reference to butt welding of plates by arc welding.
6. Discuss the standard location of elements of a welding symbol.
7. Explain the procedure for designing an axially loaded unsymmetrical welded section.
8. What is an eccentric loaded welded joint? Discuss the procedure for designing such a joint.
9. Show that the normal stress in case of an annular fillet weld subjected to bending is given by

$$\sigma = \frac{5.66 M}{\pi s d^2}$$

where M = Bending moment; s = Weld size and d = Diameter of cylindrical element welded to flat surface.

OBJECTIVE TYPE QUESTIONS

1. In a fusion welding process,

(a) only heat is used	(b) only pressure is used
(c) combination of heat and pressure is used	(d) none of these
2. The electric arc welding is a type of welding.

(a) forge	(b) fusion
-----------	------------
3. The principle of applying heat and pressure is widely used in

(a) spot welding	(b) seam welding
(c) projection welding	(d) all of these

376 ■ A Textbook of Machine Design

4. In transverse fillet welded joint, the size of weld is equal to
(a) $0.5 \times$ Throat of weld (b) Throat of weld
(c) $\sqrt{2} \times$ Throat of weld (d) $2 \times$ Throat of weld
5. The transverse fillet welded joints are designed for
(a) tensile strength (b) compressive strength
(c) bending strength (d) shear strength
6. The parallel fillet welded joint is designed for
(a) tensile strength (b) compressive strength
(c) bending strength (d) shear strength
7. The size of the weld in butt welded joint is equal to
(a) $0.5 \times$ Throat of weld (b) Throat of weld
(c) $\sqrt{2} \times$ Throat of weld (d) $2 \times$ Throat of weld
8. A double fillet welded joint with parallel fillet weld of length l and leg s is subjected to a tensile force P . Assuming uniform stress distribution, the shear stress in the weld is given by
(a) $\frac{\sqrt{2} P}{s.l}$ (b) $\frac{P}{2s.l}$
(c) $\frac{P}{\sqrt{2} s.l}$ (d) $\frac{2P}{s.l}$
9. When a circular rod welded to a rigid plate by a circular fillet weld is subjected to a twisting moment T , then the maximum shear stress is given by
(a) $\frac{2.83 T}{\pi s d^2}$ (b) $\frac{4.242 T}{\pi s d^2}$
(c) $\frac{5.66 T}{\pi s d^2}$ (d) none of these
10. For a parallel load on a fillet weld of equal legs, the plane of maximum shear occurs at
(a) 22.5° (b) 30°
(c) 45° (d) 60°

ANSWERS

1. (a) 2. (b) 3. (d) 4. (c) 5. (a)
6. (d) 7. (b) 8. (c) 9. (a) 10. (c)