

# 14

## *Hydraulic Turbines*

### 14.0 INTRODUCTION

Most of the electrical generators are powered by turbines. Turbines are the primemovers of civilisation. Steam and Gas turbines share in the electrical power generation is about 75%. About 20% of power is generated by hydraulic turbines and hence their importance. Rest of 5% only is by other means of generation. Hydraulic power depends on renewable source and hence is ever lasting. It is also non polluting in terms of non generation of carbon dioxide.

### 14.1 HYDRAULIC POWER PLANT

The main components of hydraulic power plant are (i) The storage system. (ii) Conveying system (iii) Hydraulic turbine with control system and (iv) Electrical generator

The storage system consists of a reservoir with a dam structure and the water flow control in terms of sluices and gates etc. The reservoir may be at a high level in the case of availability of such a location. In such cases the potential energy in the water will be large but the quantity of water available will be small. The conveying system may consist of tunnels, channels and steel pipes called penstocks. Tunnels and channels are used for surface conveyance. Penstocks are pressure pipes conveying the water from a higher level to a lower level under pressure. The penstock pipes end at the flow control system and are connected to nozzles at the end. The nozzles convert the potential energy to kinetic energy in free water jets. These jets by dynamic action turn the turbine wheels. In some cases the nozzles may be replaced by guide vanes which partially convert potential energy to kinetic energy and then direct the stream to the turbine wheel, where the remaining expansion takes place, causing a reaction on the turbine runner. Dams in river beds provide larger quantities of water but with a lower potential energy.

The reader is referred to books on power plants for details of the components and types of plants and their relative merits. In this chapter we shall concentrate on the details and operation of hydraulic turbines.

## 14.2 CLASSIFICATION OF TURBINES

The main classification depends upon the type of action of the water on the turbine. These are

(i) **Impulse turbine** (ii) **Reaction Turbine**. In the case of impulse turbine all the potential energy is converted to kinetic energy in the nozzles. The impulse provided by the jets is used to turn the turbine wheel. The pressure inside the turbine is atmospheric. This type is found suitable when the available potential energy is high and the flow available is comparatively low. Some people call this type as tangential flow units. Later discussion will show under what conditions this type is chosen for operation.

(ii) In reaction turbines the available potential energy is progressively converted in the turbines rotors and the reaction of the accelerating water causes the turning of the wheel. These are again divided into radial flow, mixed flow and axial flow machines. Radial flow machines are found suitable for moderate levels of potential energy and medium quantities of flow. The axial machines are suitable for low levels of potential energy and large flow rates. The potential energy available is generally denoted as “head available”. With this terminology plants are designated as “high head”, “medium head” and “low head” plants.

## 14.3 SIMILITUDE AND MODEL TESTING

Hydraulic turbines are mainly used for power generation and because of this these are large and heavy. The operating conditions in terms of available head and load fluctuation vary considerably. In spite of sophisticated design methodology, it is found the designs have to be validated by actual testing. In addition to the operation at the design conditions, the characteristics of operation under varying in put output conditions should be established. It is found almost impossible to test a full size unit under laboratory conditions. In case of variation of the operation from design conditions, large units cannot be modified or scrapped easily. The idea of similitude and model testing comes to the aid of the manufacturer.

In the case of these machines more than three variables affect the characteristics of the machine, (speed, flow rate, power, head available etc.). It is rather difficult to test each parameter's influence separately. It is also not easy to vary some of the parameters. Dimensional analysis comes to our aid, for solving this problem. In chapter 8 the important dimension less parameters in the case of turbomachines have been derived (problem 8.16).

The relevant parameters in the case of hydraulic machines have been identified in that chapter. These are

1. The head coefficient,  $gH/N^2D^2$  (14.3.1)

2. The flow coefficient,  $Q/ND^3$  (14.3.2)

3. The power coefficient,  $P/\rho N^3D^5$  (14.3.3)

4. The specific speed,  $N\sqrt{P}/\rho^{1/2}(gH)^{5/4}$  (14.3.4)

Consistent sets of units should be used to obtain numerical values. All the four dimensionless numbers are used in model testing. The last parameter has particular value when it comes to choosing a particular type under given available inputs and outputs. It has been established partly by experimentation and partly by analysis that the specific speed to some extent indicates the possible type of machine to provide the maximum efficiency under the given conditions. Figure 14.1 illustrates this idea. The representation is qualitative only. Note that as head decreases for the same power and speed, the specific speed increases.

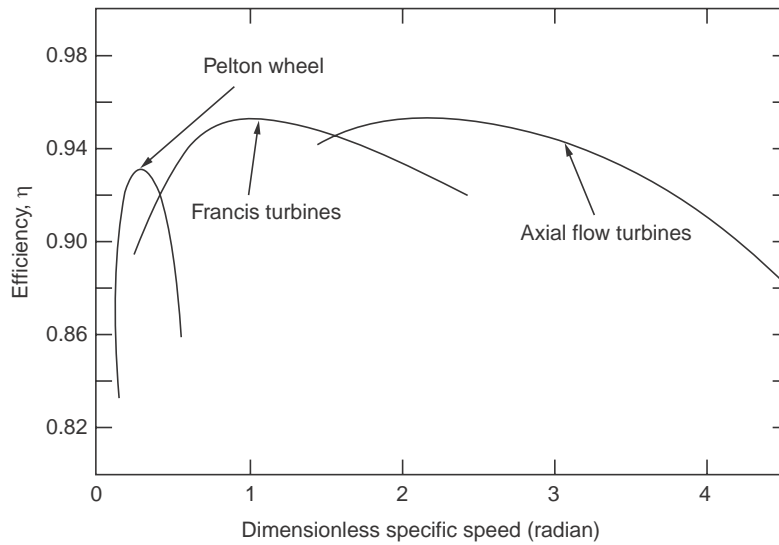

Figure 14.3.1 Variation of efficiency with specific speed.

Figure 14.3.2 gives another information provided by the specific speed. As flow rate increases for the same specific speed efficiency is found also to increase. For the same flow rate, there is an increase in efficiency with specific speed.

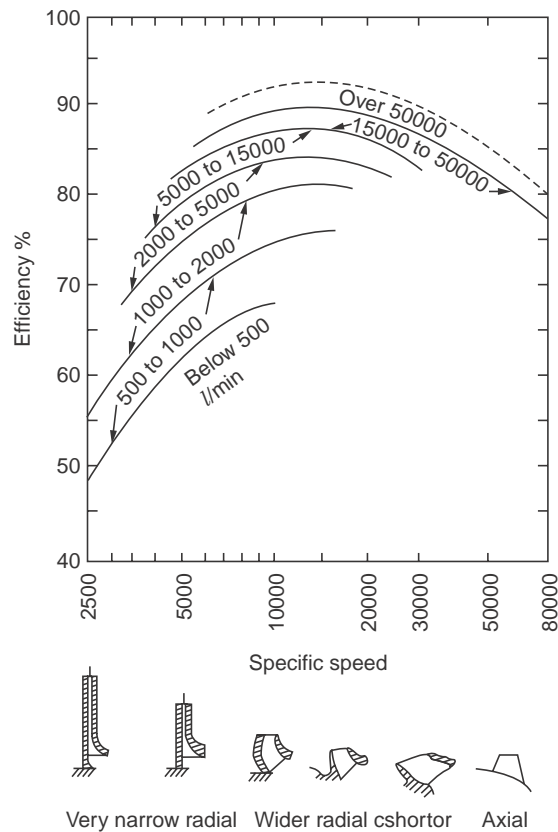

Figure 14.3.2 Variation of efficiency and flow passage with specific speed.

The type of flow passage also varies with specific speed as shown in the figure.

As the flow rate increases, the best shape is chosen for the maximum efficiency at that flow. The specific speed is obtained from the data available at the location where the plant is to be installed. Flow rate is estimated from hydrological data. Head is estimated from the topography.

Power is estimated by the product of head and flow rate. The speed is specified by the frequency of AC supply and the size. Lower the speed chosen, larger will be the size of the machine for the same power. These data lead to the calculation of the specific speed for the plant. The value of the specific speed gives a guidance about the choice of the type of machine. Worked examples will illustrate the idea more clearly.

The expressions given in the equation 14.3.1 to 4 are dimensionless and will give the same numerical value irrespective of the system of units adopted. In practice dimensional specific speed is popularly used

$$N_s = \frac{N \sqrt{P}}{H^{5/4}}$$

where  $N$  is in rps,  $P$  in  $W$  and  $H$  in  $m$ . This is also shown in Table 14.1.

Table 14.1 provides some guidance about the type of turbine suitable at various ranges of specific speeds.

**Table 14.1 Best specific Speed Range for Different Type of Hydraulic Turbines**

Dimensionless specific speed range	Dimensional specific speed in SI system	Type of turbine having the best efficiency at these values
0.015—0.053	8—29	Single jet Pelton turbine
0.047—0.072	26—40	Twin jet Pelton turbine
0.72—0.122	40—67	Multiple jet Pelton turbine
0.122—0.819	67—450	Radial flow turbine Francis type ( $H < 350m$ )
0.663—1.66	364—910	Axial flow Kaplan turbine. ( $H < 60m$ )

There is considerable variation in the specific speeds indicated by various authors. Speed  $N$  is used as rpm and power in kW by some authors.

Such use is dimensionly complex and will vary with values given in table 14.1. In the non dimensional form, speed should be in rps and power should be in  $W$ . Then only the value becomes dimensionless.

Consider the following

$$\frac{N \sqrt{P}}{\rho^{1/2} (gH)^{5/4}} \rightarrow \frac{1}{S} \frac{N^{1/2} m^{1/2}}{S^{1/2}} \cdot \frac{m^{3/2}}{kg^{1/2}} \cdot \frac{s^{10/4}}{m^{5/4}} \cdot m^{5/4}$$

Substituting for Newton  $N^{1/2}$  as  $kg^{1/2} m^{1/2}/s$  the expression will be dimensionless. This can be checked

$$N_s \rightarrow \frac{1}{s} \cdot \frac{kg^{1/2} m^{1/2} m^{1/2}}{s^{1/2} h^s} \cdot \frac{m^{1.5}}{kg^{1/2}} \cdot \frac{s^{2.5}}{m^{2.5}} \rightarrow M^\circ L^\circ T^\circ$$

$$\frac{1}{s} \cdot \frac{k^{1/2} m_1^{1/2}}{s} \cdot \frac{m^{1/2}}{s^{1/2}} \cdot \frac{m^{1.5} \cdot s^{2.5}}{kg^{1/2} m^{2.5}} \rightarrow M^\circ L^\circ T^\circ$$

As a check for the dimensional value listed, the omitted quantities in this case are  $\rho^{1/2} g^{1.2} = 549$

$$\therefore 0.015 \times 549 = 8.24 \text{ as in the tabulation.}$$

In the discussions the specific speed values in best efficiency is as given in table 14.1. But in the solved problems and examples, these conditions are generally not satisfied. Even with same actual installation data, the specific speed is found to vary from the listed best values for the type.

**Significance of specific speed.** Specific speed does not indicate the speed of the machine. It can be considered to indicate the flow area and shape of the runner. When the head is large, the velocity when potential energy is converted to kinetic energy will be high. The flow area required will be just the nozzle diameter. This cannot be arranged in a fully flowing type of turbine. Hence the best suited will be the impulse turbine. When the flow increases, still the area required will be unsuitable for a reaction turbine. So multi jet unit is chosen in such a case. As the head reduces and flow increases purely radial flow reaction turbines of smaller diameter can be chosen. As the head decreases still further and the flow increases, wider rotors with mixed flow are found suitable. The diameter can be reduced further and the speed increased up to the limit set by mechanical design. As the head drops further for the same power, the flow rate has to be higher. Hence axial flow units are found suitable in this situation. Keeping the power constant, the specific speed increases with  $N$  and decreases with head. The speed variation is not as high as the head variation. Hence specific speed value increases with the drop in available head. This can be easily seen from the values listed in table 14.1.

**Example 14.1.** Determine the specific speed for the data available at a location as given below (Both dimensionless and dimensional). Head available : 900 m.

Power estimated 40000 kW, Speed required : 417.5 rpm. Also indicate the suitable type of turbine

**Dimensionless** specific speed : units to be used :

$$N \rightarrow \text{rps}, P \rightarrow W \text{ or } Nm/s, \rho \rightarrow \text{kg/m}^3, g \rightarrow \frac{\text{m}}{\text{s}^2}, H \rightarrow \text{m}$$

$$\therefore N_s = \frac{417.5}{60} \times \frac{(40,000,000)^{1/2}}{1000^{1/2} \times 9.81^{5/4} \times 900^{5/4}} = \mathbf{0.0163.}$$

Hence single jet pelton turbine is suitable.

**Non dimensional** specific speed.

$$N_s = \frac{417.5}{60} \times \frac{40,000,000^{1/2}}{900^{5/4}} = \mathbf{8.92.}$$

Agrees with the former value.

Single jet impulse turbine will be suitable.

**Example 14.2.** At a location the head available was estimated as 200 m. The power potential was 50,000 kW. The speed chosen is 600 rpm. **Determine the specific speed.** Indicate what type of turbine is suitable.

**Dimensionless.**  $N \rightarrow rps, P \rightarrow W, g \rightarrow \frac{m^3}{kg}, g \rightarrow \frac{m}{s^2}, H \rightarrow m$

$$N_s = \frac{600 \sqrt{40,000,000}}{60 \times (200 \times 9.81)^{5/4} \times 1000^{1/2}} = \mathbf{0.153.}$$

Hence **Francis type of turbine is suitable.**

**Dimensional.**  $N_s = \frac{600}{60} \times \frac{(40,000,000)^{1/2}}{200^{5/4}} = \mathbf{84.09.}$

Hence **agrees with the previous value.**

**Example 14.3.** At a location, the head available was 50 m. The power estimated is 40,000 kW. The speed chosen is 600 rpm. **Determine the specific speed and indicate the suitable type of turbine.**

**Dimensionless**  $N_s = \frac{600}{60} \cdot \frac{\sqrt{40,000,000}}{1000^{1/2} (9.81 \times 50)^{5/4}} = \mathbf{0.866}$

Hence **axial flow Kaplan turbine** is suitable.

**Dimensional**  $N_s = \frac{600}{60} \times \frac{40,000,000^{1/2}}{50^{1.25}} = \mathbf{475.}$

### 14.3.1 Model and Prototype

It is found not desirable to rely completely on design calculations before manufacturing a large turbine unit. It is necessary to obtain test results which will indicate the performance of the large unit. This is done by testing a “homologous” or similar model of smaller size and predicting from the results the performance of large unit. Similarity conditions are three fold namely geometric similarity, kinematic similarity and dynamic similarity. Equal ratios of geometric dimensions leads to geometric similarity.

Similar flow pattern leads to kinematic similarity. Similar dynamic conditions in terms of velocity, acceleration, forces etc. leads to dynamic similarity. A model satisfying these conditions is called “Homologous” model. In such case, it can be shown that specific speeds, head coefficients flow coefficient and power coefficient will be identical between the model and the **large machine called prototype**. It is also possible from these experiments to predict part load performance and operation at different head speed and flow conditions.

The **ratio between linear dimensions is called scale**. For example an one eighth scale model means that the linear dimensions of the model is 1/8 of the linear dimensions of the larger machine or the prototype. For kinematic and dynamic similarity the flow directions and the blade angles should be equal.

**Example 14.4.** At a location investigations yielded the following data for the installation of a hydro plant. Head available = 200 m, power available = 40,000 kW. The speed chosen was 500 rpm. A model study was proposed. In the laboratory head available was 20 m. It was proposed to construct a 1/6 scale model. **Determine the speed and dynamo meter capacity to test the model. Also determine the flow rate required in terms of the prototype flow rate.**

The dimensional specific speed of the proposed turbine

$$N_s = \frac{N\sqrt{P}}{H^{5/4}} = \frac{500 \sqrt{40,000,000}}{200^{5/4}} = 70.0747$$

The specific speed of the model should be the same. As two unknowns are involved another parameter has to be used to solve the problem.

Choosing head coefficient, (as both heads are known)

$$\frac{H_m}{N_m^2 D_m^2} = \frac{H_p}{N_p^2 D_p^2} \quad \therefore N_m^2 = \frac{H_m}{H_p} \cdot N_p^2 \left(\frac{D_p}{D_m}\right)^2$$

$$\therefore N_m = \left[ \frac{20}{200} \times 500^2 (6^2) \right]^{0.5} = 948.7 \text{ rpm}$$

Substituting in the specific speed expression,

$$70.0747 = \frac{984.7 \sqrt{P_m}}{60 \times 20^{5/4}}$$

Solving

$$P_m = 35062 \text{ W} = \mathbf{35.062 \text{ kW}}$$

$\therefore$  The model is to have a capacity of 35.062 kW and run at 948.7 rpm.

The flow rate ratio can be obtained using flow coefficient

$$\frac{Q_m}{N_m D_m^3} = \frac{Q_p}{N_p D_p^3}$$

$$\therefore \frac{Q_m}{Q_p} = \frac{N_m D_m^3}{N_p D_p^3} = \frac{948.7}{500} \times \frac{1}{6^3} = 0.08777$$

or  $Q_m$  is  $\frac{1}{113}$  of  $Q_p$ .

**Example 14.5.** In example 14.4, the data in the proposed plant is given. These are 200 m, head, 40000 kW power and 500 rpm.

A one sixth scale model is proposed. The test facility has a limited dynamometer capacity of 40 kW only whereas the speed and head have no limitations. Determine the speed and head required for the model.

The value of dimensional specific speed of the proposed plant is taken from example 14.4 as 70.0747.

In this case it is preferable to choose the power coefficient

$$\frac{P_m}{N_m^3 D_m^5} = \frac{P_p}{N_p^3 D_p^5} \quad \therefore N_m^3 = \frac{P_m}{P_p} \times N_p^3 \times \left(\frac{D_p}{D_m}\right)^5$$

$$\therefore N_m = \left[ \frac{40}{40,000} \times 500^3 \times 6^5 \right]^{1/3} = \mathbf{990.6 \text{ rpm}}$$

Using the specific speed value (for the model)

$$70.0747 = \frac{990.6}{60} \times \frac{\sqrt{40,000}}{H_m^{5/4}} \quad \text{or} \quad H_m^{5/4} = \frac{990.6\sqrt{40,000}}{60 \times 70.0747}$$

Solving  $H_m = 21.8$  m. Test head required is 21.8 m and test speed is 990.6 rpm.

The flow rate can be obtained using the flow coefficient

$$\frac{Q_m}{Q_p} = \frac{N_m D_m^3}{N_p D_p^3} = \frac{990.6}{500} \times \frac{1}{6^3} = 0.0916 \quad \text{or} \quad \frac{1}{109.9} \quad \text{times the flow in prototype.}$$

**Example 14.6.** Use the data for the proposed hydro plant given in example 14.4. The test facility has only a constant speed dynamometer running at 1000 rpm. In this case determine power of the model and the test head required.

The specific speed of the proposed plant is 70.0747 and the models should have the same value of specific speed.

In this case the head coefficient is more convenient for solving the problem.

$$H_m = H_p \frac{N_m^2}{N_p^2} \cdot \left(\frac{D_m}{D_p}\right)^2 = 200 \times \left(\frac{1000}{500}\right)^2 \left(\frac{1}{6}\right)^2 = 22.22 \text{ m}$$

Substituting in the specific speed expression,

$$70.0747 = \frac{1000 \sqrt{P}}{60 \times 22.22^{5/4}}.$$

Solving  $P = 41146$  W or **40.146 kW**

The flow ratio

$$\frac{Q_m}{Q_p} = \frac{N_m}{N_p} \cdot \frac{D_m^3}{D_p^3} = \frac{1000}{500} \times \frac{1}{6^3} = 0.00926$$

or  $\frac{1}{108}$  times the prototype flow.

### 14.3.2 Unit Quantities

The dimensionless constants can also be used to predict the performance of a given machine under different operating conditions. As the linear dimension will be the same, the same will not be taken into account in the calculation. Thus

Head coefficient will now be

$$\frac{H_1}{N_1^2 D^2} = \frac{H_2}{N_2^2 D^2} \quad \text{or} \quad \frac{H_2}{H_1} = \frac{N_2^2}{N_1^2}$$

**The head will vary as the square of the speed.**

The flow coefficient will lead to

$$\frac{Q_1}{N_1 D^3} = \frac{Q_2}{N_2 D^3} \quad \text{or} \quad \frac{Q_2}{Q_1} = \frac{N_2}{N_1}$$



**Flow will be proportional to N and** using the previous relation

$$\frac{Q_2}{Q_1} = \sqrt{\frac{H_2}{H_1}} \quad \text{or} \quad \frac{Q}{\sqrt{H}} = \text{constant for a machine.}$$

**The constant is called unit discharge.**

Similarly 
$$\frac{N_2}{N_1} = \sqrt{\frac{H_2}{H_1}} \quad \text{or} \quad \frac{N}{\sqrt{H}} = \text{constant.}$$

**This constant is called unit speed.**

Using the power coefficient :

$$\frac{P_1}{N^3 D^5} = \frac{P_2}{N^3 D^5} \quad \text{or} \quad \frac{P_2}{P_1} = \frac{N_2^3}{N_1^3} = \left(\frac{H_2}{H_1}\right)^{3/2}$$

or 
$$\frac{P}{H^{3/2}} = \text{constant.}$$
 This constant is called **unit power**.

Hence when  $H$  is varied in a machine the other quantities can be predicted by the use of unit quantities.

**Example 14.7.** A turbine is operating with a head of 400 m and speed of 500 rpm and flow rate of  $5 \text{ m}^3/\text{s}$  producing the power of 17.66 MW. The head available changed to 350 m. If no other corrective action was taken what would be the speed, flow and power? Assume efficiency is maintained.

1. 
$$\frac{H_1}{N_1^2} = \frac{H_2}{N_2^2}$$

$$\therefore \frac{N_2}{N_1} = \left[\frac{350}{400}\right]^{0.5} = 0.93541 \quad \text{or} \quad N_2 = 500 \times 0.93541 = \mathbf{467.7 \text{ rpm}}$$

2. 
$$\frac{Q_1}{N_1} = \frac{Q_2}{N_2} \quad \text{or} \quad \frac{Q_2}{Q_1} = \frac{N_2}{N_1} = \sqrt{\frac{H_2}{H_1}} = \left(\frac{350}{400}\right)^{0.5}$$

$$\therefore Q_2 = 5 \times 0.93531 = \mathbf{4.677 \text{ m}^3/\text{s}}$$

3. 
$$\frac{P_2}{P_1} = \left(\frac{H_2}{H_1}\right)^{3/2} \quad \therefore P_2 = 17.66 \times \left(\frac{350}{400}\right)^{0.5} = \mathbf{14.45 \text{ MW}}$$

## 14.4 TURBINE EFFICIENCIES

The head available for hydroelectric plant depends on the site conditions. Gross head is defined as the difference in level between the reservoir water level (called head race) and the level of water in the stream into which the water is let out (called tail race), both levels to be observed at the same time. During the conveyance of water there are losses involved. The difference between the gross head and head loss is called the net head or effective head. It can be measured

by the difference in pressure between the turbine entry and tailrace level. The following efficiencies are generally used.

**1. Hydraulic efficiency :** It is defined as the ratio of the power produced by the turbine runner and the power supplied by the water at the turbine inlet.

$$\eta_H = \frac{\text{Power produced by the runner}}{\rho Q g H} \quad (14.4.1)$$

where  $Q$  is the volume flow rate and  $H$  is the net or effective head. Power produced by the runner is calculated by the Euler turbine equation  $P = Q\rho [u_1 V_{u1} - u_2 V_{u2}]$ . This reflects the runner design effectiveness.

**2. Volumetric efficiency :** It is possible some water flows out through the clearance between the runner and casing without passing through the runner.

Volumetric efficiency is defined as the ratio between the volume of water flowing through the runner and the total volume of water supplied to the turbine. Indicating  $Q$  as the volume flow and  $\Delta Q$  as the volume of water passing out without flowing through the runner.

$$\eta_v = \frac{Q - \Delta Q}{Q} \quad (14.4.2)$$

To some extent this depends on manufacturing tolerances.

**3. Mechanical efficiency :** The power produced by the runner is always greater than the power available at the turbine shaft. This is due to mechanical losses at the bearings, windage losses and other frictional losses.

$$\eta_m = \frac{\text{Power available at the turbine shaft}}{\text{Power produced by the runner}} \quad (14.4.3)$$

**4. Overall efficiency :** This is the ratio of power output at the shaft and power input by the water at the turbine inlet.

$$\eta_0 = \frac{\text{Power available at the turbine shaft}}{\rho Q g H} \quad (14.4.4)$$

Also the overall efficiency is the product of the other three efficiencies defined

$$\eta_0 = N_H N_m N_v \quad (14.4.5)$$

## 14.5 EULER TURBINE EQUATION

The fluid velocity at the turbine entry and exit can have three components in the tangential, axial and radial directions of the rotor. This means that the fluid momentum can have three components at the entry and exit. This also means that the force exerted on the runner can have three components. **Out of these the tangential force only can cause the rotation of the runner and produce work.** The axial component produces a thrust in the axial direction, which is taken by suitable thrust bearings. The radial component produces a bending of the shaft which is taken by the journal bearings.

Thus it is necessary to consider the tangential component for the determination of work done and power produced. The work done or power produced by the tangential force equals the product of the mass flow, tangential force and the tangential velocity. As the tangential velocity varies with the radius, the work done also will vary with the radius. It is not easy to sum up this work. The help of moment of momentum theorem is used for this purpose. It states that **the torque on the rotor equals the rate of change of moment of momentum of the fluid as it passes through the runner.**

Let  $u_1$  be the tangential velocity at entry and  $u_2$  be the tangential velocity at exit.

Let  $V_{u1}$  be the tangential component of the absolute velocity of the fluid at inlet and let  $V_{u2}$  be the tangential component of the absolute velocity of the fluid at exit. Let  $r_1$  and  $r_2$  be the radii at inlet and exit.

The tangential momentum of the fluid at inlet =  $\dot{m} V_{u1}$

The tangential momentum of the fluid at exit =  $\dot{m} V_{u2}$

The moment of momentum at inlet =  $\dot{m} V_{u1} r_1$

The moment of momentum at exit =  $\dot{m} V_{u2} r_2$

$$\therefore \text{Torque, } \tau = \dot{m}(V_{u1} r_1 - V_{u2} r_2) \quad (14.5.1)$$

Depending on the direction of  $V_{u2}$  with reference to  $V_{u1}$ , the  $-$  sign will become  $+$  ve sign.

$$\text{Power} = \omega\tau \text{ and } \omega = \frac{2\pi N}{60} \quad (14.5.2)$$

where  $N$  is rpm.

$$\therefore \text{Power} = \dot{m} \frac{2\pi N}{60} (V_{u1} r_1 - V_{u2} r_2) \quad (14.5.3)$$

$$\text{But } \frac{2\pi N}{60} r_1 = u_1 \text{ and } \frac{2\pi N}{60} r_2 = u_2$$

$$\therefore \text{Power} = \dot{m} (V_{u1} u_1 - V_{u2} u_2) \quad (14.5.4)$$

**Equation (14.5.4) is known as Euler Turbine equation.**

### 14.5.1 Components of Power Produced

The power produced can be expressed as due to three effects. These are the **dynamic, centrifugal and acceleration effects**. Consider the general velocity triangles at inlet and exit of turbine runner, shown in figure 14.5.1.

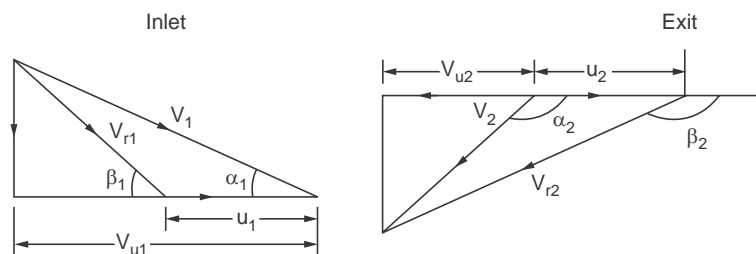

Figure 14.5.1 Velocity triangles

$V_1, V_2$  Absolute velocities at inlet and outlet.

$V_{r1}, V_{r2}$  Relative velocities at inlet and outlet.

$u_1, u_2$  Tangential velocities at inlet and outlet.

$V_{u1}, V_{u2}$  Tangential component of absolute velocities at inlet and outlet.

From inlet velocity triangle, ( $V_{u1} = V_1 \cos \alpha_1$ )

$$V_{r1}^2 = V_1^2 + u_1^2 - 2u_1 V_1 \cos \alpha_1$$

$$\text{or} \quad u_1 V_1 \cos \alpha_1 = V_{u1} u_1 = \frac{V_1^2 + u_1^2 - V_{r1}^2}{2} \quad (\text{A})$$

From outlet velocity triangle ( $V_{u2} = V_2 \cos \alpha_2$ )

$$V_{r2}^2 = V_2^2 + u_2^2 - 2u_2 V_2 \cos \alpha_2$$

$$\text{or} \quad u_2 V_2 \cos \alpha_2 = u_2 V_{u2} = (V_2^2 - u_2^2 + V_{r2}^2)/2 \quad (\text{B})$$

Substituting in Euler equation,

Power per unit flow rate (here the  $V_{u2}$  is in the opposite to  $V_{u1}$ )

$$\dot{m}(u_1 V_{u1} + u_2 V_{u2}) = \dot{m} \frac{1}{2} [(V_1^2 - V_2^2) + (u_1^2 - u_2^2) + (V_{r2}^2 - V_{r1}^2)]$$

$\frac{V_1^2 - V_2^2}{2}$  is the dynamic component of work done

$\frac{u_1^2 - u_2^2}{2}$  is the centrifugal component of work and this will be present only in the

radial flow machines

$\frac{V_{r2}^2 - V_{r1}^2}{2}$  is the accelerating component and this will be present only in the reaction

turbines.

**The first term only will be present in Pelton** or impulse turbine of tangential flow type.

In pure reaction turbines, the last two terms only will be present.

In impulse reaction turbines of radial flow type, all the terms will be present. (Francis turbines is of this type).

In impulse reaction turbines, the degree of reaction is defined by the ratio of energy converted in the rotor and total energy converted.

$$R = \frac{(u_1^2 - u_2^2) + (V_{r2}^2 - V_{r1}^2)}{(V_1^2 - V_2^2) + (u_1^2 - u_2^2) + (V_{r2}^2 - V_{r1}^2)} \quad (14.5.5)$$

The degree of reaction is considered in detail in the case of steam turbines where speed reduction is necessary. Hydraulic turbines are generally operate of lower speeds and hence degree of reaction is not generally considered in the discussion of hydraulic turbines.

## 14.6 PELTON TURBINE

This is the only type used in high head power plants. This type of turbine was developed and patented by L.A. Pelton in 1889 and all the type of turbines are called by his name to honour him.

A sectional view of a horizontal axis Pelton turbine is shown in figure 14.6.1. The main components are (1) The runner with the (vanes) buckets fixed on the periphery of the same. (2) The nozzle assembly with control spear and deflector (3) Brake nozzle and (4) The casing.

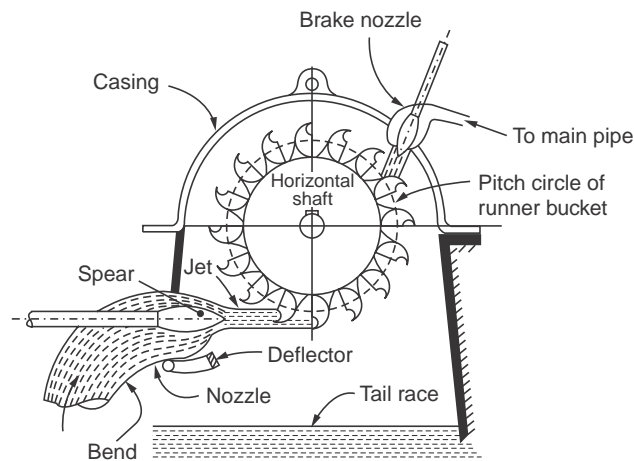

Figure 14.6.1 Pelton turbine

The rotor or runner consists of a circular disc, fixed on suitable shaft, made of cast or forged steel. Buckets are fixed on the periphery of the disc. The spacing of the buckets is decided by the runner diameter and jet diameter and is generally more than 15 in number. These buckets in small sizes may be cast integral with the runner. In larger sizes it is bolted to the runner disc.

The buckets are also made of special materials and the surfaces are well polished. A view of a bucket is shown in figure 14.6.2 with relative dimensions indicated in the figure. Originally spherical buckets were used and pelton modified the buckets to the present shape. It is formed in the shape of two half ellipsoids with a splinter connecting the two. A cut is made in the lip to facilitate all the water in the jet to usefully impinge on the buckets. This avoids interference of the incoming bucket on the jet impinging on the previous bucket. Equations are available to calculate the number of buckets on a wheel. The number of buckets,  $Z$ ,

$$Z = (D/2d) + 15$$

where  $D$  is the runner diameter and  $d$  is the jet diameter.

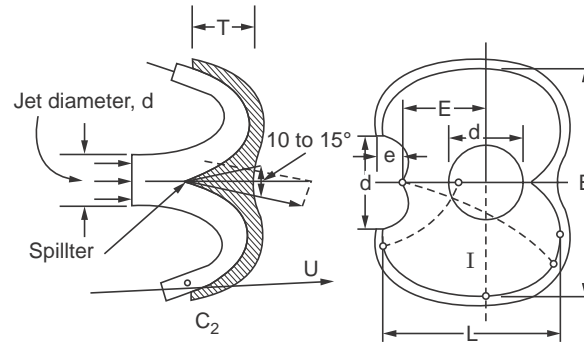

Figure 14.6.2 Pelton turbine bucket

Bucket and wheel dimensions

$D/d$	$B/d$	$L/d$	$T/d$	Notch width
14 – 16	2.8 – 4	2.5 – 2.8	0.95	$1.1 d + 5 \text{ mm}$

#### The nozzle and controlling spear and deflector assembly

The head is generally constant and the jet velocity is thus constant. A fixed ratio between the jet velocity and runner peripheral velocity is to be maintained for best efficiency. The nozzle is designed to satisfy the need. But the load on the turbine will often fluctuate and some times sudden changes in load can take place due to electrical circuit tripping. The velocity of the jet should not be changed to meet the load fluctuation due to frequency requirements. The quantity of water flow only should be changed to meet the load fluctuation. A governor moves to and fro a suitably shaped spear placed inside the nozzle assembly in order to change the flow rate at the same time maintaining a compact circular jet.

When load drops suddenly, the water flow should not be stopped suddenly. Such a sudden action will cause a high pressure wave in the penstock pipes that may cause damage to the system. To avoid this a deflector as shown in figure 14.6.3 is used to suddenly play out and deflect the jet so that the jet bypasses the buckets. Meanwhile the spear will move at the safe rate and close the nozzle and stop the flow. The deflector will then move to the initial position. Even when the flow is cut off, it will take a long time for the runner to come to rest due to the high inertia. To avoid this a braking jet is used which directs a jet in the opposite direction and stops the rotation. The spear assembly with the deflector is shown in figure 14.6.3. Some other methods like auxiliary waste nozzle and tilting nozzle are also used for speed regulation. The first wastes water and the second is mechanically complex. In side **the casing** the pressure is atmospheric and hence no need to design the casing for pressure. It mainly serves the purpose of providing a cover and deflecting the water downwards. The casing is cast in two halves for ease of assembly. The casing also supports the bearing and as such should be sturdy enough to take up the load.

When the condition is such that the specific speed indicates more than one jet, a vertical shaft system will be adopted. In this case the shaft is vertical and a horizontal nozzle ring with several nozzle is used. The jets in this case should not interfere with each other.

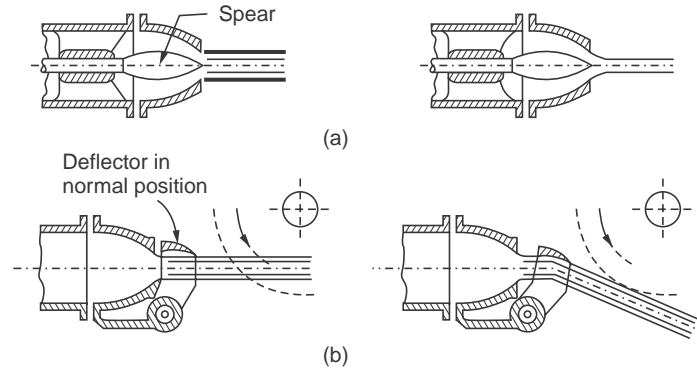

Figure 14.6.3 Nozzle assembly

Generally the turbine directly drives the generator. The speed of the turbine is governed by the frequency of AC. Power used in the region. The product of the pairs of poles used in the generator and the speed in rps gives the number of cycles per second. Steam turbines operate at 3000 rpm or 50 rps in the areas where the AC frequency is 50 cycles per second. Hydraulic turbines handle heavier fluid and hence cannot run at such speeds. In many cases the speed in the **range to 500 rpm**. As the water flows out on both sides equally axial thrust is minimal and heavy thrust bearing is not required.

### 14.6.1 Power Development

The bucket splits the jet into equal parts and changes the direction of the jet by about  $165^\circ$ . The velocity diagram for Pelton turbine is shown in figure 14.6.4.

The diagram shown is for the conditions  $V_{r2} \cos \beta > u$ , and  $V_2 \cos \alpha_2$  is in the opposite direction to  $V_{u1}$  and hence  $\Delta V_{u1}$  is additive.

In this case the jet direction is parallel to the blade velocity or the tangential velocity of the runner.

$$\text{Hence} \quad V_{u1} = V_1 \quad (\text{A})$$

$$\text{and} \quad V_{r1} = V_1 - u \quad (\text{B})$$

In the ideal case  $V_{r2} = V_{r1}$ . But due to friction  $V_{r2} = k V_{r1}$  and  $u_2 = u_1$ .

$$F = \dot{m} (V_{u1} \pm V_{u2}) \quad (14.6.1)$$

$$\tau = \dot{m} (V_{u1} \pm V_{u2}) r \quad (14.6.2)$$

$$P = \dot{m} (V_{u1} \pm V_{u2}) u \quad (14.6.3)$$

where  $\dot{m}$  is given by  $\rho AV$  at entry.

Hydraulic efficiency

$$\eta_h = \frac{\dot{m} (V_{u1} \pm V_{u2}) u}{\dot{m} V_1^2 / 2} = \frac{2u (V_{u1} \pm V_{u2})}{V_1^2} \quad (14.6.4)$$

Once the effective head of turbine entry is known  $V_1$  is fixed given by  $V_1 = C_v \sqrt{2gH}$ . For various values of  $u$ , the power developed and the hydraulic efficiency will be different. In fact the out let triangle will be different from the one shown if  $u > V_{r2} \cos \beta$ . In this case  $V_{u2}$  will be in the same direction as  $V_{u1}$  and hence the equation (14.6.3) will read as

$$P = \dot{m} (V_{u1} - V_{u2}) u$$

It is desirable to arrive at the optimum value of  $u$  for a given value of  $V_1$ . Equation 14.6.4 can be modified by using the following relations.

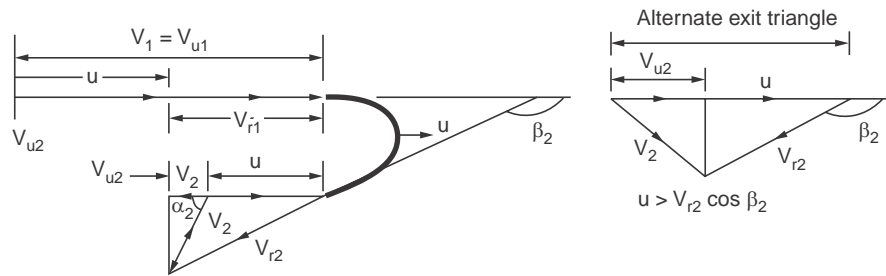

Figure 14.6.4 Velocity triangles Pelton turbine

$$\begin{aligned} V_{u1} &= V_1, V_{u2} = V_{r2} \cos \beta_2 - u = kV_{r1} \cos \beta_2 - u = k(V_1 - u) \cos \beta_2 - u \\ \therefore V_{u1} + V_{u2} &= V_1 + k V_1 \cos \beta_2 - u \cos \beta_2 - u \\ &= V_1 (1 + k \cos \beta_2) - u(1 + k \cos \beta_2) \\ &= (1 + k \cos \beta_2) (V_1 - u) \end{aligned}$$

Substituting in equation (14.6.4)

$$\begin{aligned} \eta_H &= \frac{2u}{V_1^2} \times (1 + k \cos \beta_2) (V_1 - u) \quad (14.6.4a) \\ &= 2(1 + k \cos \beta_2) \left[ \frac{u}{V_1} - \frac{u^2}{V_1^2} \right] \end{aligned}$$

$\frac{u}{V_1}$  is called speed ratio and denoted as  $\phi$ .

$$\therefore \eta_H = 2(1 + k \cos \beta_2) [\phi - \phi^2] \quad (14.6.5)$$

To arrive at the optimum value of  $\phi$ , this expression is differentiated with respect to  $\phi$  and equated to zero.

$$\frac{d\eta_H}{d\phi} = 2(1 + k \cos \beta_2) (1 - 2\phi)$$

$$\therefore \phi = \frac{u}{V_1} = \frac{1}{2} \quad \text{or} \quad u = 0.5 V_1 \quad (14.6.6)$$

**In practice the value is some what lower at  $u = 0.46 V_1$**

Substituting equation (14.6.6) in (14.6.4a) we get

$$\eta_H = 2(1 + k \cos \beta_2) [0.5 - 0.5^2]$$



$$= \frac{1 + k \cos \beta_2}{2}$$

It may be seen that in the case  $k = 1$  and  $\beta = 180^\circ$ ,

$$\eta_H = 1 \quad \text{or} \quad 100 \text{ percent.}$$

But the actual efficiency in well designed units lies between 85 and 90%.

**Example 14.8.** *The head available at a plant location is 500 m. For various values of  $\phi$  determine the work done 1 kg. Assume  $\beta_2 = 165^\circ$  and  $C_v = 0.97$ ,  $V_{r2} = V_{r1}$ .*

$$V_j = 0.97 \sqrt{2 \times 9.81 \times 500} = 96 \text{ m/s}$$

1.  $\phi = 0.2$ ,  $u = 19.2$ ,  $V_{r1} = 76.8 \text{ m/s} = V_{r2}$   
 $V_{w2} = (76.8 \times \cos 15 - 19.2) = 54.98$   
 $W = (96 + 54.98) \times 19.2 = \mathbf{2898.8 \text{ Nm/kg/s}}$
2.  $\phi = 0.3$ ,  $u = 28.8$ ,  $V_{r1} = 67.2 = V_{r2}$   
 $V_{w2} = (67.2 \times \cos 15 - 28.8) = 36.11 \text{ m/s}$   
 $W = (96 + 36.11) \times 28.8 = \mathbf{3804.8 \text{ Nm/kg/s}}$
3.  $\phi = 0.4$ ,  $u = 38.4$ ,  $V_{r1} = V_{r2} = 57.6 \text{ m/s}$   
 $V_{w2} = (57.6 \cos 15 - 38.4) = 17.24$   
 $W = (96 + 17.24) \times 38.4 = \mathbf{4348.3 \text{ Nm/kg/s}}$
4.  $\phi = 0.45$ ,  $u = 43.2$ ,  $V_{r1} = V_{r2} = 52.8$   
 $V_{w2} = (52.8 \cos 15 - 43.2) = 7.8$   
 $W = (96 + 7.8) \times 43.2 = \mathbf{4484 \text{ Nm/kg/s}}$
5.  $\phi = 0.5$ ,  $u = 48$ ,  $V_{r1} = V_{r2} = 48$   
 $V_{w2} = (48 \cos 15 - 48) = -1.64$   
 $W = (96 - 1.64) \times 48 = \mathbf{4529 \text{ Nm/kg/s}}$
6.  $\phi = 0.6$ ,  $u = 57.6$ ,  $V_{r1} = V_{r2} = 38.4$   
 $V_{w2} = (38.4 \cos 15 - 57.6) = -20.5$   
 $W = (96 - 20.5) \times 57.6 = \mathbf{4348.3 \text{ Nm/kg/s}}$
7.  $\phi = 0.7$ ,  $u = 67.2$ ,  $V_{r1} = V_{r2} = 28.8$   
 $V_{w2} = (28.8 \cos 15 - 67.2) = -39.4$   
 $W = (96 - 39.4) \times 67.2 = \mathbf{3804.8 \text{ Nm/kg/s}}$
8.  $\phi = 0.8$ ,  $u = 76.8$ ,  $V_{r1} = V_{r2} = 19.2$   
 $V_{w2} = (19.2 \cos 15 - 76.8) = -58.3$   
 $W = (96 - 58.3) \times 76.8 = \mathbf{2898.8 \text{ Nm/kg/s}}$

The result is shown plotted in Figure 14.6.5.

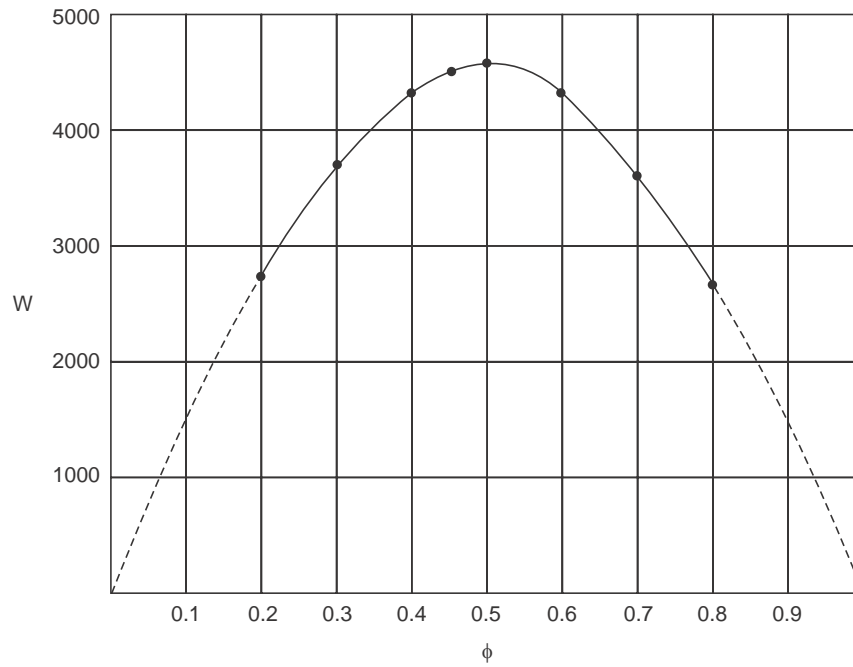

**Figure 14.6.5** Variation of power with variation of  $\phi$  for constant jet velocity

The shape of the velocity diagram at exit up to  $\phi = 0.45$  is given by Fig. 14.6.6 (a) and beyond  $\phi = 10.4$  by Fig 14.6.6 (b)

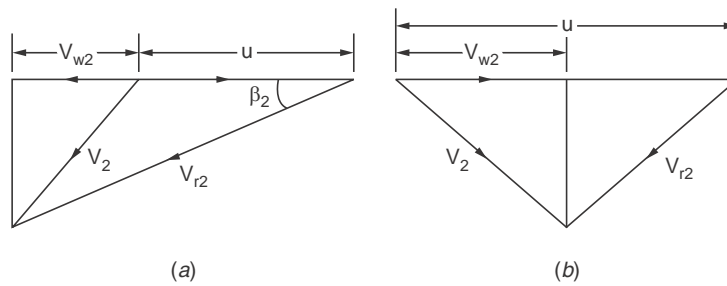

**Figure 14.6.6** Exit velocity diagrams for pelton turbine

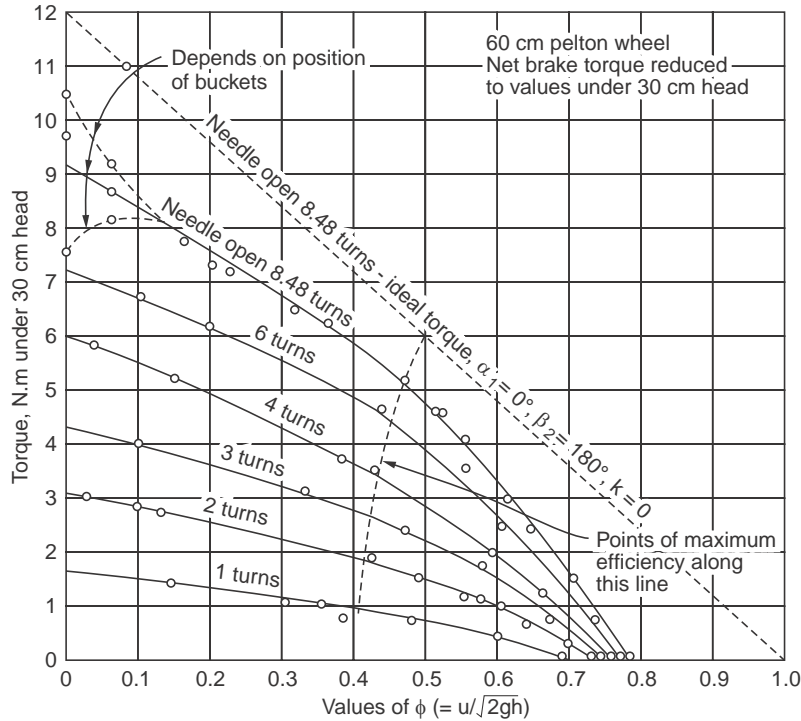

Figure 14.6.7 Relation between torque and speed ratio at constant head for various nozzle openings.

### 14.6.2 Torque and Power and Efficiency Variation with Speed Ratio

It is useful to study the variation torque with speed. Instead of speed the dimensionless speed ratio  $\phi$  can be used for generality. In the ideal case the torque will be maximum at  $u = 0$  or  $\phi = 0$  and zero at  $\phi = 1$ , or  $u = V_1$ . **The actual variation of torque with speed ratio is shown in figure 14.6.7.** It is noted that the maximum efficiency lies in all cases between  $\phi = 0.4$  and  $0.5$ . Also torque is found to be zero at values less than  $\phi = 1$ . This is done to friction and exit loss ( $V_2^2/2$ ) variation with various values of  $u$ .

**The power variation for constant value of  $V_1$  with  $\phi$  is shown in figure 14.6.8.**

The power can be calculated from the torque curves. In the ideal case power is zero both at  $\phi = 0$  and  $\phi = 1$ . In the actual case power is zero even at  $\phi$  is between  $0.7$  and  $0.8$ . As the torque versus  $\phi$  is not a straight line, the actual power curve is not a parabola.

The efficiency variation with speed ratio is similar to power versus speed ratio curve as the input  $V_1^2/2$  is the same irrespective of  $u/V_1$ . Efficiency is some what higher in larger sizes as compared to small sizes homologous units. But this does not increase in the same proportion as the size. At higher heads any unit will operate at a slightly higher efficiency.

It is interesting to observe the variation of efficiency with load at a constant speed (Figure 14.6.9). Most units operate at a constant speed but at varying loads. The curve is rather flat and hence impulse turbine can be operated at lower loads with reduced losses.

It can be shown that the specific speed of impulse turbine is dependent on the jet diameter, ( $d$ ) wheel diameter ( $D$ ) ratio or called jet ratio in short.

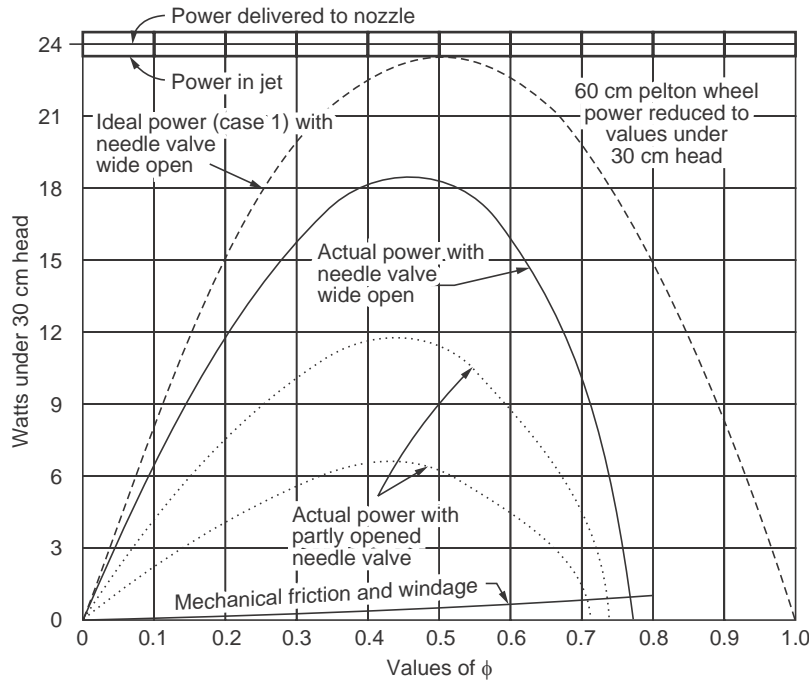

Figure 14.6.8 Speed ratio  $V_s$  power developed by pelton turbine

$$N_s \propto \frac{N \sqrt{P}}{H^{5/4}}$$

$$N \propto \frac{u}{D} \propto \frac{\phi}{D} V_1 \propto \frac{\phi \sqrt{H}}{D}$$

$$P \propto Q H \propto d_2 V_1 H \propto d^2 \sqrt{H} H \propto d^2 H^{3/2}$$

$$\sqrt{P} \propto d H^{3/4}$$

$$\therefore N_s \propto \frac{\phi H^{1/2} d \cdot H^{3/4}}{H^{5/4}} \propto \phi \frac{d}{D} = \text{constant } \phi \frac{d}{D}$$

where  $d$  is the jet diameter.  $\phi$  does not vary much and the constant made up of efficiency and  $C_v$  also does not vary much. Hence specific speed of an impulse turbine is mainly dependent on the jet diameter wheel diameter ratio. Inversely at the specific speed at which efficiency is maximum, there is a specific value of jet speed wheel speed ratio. For single nozzle unit, the best value of dimensional specific speed is about 17 and at that condition the wheel diameter is about 12 times the jet diameter. This is shown in figure 17.6.10.

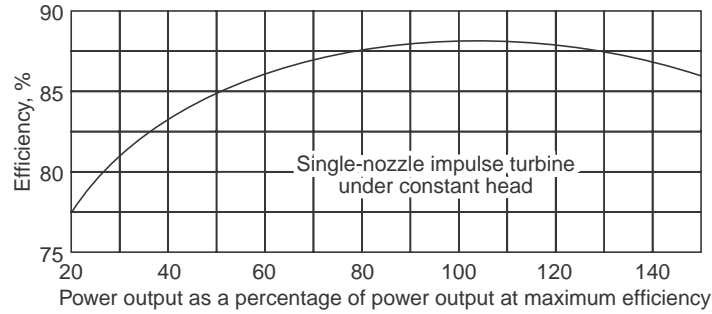

Figure 14.6.9 Variation of efficiency with load of constant speed for an impulse turbine.

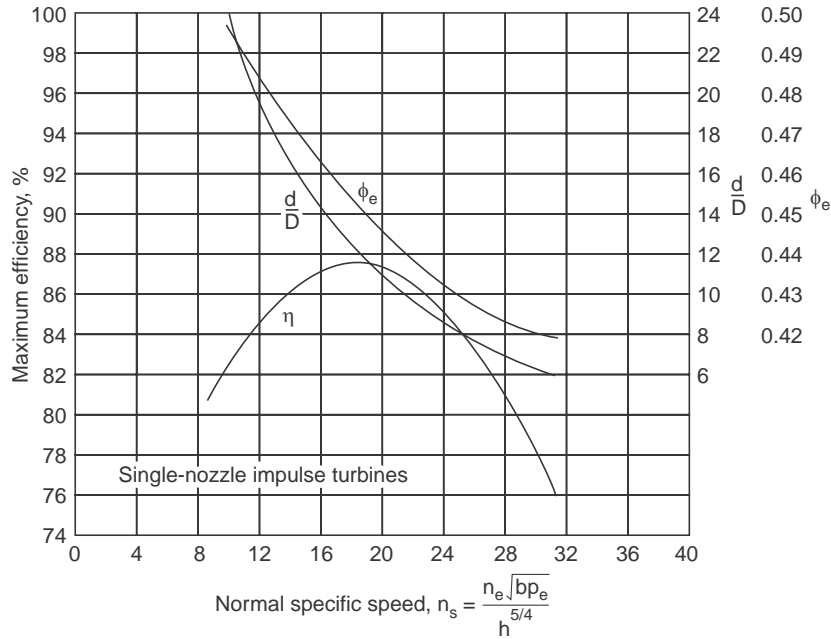

Figure 14.6.10 Variation of efficiency at the  $\frac{D}{d}$  ratio for single jet impulse turbine

### 14.7 REACTION TURBINES

The functioning of reaction turbines differs from impulse turbines in two aspects.

1. In the impulse turbine the potential energy available is completely converted to kinetic energy by the nozzles before the water enters the runner. The pressure in the runner is constant at atmospheric level.

In the case of reaction turbine the potential energy is partly converted to kinetic energy in the stator guide blades. The remaining potential energy is gradually converted to kinetic energy and absorbed by the runner. The pressure inside the runner varies along the flow.

2. In the impulse turbine only a few buckets are engaged by the jet at a time.

In the reaction turbine as it is fully flowing all blades or vanes are engaged by water at all the time. The other differences are that reaction turbines are well suited for low and medium heads (300 m to below) while impulse turbines are well suited for high heads above this value.

Also due to the drop in pressure in the vane passages in the reaction turbine the relative velocity at outlet is higher compared to the value at inlet. In the case of impulse turbine there is no drop in pressure in the bucket passage and the relative velocity either decreases due to surface friction or remains constant. In the case of reaction turbine the flow area between two blades changes gradually to accommodate the change in static pressure. In the case of impulse turbine the speed ratio for best efficiency is fixed as about 0.46. As there is no such limitation, reaction turbines can be run at higher speeds.

### 14.7.1 Francis Turbines

Francis turbine is a radial inward flow turbine and is the most popularly used one in the medium head range of 60 to 300 m. Francis turbine was first developed as a purely radial flow turbine by James B. Francis, an American engineer in 1849. But the design has gradually changed into a mixed flow turbine of today.

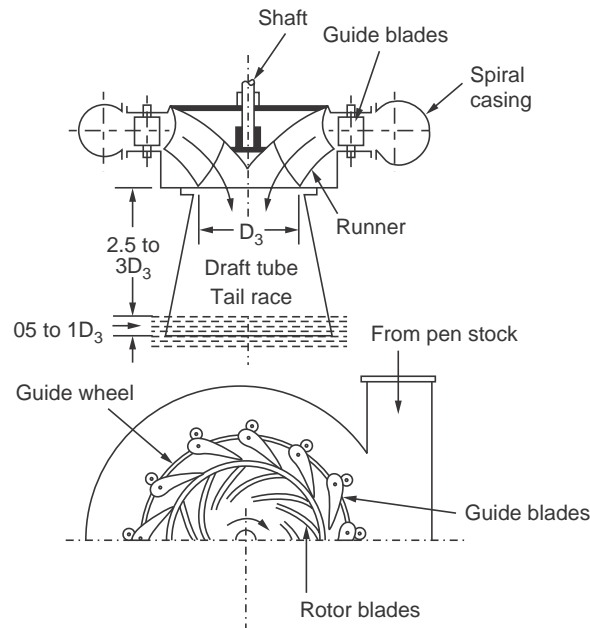

**Figure 14.7.1** Typical sectional and front view of a modern Francis turbine.

A sectional view of a typical Francis turbine of today is shown in figure 14.7.1.

The main components are (i) The spiral casing (ii) Guide vanes (iii) Runner (iv) Draft tube and (v) Governor mechanism. Most of the machines are of vertical shaft arrangement while some smaller units are of horizontal shaft type.

### 14.7.1.1 Spiral Casing

The spiral casing surrounds the runner completely. Its area of cross section decreases gradually around the circumference. This leads to uniform distribution of water all along the circumference of the runner. Water from the penstock pipes enters the spiral casing and is distributed uniformly to the guide blades placed on the periphery of a circle. The casing should be strong enough to withstand the high pressure.

### 14.7.1.2 Guide Blades

Water enters the runner through the guide blades along the circumference. The number of guide blades are generally fewer than the number of blades in the runner. These should also be not simple multiples of the runner blades. The guide blades in addition to guiding the water at the proper direction serves two important functions. The water entering the guide blades are imparted a tangential velocity by the drop in pressure in the passage of the water through the blades. **The blade passages act as a nozzle in this aspect.**

The guide blades rest on pivoted on a ring and can be rotated by the rotation of the ring, whose movement is controlled by the governor. In this way the area of blade passage is changed to vary the flow rate of water according to the load so that the speed can be maintained constant. The variation of area between guide blades is illustrated in Figure 14.7.2. The control mechanism will be discussed in a later section.

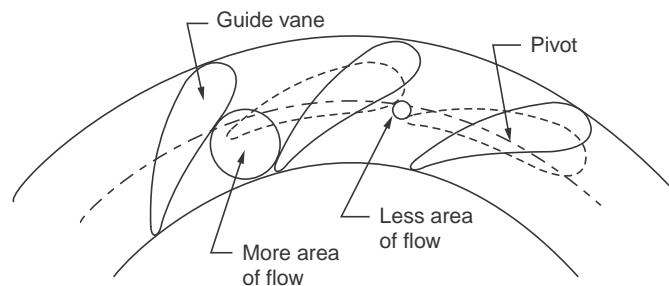

Figure 14.7.2. Guide vane and guide wheel

### 14.7.1.3 The Runner

The runner is circular disc and has the blades fixed on one side. In high speed runners in which the blades are longer a circular band may be used around the blades to keep them in position.

The shape of the runner depends on the specific speed of the unit. These are classified as (a) slow runner (b) medium speed runner (c) high speed runner and (d) very high speed runner.

The shape of the runner and the corresponding velocity triangles are shown in figure 14.7.3. The development of mixed flow runners was necessitated by the limited power capacity of the purely radial flow runner. A larger exit flow area is made possible by the change of shape from radial to axial flow shape. This reduces the outlet velocity and thus increases efficiency. As seen in the figure the velocity triangles are of different shape for different runners. It is seen from the velocity triangles that the blade inlet angle  $\beta_1$  changes from acute to obtuse as the speed increases. The guide vane outlet angle  $\alpha_1$  also increases from about  $15^\circ$  to higher values as speed increases.

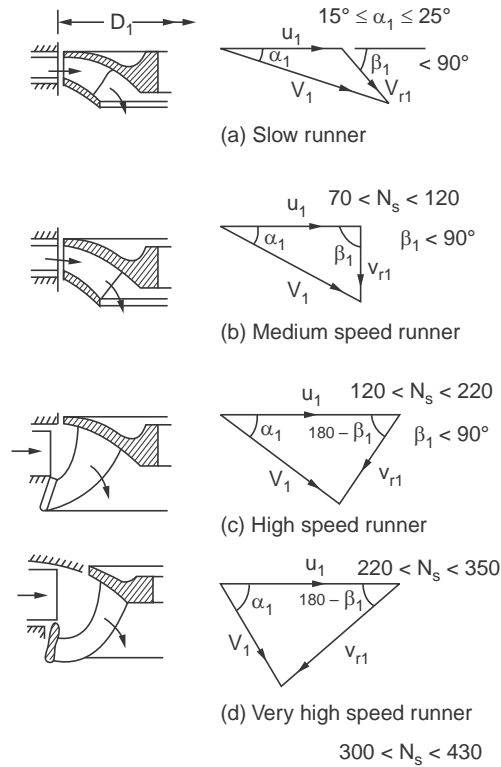

Figure 14.7.3 Variation of runner shapes and inlet velocity triangles with specific speed

In all cases, the outlet angle of the blades are so designed that there is no whirl component of velocity at exit ( $V_{u2} = 0$ ) or absolute velocity at exit is minimum.

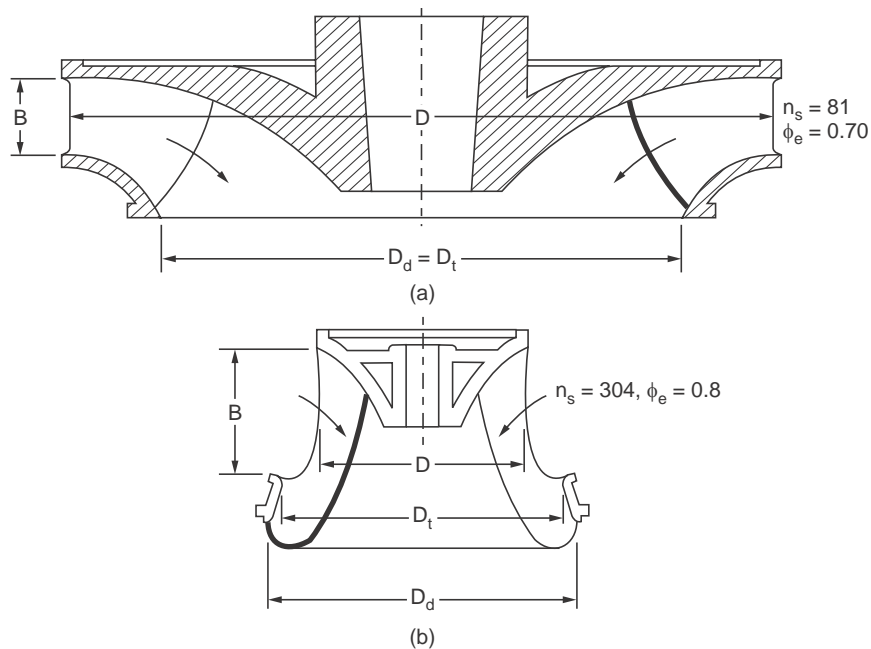

Figure 14.7.4 Slow speed and high speed runner shapes.



The runner blades are of doubly curved and are complex in shape. These may be made separately using suitable dies and then welded to the rotor. The height of the runner along the axial direction (may be called width also) depends upon the flow rate which depends on the head and power which are related to specific speed. As specific speed increases the width also increase accordingly. Two such shapes are shown in figure 7.1.4.

The runners change the direction and magnitude of the fluid velocity and in this process absorb the momentum from the fluid.

#### 14.7.1.4 Draft Tube

The turbines have to be installed a few meters above the flood water level to avoid inundation. In the case of impulse turbines this does not lead to significant loss of head. In the case of reaction turbines, the loss due to the installation at a higher level from the tailrace will be significant. This loss is reduced by connecting a fully flowing diverging tube from the turbine outlet to be immersed in the tailrace at the tube outlet. This reduces the pressure loss as the pressure at the turbine outlet will be below atmospheric due to the arrangement. **The loss in effective head is reduced by this arrangement. Also because of the diverging section of the tube the kinetic energy is converted to pressure energy which adds to the effective head.** The draft tube thus helps (1) to regain the lost static head due to higher level installation of the turbine and (2) helps to recover part of the kinetic energy that otherwise may be lost at the turbine outlet. A draft tube arrangement is shown in Figure 14.7.1 (as also in figure 14.7.5). Different shapes of draft tubes is shown in figure 14.7.6.

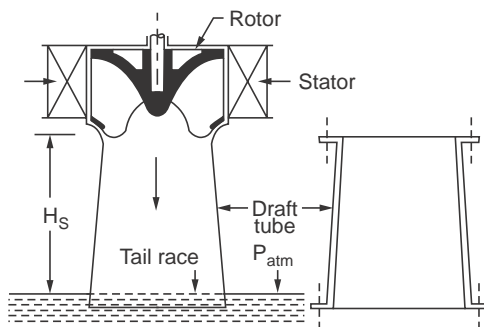

Figure 14.7.5 Draft tube

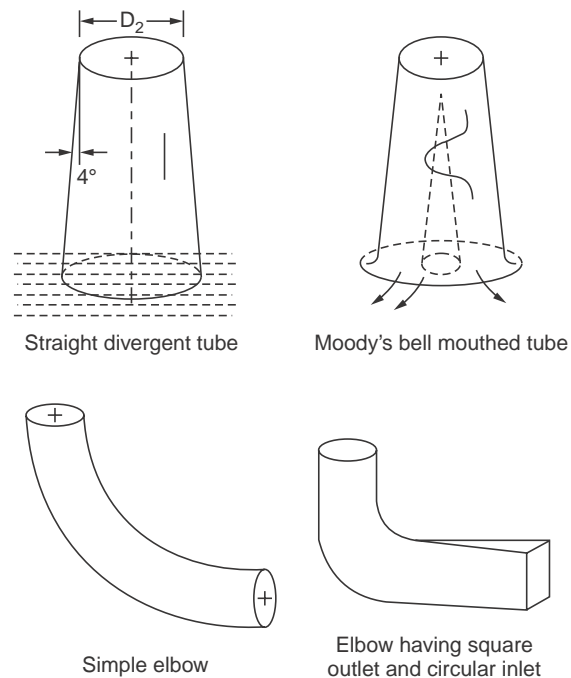

Figure 14.7.6 Various shapes of draft tubes

The head recovered by the draft tube will equal the sum of the height of the turbine exit above the tail water level and the difference between the kinetic head at the inlet and outlet of the tube less frictional loss in head.

$$H_d = H + (V_1^2 - V_2^2)/2g - h_f$$

where  $H_d$  is the gain in head,  $H$  is the height of turbine outlet above tail water level and  $h_f$  is the frictional loss of head.

Different types of draft tubes are used as the location demands. These are (i) Straight diverging tube (ii) Bell mouthed tube and (iii) Elbow shaped tubes of circular exit or rectangular exit.

Elbow types are used when the height of the turbine outlet from tailrace is small. Bell mouthed type gives better recovery. The divergence angle in the tubes should be less than  $10^\circ$  to reduce separation loss.

The height of the draft tube will be decided on the basis of cavitation. This is discussed in a later section.

The efficiency of the draft tube in terms of recovery of the kinetic energy is defined as

$$\eta = \frac{V_1^2 - V_2^2}{V_1^2}$$

where  $V_1$  is the velocity at tube inlet and  $V_2$  is the velocity at tube outlet.

### 14.7.1.5 Energy Transfer and Efficiency

A typical velocity diagrams at inlet and outlet are shown in Figure 14.7.7.

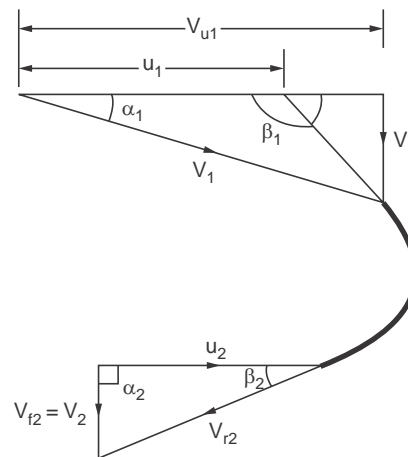

Figure 14.7.7 Velocity diagram for Francis runner

Generally as flow rate is specified and the flow areas are known, it is directly possible to calculate  $V_{f1}$  and  $V_{f2}$ . Hence these may be used as the basis in calculations. By varying the widths at inlet and outlet suitably the flow velocity may be kept constant also.

From Euler equation, power

$$P = \dot{m} (V_{u1} u_1 - V_{u2} u_2)$$

where  $\dot{m}$  is the mass rate of flow equal to  $Q \rho$  where  $Q$  is the volume flow rate. As  $Q$  is more easily calculated from the areas and velocities,  $Q \rho$  is used by many authors in place of  $\dot{m}$ .

In all the turbines to minimise energy loss in the outlet the absolute velocity at outlet is minimised. This is possible only if  $V_2 = V_{f2}$  and then  $V_{u2} = 0$ .

$$\therefore P = \dot{m} V_{u1} u_1$$

For unit flow rate, the energy transferred from fluid to rotor is given by

$$E_1 = V_{u1} u_1$$

The energy available in the flow per kg is

$$E_a = g H$$

where  $H$  is the effective head available.

Hence the hydraulic efficiency is given by

$$\eta_H = \frac{V_{u1} u_1}{g H}$$

It friction and expansion losses are neglected

$$W = g H - \frac{V_2^2}{2g}$$

$\therefore$  It may be written in this case

$$\eta = \frac{gH - \frac{V_2^2}{2g}}{gH} = 1 - \frac{V_2^2}{2gH}$$

The values of other efficiencies are as in the impulse turbine *i.e.* volumetric efficiency and mechanical efficiency and over all efficiency.

$$V_{f1} = Q / \pi (D_1 - zt) b_1 \quad \Omega = Q / \pi D_1 b_1 \quad (\text{neglecting blade thickness})$$

$$V_{u1} = u_1 + V_{f1} / \tan \beta_1 = u_1 + V_{f1} \cot \beta_1$$

$$= \frac{\pi D_1 N}{60} + V_{f1} \cot \beta_1$$

$$u_1 = \frac{\pi D_1 N}{60}$$

$\therefore V_{u1} u_1$  can be obtained from  $Q_1, D_1, b_1$  and  $N_1$

For other shapes of triangles, the + sign will change to – sign as  $\beta_2$  will become obtuse.

### Runner efficiency or Blade efficiency

This efficiency is calculated not considering the loss in the guide blades.

From velocity triangle :

$$V_{u1} = V_{f1} \cot \alpha_1$$

$$u_1 = V_f [\cot \alpha_1 + \cot \beta_1]$$

$$\therefore u_1 V_{u1} = V_{f1}^2 \cot \alpha_1 [\cot \alpha_1 + \cot \beta_1]$$

Energy supplied to the runner is

$$u_1 V_{u1} + \frac{V_2^2}{2} = u_1 V_{u1} + \frac{V_{f2}^2}{2} = u_1 V_{u1} + \frac{V_{f1}^2}{2}$$

(Assume  $V_{f2} = V_{f1}$ )

$$\therefore \eta_b = \frac{V_{f1}^2 \cot \alpha_1 [\cot \alpha_1 + \cot \beta_1]}{\frac{V_{f1}^2}{2} + V_{f1}^2 \cot \alpha_1 [\cot \alpha_1 + \cot \beta_1]}$$

Multiply by 2 and add and subtract  $V_{f1}^2$  in the numerator to get

$$\eta_b = 1 - \frac{1}{1 + 2 \cot \alpha_1 (\cot \alpha_1 + \cot \beta_1)}$$

In case  $\beta_1 = 90^\circ$

$$\eta_b = 1 - \frac{1}{1 + \frac{2}{\tan^2 \alpha_1}} = \frac{2}{2 + \tan^2 \alpha_1}$$

In this case  $V_{u1} = u_1$

The characteristics of Francis turbine is shown in Figure 14.7.8.

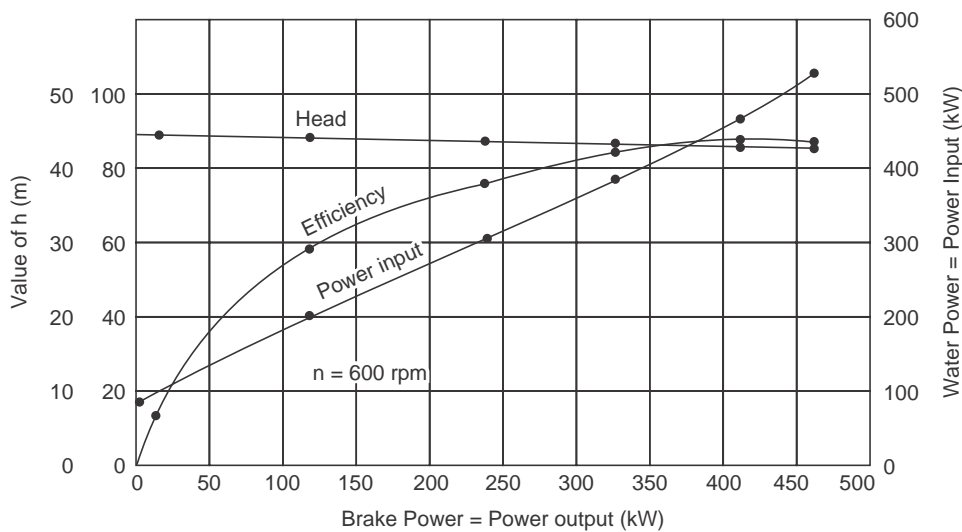

Figure 14.7.8

The efficiency curve is not as flat as that of impulse turbine. At part loads the efficiency is relatively low. There is a drop in efficiency after 100% load.

The characteristics of Francis turbine at various speeds but at constant head is shown in figure 14.7.9.

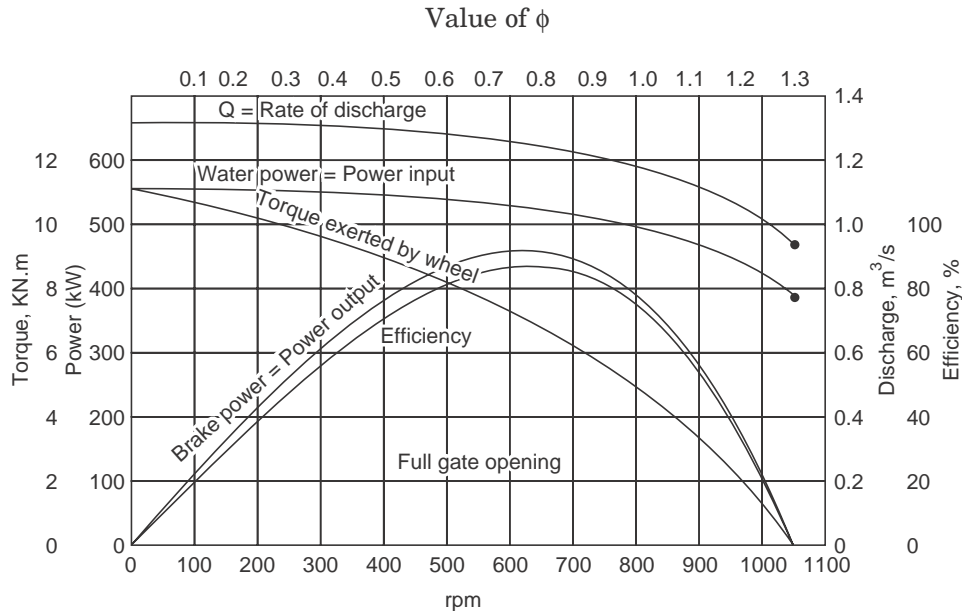

Figure 14.7.9 Francis turbine characteristics at variable speed and constant head

## 14.8 AXIAL FLOW TURBINES

The popular axial flow turbines are the Kaplan turbine and propeller turbine. In propeller turbine the blades are fixed. In the Kaplan turbines the blades are mounted in the boss in bearings and the blades are rotated according to the flow conditions by a servomechanism maintaining constant speed. In this way a constant efficiency is achieved in these turbines. The system is costly and where constant load conditions prevail, the simpler propeller turbines are installed.

In the discussions on Francis turbines, it was pointed out that as specific speed increases (more due to increased flow) the shape of the runner changes so that the flow tends towards axial direction. This trend when continued, the runner becomes purely axial flow type.

There are many locations where large flows are available at low head. In such a case the specific speed increases to a higher value. In such situations axial flow turbines are gainfully employed. A sectional view of a Kaplan turbine is shown in figure 14.8.1. These turbines are suited for head in the range 5 – 80 m and specific speeds in the range 350 to 900. The water from supply pipes enters the spiral casing as in the case of Francis turbine. Guide blades direct the water into the chamber above the blades at the proper direction. The speed governor in this case acts on the guide blades and rotates them as per load requirements. The flow rate is changed without any change in head. The water directed by the guide blades enters the runner which has much fewer blades (3 to 10) than the Francis turbine. The blades are also rotated by the governor to change the inlet blade angle as per the flow direction from the guide blades, so

that entry is without shock. As the head is low, many times the draft tube may have to be elbow type. The important dimensions are the diameter and the boss diameter which will vary with the chosen speed. At lower specific speeds the boss diameter may be higher.

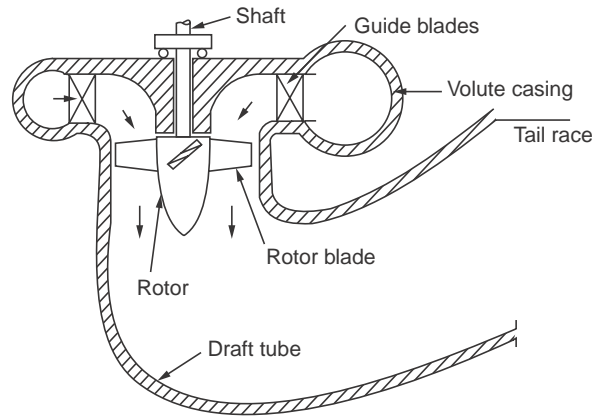

Figure 14.8.1 Sectional view of kaplan furbine

The number of blades depends on the head available and varies from 3 to 10 for heads from 5 to 70 m. As the peripheral speed varies along the radius (proportional to the radius) the blade inlet angle should also vary with the radius. Hence twisted type or Airfoil blade section has to be used. The speed ratio is calculated on the basis of the tip speed as  $\phi = u/\sqrt{2gH}$  and varies from 1.5 to 2.4. The flow ratio lies in the range 0.35 to 0.75.

Typical velocity diagrams at the tip and at the hub are shown in Figure 14.8.2. The diagram is in the axial and tangential plane instead of radial and tangential plane as in the other turbines.

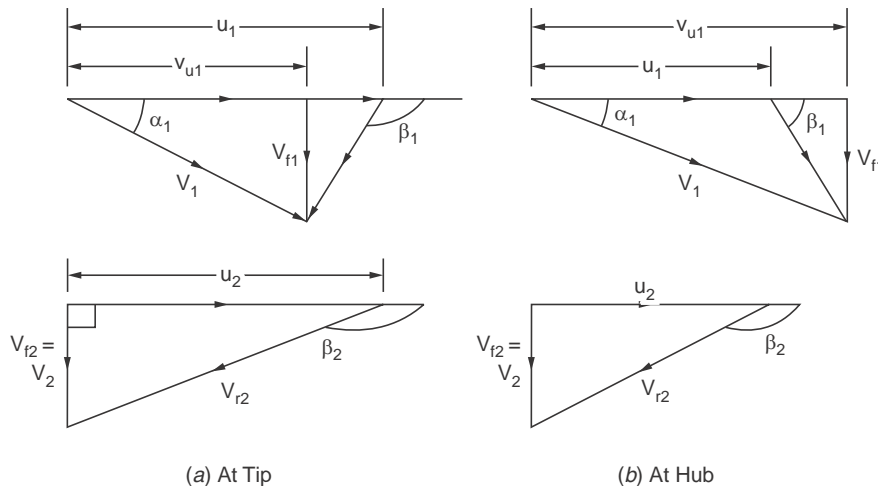

Figure 14.8.2 Typical velocity diagrams for Kaplan turbine

Work done =  $u_1 V_{u1}$  (Taken at the mean diameter)

$$\eta_H = \frac{u_1 V_{u1}}{g H}$$

All other relations defined for other turbines hold for this type also. The flow velocity remains constant with radius. As the hydraulic efficiency is constant all along the length of the blades,  $u_1 V_{u1} = \text{Constant}$  along the length of the blades or  $V_{u1}$  decreases with radius.

Kaplan turbine has a flat characteristics for variation of efficiency with load. Thus the part load efficiency is higher in this case. In the case of propeller turbine the part load efficiency suffers as the blade angle at these loads are such that entry is with shock.

The load efficiency characteristic of the four types of turbines is shown in figure 14.8.3.

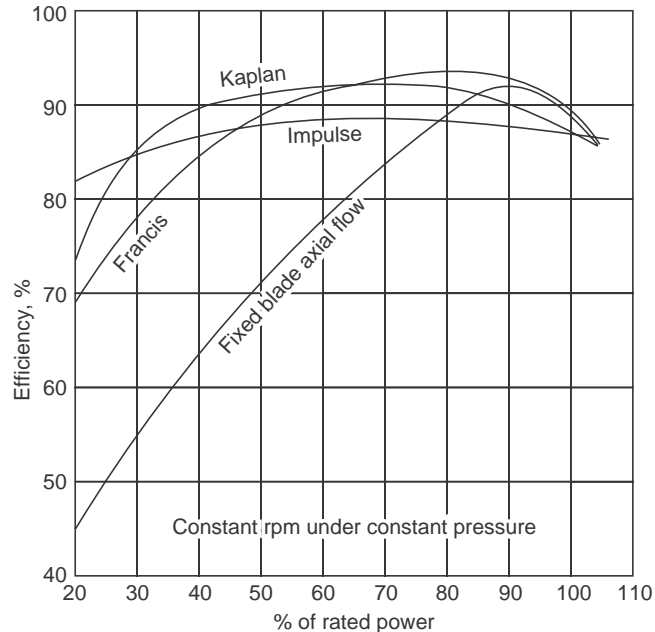

Figure 14.8.3 Load efficiency characteristics of hydraulic turbines

## 14.9 CAVITATION IN HYDRAULIC MACHINES

If at any point in the flow the pressure in the liquid is reduced to its vapour pressure, the liquid will then will boil at that point and bubbles of vapour will form. As the fluid flows into a region of higher pressure the bubbles of vapour will suddenly condense or collapse. This action produces very high dynamic pressure upon the adjacent solid walls and since the action is continuous and has a high frequency the material in that zone will be damaged. Turbine runners and pump impellers are often severely damaged by such action. The process is called cavitation and the damage is called cavitation damage. In order to avoid cavitation, the absolute pressure at all points should be above the vapour pressure.

Cavitation can occur in the case of reaction turbines at the turbine exit or draft tube inlet where the pressure may be below atmospheric level. In the case of pumps such damage may occur at the suction side of the pump, where the absolute pressure is generally below atmospheric level.

In addition to the damage to the runner cavitation results in undesirable vibration noise and loss of efficiency. The flow will be disturbed from the design conditions. In reaction turbines the most likely place for cavitation damage is the back sides of the runner blades near their trailing edge. The critical factor in the installation of reaction turbines is the vertical distance from the runner to the tailrace level. For high specific speed propeller units it may be desirable to place the runner at a level lower than the tailrace level.

To compare cavitation characteristics a cavitation parameter known as Thoma cavitation coefficient,  $\sigma$ , is used. It is defined as

$$\sigma = \frac{h_a - h_r - z}{h} \quad (14.8.1)$$

where  $h_a$  is the atmospheric head,  $h_r$  is the vapour pressure head,  $z$  is the height of the runner outlet above tail race and  $h$  is the total operating head. The minimum value of  $\sigma$  at which cavitation occurs is defined as critical cavitation factor  $\sigma_c$ . Knowing  $\sigma_c$  the maximum value of  $z$  can be obtained as

$$z = h_a - h_v - \sigma_c h \quad (14.8.2)$$

$\sigma_c$  is found to be a function of specific speed. In the range of specific speeds for Francis turbine  $\sigma_c$  varies from 0.1 to 0.64 and in the range of specific speeds for Kaplan turbine  $\sigma_c$  varies from 0.4 to 1.5. The minimum pressure at the turbine outlet,  $h_0$  can be obtained as

$$h_0 = h_a - z - \sigma_c H \quad (14.8.3)$$

There are a number of correlations available for the value of  $\sigma_c$  in terms of specific speed, obtained from experiments by Moody and Zowski. The constants in the equations depends on the system used to calculate specific speed.

$$\text{For Francis runners} \quad \sigma_c = 0.006 + 0.55 (N_s/444.6)^{1.8} \quad (14.8.4)$$

$$\text{For Kaplan runners} \quad \sigma_c = 0.1 + 0.3 [N_s/444.6]^{2.5} \quad (14.8.5)$$

Other empirical correlations are

$$\text{Francis runner} \quad \sigma_c = 0.625 \left[ \frac{N_s}{380.78} \right]^2 \quad (14.8.6)$$

$$\text{For Kaplan runner} \quad \sigma_c = 0.308 + \frac{1}{6.82} \left( \frac{N_s}{380.78} \right)^2 \quad (14.8.7)$$

**Example 14.9.** The total head on a Francis turbine is 20 m. The machine is at an elevation where the atmospheric pressure is 8.6 m. The pressure corresponding to the water temperature of 15° C is 0.17 m. Its critical cavitation factor is 0.3, determine the level of the turbine outlet above the tail race.

$$z = P_a - P_v - \sigma_c h = 8.6 - 0.17 - 0.3 \times 20 = \mathbf{2.43 \text{ m.}}$$

**The turbine outlet can be set at 2.43 m above the tailrace level.**



## 14.9 GOVERNING OF HYDRAULIC TURBINES

Hydraulic turbines drive electrical generators in power plants. The frequency of generation has to be strictly maintained at a constant value. This means that the turbines should run at constant speed irrespective of the load or power output. It is also possible that due to electrical tripping the turbine has to be stopped suddenly.

**The governing system takes care of maintaining the turbine speed constant irrespective of the load and also cutting off the water supply completely when electrical circuits trip.**

When the load decreases the speed will tend to rise if the water supply is not reduced. Similarly when suddenly load comes on the unit the speed will decrease. The governor should step in and restore the speed to the specified value without any loss of time.

The **governor should be sensitive** which means that it should be able to act rapidly even when the change in speed is small. At the same time **it should not hunt**, which means that there should be no ups and downs in the speed and stable condition should be maintained after the restoration of the speed to the rated value. It should not suddenly cut down the flow completely to avoid damage to penstock pipes.

In hydraulic power plants the available head does not vary suddenly and is almost constant over a period of time. So **governing can be achieved only by changing the quantity of water that flows into the turbine runner**. As already discussed the water flow in pelton turbines is controlled by the spear needle placed in the nozzle assembly. The movement of the spear is actuated by the governor to control the speed. In reaction turbines the guide vanes are moved such that the flow area is changed as per the load requirements.

**Hydraulic system is used to move the spear** in the nozzle or to change the positions of the guide blades because the force required is rather high.

The components of governing system are

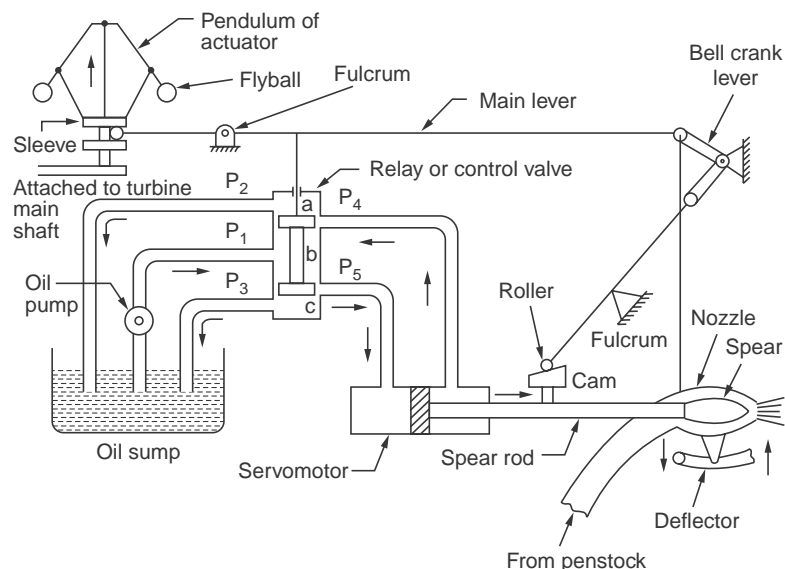

Figure 14.9.1 Governing system for Pelton turbine

(i) The speed sensing element which actuates the system (ii) Hydraulic power pack with suitable pump and valves. (iii) Distributing valve also called relay valve (iv) Power cylinder which provides the force required.

In the older systems a centrifugal governor was used as the sensing element. In the modern system electronic means of frequency detection is used to actuate the system.

The older type of system used in the case of pelton turbine is shown in figure 14.9.1.

The mechanical centrifugal governor is driven by the turbine shaft. The weights carry a sleeve which can move up and down the drive spindle. When the load decreases the turbine speeds up and the governor weights fly apart moving the sleeve up. The reverse happens when load increase on the turbine. The sleeve carries a lever which moves the control value in the relay cylinder. Oil under pressure is maintained at the central position of the relay cylinder. The top and bottom are connected on one side to the power cylinder and to the sump on the other side. Under steady load conditions the valve rod closes both inlets to the power cylinder and the spear remains at a constant position. When the turbine speeds up, the valve rod moves down connecting the oil supply to the left side of the power cylinder. The piston in the power cylinder moves to reduce the flow. At the same time the right side of the power cylinder is connected to the sump so that the oil in the right side can flow out. The opposite movement takes place when the turbine speed reduces.

As sudden cut off is not desirable, a deflector is actuated by suitable mechanism to deflect the flow when sudden and rapid increase in speed takes place.

In the case of reaction turbines, the power cylinder and the sensing system are the same. The guide vanes are mounted on a ring and so mounted that these rotate when the ring rotates. The rotation of the ring is actuated by the power cylinder when the load changes. This part of the system is shown in figure 14.9.2.

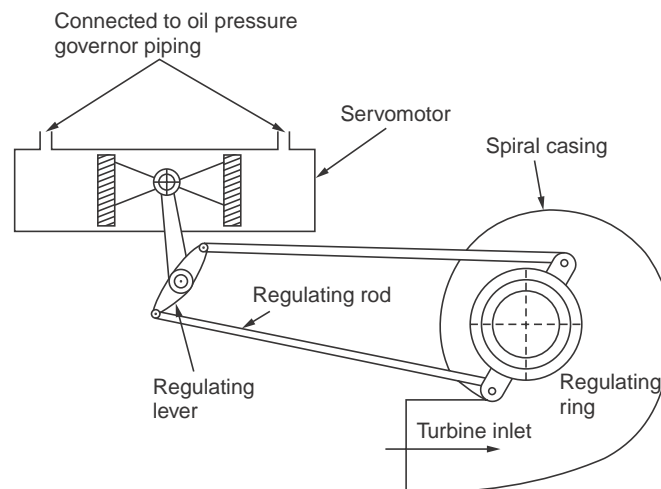

Figure 14.9.2 Reaction turbine governor linkage

### WORKED EXAMPLES

**Problem 14.1** A lawn sprinkler is shown in figure. The sectional area at outlet is  $1 \text{ cm}^2$ . The flow rate is  $1 \text{ l/s}$  on each side.

Calculate the angular speed of rotation and the torque required to hold it stationary. Neglect friction.

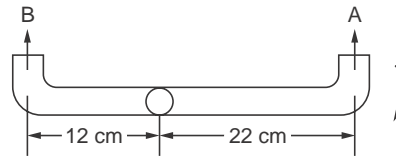

Figure P. 14.1

The flow velocity is  $10^{-3}/10^{-4} = 10 \text{ m/s}$ .

The jets A and B exert forces in the opposite direction. As arm A is longer the sprinkler will rotate in the clockwise direction. Let it rotate at an angular velocity  $\omega$ .

**The absolute velocity of**

$$\text{Jet A} = (10 - 0.22 \omega).$$

**The absolute velocity of jet B =  $10 + 0.12 \omega$**

As no external torque is applied and as there is no friction, the resultant torque is zero.

$$\therefore (10 - 0.22 \omega) 0.22 = (10 + 0.12 \omega) 0.12$$

Solving  $\omega = 15.923 \text{ radions/second}$

$$\omega = \frac{2 \pi N}{60}, \text{ Substituting and solving for } N$$

$$N = 152 \text{ rpm}$$

Torque when stationary : (as mass) flow is equal =  $1 \text{ kg/s}$

$$= 1(V_a r_a - V_B r_b) = 1(10 \times 0.22 - 10 \times 0.12)$$

$$= 1 \text{ Nm.}$$

**Problem 14.2** A  $20 \text{ cm}$  pipe  $600 \text{ m}$  long with friction factor of  $0.02$  carries water from a reservoir to a turbine with a difference in head of  $90 \text{ m}$ . The friction loss in the nozzle is  $0.05 V_s^2 / 2g$ . **Determine the diameter of the jet which will result in maximum power.**

The energy equation is

$$90 - \frac{600 \times 0.02 \times V_p^2}{2g \times 0.2} - \frac{0.05 V_j^2}{2g} = \frac{V_j^2}{2g}$$

$$90 \times 2 \times 9.81 - \frac{600 \times 0.02}{0.2} V_p^2 = 1.05 V_j^2$$

$$V_p = V_j D_j^2 / 0.2^2, V_p^2 = V_j^2 D_j^4 / 0.2^4 = 625 V_j^2 D_j^4$$

$$1765.8 - \frac{600 \times 625 \times 0.02}{0.2} \cdot V_j^2 D_j^4 = 1.05 V_j^2$$

or  $V_j^2 (1.05 + 37500 D_j^4) = 1765.8$

Solving by trial by assuming  $D_j$ , power in the jet is determined as  $\dot{m} V_j^2 / 2$

$D_j$ , m	$V_j$ , m/s	$\dot{m} = (\pi D_j^2/4) V_j \times 1000$	Power in jet = $\frac{\dot{m} V_1^2}{2} / 1000$ kW
0.04	40.92	51.40 kg/s	43.05 kW
0.06	33.90	95.85	50.07
0.08	26.39	132.60	46.19
0.10	19.18	150.64	27.7

**Maximum power is around  $D_j = 0.06$  m or 60 mm.**

**Problem 14.3** At a location selected for installation of a hydro electric plant, the head available was estimated as 115 m and water flow rate was estimated as  $15 \text{ m}^3/\text{s}$ . For convenience of maintenance it is desired to select two units for the plant. Select turbines.

This is a problem for which there could be a number of solutions. At first sight, the head will suggest two Francis turbines.

$$\text{Power} = 15 \times 10^3 \times 9.81 \times 115 = 15230 \times 10^3 \text{ W.}$$

In order to calculate the specific speed, the working speed of the turbine is required. Let us try 250 rpm (for 50 cycle operation, 12 pairs of pole generator)

$$N_s = \frac{250}{60} \frac{\sqrt{15230 \times 10^3 / 2}}{115^{1.25}} = 30.53$$

This is not a suitable range for Francis turbine. A higher speed of operation say 500 rpm will give  $N_s \approx 60$ . Which is for a narrow rotor, which may not be suitable.

Let us try impulse turbine : operating at 125 rpm.

$$N_s = 15.26, \text{ A single nozzle unit can be selected.}$$

Diameter : Assuming speed ratio of 0.46

$$u = 0.46 \sqrt{2 \times 9.81 \times 115} = 21.85 \text{ m/s}$$

$$\therefore D = \frac{21.85 \times 60}{\pi \times 125} = 3.34 \text{ m}$$

Doubling the speed will reduce the diameter but  $N_s$  also will be doubled and twin nozzle unit may have to be chosen.

**Problem 14.4** A turbine operates at 500 rpm at a head of 550 m. A jet of 20 cm is used. Determine the specific speed of the machine. Assume  $C_v = 0.97$  and efficiency is 88%. If  $\phi = 0.46$  determine the pitch diameter of the runner.

$$\text{Power} = \eta \dot{m} g H = \eta \cdot \frac{\pi D_j^2}{4} \times V_j g H \times \rho$$

$$V_j = 0.97 \sqrt{2gH}$$

$$\begin{aligned} \therefore \text{Power} &= 0.85 \times \frac{\pi \times 0.2^2}{4} \times 1000 \times 0.97 \sqrt{2 \times 9.81 \times 550} \times 9.81 \times 550/1000 \\ &= 14517.9 \text{ kW} = 14.518 \times 10^6 \text{ W} \end{aligned}$$

$$N_s = \frac{500}{60} \frac{\sqrt{145178 \times 10^6}}{550^{5/4}} = 11.92$$

Dimensionless specific speed is = 0.022

A single jet pelton turbine is suitable

$$V_j = 0.97 \sqrt{2 \times 9.81 \times 550}, u = 0.46 V_j$$

$$u = 0.46 \times 0.97 \sqrt{2 \times 9.81 \times 550} = 46.35 \text{ m/s}$$

$$u = \frac{\pi DN}{60}, D = \frac{60 u}{\pi N} = \frac{60 \times 46.35}{\pi \times 500} = 1.77 \text{ m}$$

**Problem 14.5** At a location for a hydroelectric plant, the head available (net) was 335 m. The power availability with an overall efficiency of 86% was 15500 kW. The unit is proposed to run at 500 rpm. Assume  $C_v = 0.98$ ,  $\phi = 0.46$ , Blade velocity coefficient is 0.9. If the bucket outlet angle proposed is  $165^\circ$  **check for the validity of the assumed efficiency**

First flow rate is calculated

$$Q = \frac{15500000}{0.86 \times 1000 \times 9.81 \times 335} = 5.484 \text{ m}^3/\text{s}$$

Jet velocity is next calculated

$$V_j = 0.98 \sqrt{2 \times 9.81 \times 335} = 79.45 \text{ m/s}$$

$$\text{Blade velocity } u = 0.46 \times 79.45 = 36.55 \text{ m/s}$$

$$\text{Runner diameter } D = \frac{36.55 \times 60}{\pi \times 500} = 1.4 \text{ m}$$

Jet diameter assuming single jet,

$$d = \left( \frac{Q \times 4}{\pi V_j} \right)^{0.5} = \left( \frac{5.484 \times 4}{\pi \times 79.45} \right)^{0.5} = 0.296 \text{ m}$$

$$\frac{D}{d} = \frac{1.4}{0.296} = 4.72, \text{ not suitable should be at least } 10.$$

Assume 4 jets, then

$$d = \left( \frac{5.484 \times 4}{4 \times \pi \times 79.45} \right)^{0.5} = 0.1482 \text{ m}, \frac{D}{d} = 9.5$$

may be suggested

$$\text{Per jet, } N_s = \frac{500}{60} \frac{\sqrt{15500000 / 4}}{335^{5/4}} = 11.44$$

Dimensionless  $N_s = 0.0208 \therefore$  acceptable

Such units are in operation in Himachal Pradesh.

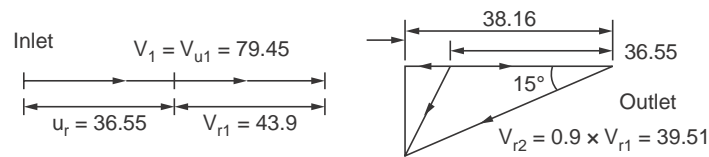

Figure P. 14.5

The velocity diagrams are given above

$$V_{u1} = 79.45, V_{u2} = 38.16 - 36.55 = 1.61 \text{ m/s}$$

$$\therefore W/\text{kg} = 36.55(79.45 + 1.61) = 2962.9 \text{ Nm/kg}$$

$$\eta_H = 2962.9 (9.81 \times 335) = \mathbf{0.9 \text{ or } 90\%}$$

**Assumed value is lower as it should be because, overall efficiency < hydraulic efficiency.**

**Problem 14.6.** A Pelton turbine running at 720 rpm uses 300 kg of water per second. If the head available is 425 m **determine the hydraulic efficiency.** The bucket deflects the jet by 165°. Also **find the diameter of the runner and jet.** Assume  $C_v = 0.97$  and  $\phi = 0.46$ , Blade velocity coefficient is 0.9.

The velocity diagram is shown in figure

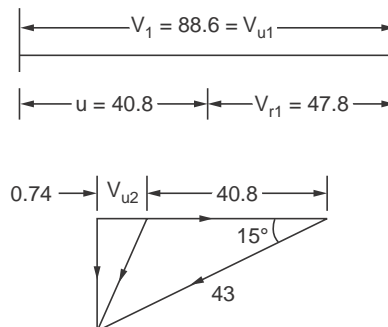

Figure P. 14.6

$$V_j = C_v \sqrt{2gH} = 0.97 \sqrt{2 \times 9.81 \times 425} = 88.6 \text{ m/s}$$

$$u = 0.46 \times 88.6 = 40.8 \text{ m/s}$$

$$V_{r1} = 88.6 - 40.8 = 47.8 \text{ m/s}$$

$$V_{r2} = 0.9 \times 47.8 = 43 \text{ m/s}$$

$$V_{u1} = 88.6 \text{ m/s}$$

$$V_{u2} = 43 \cos 15 - 40.8 = 0.74 \text{ m/s}$$

$$\text{Power} = 300 \times 40.8 (88.6 + 0.74)/1000 = \mathbf{1093.5 \text{ kW}}$$

$$\text{Hydraulic efficiency} = \frac{1093.5 \times 10^3 \times 2}{300 \times 88.6^2} = 0.9286 = \mathbf{92.86\%}$$

$$D = \frac{u \times 60}{\pi N} = \frac{40.8 \times 60}{\pi \times 720} = \mathbf{1.082 \text{ m}}$$

$$d = \left( \frac{4Q}{\pi V_1} \right)^{0.5} = \left( \frac{4 \times 0.3}{\pi \times 88.6} \right)^{0.5} = \mathbf{0.06565 \text{ m}}$$

$$\frac{D}{d} = \frac{1.082}{0.06565} = 16.5$$

$$\text{Overall efficiency} = \frac{1093.5 \times 10^3}{300 \times 9.81 \times 425} = 0.8743 \text{ or } 87.43\%$$

$$N_s = \frac{720}{60} \cdot \frac{\sqrt{1093.5 \times 10^3}}{425^{5/4}} = 3.79$$

**Problem 14.7** The jet velocity in a pelton turbine is 65 m/s. The peripheral velocity of the runner is 25 m/s. The jet is deflected by 160° by the bucket. **Determine the power developed and hydraulic efficiency** of the turbine for a flow rate of 0.9 m<sup>3</sup>/s. The blade friction coefficient is 0.9.

$$V_1 = V_{u1} = 65 \text{ m/s}$$

$$u = 25 \text{ m/s}$$

$$V_{r1} = 65 - 25 = 40 \text{ m/s}$$

$$V_{r2} = 0.9 \times V_{r1} = 36 \text{ m/s}$$

As  $36 \cos 20 = 33.82 < 25$  the shape of the exit triangle is as in figure.

$$\begin{aligned} V_{u2} &= 36 \cos 20 - 25 \\ &= 33.83 - 25 = 8.83 \text{ m/s} \end{aligned}$$

In the opposite direction of  $V_{u1}$  hence addition

$$P = 900 \times 25 (65 + 8.83) = \mathbf{1.661 \times 10^6 \text{ W}}$$

$$\eta_H = \frac{1.661 \times 10^6 \times 2}{900 \times 65^2} = \mathbf{87.37\%}$$

$$\text{Exit loss} = m \frac{V_2^2}{2}$$

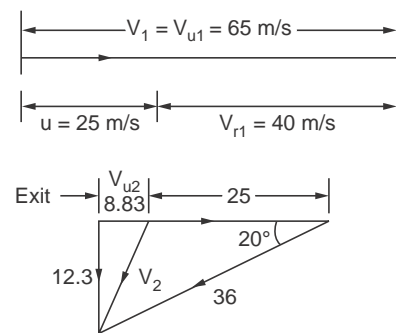

Figure P. 14.7

$$V_2^2 = 36^2 + 25^2 - 2 \times 36 \times 25 \times \cos 20 = 229.55$$

$$\therefore \text{Exit loss of power} = \frac{900 \times 229.35}{2} = 103.3 \times 10^3 \text{ W}$$

**Problem 14.8.** A Pelton turbine is to produce 15 MW under a head of 480 m when running at 500 rpm. If  $D/d = 10$ , **determine the number of jets required.**

$$\text{Assume } \eta_0 = 85\%, C_v = 0.97, \phi = 0.46$$

$$Q = \frac{15 \times 10^6}{0.85 \times 1000 \times 9.81 \times 480} = 3.75 \text{ m}^3/\text{s}$$

$$V_j = 0.97 \sqrt{2 \times 9.81 \times 480} = 94.13 \text{ m/s}$$

$$u = 0.46 \times 94.13 = 43.3 \text{ m/s}$$

$$D = \frac{43.3 \times 60}{\pi \times 500} = 1.65 \text{ m.}$$

$$\therefore d = 0.165 \text{ m}$$

$$\text{Volume flow in a jet} = \frac{\pi \times 0.165^2}{4} \times 94.13 = 2.01 \text{ m}^3/\text{s}$$

Total required = 3.75.  $\therefore$  **Two jets will be sufficient.**

The new diameter of the jets

$$d' = \left( \frac{4 \times 3.75}{2 \times \pi \times 94.13} \right)^{0.5} = 0.1593 \text{ m}$$

$$N_s = \frac{500}{60} \cdot \frac{\sqrt{15 \times 10^6}}{480^{5/4}} = 14.37$$

**Problem 14.9.** The head available at a location was 1500 m. It is proposed to use a generator to run at 750 rpm. The power available is estimated at 20,000 kW. Investigate whether a single jet unit will be suitable. Estimate the number of jets and their diameter. **Determine the mean diameter of the runner and the number of buckets.**

The specific speed is calculated to determine the number of jets.

$$N_s = \frac{750}{60} \cdot \frac{\sqrt{20,000,000}}{1500^{5/4}} = 5.99$$

So a single jet unit will be suitable.

In order to determine the jet diameter, flow rate is to be calculated. The value of overall efficiency is necessary for the determination. It is assumed as 0.87

$$20,000,000 = 0.87 \times Q \times 1000 \times 9.81 \times 1500$$

$$\therefore Q = 1.56225 \text{ m}^3/\text{s}$$



To determine the jet velocity, the value of  $C_v$  is required. It is assumed as 0.97

$$V = 0.97\sqrt{2 \times 9.81 \times 1500} = 166.4 \text{ m/s}$$

$$\therefore 1.56225 = \frac{\pi d^2}{4} \times 166.4. \text{ Solving, } d = 0.1093 \text{ m}$$

In order to determine the runner diameter, the blade velocity is to be calculated. The value of  $\phi$  is assumed as 0.46.

$$\therefore u = 166.4 \times 0.46 \text{ m/s}$$

$$\frac{\pi DN}{60} = u,$$

$$\therefore \frac{166.4 \times 0.46 \times 60}{\pi \times 750} = D \quad \therefore D = 1.95 \text{ m}$$

$$\begin{aligned} \text{The number of buckets} &= Z \cdot \frac{D}{2d} + 15 = \frac{1.95}{2 \times 0.1093} + 15 \\ &= 8.9 + 15 \simeq \mathbf{24 \text{ numbers.}} \end{aligned}$$

**Problem 14.10.** *At a location selected to install a hydro electric plant, the head is estimated as 550 m. The flow rate was determined as 20 m<sup>3</sup>/s. The plant is located at a distance of 2 m from the entry to the penstock pipes along the pipes. Two pipes of 2 m diameter are proposed with a friction factor of 0.029. Additional losses amount to about 1/4th of frictional loss. Assuming an overall efficiency of 87%, **determine how many single jet unit running at 300 rpm will be required.***

The specific speed is to be determined first.

$$\text{Net head} = \text{Head available} - \text{loss in head.}$$

$$\text{Frictional loss} = f L V_p^2 / 2g D.$$

$$V_p \times A_p \times \text{number of pipes} = Q = 20 \text{ m}^3/\text{s}$$

$$\therefore V_p = 20 / \left( \frac{\pi 2^2}{4} \times 2 \right) = 3.183 \text{ m/s}$$

$$L = 2000 \text{ m, } D = 2 \text{ m, } f = 0.029$$

$$\therefore h_f = 0.029 \times 2000 \times 3.183^2 / 2 \times 9.81 \times 2 = 14.98 \text{ m.}$$

$$\text{Total loss of head} = \frac{5}{4} \times 14.8 = 18.72 \text{ m}$$

$$\therefore \text{Net head} = 550 - 18.72 = 531.28 \text{ m}$$

$$\begin{aligned} \text{Power} &= \eta \times Q \times \rho \times g \times H = 0.87 \times 20 \times 1000 \times 9.81 \times 531.28 \\ &= 90.6863 \times 10^6 \text{ W} \end{aligned}$$

$$N_s = \frac{300}{60} \cdot \frac{\sqrt{90.6863 \times 10^6}}{531.28^{5/4}} = 18.667$$

Dimensionless specific speed = 0.034

**This is within the range for a single jet unit.** Discussion of other consideration follow.

**Discussions about suitability of single jet unit.**

$$V_j = C_v \sqrt{2gH} = 0.98 \times \sqrt{2 \times 9.81 \times 531.28} \\ = 100.05 \text{ m/s}$$

$$\frac{\pi d^2}{4} \times V_j = Q \quad \therefore d = \left( \frac{4Q}{\pi V_j} \right)^{0.5}$$

$$\text{Jet diameter, } d = \left( \frac{4 \times 20}{\pi \times 100.05} \right)^{0.5} = 0.5 \text{ m (fairly high)}$$

$$\frac{\pi DN}{60} = 0.46 \times 100.05, \quad \therefore D = \frac{0.46 \times 100.05 \times 60}{300 \pi} = 2.93 \text{ m}$$

$$\text{Jet speed ratio} = \frac{2.95}{0.5} = 6 \text{ too low.}$$

Consider a twin jet unit in which case,  $d = 0.35$  m and Jet speed ratio : 8.3. low side.

**If three jets are suggested, then,  $d = 0.29$**

**Jet speed ratio is about 10. Suitable**

$$\text{In this case} \quad N_s = \frac{300}{60} \cdot \frac{\sqrt{90.6863 \times 10^6 / 3}}{531.28^{5/4}}$$

$$= 10.77, \text{ Dimensionless value} = 0.018$$

**Hence a three jet unit can be suggested.**

**Alternate will be three single jet units.**

**Problem 14.11.** *The following data refers to a Pelton turbine. It drives a 15 MW generator. The effective head is 310 m. The generator and turbine efficiencies are 95% and 86% respectively. The speed ratio is 0.46. Jet ratio is 12. Nozzle velocity coefficient is 0.98. **Determine the jet and runner diameters, the speed and specific speed of the runner.***

From the power and efficiencies the flow rate is determined

$$\eta_T \eta_g Q \rho gH = 15 \times 10^6$$

$$\therefore Q = \frac{15 \times 10^6}{0.95 \times 0.86 \times 1000 \times 9.81 \times 310} = 6.0372 \text{ m}^3/\text{s}$$

The velocity of the jet is determined from the head and  $C_v$

$$V_j = 0.98 \sqrt{2 \times 9.81 \times 310} = 76.43 \text{ m/s}$$

Runner tangential velocity is

$$u = 0.46 \times 76.43 = 35.16 \text{ m/s}$$

Jet diameter is found from flow rate and jet velocity.

$$\frac{\pi d^2}{4} \times V_j = Q, d = \left[ \frac{6.0372 \times 4}{\pi \times 76.43} \right]^{0.5} = \mathbf{0.3171 \text{ m}}$$

Jet speed ratio is  $\frac{D}{d} = 12, \therefore D = 12 \times 0.3171 = 3.8 \text{ m}$

The turbine rotor speed is determined from the tangential velocity

$$\frac{\pi DN}{60} = u,$$

$$N = \frac{u \times 60}{\pi D} = 35.16 \times 60 / \pi \times 3.8 = \mathbf{176.71 \text{ rpm}}$$

$$N_s = \frac{176.61}{60} \cdot \frac{\sqrt{15 \times 10^6}}{310^{5/4}} = \mathbf{8.764}$$

**Problem 14.12.** Show that for the following constants, the dimensionless specific speed is  $0.2096 \frac{d}{D}$ ,  $\phi = 0.48$ ,  $\eta_o = 90\%$ ,  $C_v = 0.98$

$$N_s = \frac{N \sqrt{P}}{\rho^{1/2} (gH)^{5/4}}, \text{ where } N \text{ is rps.}$$

$$Q = \frac{\pi d^2}{4} \times V_j = \frac{\pi d^2}{4} \times 0.98 [2gH]^{1/2}$$

$$= 3.4093 d^2 H^{1/2}$$

$$P = \eta_o \times \rho g Q H = 0.9 \times 1000 \times 9.81 \times 3.4093 d^2 H^{1/2} \times H$$

$$= 30100.73 d^2 H^{1.5}$$

$$N = \frac{u}{\pi d}, u = 0.48 V_j = 0.48 \times 0.98 \sqrt{2g} H^{1/2} = 2.0836 H^{1/2}$$

$$\therefore N = 0.6632 H^{1/2} D^{-1}$$

$$\therefore N_s = \frac{0.6632 H^{1/2}}{D} [30100.73 d^2 H^{1.5}]^{1/2} / 1000^{1/2} g^{1.25} H^{1.25}$$

$$= 115.068 \frac{dH^{1.25}}{D} / 549 H^{1.25} = \mathbf{0.2096 \frac{d}{D}}$$

**Problem 14.13.** The outer diameter of a Francis runner is 1.4 m. The flow velocity at inlet is 9.5 m/s. The absolute velocity at the exit is 7 m/s. The speed of operation is 430 rpm. The power developed is 12.25 MW, with a flow rate of 12 m<sup>3</sup>/s. Total head is 115 m. For shockless entry determine the angle of the inlet guide vane. Also find the absolute velocity at entrance, the

runner blade angle at inlet and the loss of head in the unit. Assume zero whirl at exit. Also fluid the specific speed.

$$\text{The runner speed } u_1 = \frac{\pi D N}{60} = \frac{\pi \times 430 \times 14}{60} = 31.52 \text{ m/s}$$

$$\text{As } V_{u2} = 0,$$

$$\begin{aligned} \text{Power developed} &= \dot{m} V_{u1} u_1 \\ 12.25 \times 10^6 &= 12 \times 10^3 \times V_{u1} \times 31.52 \end{aligned}$$

$$\text{Solving } V_{u1} = \mathbf{32.39 \text{ m/s}}$$

$$V_{u1} > u_1$$

∴ The shape of the inlet

Velocity triangle is as given. Guide blade angle  $\alpha_1$ ,

$$\tan \alpha_1 = \frac{9.5}{32.39} \quad \therefore \alpha_1 = \mathbf{16.35^\circ}$$

$$V_1 = (V_{f1}^2 + V_{u1}^2)^{0.5} = [9.5^2 + 32.39^2]^{0.5} = \mathbf{33.75 \text{ m/s}}$$

Blade inlet angle  $\beta_1$

$$\tan \beta_1 = 9.5 / (32.39 - 31.52)$$

$$\therefore \beta_1 = \mathbf{84.77^\circ}$$

Total head = 115 m. **head equal for Euler work** =  $\dot{m} V_{u1} u_1 / g$

$$= \frac{32.39 \times 31.52}{9.81} = \mathbf{104.07 \text{ m}}$$

Head loss in the absolute velocity at exit

$$= \frac{7^2}{2 \times 9.81} = \mathbf{2.5 \text{ m}}$$

$$\therefore \text{Loss of head} = 115 - 104.07 - 2.5 = \mathbf{8.43 \text{ m}}$$

$$N_s = \frac{430}{60} \cdot \frac{\sqrt{12.25 \times 10^6}}{115^{1.25}} = \mathbf{223.12}$$

As the inner diameter is not known blade angle at outlet cannot be determined.

**Problem 14.14.** A Francis turbine developing 16120 kW under an a head of 260 m runs at 600 rpm. The runner outside diameter is 1500 mm and the width is 135 mm. The flow rate is  $7 \text{ m}^3/\text{s}$ . The exit velocity at the draft tube outlet is 16 m/s. Assuming zero whirl velocity at exit and neglecting blade thickness determine the overall and hydraulic efficiency and rotor blade angle at inlet. Also find the guide vane outlet angle :

$$\text{Overall efficiency} = \frac{\text{Power developed}}{\text{Hydraulic power}} = \frac{16120 \times 10^3}{7 \times 1000 \times 9.81 \times 260}$$

$$\eta_o = \mathbf{0.9029 \text{ or } 90.29\%}$$

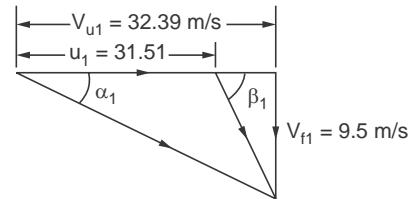

Figure P. 14.13

Assuming no friction and other losses,

$$\text{Hydraulic efficiency} = \left( H - \frac{V_2^2}{2g} \right) / H$$

where  $V_2$  is the exit velocity into the tailrace

$$\begin{aligned} \eta_H &= (260 - (16^2/2 \times 9.81)) / 260 \\ &= \mathbf{0.9498 \text{ or } 94.98\%} \end{aligned}$$

As  $V_{u2}$  is assumed to be zero,

$$V_{u1} = \eta_H (gH) / u_1$$

$$u_1 = \pi DN / 60 = \frac{\pi \times 1.5 \times 600}{60} = \mathbf{47.12 \text{ m/s}}$$

$$\therefore V_{u1} = 0.9498 \times 9.81 \times 260 / 47.12 = \mathbf{51.4 \text{ m/s}}$$

$$V_{u1} > u$$

$\therefore$  The shape of the velocity triangle is as given.  $\beta$  is the angle taken with the direction of blade velocity.

$$V_{f1} = \frac{Q}{\pi D_1 b_1} = \frac{7}{\pi \times 1.5 \times 0.135} = \mathbf{11 \text{ m/s}}$$

$$\tan \alpha_1 = 11 / 51.4$$

$$\therefore \alpha_1 = \mathbf{12.08^\circ}$$

$$\tan \beta_1 = 11 / (51.4 - 47.12)$$

$$\therefore \beta_1 = \mathbf{68.74^\circ}$$

The specific speed of the unit

$$= \frac{600}{60} \frac{\sqrt{16120000}}{260^{1.25}} = \mathbf{38.46}$$

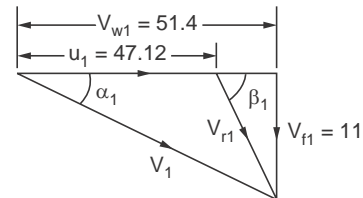

Figure P. 14.14

It is on the lower side.

**Problem 14.15.** A small Francis turbine develops 2555 kW working under a head of 25 m. The overall efficiency is 0.9. The diameter and width at inlet are 1310 mm and 380 mm. At the outlet these are 1100 mm and 730 mm. The runner blade angle at inlet is  $135^\circ$  along the direction of the blade velocity. The whirl is zero at exit. Determine the runner speed, whirl velocity at inlet, the guide blade outlet angle and the flow velocity at outlet. Assume  $\eta_v = 0.98$ ,  $\eta_m = 0.97$ .

$$\begin{aligned} \text{The flow rate} \quad Q &= P / \eta_o gH \\ &= 2555 \times 10^3 / 0.9 \times 9.81 \times 25 = \mathbf{11.58 \text{ m}^3/\text{s}} \end{aligned}$$

Hydraulic efficiency = Overall efficiency / (Mechanical efficiency  $\times$  Volumetric efficiency)

$$\therefore \eta_H = 0.9 / 0.98 \times 0.97 = \mathbf{0.9468}$$

$$= u_1 V_{u1} / gH$$

$$\therefore u_1 V_{u1} = 0.9468 \times 9.81 \times 25 = \mathbf{232.2 \text{ m}}$$

The flow velocity at inlet

$$V_{f1} = 11.55/\pi \times 1.31 \times 0.38 \\ = \mathbf{7.385 \text{ m/s}}$$

$$\tan (180 - 135) = V_{f1} / (u_1 - V_{u1})$$

$$\therefore u_1 - V_{u1} = 7.385 \times \tan (180 - 135) \\ = 7.385$$

$$u_1 (u_1 - 7.385) = 232.2$$

$$u_1^2 - 7.385 u_1 - 232.2 = 0$$

$$\therefore \mathbf{u_1 = 19.37 \text{ m/s}, V_{u1} = 11.99 \text{ m/s}}$$

$$u_1 = \frac{\pi DN}{60}, N = 4 \times 60/\pi D = 19.37 \times 60 / \pi \times 1.31 = \mathbf{282.4 \text{ rpm}}$$

$$\tan \alpha_1 = 7.385 / 11.9 \quad \therefore \mathbf{\alpha_1 = 31.63^\circ}$$

$$V_{f2} = 11.58/\pi \times 1.1 \times 0.73 = \mathbf{4.59 \text{ m/s} = V_2}$$

Blade velocity at outlet

$$u_2 = \frac{\pi D_2 N}{60} = \frac{\pi \times 1.1 \times 282.4}{60} = \mathbf{16.26 \text{ m/s}}$$

The exit triangle is right angled

$$\tan (180 - \beta_2) = \frac{4.59}{16.26}$$

$$\therefore 180 - \beta_2 = 15.76^\circ, \mathbf{\beta_2 = 164.24^\circ}$$

$$\text{Specific speed} = \frac{N \sqrt{P}}{H^{5/4}}$$

$$N_s = \frac{282.4 \sqrt{2555000}}{60 \times 25^{1.25}} = \mathbf{134.58.}$$

**Problem 14.16.** A Francis turbine works under a head of 120 m. The outer diameter and width are 2 m and 0.16 m. The inner diameter and width are 1.2 m and 0.27 m. The flow velocity at inlet is 8.1 m/s. The whirl velocity at outlet is zero. The outlet blade angle is 16°. Assume  $\eta_H = 90\%$ . Determine, power, speed and blade angle at inlet and guide blade angle.

The outlet velocity diagram is a right angled triangle as shown

$$V_{f2} = V_{f1} \times D_1 b_1 / D_2 b_2 \\ = 8.1 \times 2 \times 0.16 / 1.2 \times 0.27 = 8 \text{ m/s}$$

$$\therefore u_2 = 8/\tan 16 = \mathbf{27.9 \text{ m/s}}$$

$$\frac{\pi D_2 N}{60} = u_2, \quad \frac{\pi \times 1.2 \times N}{60} = 27.9.$$

Solving  $N = 444 \text{ rpm}$

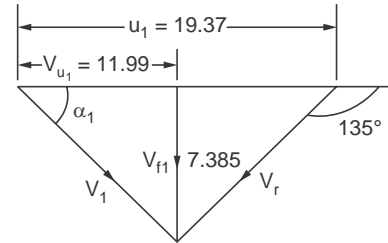

Figure P. 14.15

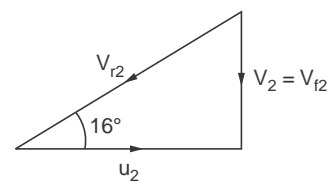

Figure P. 14.16

$$u_1 = \frac{\pi D_1 N}{60} = \frac{\pi \times 2 \times 266.4}{60} = 46.5 \text{ m/s}$$

$$\eta_H = \frac{u_1 V_{u1}}{g H}, V_{u1} = \frac{0.9 \times 9.81 \times 120}{46.5} = 22.8 \text{ m/s}$$

$$u_1 > V_{u1}.$$

The shape of the inlet triangle is shown.

$$\tan \alpha_1 = \frac{V_{f1}}{V_{u1}} = \frac{8.1}{22.8}$$

$$\therefore \alpha_1 = 19.55^\circ$$

$$\tan (180 - \beta_1) = \frac{V_{f1}}{u_1 - V_{u1}} = \frac{8.1}{46.5 - 22.8}$$

$$\therefore \beta_1 = 161^\circ$$

$$\text{Flow rate} = \pi D_1 b_1 V_{f1} = \pi \times 2 \times 0.16 \times 8.1 = 8.143 \text{ m}^3/\text{s}$$

$$\text{Power} = 0.9 \times 120 \times 9.81 \times 8.143 \times 10^3 / 10^3 = 8627 \text{ kW}$$

$$N_s = \frac{444}{60} \frac{\sqrt{8627 \times 10^2}}{120^{5/4}} = 54.72$$

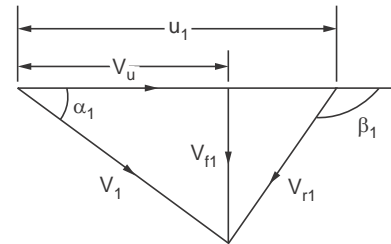

Figure P. 14.16

**Problem.14.17** An inward flow reaction turbine of the Francis type operates with a flow rate of  $1.67 \text{ m}^3/\text{s}$  runs at 416 rpm. The available head is 81 m. The blade inlet angle is  $120^\circ$  with the direction of wheel velocity. The flow ratio is 0.2. Hydraulic efficiency is 92%. Determine runner diameter, the power developed and the speed ratio

$$\text{Power developed} = 0.92 \times 81 \times 9.81 \times 1.67 \times 10^3 / 10^3$$

$$P = 1220.8 \text{ KW}$$

$$u_1 V_{u1} = 1220.8 \times 10^3 / 1.67 \times 10^3 = 731.04 \text{ m}^2/\text{s}^2$$

$$\text{Flow ratio} = 0.2 = \frac{V_{f1}}{\sqrt{2gH}}, \therefore V_{f1} = 0.2 \sqrt{2 \times 9.81 \times 81} = 7.973 \text{ m/s}$$

The shape of the velocity triangle is as shown.  $\beta_1 > 90^\circ$

$$V_{u1} = u_1 - \frac{7.973}{\tan 60} = u_1 - 4.6$$

$$u_1 V_{u1} = 731.04 = u_1 (u_1 - 4.6)$$

$$\text{or } u_1^2 - 4.6 u_1 - 731.04 = 0. \text{ Solving, } u_1 = 29.44 \text{ m/s}$$

$$\therefore V_{u1} = 29.44 - 4.6 = 24.84 \text{ m/s}$$

$$\text{Speed ratio } \phi = \frac{u_1}{V_1}, V_1 = (24.84^2 + 7.973^2)^{1/2} = 26.09 \text{ m/s}$$

$$\therefore \phi = \frac{29.44}{26.09} = 1.128$$

$$\frac{\pi D_1 N}{60} = 29.44$$

$$\therefore D = 1.35 \text{ m}$$

$$N_s = \frac{416}{60} \cdot \frac{\sqrt{1220 \times 10^3}}{81^{1.25}} = 31.53$$

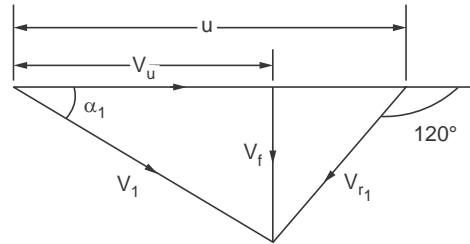

Figure P. 14.17

**Problem 14.18** Determine the diameters and blade angles of a Francis turbine running at 500 rpm under a head of 120 m and delivering 3 MW. Assume flow ratio as 0.14 and  $D_2 = 0.5 D_1$  and  $b_1 = 0.1 D_1$ . The hydraulic efficiency is 90% and the overall efficiency is 84%.

$$V_{f1} = 0.14 \sqrt{2gH} = 0.14 \sqrt{2 \times 9.81 \times 120} = 6.79 \text{ m/s}$$

From the overall efficiency and power delivered

$$Q = \frac{3 \times 10^6}{10^3 \times 9.81 \times 120 \times 0.84} = 3.034 \text{ m}^3/\text{s}$$

$$Q = \pi D_1 b_1 V_{f1} = \pi D_1 \times 0.1 D_1 \times 6.79$$

Solving

$$D_1 = 1.193 \text{ m}, D_2 = 0.5965 \text{ m}$$

$$b_1 = 0.1193 \text{ m}, b_2 = 0.2386 \text{ m}$$

$$u_1 = \frac{\pi D_1 N}{60} = \frac{\pi \times 1.193 \times 500}{60} = 31.23 \text{ m/s}$$

$$\therefore u_2 = 15.615 \text{ m/s}$$

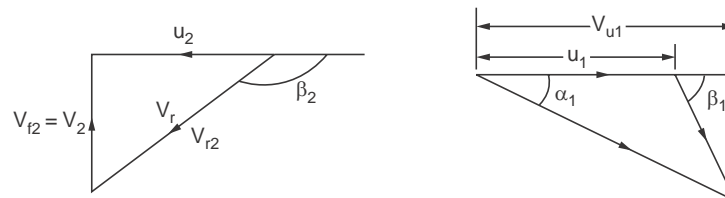

Figure P. 14.18

The outlet triangle is as shown as  $V_{u2} = 0$ , assuming  $V_{f2} = V_{f1}$

$$\tan (180 - \beta_2) = \frac{6.79}{15.615}$$

$$\therefore \text{Solving } \beta_2 = 156.5^\circ (23.5^\circ)$$

To solve inlet angles,  $V_{u1}$  is required

$$0.9 = \frac{u_1 V_{u1}}{gH}$$



$$\therefore V_{u1} = \frac{0.9 \times 9.81 \times 120}{31.23} = 33.93 \text{ m/s}$$

$$V_{u1} > u_1. \quad \therefore \text{The triangle is as shown}$$

$$\tan \alpha_1 = \frac{V_{f1}}{V_{u1}} = \frac{6.79}{33.93} \quad \therefore \alpha_1 = 11.32^\circ$$

$$\tan \beta_2 = \frac{6.79}{33.93 - 31.23} \quad \therefore \beta_1 = 68.3^\circ$$

**Problem 14.19** In an inward flow reaction turbine the working head is 10 m. The guide vane outlet angle is  $20^\circ$ . The blade inlet angle is  $120^\circ$ . **Determine the hydraulic efficiency** assuming zero whirl at exit and constant flow velocity. Assume no losses other than at exit.

The velocity diagram is as shown in figure. As no velocity value

$$V_u = V_1 \cos 20 = 0.9397 V_1 \quad (1)$$

$$V_f = V_1 \sin 20 = 0.3420 V_1 \quad (2)$$

is available, the method adopted is as below.

$$u = V_u + \frac{V_f}{\tan 60} = 0.9397 V_1 + \frac{0.342 V_1}{1.732} = 1.1372 V_1 \quad (3)$$

Work done = headlosses (all expressed as head)

$$\frac{u \cdot V_u}{g} = H - \frac{V_f^2}{2g}$$

$$\frac{1.1372 \times 0.9397}{9.81} \cdot V_1^2 = 10 - \frac{0.342^2 V_1^2}{2 \times 9.81}$$

$$0.10893 V_1^2 + 0.00596 V_1^2 = 10$$

$$\therefore V_1 = \left[ \frac{10}{0.1093 + 0.00596} \right]^{0.5} = 9.33 \text{ m/s}$$

$$\therefore u = 1.1372 \times 9.33 = 10.61 \text{ m/s}$$

$$V_{u1} = 0.9397 \times 9.33 = 8.767 \text{ m/s}$$

$$\eta_H = \frac{10.61 \times 8.767}{9.81 \times 10} = 0.9482 \text{ or } 94.82\%$$

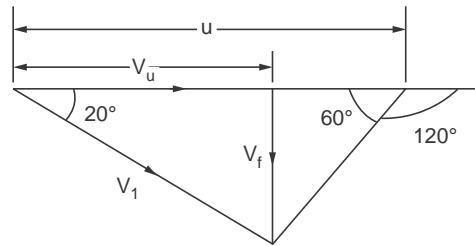

Figure P. 14.18

**Problem 14.20** A Francis turbine delivers 16 MW with an overall efficiency of 85 percent and a hydraulic efficiency of 91 percent, when running at 350 rpm under a head of 100 m. Assume ID = 0.6 OD and width as 0.10 D. The flow ratio is 0.2 and blade blockage is 8 percent of flow area at inlet. Assume constant flow velocity and zero whirl at exit. **Determine the runner diameter, and blade angles.**

$$\text{Overall efficiency} = \frac{\text{Power delivered}}{\rho Q g H} \quad \therefore Q = \frac{\text{Power delivered}}{\rho \eta_0 g H}$$

$$= \frac{16 \times 10^6}{1000 \times 0.85 \times 9.81 \times 100} = 19.1881 \text{ m}^3/\text{s}$$

$$Q = \pi D b V_f (1 - 0.08), \text{ Flow ratio} = \frac{V_f}{\sqrt{2gH}}$$

$$\therefore V_f = \text{flow ratio} \times \sqrt{2gH} = 0.2 \sqrt{2 \times 9.81 \times 100} = 8.86 \text{ m/s}$$

$$\therefore 19.1881 = \pi D \times 0.1 D \times 8.86 \times (1 - 0.08)$$

$$\therefore D^2 = \frac{19.1881}{\pi \times 0.1 \times 8.86 \times 0.92}$$

$$\therefore D = 2.74 \text{ m, } b = 0.274 \text{ m}$$

$$ID = 1.64 \text{ m}$$

$$u_1 = \frac{\pi D_1 N}{60} = \frac{\pi \times 2.74 \times 350}{60} = 50.21 \text{ m/s, } u_2 = 30.13 \text{ m/s}$$

$$\eta_H = \frac{u_1 V_{u1}}{g H}, 0.91 = \frac{50.21 \times V_{u1}}{9.81 \times 100}$$

$$\therefore V_{u1} = 17.78 \text{ m/s}$$

$$V_{u1} < u_1$$

$\therefore$  The velocity diagram is as in figure

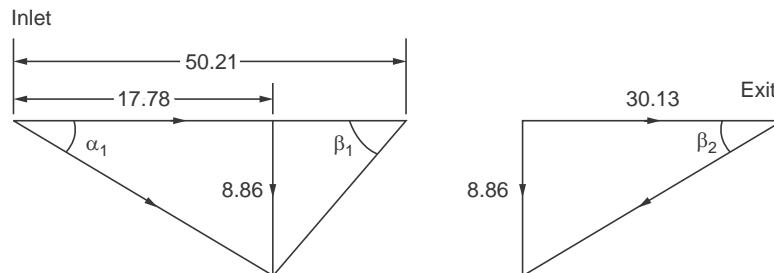

Figure P. 14.20

$$\tan \alpha_1 = \frac{8.86}{17.78}$$

$\therefore$  Guide blade outlet angle is  $26.5^\circ$

$$\tan \beta_1 = \frac{8.86}{50.12 - 17.78}$$

$\therefore \beta_1 = 15.3^\circ$  (as in figure) or  $164.7^\circ$  (along + ve u)

$$\tan \beta_2 = \frac{8.86}{30.13}$$

Outlet angle  $\beta_2 = 16.4^\circ$  (as in figure) or  $163.6^\circ$  (with + ve u direction)

**Problem 14.21** An inward low reaction turbine has a flow velocity of 4 m/s while the peripheral velocity is 35 m/s. The whirl velocity is 26 m/s. There is no whirl at exit. If the hydraulic efficiency is 91% determine the head available. Also find the inlet blade angle and the guide vane outlet angle.

The velocity diagram is as shown

$$\tan \beta_1 = \frac{V_f}{u - V_{u1}} = \frac{4}{35 - 26} = 0.444$$

$\therefore$  Blade angle at inlet,  $\beta_1 = 23.96^\circ$  or **156.04°**.

$$\tan \alpha_1 = \frac{V_f}{Vu_1} = \frac{4}{26} = 0.1538,$$

$\therefore$  **Guide vane outlet angle = 8.75°**

As exit whirl is zero

$$\eta_H = \frac{u_1 V_{u1}}{g H}$$

$$\therefore H = \frac{u_1 V_{u1}}{g \times \eta_H} = \frac{35 \times 26}{9.81 \times 0.91} = \mathbf{101.94 \text{ m}}$$

**Problem 14.22** The diameter and blade angles of a Francis turbine with a specific speed of 95 are to be determined. The power delivered is 45 MW under a head of 180 m. Assume overall efficiency of 85% and hydraulic efficiency of 90%. Also  $b_1 = 0.1 D_1$  and blade thickness occupies 5% of flow area. The constant flow velocity is 15 m/s.

To determine the speed

$$N_s = \frac{N}{60} \cdot \frac{\sqrt{P}}{H^{5/4}}$$

$$\begin{aligned} \therefore N &= 95 \times 60 \times 180^{5/4} / \sqrt{45 \times 10^6} \\ &= \mathbf{560.22}. \text{ Say } 560 \text{ rpm} \end{aligned}$$

not suitable for 50 cycles.

**500 rpm can be adopted** (with 6 pairs of poles), power capacity cannot be changed.

$$N_s = \frac{500}{60} \cdot \frac{\sqrt{45 \times 10^6}}{180^{1.25}} = \mathbf{84.8}. \text{ May be adopted}$$

$$Q = \frac{5 \times 10^6}{0.85 \times 1000 \times 9.81 \times 180} = \mathbf{29.98 \text{ m}^3/\text{s}}$$

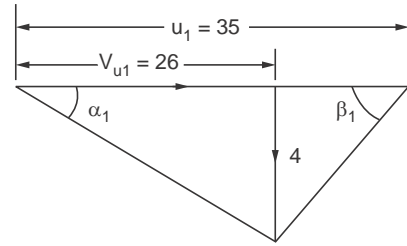

Figure P. 14.21

Solving,

$$Q = \pi D_1 b_1 V_f \times 0.95 = \pi \times D_1 \times 0.1 D_1 \times 15 \times 0.95 = 29.98$$

$$D_1 = 2.59 \text{ m}, D_2 = 1.295 \text{ m}$$

$$b_1 = 0.259 \text{ m}, b_2 = 0.518 \text{ m}$$

$$u_1 = \frac{\pi D_1 N}{60} = \frac{\pi \times 2.59 \times 500}{60} = 67.8 \text{ m/s}$$

$$u_2 = 33.9 \text{ m/s}$$

$$0.9 = \frac{u_1 V_{u1}}{g H}$$

$$\therefore V_{u1} = \frac{0.9 \times 9.81 \times 180}{67.8} = 23.44 \text{ m/s}$$

Velocity triangles are as shown

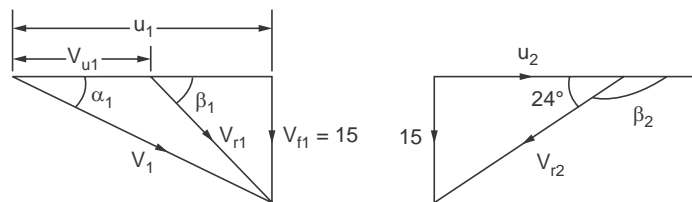

Figure P. 14.22

$$\tan \alpha_1 = 15 / 67.8 \quad \therefore \alpha_1 = 12.48^\circ$$

$$\tan \beta_1 = 15 / (67.8 - 23.44) \quad \therefore \beta_1 = 18.7^\circ$$

$$\tan (180 - \beta_2) = 15 / 33.9 \quad \therefore \beta_2 = 156^\circ (24^\circ)$$

**Problem 14.23.** In a Francis turbine the guide blade angle is  $17^\circ$  and the entry to the runner is in the radial direction. The speed of operation is 400 rpm. The flow velocity remains constant at 10 m/s. The inner diameter is 0.6 of outer diameter. The width at inlet is 0.12 times the diameter. Neglecting losses, determine the head, the diameter and power. Also fluid the angle at blade outlet. The flow area is blocked by vane thickness by 6%.

This is a special case and the inlet velocity triangle is a right angled triangle.

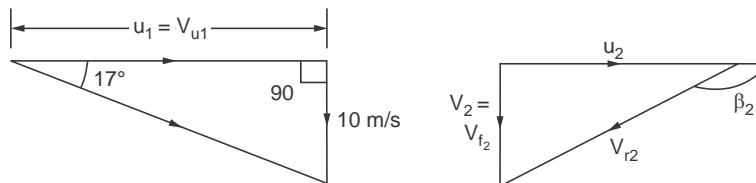

Figure P. 14.23

The inlet velocity diagram is as shown

$$u_1 = \frac{V_{f1}}{\tan \alpha_1} = \frac{10}{\tan 17^\circ} = 32.7 \text{ m/s}$$

$$\mathbf{u}_2 = u_1 \times 0.6 = \mathbf{19.63 \text{ m/s}}$$

$$\mathbf{D}_1 = \frac{60 \times u_1}{\pi \times N} = \frac{60 \times 32.7}{\pi \times 400} = \mathbf{1.56 \text{ m}}, \mathbf{b}_1 = \mathbf{0.1874 \text{ m}}$$

$$\mathbf{D}_2 = \mathbf{0.936 \text{ m}}$$

Neglecting losses head supplied

$$\mathbf{H} = \frac{u_1 V_{u1}}{g} + \frac{V_2^2}{2g} = \frac{32.7^2}{9.81} + \frac{10^2}{2 \times 9.81} = \mathbf{114.1 \text{ m}}$$

$$\mathbf{Q} = \pi D_1 b_1 V_{f1} \times 0.94 = \pi \times 1.56 \times 0.1874 \times 10 \times 0.94 = \mathbf{8.633 \text{ m}^3/\text{s}}$$

$$\therefore \text{Power } \mathbf{P} = \frac{8.633 \times 10^3 \times 32.7^2}{10^3} = \mathbf{9221 \text{ kW}}$$

From the velocity triangle at outlet

$$\tan (180 - \beta_2) = \frac{10}{19.63}$$

$$\therefore \beta_2 = \mathbf{153^\circ}$$

**Problem 14.24.** Show in the case of a  $90^\circ$  inlet Francis turbine, the hydraulic efficiency =  $\frac{2}{2 + \tan^2 \alpha_1}$ .

The velocity diagram is as shown

$$\tan \alpha_1 = \frac{V_{f1}}{u_1} = \frac{V_{f1}}{V_{u1}}$$

$$\therefore u_1 V_{u1} = u_1^2 = \frac{V_{f1}^2}{\tan^2 \alpha_1}$$

Neglecting losses and assuming  $V_{f2} = V_{f1}$

$$\text{Work input} = u_1 V_{u1} + \frac{V_{f1}^2}{2}$$

$$\therefore \eta_H = \frac{V_{f1}^2 / \tan^2 \alpha_1}{\frac{V_{f1}^2}{\tan^2 \alpha_1} + \frac{V_{f1}^2}{2}}$$

Multiplying by 2 and also  $\tan^2 \alpha_1$  both the numerator and denominator

$$\eta_H = \frac{2V_{f1}^2}{2V_{f1}^2 + V_{f1}^2 \tan^2 \alpha_1} = \frac{2}{2 + \tan^2 \alpha_1}.$$

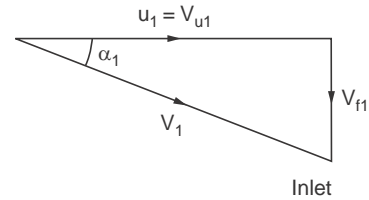

Figure P. 14.24

**Problem 14.25.** The following details are available about a Francis turbine. Diameters are 2.25 m and 1.5 m. Widths are 0.25 m and 0.375 m. The guide blade outlet angle is  $18^\circ$  runner blade angle is  $85^\circ$ . Both angles with the blade velocity direction. Frictional loss is 15% of the pressure head available between the inlet and outlet of the runner is 60 m. Calculate the speed and output of the turbine. Also find the fluid blade outlet angle. Mechanical efficiency is 92%. Blade thickness blocks the flow area by 8%.

In this case as

$$D_1 b_1 = D_2 b_2,$$

$$\therefore V_{f2} = V_2 = V_{f1}$$

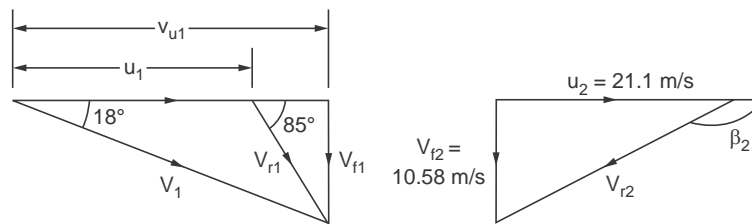

Figure P. 14.25

To determine the work output

$u_1, V_{u1}$  are to be calculated

$$V_{u1} = V_1 \cos 18^\circ = 0.951 V_1 \quad (\text{A})$$

$$V_{f1} = V_1 \sin 18^\circ = 0.309 V_1$$

$$u_1 = V_{u1} - V_{f1} / \tan 85 = 0.951 V_1 - 0.309 V_1 / \tan 85$$

$$= 0.924 V_1$$

$$\therefore u_1 V_{u1} = 0.951 \times 0.924 V_1^2 = 0.8787 V_1^2, \text{ as head} = \frac{0.8787 V_1^2}{g}$$

Considering the runner inlet and outlet

$$h_1 + \frac{V_1^2}{2g} = h_2 + \frac{V_2^2}{2g} + W + h_L$$

$$h_1 - h_2 = 60 \text{ m}, h_L = 0.15 \times 60 = 9 \text{ m}, V_2^2 = V_f^2 = 0.309^2 V_1^2$$

$$V_2^2 = 0.0955 V_1^2$$

$$\therefore h_1 - h_2 - h_L = -\frac{V_1^2}{2g} + \frac{0.0955 V_1^2}{2g} + \frac{0.8787 V_1^2}{g}$$

$$51 = \frac{V_1^2}{g} \left[ -\frac{1}{2} + \frac{0.0955}{2} + 0.8787 \right] = 0.42645 \frac{V_1^2}{g}$$

Solving,

$$V_1 = 34.25 \text{ m/s} \quad \therefore u_1 = 31.65 \text{ m/s}, V_{u1} = 32.57 \text{ m/s}$$

$$V_{f1} = V_{f2} = V_2 = 10.58 \text{ m/s}$$

$$\frac{\pi D_1 N}{60} = 34.25, D_1 = 2.25 \text{ m}, \quad \therefore N = 290.7 \text{ rpm}$$

$$\begin{aligned} \text{Flow rate} &= \pi D_1 b_1 \times (1 - 0.08) V_f \\ &= \pi \times 2.25 \times 0.25 \times 0.92 \times 10.58 \text{ m}^3/\text{s} \\ Q &= 17.2 \text{ m}^3/\text{s} \end{aligned}$$

$$\begin{aligned} \therefore \text{Power developed} &= 17.2 \times 10^3 \times 32.57 \times 31.65/1000 \\ &= 17730 \text{ kW} \end{aligned}$$

$$\text{Power delivered} = P \times \eta_{\text{mech.}} = 16312 \text{ kW}$$

$$u_2 = u_1 \times 1.5 / 2.25 = 34.25 \times 1.5 / 2.25 = 21.1 \text{ m/s}$$

From Exit triangle,  $V_2 = V_{f2} = 10.58 \text{ m/s}$

$$\tan (180 - \beta_2) = (10.58 / 21.1)$$

Solving  $\beta_2 = 153.4^\circ$  (as in figure)

**Problem 14.26.** In a Francis turbine installation the runner inlet is at a mean height of 2 m from tailrace while the outlet is 1.7 m from the tailrace. A draft tube is connected at the outlet. The runner diameter is 1.5 m and runs at 375 rpm. The pressure at runner inlet is 35 m above atmosphere, while the pressure at exit is 2.2 m below the atmosphere. The flow velocity at inlet is 9 m/s. At output it is 7 m/s. Available head is 62 m. Hydraulic efficiency is 90%. Determine the losses before the runner, in the runner and at exit.

Runner outlet velocity

$$u_1 = \frac{\pi D N}{60} = \frac{\pi \times 1.5 \times 375}{60} = 29.45 \text{ m/s}$$

To find  $V_{u1}$ ,

$$0.9 = \frac{29.45 \times V_{u1}}{9.81 \times 62}$$

$$\therefore V_{u1} = 18.59 \text{ m/s}$$

Head loss upto the exit of guide blades or entry to runner. Denoting these locations as 1 and 2.

$$h_1 + \frac{V_1^2}{2g} + Z_o = h_2 + \frac{V_2^2}{2g} + Z_2 + h_{L1}$$

$$\text{LHS} = 62 \text{ m}, h_2 = 35 \text{ m}, Z_2 = 2 \text{ m}$$

$$V_1^2 = (18.59^2 + 9^2) = 426.6 \text{ m}^2/\text{s}^2$$

$$\text{Substituting, } \therefore \frac{V_1^2}{2g} = 21.74 \text{ m}$$

$$62 = 35 + 2 + \frac{426.6}{2 \times 9.81} + h_{L1}$$

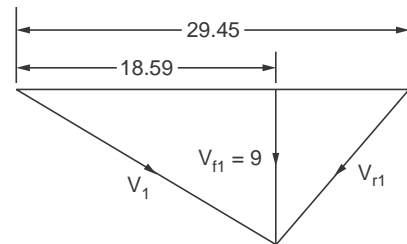

Figure P. 14.26

$$h_{L1} = 62 - 35 - 2 - 21.74 = 3.26 \text{ m}$$

Considering the runner inlet and outlet : Denoting as 1 and 2

$$h_1 + \frac{V_1^2}{2g} + Z_1 = h_2 + Z_2 + W + \frac{V_2^2}{2g} + h_{L2}$$

$$35 + 21.74 + 2 = -2.2 + 1.7 + \frac{29.45 \times 18.59}{9.81} + h_{L2} + \frac{7^2}{2 \times 9.81}$$

$$= -2.2 + 1.7 + 55.81 + 2.5 + h_{L2}$$

$$\therefore h_{L2} = 0.93 \text{ m.}$$

Considering the draft tube

$$\text{Static head available} = 1.7 \text{ m}$$

$$\text{Kinetic head available} = 2.5 \text{ m}$$

$$\text{Total} = 4.2 \text{ m}$$

$$\text{But actual head at turbine exit} = 2.2 \text{ m}$$

$$\therefore \text{Loss, } h_{L3} = 2 \text{ m}$$

$$\text{Total loss} = 3.26 + 0.93 + 2 = 6.19 \text{ m in } 6.2 \text{ m}$$

**10% of the total head.** as hydraulic efficiency is 90%.

**Problem 14.27.** A Kaplan turbine plant develops 3000 kW under a head of 10 m. While running at 62.5 rpm. The discharge is 350 m<sup>3</sup>/s. The tip diameter of the runner is 7.5 m and the hub to tip ratio is 0.43. Calculate the specific speed, turbine efficiency, the speed ratio and flow ratio.

Speed ratio is based on tip speed.

$$\text{Hub diameter} = 0.43 \times 7.5 = 3.225 \text{ m}$$

$$\text{Turbine efficiency} = P / \rho Q H g$$

$$= \frac{30000 \times 10^3}{1000 \times 350 \times 10 \times 9.81} = 0.8737 \text{ or } 87.37\%$$

$$\text{Specific speed} = \frac{60}{60} \cdot \frac{\sqrt{30,000 \times 10^3}}{10^{1.25}} = 308$$

$$\text{Runner tip speed} = \frac{\pi \times 7.5 \times 60}{60} = 23.56 \text{ m/s}$$

$$\therefore \text{Speed ratio} = 23.56 / \sqrt{2 \times 9.81 \times 10} = 1.68$$

$$\text{Flow velocity} = \frac{350 \times 4}{\pi (7.5^2 - 3.225^2)} = 9.72 \text{ m/s}$$

$$\therefore \text{Flow ratio} = 9.72 / \sqrt{2 \times 9.81 \times 10} = 0.69.$$



**Problem 14.28** A Kaplan turbine delivering 40 MW works under a head of 35 m and runs at 167 rpm. The hub diameter is 2.5 m and runner tip diameter is 5 m. The overall efficiency is 87%. **Determine the blade angles at the hub and tip** and also at a diameter of 3.75 m. **Also find the speed ratio and flow ratio based on tip velocity.** Assume  $\eta_H = 90\%$ .

$$\text{Flow rate } Q = \frac{40 \times 10^6}{10^3 \times 9.81 \times 35 \times 0.87} = 133.9 \text{ m}^3/\text{s}$$

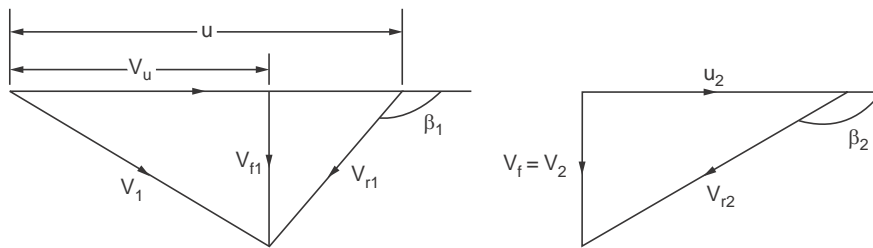

Figure P. 14.28

Assuming no obstruction by blades,

$$V_f = \frac{133.9 \times 4}{\pi (5^2 - 2.5^2)} = 9.09 \text{ m/s}$$

$$\text{Blade tip velocity} = \frac{\pi \times 5 \times 167}{60} = 43.72 \text{ m/s}$$

$$\text{Hub velocity} = 43.72/2 = 21.86 \text{ m/s}$$

$$\text{Velocity at 3.75 m,} = \frac{\pi \times 3.75 \times 167}{60} = 32.79 \text{ m/s}$$

$$u_1 V_{u1} = 0.9 \times 9.81 \times 35 = 309 \text{ m}^2/\text{s}^2 \\ = \text{Constant}$$

$$\therefore V_{u1} \text{ at tip} = 309 / 43.72 = 7.07 \text{ m/s}$$

$$V_{u1} \text{ at hub} = 309 / 21.86 = 14.14 \text{ m/s}$$

$$V_{u1} \text{ at middle} = 309 / 32.79 = 9.42 \text{ m/s}$$

In all cases  $u > V_u \therefore$  Shape of triangle is as given

$$\tan \beta_1 = \frac{V_f}{u - V_u}$$

$$\text{At tip } \tan (180 - \beta_1) = \frac{9.09}{43.72 - 7.07} \therefore \beta_1 = (180 - 13.92)^\circ = 166.08^\circ$$

$$\text{At 3.75 m Dia, } \tan (180 - \beta_1) = \frac{9.09}{32.79 - 9.42} \therefore \beta = (180 - 21.25) = 158.75^\circ$$

$$\text{At hub } \tan (180 - \beta_1) = \frac{9.09}{21.86 - 14.14} \quad \therefore \beta_1 = (180 - 49.66) = 130.34^\circ$$

The trend is that (as measured with  $u$  direction)  $\beta_1$  decreases with radius.

Outlet triangles are similar.

$$\text{At tip: } \tan (180 - \beta_2) = 9.09 / 43.72 \quad \therefore \beta_2 = (180 - 11.75)^\circ$$

$$\text{At 3.75 m Dia: } \tan (180 - \beta_2) = 9.09 / 32.79 \quad \therefore \beta_2 = (180 - 15.5)^\circ$$

$$\text{At hub: } \tan (180 - \beta_2) = 9.09 / 21.86 \quad \therefore \beta_2 = (180 - 22.6)^\circ$$

The trend may be noted.

At the tip

$$\text{Speed ratio} = \frac{u}{\sqrt{2gH}} = \frac{43.72}{\sqrt{2 \times 9.81 \times 35}} = 1.67$$

$$\text{Flow ratio} = \frac{9.09}{\sqrt{2 \times 9.81 \times 35}} = 0.35$$

$$\text{Specific speed} = \frac{167 \sqrt{40 \times 10^6}}{60 \times 35^{1.25}} = 206.8$$

**Problem 14.29** A Kaplan turbine delivers 30 MW and runs at 175 rpm. Overall efficiency is 85% and hydraulic efficiency is 91%. The tip diameter 5 m and the hub diameter is 2 m. Determine the head and the blade angles at the mid radius. The flow rate is  $140 \text{ m}^3/\text{s}$ .

$\rho Q g H \eta_o =$  power delivered

$$\therefore H = 30 \times 10^6 / 1000 \times 9.81 \times 140 \times 0.85 = 25.7 \text{ m}$$

**Power developed** = Power available from fluid  $\times \eta_H$

$$\text{At midradius} = \frac{30}{0.85} \times 10^6 \times 0.93 = 32.82 \text{ kW}$$

$$u = \pi \times \frac{D \times N}{60} = \frac{\pi \times 3.5 \times 175}{60} = 32.07 \text{ m/s}$$

$$\dot{m} u_1 V_{u1} = 32.82 \times 10^6 = 140 \times 10^3 \times 32.07 \times V_{u1}$$

$$\therefore V_{u1} = 7.14 \text{ m/s}$$

(note  $u_1 V_1 =$  constant at all radii)

$$V_f = 4 \times 140 / \pi (5^2 - 2^2) = 8.5 \text{ m/s}$$

$$V_u < u,$$

$\therefore$  The velocity diagram is as given

$$\tan (180 - \beta_1) = \frac{V_f}{u - V_u} = \frac{8.5}{32.07 - 7.14}$$

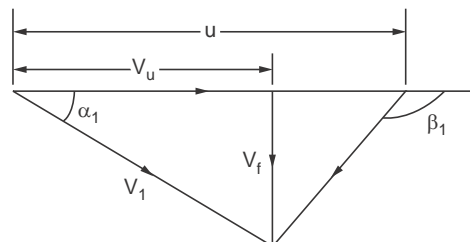

Figure P. 14.29

$$\therefore \quad 180 - \beta = 18.82^\circ,$$

**18.82° with - ve u direction and 161.18° with + ve u direction**

Outlet triangle is right angled as  $V_{u2} = 0$ ,

$$\tan (180 - \beta_2) = \frac{8.5}{32.07}, \quad \beta_2 = 14.8^\circ$$

**with -ve u direction 165.2° with + ve u direction**

$$\tan \alpha_1 = \frac{8.5}{7.14} \quad \therefore \quad \alpha_1 = 50^\circ$$

**Problem 14.30.** A Kaplan turbine works under a head of 26.5 m, the flow rate of water being 170 m<sup>3</sup>/s. The overall efficiency is 90%. Determine the power and specific speed. The turbine speed is 150 rpm.

$$\begin{aligned} \text{Power developed} &= 0.9 \times 170 \times 10^3 \times 9.81 \times 26.5 \text{ W} \\ &= 39.77 \times 10^6 \text{ W or } 39.77 \text{ MW} \end{aligned}$$

**Dimensionless specific speed**

$$= \frac{N\sqrt{P}}{\rho^{1/2} (gH)^{5/4}} = \frac{150}{60} \cdot \frac{\sqrt{39.77 \times 10^6}}{1000^{1/2} \times 9.81^{1.25} \times 26.5^{1.25}} = 0.4776 \text{ rad}$$

**Diamensional specific speed**

$$= \frac{150}{60} \cdot \frac{\sqrt{39.77 \times 10^6}}{26.5^{1.25}} = 262.22.$$

**Problem 14.31.** At a location it is proposed to install a Kaplan turbine with an estimated power of 30 MW at an overall efficiency of 0.89. The head available is 42 m. **Determine the speed it hub tip ratio is 0.5 and the flow ratio and speed ratio are 0.5 and 1.8.**

$$\begin{aligned} \text{The flow rate} &= Q = \frac{\text{Power}}{\eta_o \rho g H} = \frac{30 \times 10^6}{0.89 \times 1000 \times 9.81 \times 42} = 81.81 \text{ m}^3/\text{s} \end{aligned}$$

$$\text{Flow ratio} = V_f \sqrt{2gh} = 0.5.$$

$$\therefore \quad V_f = 0.5 \sqrt{2 \times 9.81 \times 42} = 14.35 \text{ m/s.}$$

$$Q = \frac{\pi}{4} (D^2 - d^2) V_f$$

$$\therefore \quad 81.81 = \frac{\pi}{4} D^2 (1 - 0.5^2) 14.35$$

$$\text{Solving} \quad D = 3.11 \text{ m}$$

$$u = 1.8 \sqrt{2 \times 9.81 \times 42} = 51.67 \text{ m/s}$$

$$u = \frac{\pi D N}{60}, N = \frac{u \times 60}{\pi D} = \frac{51.67 \times 60}{\pi \times 3.11} = 317.3 \text{ rpm}$$

This may not suit 50 cycle operation. The nearest synchronous speed is 333.3 with a 9 pair of poles.

**Problem 14.32.** A Kaplan turbine delivers 10 MW under a head of 25 m. The hub and tip diameters are 1.2 m and 3 m. Hydraulic and overall efficiencies are 0.90 and 0.85. If both velocity triangles are right angled triangles, **determine the speed, guide blade outlet angle and blade outlet angle.**

The inlet velocity diagram is shown in the figure.

Flow rate is calculated from power, head and overall efficiency

$$Q = \frac{10 \times 10^6}{10^3 \times 25 \times 9.81 \times 0.85} = 47.97 \text{ m}^3/\text{s}$$

$$V_f = \frac{47.97 \times 4}{\pi (3^2 - 1.2^2)} = 8.08 \text{ m/s}$$

Power developed

$$u V_{u1} \dot{m} = 10 \times 10^6 / 0.90$$

$$\dot{m} = 47.97 \times 10^3 \text{ kg/s and } u = V_{u1}$$

$$\therefore 47.97 \times 10^3 \times u_1^2 = \frac{10 \times 10^6}{0.9}$$

Solving  $u_1 = 15.22 \text{ m/s}$

$$\therefore \tan \alpha_1 = V_{f1} / u_1 = \frac{8.08}{15.22}$$

$$\therefore \alpha_1 = 28^\circ$$

At the outlet  $u_2 = u_1, V_{f2} = V_{f1}$

$$\therefore \tan \beta = \frac{8.08}{15.22}$$

$$\therefore \beta = 28^\circ$$

$$\frac{\pi D N}{60} = 15.22$$

$$\therefore N = \frac{15.22 \times 60}{\pi \times 3} = 96.9 \text{ rpm}$$

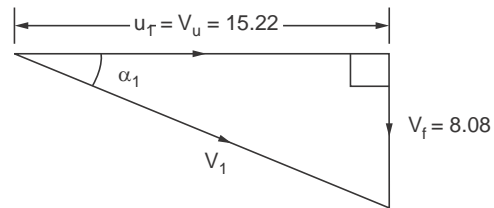

Figure P. 14.32

**Problem 14.33.** In a low head hydro plant, the total head is 7 m. A draft tube is used to recover a part of the kinetic head. If the velocity at the turbine outlet or the draft tube inlet is 7 m/s and that at the outlet is 5 m/s, 7 m/s, 5 m/s, determine the hydraulic efficiency if the draft tube efficiency is 100% and if the draft tube efficiency to recover kinetic energy is 80%. What will be the efficiency if all the exit velocity from the turbine is lost. Assume that there are no other losses.

Total head = 7 m

$$\text{Kinetic head at draft tube inlet} = \frac{7^2}{2 \times 9.81} = 2.5 \text{ m}$$

$$\text{Kinetic head at the draft tube outlet} = \frac{5^2}{2 \times 9.81} = 1.27 \text{ m}$$

When 100% of kinetic head is recovered, head recovered  
 $= 2.5 - 1.27 = 1.23 \text{ m}$

**Case 1:** The maximum gain : 1.23 m

$$\therefore \text{loss} = 2.5 - 1.23 = 1.27$$

$$\therefore \eta_H = (7 - 1.27) / 7 = \mathbf{0.8186} = \mathbf{81.86\%}$$

**Case 2:** If 80% is recovered : gain = 0.8 (2.5 - 1.27) = 0.984 m

$$\text{Head lost} = (2.5 - 0.984) = 1.516$$

$$\therefore \eta_H = (7 - 1.516) / 7 = 0.7834 \text{ or } \mathbf{78.34\%}$$

**Case 3:** If no recovery is achieved

$$\eta_H = (7 - 2.5) / 7 = 0.6429 \text{ or } \mathbf{64.29\%}$$

**Problem 14.34.** In a draft tube arrangement for a propeller turbine the flow rate is  $150 \text{ m}^3/\text{s}$ . Inlet area of the draft tube is  $15 \text{ m}^2$  while the outside area is  $22.5 \text{ m}^2$ . The turbine runner outlet or the draft tube inlet is  $0.5 \text{ m}$  below the tailrace level. If the kinetic head recovered by the draft tube is 80% determine the pressure head at turbine outlet.

Considering the tailrace level as datum and denoting inlet and outlet by suffix 1 and 2.

$$h_1 + \frac{V_1^2}{2g} + Z_1 = h_2 + \frac{V_2^2}{2g} + Z_2 + \text{losses} \quad (\text{A})$$

$$V_1 = 150 / 15 = \mathbf{10 \text{ m/s}}, V_2 = 150 / 22.5 = \mathbf{6.67 \text{ m/s}}$$

$$Z_1 = -\mathbf{0.5 \text{ m}}, Z_2 = \mathbf{0}. \text{ Also } h_2 = \text{atmospheric } pr = \mathbf{10 \text{ m}} \text{ of water}$$

$$\text{Losses} = \frac{0.2(V_1^2 - V_2^2)}{2g}$$

Rearranging the equation (A) and substituting the values, pressure at turbine exit is

$$h_1 = 10 + 0.5 + \left( \frac{6.67^2 - 10^2}{2 \times 9.81} \right) + 0.2 \left( \frac{10^2 - 6.67^2}{2 \times 9.81} \right)$$

$$= 10 + 0.5 - 2.83 + 0.57 = \mathbf{8.24 \text{ m absolute}} \text{ or } \mathbf{1.76 \text{ m vacuum}}.$$

**Problem 14.35.** The inlet of a draft tube of a reaction turbine is  $2.5 \text{ m}$  above the tail race level. The outlet area is 3 times the inlet area. Velocity at inlet is  $8 \text{ m/s}$ . Kinetic head recovery is 80%. Considering atmospheric head as  $10 \text{ m}$  water column, determine the pressure at the draft tube inlet.

Considering tail race level as datum and denoting inlet and outlet by suffixes 1 and 2

$$h_1 + \frac{V_1^2}{2g} + Z_1 = h_2 + \frac{V_2^2}{2g} + Z_2 + \text{Losses} \quad (\text{A})$$

$$V_1 = 8 \text{ m/s}, V_2 = 8 \times \frac{1}{3} = 2.67 \text{ m/s}$$

$$Z_1 = 2.5 \text{ m}, Z_2 = 0, h_2 = 10 \text{ m}$$

$$\text{Losses} = 0.2 \left( \frac{V_1^2 - V_2^2}{2g} \right)$$

Substituting the values,

$$\begin{aligned} h_1 &= 10 - 2.5 + \left( \frac{2.67^2 - 8^2}{2 \times 9.81} \right) + 0.2 \left( \frac{8^2 - 2.67^2}{2 \times 9.81} \right) \\ &= \mathbf{5.18 \text{ m absolute or } 4.82 \text{ m vacuum}} \end{aligned}$$

Head lost by friction and outlet velocity are

$$h_2 = 0.2 \left( \frac{8^2 - 2.67^2}{2 \times 9.81} \right) + \frac{2.67^2}{2 \times 9.81} = 0.58 + 0.36 = \mathbf{0.94 \text{ m.}}$$

## REVIEW QUESTIONS

1. Explain how hydraulic turbines are classified.
2. What are the types of turbines suitable under the following conditions : (a) high head and low discharge (b) medium head and medium discharge and (c) low head and large discharge.
3. What is the advantage gained by diverting the water jet on both sides by the splitter in the buckets of Pelton wheel.
4. List the range of dimensional and non dimensional specific speeds for the various types of hydraulic turbines.
5. For a given power and speed which factor controls the value of specific speed.
6. What are the main advantages of model testing ?
7. Explain why model testing becomes almost mandatory in the case of hydraulic turbines.
8. List the conditions to be satisfied by a model so that it can be considered similar to the prototype.
9. List the dimensionless coefficients used in model testing of hydraulic turbines.
10. Explain how unit quantities are useful in predicting the performance of a given machine under various input output conditions.
11. Explain why a notch is made in lips of Pelton turbine buckets.
12. Explain why penstock pipes are of larger diameter compared to the jet diameters.
13. What is the advantage and limitations in doubling the diameter of a penstock pipe.
14. What is the function of the casing in the pelton turbines ?



3. Dimensionless specific speed for kaplan turbine is about  
 (a) 0.9 (b) 9 (c) 90 (d) 900.
4. Dimensional specific speed for hydraulic turbines is  
 (a)  $\frac{P \sqrt{N}}{H^{3/4}}$  (b)  $\frac{N \sqrt{P}}{H^{1.25}}$  (c)  $\frac{N \sqrt{H}}{P^{3/4}}$  (d)  $\frac{P \sqrt{H}}{N^{3/4}}$ .
5. Overall efficiency of Hydraulic turbines is (the suffixes have the usual meaning)  
 (a)  $\eta_v / \eta_m \cdot \eta_H$  (b)  $\eta_H / \eta_u \cdot \eta_v$  (c)  $\eta_m \eta_H \eta_v$  (d)  $\eta_H \cdot \eta_v / \eta_m$ .
6. A low specific speed Francis turbine is  
 (a) Axial flow turbine (b) tangential flow turbine  
 (c) Mixed flow turbine (d) radial flow turbine.
7. A high specific speed Francis turbine is  
 (a) Radial flow turbine (b) Tangential flow turbine  
 (c) Mixed flow turbine (d) Axial flow turbine.
8. Example of a pure reaction turbine is  
 (a) Francis turbine (b) Propeller turbine  
 (c) Kaplan turbine (d) Lawn sprinkler.
9. Pelton turbine is a  
 (a) Reaction turbine (b) Impulse turbine  
 (c) Radial flow turbine (d) Axial flow turbine.
10. Flow ratio is  
 (a) Flow velocity / blade velocity (b) Flow velocity / Relative velocity  
 (c) Flow velocity /  $\sqrt{2gH}$  (d) Flow velocity /whirl velocity.

### Answers

- (1) a (2) a (3) a (4) b (5) c (6) d (7) c (8) d (9) b (10) c.

### EXERCISE PROBLEMS

- E 14.1.** At a location the power potential was estimated as 4 MW. The head available was 35 m. The speed chosen is 300 rpm. Determine the dimensional and non dimensional specific speeds. If the speed ratio is 0.8 and the flow ratio is 0.35 **determine the diameter of the runner.**
- E 14.2.** The head available at a location is 1000 m. The unit chosen is to run at 300 rpm. The power potential is 120 MW. **Estimate how many units will be required** if these are of single jet type with dimensionless specific speed of 0.021.
- E 14.3.** A model of scale 1/4 is to be designed. The prototype is to develop 8 MW and run at 600 rpm. The head available is 40 m. If the dynamometer facility is limited to 25 kW, **determine the head required and the speed of the model. If the overall efficiency is 85% in both cases, determine the flow rates.**
- E 14.4.** Water is brought by four penstocks of 0.9 m diameter over a distance of 1.6 km to the turbine. At the nozzle inlet the head available is 500 m. The diameter of the four nozzles is 0.2 m each,  $C_v = 0.98$ ,  $f = 0.032$ .  
**Determine the power available in each jet and the head lost by friction. (14.96 MW, 66.8 m).**



- E 14.5.** A Pelton turbine delivers 14.25 MW when running at 600 rpm under a head of 900 m. Assuming an overall efficiency of 89.2%. **Determine the jet diameter and the wheel diameter.** Assume  $C_v = 0.98$  and speed ratio as 0.46. **(134 mm, 1910 mm).**
- E 14.6.** Pelton turbine deliver 15 MW under a head of 1000 m when running at 300 rpm. The blade speed ratio is 0.48 and  $C_v = 0.98$ . The jet is turned through  $165^\circ$  by the bucket. The relative velocity is reduced by 15% by blade friction. **Determine the hydraulic efficiency. Also calculate the wheel diameter and nozzle diameter.** The mechanical and volumetric efficiencies are 0.96 and 0.98. Also find the number of buckets.
- E 14.7.** A Pelton turbine delivers 13 MW at 430 rpm when the head available was 800 m. The overall efficiency is 85% **Determine the diameter of the wheel and diameter of the nozzle.** Assume  $C_v = 0.98$  and blade speed ratio as 0.46. **(2 m, 0.2 m).**
- E 14.8.** **Determine the number and diameter of jets for** a Pelton turbine producing 20 MW under a head of 450 m running at a speed of 475 rpm. The jet diameter is not to exceed one twelfth of the wheel diameter. Also find the diameter of the wheel and water flow rate. Assume overall efficiency is 86% and  $C_v = 0.97$  and  $\phi = 0.46$ .
- E 14.9.** A Pelton wheel has a bucket speed of 20 m/s and jet speed of 42 m/s. The flow rate is 450 kg/s. The jet is deflected by  $165^\circ$ . The relative velocity is reduced by 12% by friction. **Determine the power generated.** What is the efficiency of the unit ? **(36.5 kW, 93.47%)**
- E 14.10.** At a site the head available is 315 m and the maximum power potential is 35 MW. If the dimensionless specific speed is to be in the range 0.015 to 0.02 determine the number of units required and the power of each unit.  
If the overall efficiency is expected to be 85%, determine the flow rate. If  $C_v = 0.97$  and  $\phi = 0.46$ , **determine the speed if the wheel diameter is 10 times the jet diameter.**
- E 14.11.** A Pelton wheel running at 500 rpm develops 5 MW under a net head of 300 m. Assume  $C_v = 0.97$ , speed ratio = 0.46,  $\eta_o = 80\%$ , jet diameter to wheel diameter is 1:10. **Determine the wheel diameter and the number of jets required.** **(1.3 m, 4)**
- E 14.12.** In an impulse turbine of the Pelton type, the jet is turned by the bucket by  $165^\circ$ . The head available at the nozzle is 750 m and blade speed ratio is 0.46.  $C_v = 0.98$ . Relative velocity is reduced by 12% due to friction. Determine the hydraulic efficiency. If the flow available is  $20 \text{ m}^3/\text{s}$ . What is the power potential. Assuming 5 units of equal power, **determine the jet diameter and wheel diameter** if  $d/D = 12$ .
- E 14.13.** A Francis turbine running at 700 rpm works under a head of 160 m. The water enters the runner at 28 m/s, the outlet angle of the guide blade being  $12^\circ$ . The inner and outer diameter are 1.3 m and 0.8 m. Assuming the discharge to be axial and constant flow velocity **determine the runner blade angles. Also calculate the hydraulic efficiency.**
- E 14.14.** In a Francis turbine the runner diameter ratio is  $ID/OD = 0.5$ . The runner width is 0.1  $OD$ , Flow ratio is 0.18. The power is 300 kW under a head of 65 m when running at 700 rpm.  $\eta_H = 94\%$ ,  $\eta_o = 85\%$ .  
**Determine the diameter and blade angles assuming radial flow at exit**  
**( $OD = 0.52 \text{ m}$ ,  $ID = 0.26 \text{ mm}$ ,  $b = 0.052 \text{ m}$ ,  $\alpha_1 = 11.6^\circ$ ,  $\beta_1 = 27.8^\circ$ ,  $\beta_2 = 34^\circ$ ).**
- E 14.15.** In an inward flow reaction turbine the available head is 60 m. The blade angle at inlet is  $100^\circ$ . The flow ratio is 0.3. Hydraulic efficiency is 87%. If the speed is 475 rpm, **determine the runner diameter.** **(0.09 m)**
- E 14.16.** An inward flow reaction turbine develops 185 kW under a head of 30 m. Guide vane outlet angle is  $20^\circ$ . Vane outlet angle is  $25^\circ$  and outlet is radial. The ratio of inlet to outlet area is 3 : 4. Loss in guide vane is 10% of velocity head at inlet. Loss in the runner is 20% of outlet radial velocity head. **Determine the pressure at inlet of the wheel, flow rate, and area at outlet of the guide vanes.** ( $Q = 0.7256 \text{ m}^3/\text{s}$ ,  $0.1163 \text{ m}^2$ )

- E 14.17.** A Francis turbine works under a head of 95 m, the flow rate being  $6 \text{ m}^3/\text{s}$ . The flow velocity remains constant at 18 m/s. The blade inlet is at  $90^\circ$ . The width of the runner at inlet is 0.16 times the diameter and the inner diameter is 0.6 times the outer diameter. **Determine the runner diameter and hydraulic efficiency.** Assume that blade thickness reduces the flow area by 10%. Also calculate **the guide blade and runner outlet angles.** Assume zero whirl at exit.
- E 14.18.** An inward flow reaction turbine has diameters 45 cm and 30 cm the widths being 5 cm and 7.5 cm. Vanes occupy 8% of flow area. Guide vane angle is  $24^\circ$  and runner blade angles are  $95^\circ$  and  $30^\circ$ . Head available is 52.8 m. Hydraulic efficiency is 88%. Mechanical efficiency is 96%. **Determine the turbine speed for smooth flow.** Also find the **power and angle the absolute velocity at exit makes** with tangential direction. **(900 rpm, 455 Nm/s/kg,  $79.6^\circ$ )**
- E 14.19.** An inward flow reaction turbine works under a head of 25 m. The hydraulic efficiency is 80%. The turbine speed is 300 rpm. The peripheral velocity is 30 m/s. The flow velocity is 4 m/s. **Determine the guide blade outlet angle, the runner inlet angle and the runner diameter.** **( $31.4^\circ$ ,  $170.3^\circ$ , 1.91 m)**
- E 14.20.** In a Francis turbine, the wheel peripheral velocity is 24 m/s. The whirl velocity at inlet is 18 m/s. The flow velocity is 6 m/s. The whirl at exit is zero. Assuming no other losses, **determine the head on the turbine. Also find the vane angle at inlet.** **(45.8 m,  $135^\circ$ ).**
- E 14.21.** A Francis turbine works under a head of 14 m. The guide vane outlet angle is  $20^\circ$  and the blade angle at inlet is  $90^\circ$ . The ratio of diameters is 3 : 2. The flow velocity is constant at 4 m/s. **Determine the peripheral velocity of the runner.** Assume zero whirl at exit. **(11 m/s,  $28.6^\circ$ )**
- E 14.22.** A Francis turbine with  $OD = 1 \text{ m}$  and  $b = 0.135 \text{ m}$  runs at 180 rpm. The flow velocity is 3 m/s. The flow is **radial both at inlet and outlet.** **Determine (i) Work done per kg (ii) Power developed and (iii) Hydraulic efficiency.** **(88.7 Nm/kg/s, 113 kW, 90.7%)**
- E 14.23.** In a Francis turbine the guidevane outlet angle is  $10^\circ$ . The inlet blade angle is  $90^\circ$ . The runner diameters are 1 m and 0.5 m. Whirl at exit is zero. The flow velocity is 3 m/s both at inlet and outlet. **Determine the speed of the wheel and the outlet angle of the runner.** **(324 rpm,  $19.4^\circ$ ).**
- E 14.24.** In a Francis turbine installation the total head at entry to the spiral casing is 120 m. The distance to the tailrace from this level is 3 m. The tangential velocity at entrance is 30 m/s. The flow velocity is constant at 9 m/s. The discharge is without whirl. The estimated hydraulic losses are (i) 4.8 m in the guide vanes. (ii) 8.8 m in the rotor. (iii) 0.79 m in the draft tube (iv) kinetic head at exit is 0.46 m. **Determine the guide vane angle at exit, the runner blade angle at inlet and the pressure heads at the runner entry and exit.** Assume  $\eta_H = 0.9$ . **( $14.3^\circ$ ,  $59.46^\circ$ , 47.4 m, - 5.9 m)**
- E 14.25.** A Francis turbine runs at 268 rpm. The outer diameter is 1.2 m. The blade angle at inlet is  $90^\circ$ . If the flow rate is 1 kg/s, determine the power developed. If the head is 30 m determine the hydraulic efficiency. If the guide blade outlet angle is  $15^\circ$  and if the flow velocity is constant, **determine the runner outlet angle.** Whirl at exit is zero. **(92.7%,  $28.2^\circ$ )**
- E 14.26.** A Kaplan turbine runner hub and tip diameters are 2.5 m and 5 m respectively. When running at 150 rpm under a head of 30 m, it develops 30 MW. The overall efficiency is 85% and hydraulic efficiency is 90%. **Determine the runner blade angles at inlet and outlet both at the tip and the hub.** Assume zero whirl at exit, and the product of whirl and tip speed is constant at all diameters. **( $\alpha_{1t} = 14^\circ$ ,  $\beta_{1h} = 52.9^\circ$ ,  $\alpha_{2t} = 11.7^\circ$ ,  $\beta_{2h} = 22.5^\circ$ )**
- E 14.27.** A Kaplan turbine delivers with an overall efficiency of 90%. 25 MW, the head available being 40 m. The speed ratio and flow ratio are 2 and 0.6 respectively. The hub to tip ratio is 0.4. **Determine the diameter and speed of the turbine.** **(2.5 m, 428.6 rpm)**

- E 14.28.** A Kaplan turbine produces 12 MW under a head of 28 m. The hub and tip diameters of the runner are 1.1 m and 2.9 m respectively. If the overall efficiency is 85% and if the inlet and outlet velocity triangles are right angled, **calculate the speed and guide blade and runner outlet angles. Hydraulic efficiency is 94%.**
- E 14.29.** A Kaplan turbine develops 35000 kW while running at 240 rpm. The dimensional specific speed is 320. **Determine the head available.** If the overall efficiency is 84.5% and the hub tip ratio is 0.3 **determine the speed ratio based on outer diameter.** Assume a flow ratio of 0.35. **(21.27 m, 2.525)**
- E 14.30** An axial flow turbine has a tip diameter of 4.5 m and hub diameter of 2.5 m. The power developed is 21 MW. The running speed is 140 rpm. The net head is 20 m. The hydraulic and overall efficiencies are 94% and 80% respectively. **Calculate the guide vane outlet angle and the blade inlet angle.** **(63.2°, 22.05°)**
- E 14.31.** An axial flow turbine of the Kaplan type develops 20 MW when working under a head of 20 m. The speed ratio is 2. The flow ratio is 0.6. The hub diameter is 35% of the tip diameter. **Calculate the turbine speed and diameter.** **(198 rpm, 3.8 m)**
- E 14.32.** A Kaplan turbine operates under a net head of 20 m and develops 16 MW with a hydraulic efficiency of 90 percent and overall efficiency of 80 percent. The runner outer diameter is 4.2 m. The hub diameter is 2 m. The dimensionless specific speed is 0.8. **Determine the blade inlet and outlet angles at the tip if  $V_{u2} = 0$ .** **(9.2°, 18°)**
- E 14.33.** An axial flow turbine develops 7.5 MW under a head of 5.5 m with an overall efficiency of 85%. The hub diameter is 1/3 of the tip diameter. **Determine the diameter and speed of the runner.** **(5.58 m, 75 rpm)**
- E 14.34.** In a draft tube fixed to a reaction turbine the inlet diameter is 3 m and the outlet area is 20 m<sup>2</sup>. The velocity at inlet is 5 m/s. The turbine exit is 5 m above the tail race level. The loss in the draft tube is 50% of the velocity head at outlet, **Determine the pressure at the top of the draft tube.** Also find the head lost in the draft tube. **(6.03 m vacuum, 0.08 m)**
- E 14.35.** The following data refer to the draft tube of a large Francis turbine. Inlet area 25 m<sup>2</sup>, Area at exit 75 m<sup>2</sup>, velocity at inlet : 12 m/s. The level above tailrace level of turbine outlet = 0.9 m. If the loss in the draft tube due to friction is 20% of the inlet kinetic energy **determine the vacuum at the turbine outlet. Also find the power wasted in the exit kinetic energy.** **(5.95 m, vacuum, 2000 kW)**
- E 14.36.** The inlet diameter of a draft tube is 3 m. The height above tailrace is 2.5 m. The pressure measured at the top was 3.1 m vacuum. The flow rate is 30 m<sup>3</sup>/s. **Determine the efficiency of the draft tube.** **(65.5%)**
- E 14.37.** A Francis turbine for a power plant is to be designed for a power of 30 MW. The head available is 190 m. The speed is to be 180 rpm. A model for the unit is to be designed. The power available in the laboratory is 40 kW. A one sixth scale model is to be adopted. **Determine the speed, head and flow rate** for the model. Assume an overall efficiency of 98%.
- E 14.38.** The speed ratio in a Pelton turbine is 0.46. The head available is 300 m. The flow rate available is 2.5 m<sup>3</sup>/s. The coefficient of velocity is 0.98. The diameter should not exceed 3 m. The jet is deflected by 167°. The blade friction coefficient is 0.1. **Determine the hydraulic efficiency. Also determine the speed and power delivered. Mechanical efficiency is 87%.**
- E 14.39.** A Pelton turbine is to deliver 12 MW. The mechanical and generator efficiencies are 0.85 and 0.95. The head available is 700 m.  $C_v = 0.98$ . Blade speed ratio is 0.46. The jet is deflected by 165°. Blade friction reduces the relative velocity by 12%. **Determine the overall efficiency, flow rate and jet diameter.** If the speed is 180 rpm, **determine the wheel diameter.**