

Chapter 2

Introduction to HVAC Systems

Contents of Chapter 2

Instructions

Objectives of Chapter 2

2.1 Introduction

2.2 Introducing the Psychrometric Chart

2.3 Basic Air-Conditioning System

2.4 Zoned Air-Conditioning Systems

2.5 Choosing an Air-Conditioning System

2.6 System Choice Matrix

The Next Step

Summary

Bibliography

Instructions

Read the material of Chapter 2. Re-read the parts of the chapter that are emphasized in the summary.

Objectives of Chapter 2

Chapter 2 begins with an introduction to a graphical representation of air-conditioning processes called the psychrometric chart. Next, an air-conditioning system is introduced followed by a discussion about how it can be adapted to serve many spaces. The chapter ends with a brief introduction to the idea of using a factor matrix to help choose an air-conditioning system.

Chapter 2 is broad in scope and will also introduce you to the content and value of other, more in depth, ASHRAE Self-Study Courses. After studying Chapter 2, you should be able to:

- Understand and describe the major concepts of the psychrometric chart.
- Define the main issues to be considered when designing a system.
- Name the four major system types and explain their differences.
- Describe the main factors to be considered in a matrix selection process.

2.1 Introduction

In Chapter 1 we introduced the seven main air-conditioning processes and the task of establishing objectives for air-conditioning design. In this chapter we will consider:

- How these processes are described graphically in the psychrometric chart.
- How these processes are combined to form an air-conditioning system.
- The range of heating, ventilating, and air-conditioning systems.
- How system choices are made.

2.2 Introducing the Psychrometric Chart

Many of the air-conditioning processes involve air that is experiencing energy changes. These changes arise from changes in the air's temperature and its moisture content. The relationships between temperature, moisture content, and energy are most easily understood using a visual aid called the "**psychrometric chart.**"

The psychrometric chart is an industry-standard tool that is used to visualize the interrelationships between dry air, moisture, and energy. If you are responsible for the design or maintenance of any aspect of air conditioning in buildings, a clear and comfortable understanding of the chart will make your job easier.

Initially, the chart can be intimidating, but as you work with it, you will discover that the relationships that it illustrates are relatively easy to understand. Once you are comfortable with it, you will discover that it is a tool that can make it easier to troubleshoot air-conditioning problems in buildings. The ASHRAE course, *Fundamentals of Thermodynamics and Psychrometrics*,¹ goes into great detail about the use of the chart. That course also provides calculations and discussion about how the chart can be used as a design and troubleshooting tool.

In this course, however, we will only introduce the psychrometric chart, and provide a very brief overview of its structure.

The Design of the Psychrometric Chart

The psychrometric chart is built upon two simple concepts.

1. Indoor air is a mixture of dry air and water vapor.
2. There is a specific amount of energy in the mixture at a specific temperature and pressure.

Psychrometric Chart Concept 1: Indoor Air is a Mixture of Dry Air and Water Vapor.

The air we live in is a mixture of both **dry air** and **water vapor**. Both are invisible gases. The water vapor in air is also called **moisture** or **humidity**. The quantity of water vapor in air is expressed as "**grams of water vapor per kilogram of air.**" This ratio is called the "humidity ratio," abbreviation W and the units are grams of water/kilogram of dry air, g_w/kg_{da} , often abbreviated to g/kg .

The exact properties of moist air vary with pressure. Because pressure reduces as altitude increases, the properties of moist air change with altitude.

Typically, psychrometric charts are printed based on standard pressure at sea level. For the rest of this course we will consider pressure as constant.

To understand the relationship between water vapor, air, and temperature, we will consider two conditions:

First Condition: The temperature is constant, but the quantity of water vapor is increasing.

If the temperature remains constant, then, as the quantity of water vapor in the air increases, the humidity increases. However, at every temperature point, there is a maximum amount of water vapor that can co-exist with the air. The point at which this maximum is reached is called the **saturation point**. If more water vapor is added after the saturation point is reached, then an equal amount of water vapor condenses, and takes the form of either water droplets or ice crystals.

Outdoors, we see water droplets in the air as fog, clouds, or rain and we see ice crystals in the air as snow or hail. The psychrometric chart only considers the conditions up to the saturation point; therefore, it only considers the effects of water in the vapor phase, and does not deal with water droplets or ice crystals.

Second Condition: The temperature is dropping, but the quantity of water vapor is constant.

If the air is cooled sufficiently, it reaches the **saturation line**. If it is cooled even more, moisture will condense out and dew forms.

For example, if a cold canned drink is taken out of the refrigerator and left for a few minutes, the container gets damp. This is because the moist air is in contact with the chilled container. The container cools the air that it contacts to a temperature that is below saturation, and dew forms. This temperature, at which the air starts to produce condensation, is called the **dew point temperature**.

Relative Humidity

Figure 2-1 is a plot of the maximum quantity of water vapor per pound of air against air temperature. The X-axis is temperature. The Y-axis is the proportion of water vapor to dry air, measured in grams of water vapor per kilogram

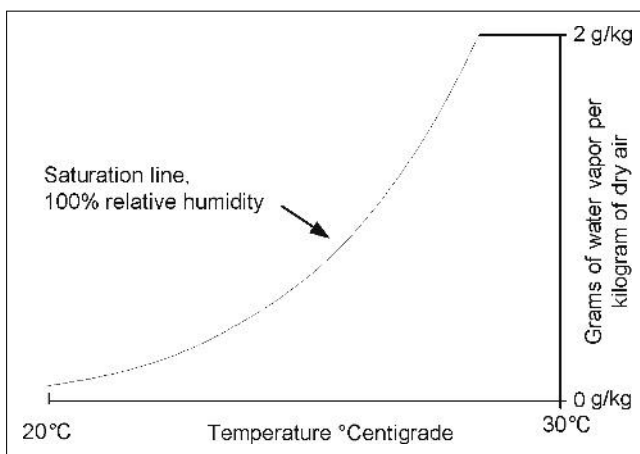

Figure 2-1 Psychrometric Chart—Saturation Line

of dry air. The curved “maximum water vapor line” is called the “saturation line.” It is also known as **100% relative humidity**, abbreviated to **100% rh**. At any point on the saturation line, the air has 100% of the water vapor per pound of air that can coexist with dry air at that temperature.

When the same volume of air contains only half the weight of water vapor that it has the capacity to hold at that temperature, we call it **50% relative humidity** or **50% rh**. This is shown in *Figure 2-2*. Air at any point on the 50% rh line has half the water vapor that the same volume of air could have at that temperature.

As you can see on the chart, the maximum amount of water vapor that moist air can contain increases rapidly with increasing temperature. For example, moist air at the freezing point, 0°C , can contain only 0.4% of its weight as water vapor. However, indoors, at a temperature of 22°C the moist air can contain nearly 1.7% of its weight as water vapor—over four times as much.

Consider *Figure 2-3*, and this example:

On a miserable wet day it might be 5°C outside, with the air rather humid, at 80% relative humidity. Bring that air into your building. Heat it to 22°C . This brings the relative humidity down to about 25%. This change in relative humidity is shown in *Figure 2-3*, from **Point 1** \rightarrow **2**. A cool damp day outside provides air for a dry day indoors! Note that the absolute amount of water vapor in the air has remained the same, at 4 grams of water vapor per kilogram of dry air; but as the temperature rises, the relative humidity falls.

Here is an example for you to try, using *Figure 2-3*.

Suppose it is a warm day with an outside temperature of 30°C and relative humidity at 50%. We have an air-conditioned space that is at 22°C . Some of the outside air leaks into our air-conditioned space. This leakage is called **infiltration**.

Plot the process on *Figure 2-3*.

Find the start condition, 30°C and 50% rh, moisture content 12 g/kg.

Then cool this air: move left, at constant moisture content to 23°C .

Notice that the cooled air now has a relative humidity of about 75%.

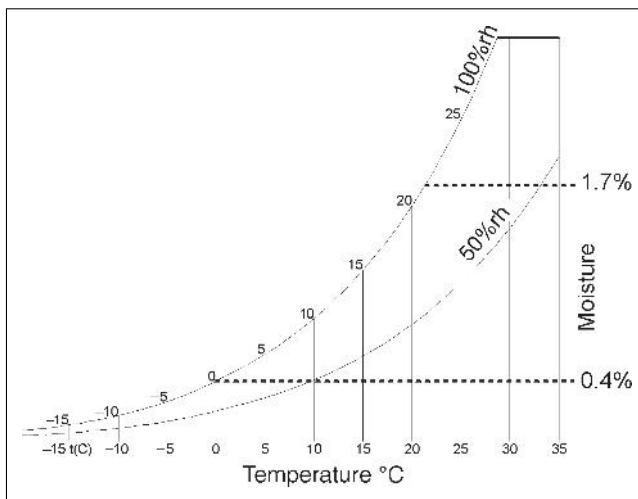

Figure 2-2 Psychrometric Chart—50% Relative Humidity Line

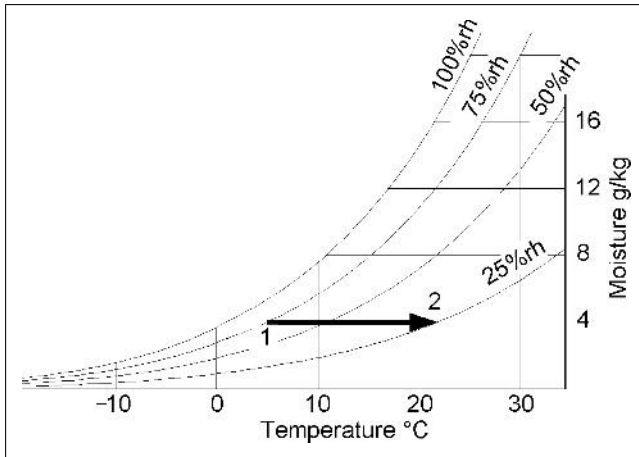

Figure 2-3 Psychrometric Chart—Change in Relative Humidity with Change in Temperature

Relative humidity of 75% is high enough to cause mold problems in buildings. Therefore in hot moist climates, to prevent infiltration and mold generation, it is valuable to maintain a small positive pressure in buildings.

Psychrometric Chart Concept 2: There is a specific amount of energy in the air mixture at a specific temperature and pressure.

This brings us to the second concept that the psychrometric chart illustrates. There is a specific amount of energy in the air water-vapor mixture at a specific temperature. The energy of this mixture is dependent on two measures:

1. The temperature of the air.
2. The proportion of water vapor in the air.

There is more energy in air at higher temperatures. The addition of heat to raise the temperature is called adding “**sensible heat**.” There is also more energy when there is more water vapor in the air. The energy that the water vapor contains is referred to as its “**latent heat**.”

The measure of the total energy of both the sensible heat in the air and the latent heat in the water vapor is commonly called “**enthalpy**.” Enthalpy can be raised by adding energy to the mixture of dry air and water vapor. This can be accomplished by adding either or both

- Sensible heat to the air
- More water vapor, which increases the latent heat of the mixture.

On the psychrometric chart, lines of constant enthalpy slope down from left to right as shown in *Figure 2-4* and are labeled “**Enthalpy**.”

The zero is arbitrarily chosen as zero at 0°C and zero moisture content. The unit measure for enthalpy is **kilojoules per kilogram of dry air**, abbreviated as **kJ/kg**.

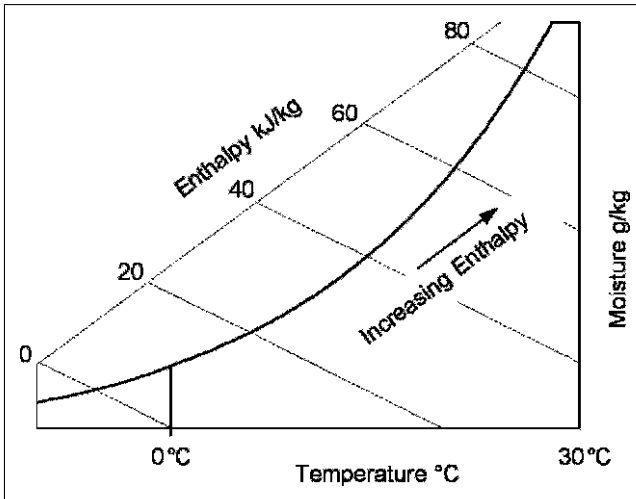

Figure 2-4 Psychrometric Chart—Enthalpy

Heating

The process of heating involves the addition of sensible heat energy. *Figure 2-5* illustrates outside air at 5°C and almost 80% relative humidity that has been heated to 22°C. This process increases the enthalpy in the air from approximately 16 kJ/kg to 33 kJ/kg. Note that the process line is **horizontal** because no water vapor is being added to or removed from the air—we are just heating the mixture. In the process, the relative humidity drops from almost 80% rh down to about 25% rh.

Here is an example for you to try.

Plot this process on *Figure 2-6*.

Suppose it is a cool day with an outside temperature of 6°C and 50% rh. We have an air-conditioned space and the air is heated to 20°C. There is no

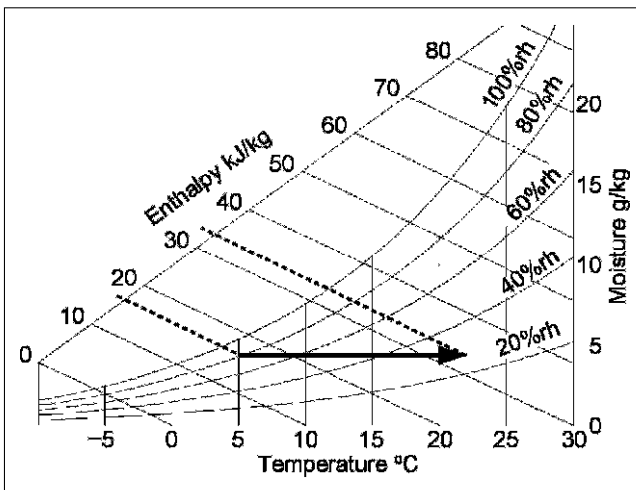

Figure 2-5 Psychrometric Chart—Heating Air from 5°C to 22°C

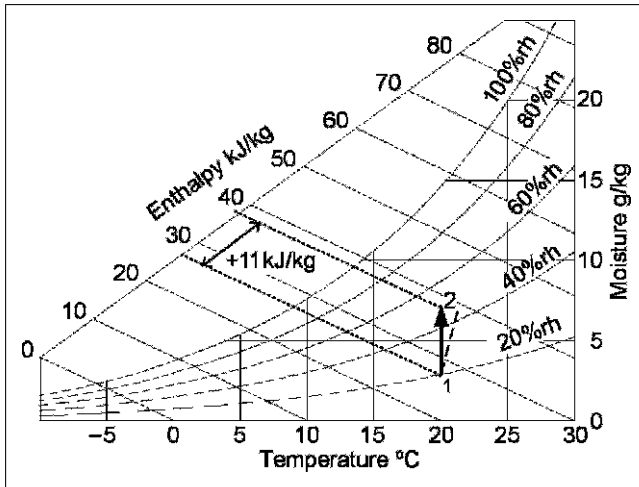

Figure 2-6 Psychrometric Chart—Adding Moisture with Steam

change in the amount of water vapor in the air. The enthalpy rises from about 16 kJ/kg to 33 kJ/kg, an increase of 17 kJ/kg.

As you can see, the humidity would have dropped to 20% rh. This is quite dry so let us assume that we are to raise the humidity to a more comfortable 50%. As you can see on the chart, this raises the enthalpy by an additional 11 kJ/kg.

Humidification

The addition of water vapor to air is a process called “**humidification.**” Humidification occurs when water absorbs energy, evaporates into water vapor, and mixes with air. The energy that the water absorbs is called “**latent heat.**”

There are two ways for humidification to occur. In both methods, energy is added to the water to create water vapor.

1. **Water can be heated.** When heat energy is added to the water, the water is transformed to its gaseous state, steam that mixes into the air. In *Figure 2-6*, the vertical line, from Point 1 to Point 2, shows this process. The heat energy, 11 kJ/kg, is put into the water to generate steam (vaporize it), which is then mixed with the air.

In practical steam humidifiers, the added steam is hotter than the air and the piping loses some heat into the air. Therefore, the air is both humidified and heated due to the addition of the water vapor. This combined humidification and heating is shown by the dotted line which slopes a little to the right in *Figure 2-6*.

2. **Water can evaporate** by spraying a fine mist of water droplets into the air. The fine water droplets absorb heat from the air as they evaporate. Alternatively, but using the same evaporation process, air can be passed over a wet fabric, or wet surface, enabling the water to evaporate into the air.

In an evaporative humidifier, the evaporating water absorbs heat from the air to provide its latent heat for evaporation. As a result, the air temperature drops as it is humidified. The process occurs with no external addition or

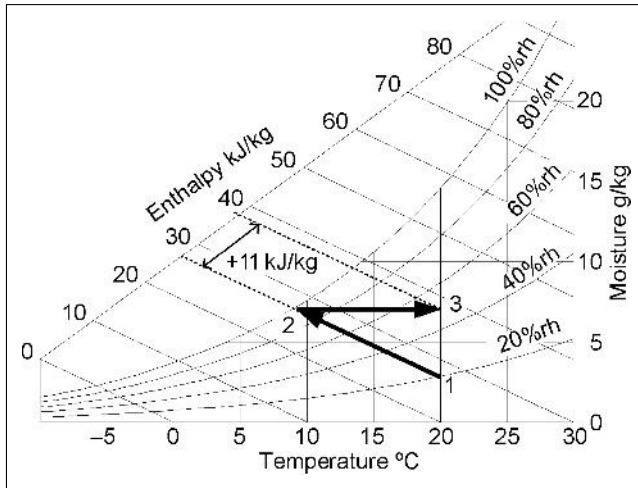

Figure 2-7 Psychrometric Chart—Adding Moisture, Evaporative Humidifier

removal of heat. It is called an **adiabatic process**. Since there is no change in the heat energy (enthalpy) in the air stream, the addition of moisture, by evaporation, occurs along a line of constant enthalpy.

Figure 2-7 shows the process. From Point 1, the moisture evaporates into the air and the temperature falls to 9°C, Point 2. During this evaporation, the relative humidity rises to about 95%. To reach our target of 20°C and 50% rh we must now heat the moistened air at Point 2 from 9°C to 20°C, Point 3, requiring 11 kJ/kg of dry air.

To summarize, we can humidify by adding heat to water to produce steam and mixing the steam with the air, or we can evaporate the moisture and heat the moistened air. We achieve the same result with the same input of heat by two different methods.

The process of evaporative cooling can be used very effectively in a hot, dry desert climate to pre-cool the incoming ventilation air. For example, outside air at 35°C and 15% relative humidity could be cooled to 26°C by passing it through an evaporative cooler. The relative humidity will rise, but only to about 40%. Even with no mechanical refrigeration, this results in a pleasant reduction in air temperature without raising the relative humidity excessively.

Cooling and dehumidification

Cooling is most often achieved in an air-conditioning system by passing the moist air over a cooling coil. As illustrated in *Figure 2-8*, a coil is constructed of a long serpentine pipe through which a cold liquid or gas flows. This cold fluid is either chilled water, typically between 4.5°C and 7.5°C, or a refrigerant. The pipe is lined with fins to increase the heat transfer from the air to the cold fluid in the pipe. *Figure 2-8* shows the face of the coil, in the direction of airflow. Depending on the coil design, required temperature drop, and moisture removal performance, the coil may have 2 to 8 rows of piping. Generally the more rows, the higher the moisture removal ability of the coil.

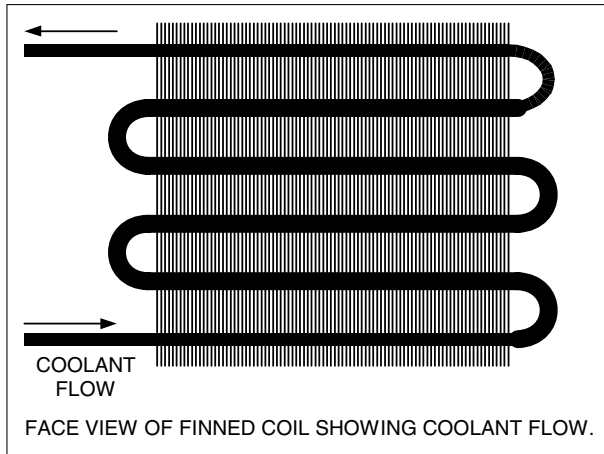

Figure 2-8 Cooling Coil

There are two results. First, the cooling coil cools the air as the air passes over the coils. Second, because the cooling fluid in the coil is usually well below the saturation temperature of the air, moisture condenses on the coil, and drips off, to drain away. This process reduces the enthalpy, or heat, of the air mixture and increases the enthalpy of the chilled water or refrigerant. In another part of the system, this added heat must be removed from the chilled water or refrigerant to recool it for reuse in the cooling coil.

The amount of moisture that is removed depends on several factors including:

- The temperature of the cooling fluid
- The depth of the coil
- Whether the fins are flat or embossed
- The air velocity across the coil.

An example of the typical process is shown in *Figure 2-9*.

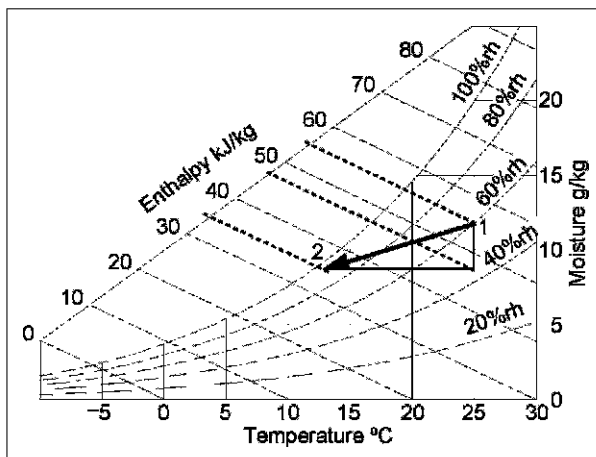

Figure 2-9 Psychrometric Chart—Cooling Across a Wet Cooling Coil

The warm moist air comes into the building at 25°C and 60% rh, and passes through a cooling coil. In this process, the air is being cooled to 13°C. As the moisture condenses on the coil, it releases its latent heat and this heat has to be removed by the cooling fluid. In *Figure 2-9* the moisture removal enthalpy, $A \rightarrow B$, is about a third of the enthalpy required to cool the air, $B \rightarrow C$.

This has been a very brief introduction to the concepts of the psychrometric chart. A typical chart is shown in *Figure 2-10*. It looks complicated, but you know the simple underlying ideas:

Indoor air is a mixture of dry air and water vapor.

There is a specific amount of total energy, called enthalpy, in the mixture at a specific temperature, moisture content, and pressure.

There is a maximum limit to the amount of water vapor in the mixture at any particular temperature.

The actual use of the chart for design, including the calculations, is detailed in the ASHRAE course *Fundamentals of Thermodynamics and Psychrometrics*.¹

Now that we have an understanding of the relationships of dry air, moisture, and energy at a particular pressure we will consider an air-conditioning plant that will provide all seven basic functions of an air-conditioning system to a single space. Remember, the processes required are: heating, cooling, dehumidifying, humidifying, ventilating, cleaning, and air movement.

2.3 Basic Air-Conditioning System

Figure 2-11 shows the schematic diagram of an air-conditioning plant. The majority of the air is drawn from the space, mixed with outside ventilation air and then conditioned before being blown back into the space.

As you discovered in Chapter 1, air-conditioning systems are designed to meet a variety of objectives. In many commercial and institutional systems, the ratio of outside ventilation air to return air typically varies from 15% to 25% of outside air. There are, however, systems which provide 100% outside air with zero recirculation.

The components, from left to right, are:

Outside Air Damper, which closes off the outside air intake when the system is switched off. The damper can be on a spring return with a motor to drive it open; then it will automatically close on power failure. On many systems there will be a metal mesh screen located upstream of the filter, to prevent birds and small animals from entering, and to catch larger items such as leaves and pieces of paper.

Mixing chamber, where return air from the space is mixed with the outside ventilation air.

Filter, which cleans the air by removing solid airborne contaminants (dirt). The filter is positioned so that it cleans the return air and the ventilation air. The filter is also positioned upstream of any heating or cooling coils, to keep the coils clean. This is particularly important for the cooling coil, because the coil is wet with condensation when it is cooling.

Heating coil, which raises the air temperature to the required supply temperature.



ASHRAE PSYCHROMETRIC CHART NO. 1

NORMAL TEMPERATURE

BAROMETRIC PRESSURE: 29.921 INCHES OF MERCURY

COPYRIGHT 1992

AMERICAN SOCIETY OF HEATING, REFRIGERATING AND AIR-CONDITIONING ENGINEERS, INC.

SEA LEVEL

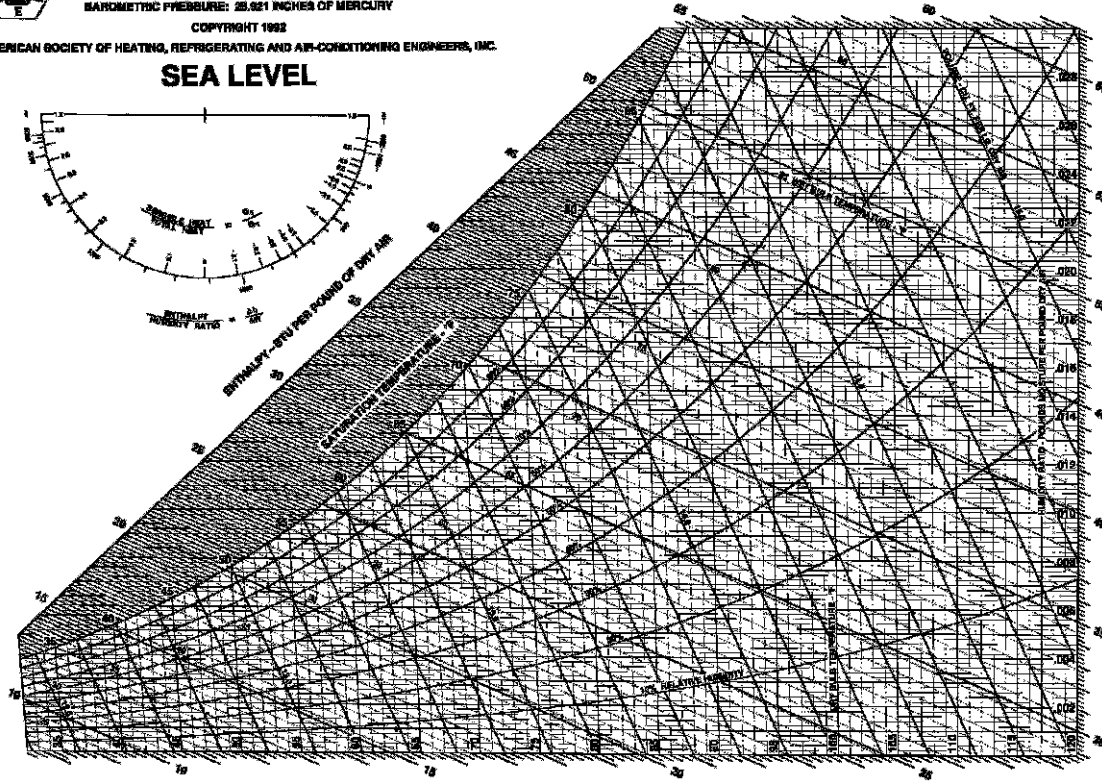

Figure 2-10 ASHRAE Psychrometric Chart

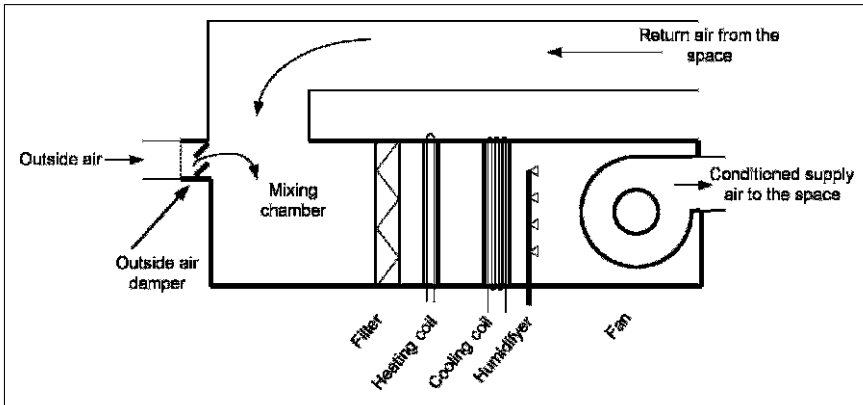

Figure 2-11 Air-Conditioning Plant

Cooling coil, which provides cooling and dehumidification. A thermostat mounted in the space will normally control this coil. A single thermostat and controller are often used to control both the heating and the cooling coil. This method reduces energy waste, because it ensures the two coils cannot both be “on” at the same time.

Humidifier, which adds moisture, and which is usually controlled by a **humidistat** in the space. In addition, a high humidity override humidistat will often be mounted just downstream of the fan, to switch the humidification “off” if it is too humid in the duct. This minimizes the possibility of condensation forming in the duct.

Fan, to draw the air through the resistance of the system and blow it into the space.

These components are controlled to achieve six of the seven air-conditioning processes.

Heating: directly by the space thermostat controlling the amount of heat supplied by the heating coil.

Cooling: directly by the space thermostat controlling the amount of cooling supplied to the cooling coil.

Dehumidifying: by default when cooling is required, since, as the cooling coil cools the air, some moisture condenses out.

Humidifying: directly, by releasing steam into the air, or by a very fine water spray into the air causing both humidification and cooling.

Ventilating: provided by the outside air brought in to the system.

Cleaning: provided by the supply of filtered air.

Air movement within the space is not addressed by the air-conditioning plant, but rather by the way the air is delivered into the space.

Economizer Cycle

In many climates there are substantial periods of time when cooling is required and the return air from the space is warmer and moister than the outside air. During these periods, you can reduce the cooling load on the cooling coil by bringing in more outside air than that required for ventilation. This can be

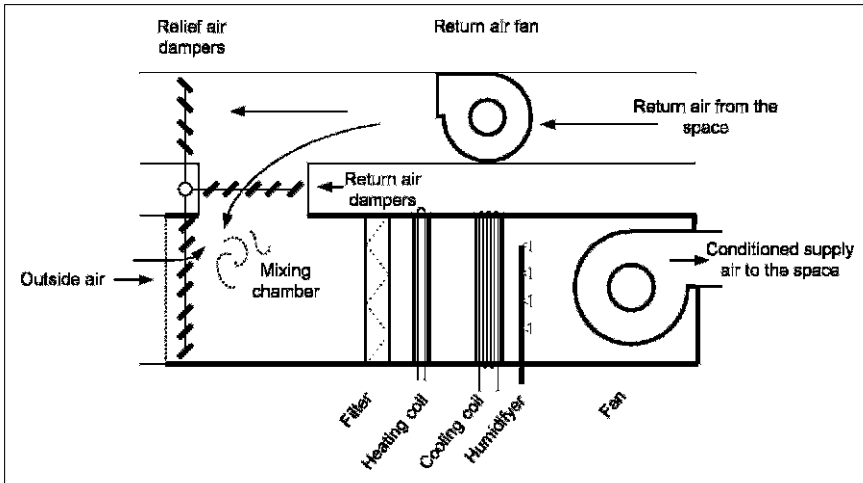

Figure 2-12 Air-Conditioning Plant with Economizer Cycle

accomplished by expanding the design of the basic air-conditioning system to include an **economizer**.

The economizer consists of three (or four) additional components as shown in *Figure 2-12*.

Expanded air intake and damper, sized for 100% system flow.

Relief air outlet with automatic damper, to exhaust excess air to outside.

Return air damper, to adjust the flow of return air into the mixing chamber.

(Optional) Return fan in the return air duct. The return fan is often added on economizer systems, particularly on larger systems. If there is no return fan, the main supply fan must provide enough positive pressure in the space to force the return air out through any ducting and the relief dampers. This can cause unacceptable pressures in the space, making doors slam and difficult to open. When the return air fan is added it will overcome the resistance of the return duct and relief damper, so the space pressure stays near neutral to outside.

Example: Let us consider the operation of the economizer system in *Figure 2-13*. The particular system operating requirements and settings are:

The system is required to provide supply air at 13°C

Return air from the space is at 24°C

Minimum outside air requirement is 20%,

Above 20°C, the system will revert to minimum outside air for ventilation.

In *Figure 2-13*, the outside temperature is shown along the x-axis from -40°C to $+40^{\circ}\text{C}$. We are going to consider the economizer operation from -40°C up to 40°C , working across *Figure 2-13* from left to right.

At -40°C , the minimum 20% outside air for ventilation is mixing with 80% return air at 24°C and will produce a mixed temperature of only 11.2°C . Therefore, in order to achieve the required supply air at 13°C , the heater will have to increase the temperature by 1.8°C .

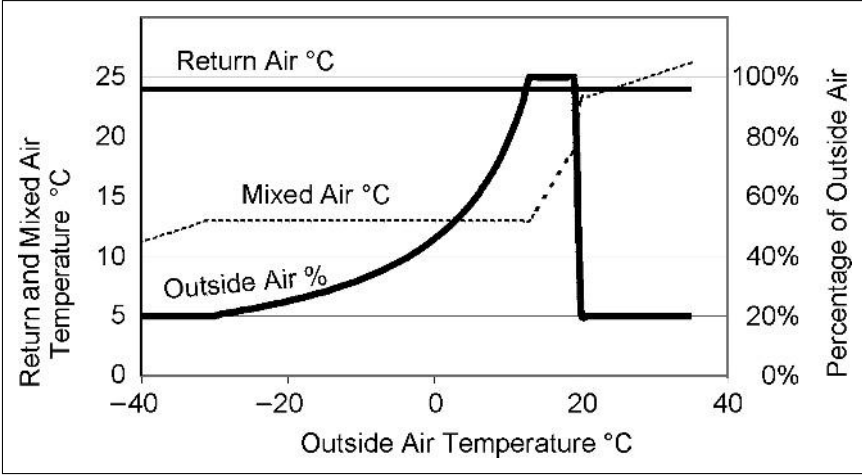

Figure 2-13 Economizer Performance

At -31°C , the minimum outside air for ventilation, 20%, is mixing with 80% return air at 24°C to produce a mixed temperature of 13°C , so the supply air will no longer require any additional heating.

As the temperature rises above -31°C the proportion of outside air will steadily increase to maintain a mixed temperature of 15°C . When the outside air temperature reaches 15°C the mixture will be 100% outside air (and 0% return air). This represents full economizer operation.

Above 15°C the controls will maintain 100% outside air but the temperature will rise as does the outside temperature. The cooling coil will come on to cool the mixed air to the required 15°C .

In this example, at 20°C the controls will close the outside air dampers, and allow only the required 20% ventilation air into the mixing chamber.

From 20°C to 40°C the system will be mixing 20% outside air and 80% return air. This will produce a mixture with temperature rising from 23.2°C to 27.2°C as the outside air temperature rises from 20°C to 40°C .

The useful economizer operation is from -31°C to 20°C . Below -31°C the economizer has no effect, since the system is operating with the minimum 20% outside ventilation air intake. In this example, 20°C was a predetermined changeover point. Above 20°C , the economizer turns off, and the system reverts to the minimum outside air amount, 20%.

The economizer is a very valuable energy saver for climates with long periods of cool weather. For climates with warm moist weather most of the year, the additional cost is not recovered in savings. Also, for spaces where the relative humidity must be maintained above $\sim 45\%$, operation in very cold weather is uneconomic. This is because cold outside air is very dry, and considerable supplementary humidification energy is required to humidify the additional outside air.

2.4 Zoned Air-Conditioning Systems

The air-conditioning system considered so far provides a single source of air with uniform temperature to the entire space, controlled by one space

thermostat and one space humidistat. However, in many buildings there are a variety of spaces with different users and varying thermal loads. These varying loads may be due to different inside uses of the spaces, or due to changes in cooling loads because the sun shines into some spaces and not others. Thus our simple system, which supplies a single source of heating or cooling, must be modified to provide independent, variable cooling or heating to each space.

When a system is designed to provide independent control in different spaces, each space is called a “zone.” A zone may be a separate room. A zone may also be part of a large space. For example, a theatre stage may be a zone, while the audience seating area is a second zone in the same big space. Each has a different requirement for heating and cooling.

This need for zoning leads us to the four broad categories of air-conditioning systems, and consideration of how each can provide zoned cooling and heating. The four systems are

1. All-air systems
2. Air-and-water systems
3. All-water systems
4. Unitary, refrigeration-based systems.

System 1: All-air systems

All-air systems provide air conditioning by using a tempered flow of air to the spaces. These all-air systems need substantial space for ducting the air to each zone.

The cooling or heating capacity, Q , is measured in Joules or Watts and is the product of airflow, measured in cubic meters per second (m^3/s), times the difference in temperature between the supply air to the zone and the return air from the zone.

$$Q = \text{Constant} \cdot \text{mass flow} \cdot \text{temperature difference}$$

$$Q \text{ (Joules)} = \text{Constant for Joules} \cdot \text{m}^3/\text{s} \cdot (\text{C}_{\text{zone}} - \text{C}_{\text{supply air}})$$

$$Q \text{ (Watts)} = \text{Constant for Watts} \cdot \text{m}^3/\text{s} \cdot (\text{C}_{\text{zone}} - \text{C}_{\text{supply air}})$$

To change the heating or cooling capacity of the air supply to one zone, the system must either alter the supply temperature, $^{\circ}\text{C}$, or alter the flow, m^3/s , to that zone.

Reheat system: The simplest, and least energy efficient system, is the constant volume reheat system. Let us assume that the main air system provides air that is cool enough to satisfy all possible cooling loads, and that there is a heater in the duct to each zone.

A zone thermostat can then control the heater to maintain the desired zone setpoint temperature. The system, shown in *Figure 2-14*, is called a **reheat system**, since the cool air is reheated as necessary to maintain zone temperature.

Figure 2-14 illustrates the basic air-conditioning system, plus ducting, to only two of many zones. The air to each zone passes over a reheat coil before entering the zone. A thermostat in the zone controls the reheat coil. If the zone requires full cooling, the thermostat will shut off the reheat coil. Then, as the cooling load drops, the thermostat will turn on the coil to maintain the zone temperature.

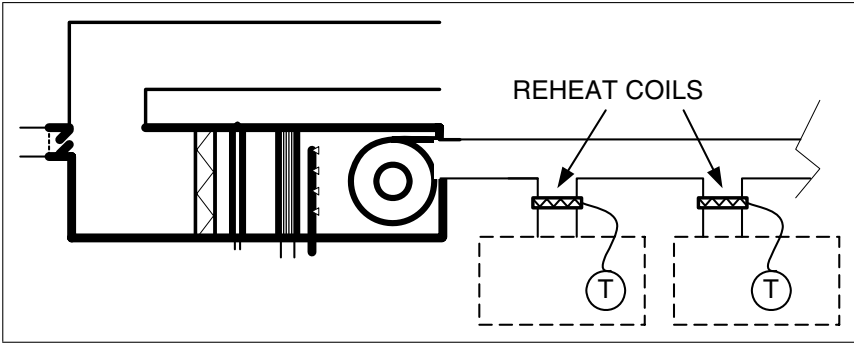

Figure 2-14 Reheat System

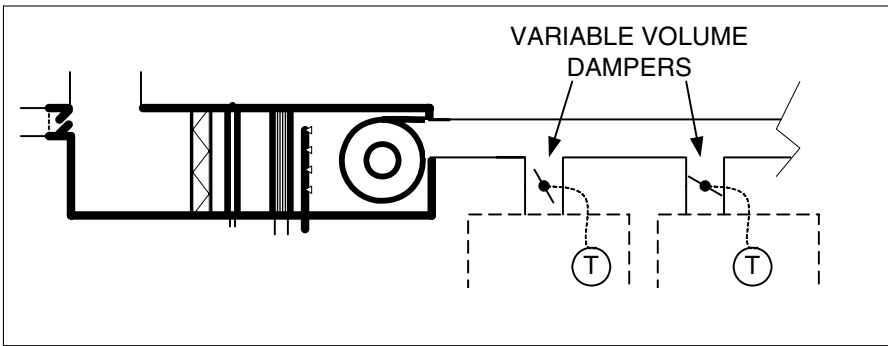

Figure 2-15 Variable Air Volume (VAV) System

Variable Air Volume (VAV) System: *Figure 2-15* illustrates another zoned system, called a Variable Air Volume system (VAV system), because it varies the volume of air supplied to each zone.

Variable Air Volume systems are more energy efficient than the reheat systems. Again, assume that the basic system provides air that is cool enough to satisfy all possible cooling loads. In zones that require only cooling, the duct to each zone can be fitted with a control damper that can be throttled to reduce the airflow to maintain the desired temperature.

In both types of systems, all the air-conditioning processes are achieved through the flow of air from a central unit into each zone. Therefore, they are called “**all-air systems**.” We will discuss these systems in a bit more detail in Chapter 7. However, to design and choose systems, you will need the detailed information found in the ASHRAE course *Fundamentals of Air System Design*.²

System 2: Air-and-water systems

Another group of systems, air-and-water systems, provide all the primary ventilation air from a central system, but local units provide additional conditioning. The primary ventilation system also provides most, or all, of the humidity control by conditioning the ventilation air. The local units are usually supplied with hot or chilled water. These systems are particularly effective in perimeter spaces, where high heating and cooling loads occur. Although they may use electric coils instead of water, they are grouped under the title “**air-and-water systems**.” For example, in cold climates substantial heating is

often required at the perimeter walls. In this situation, a hot-water-heating system can be installed around the perimeter of the building while a central air system provides cooling and ventilation.

System 3: All-water systems

When the ventilation is provided through natural ventilation, by opening windows, or other means, there is no need to duct ventilation air to the zones from a central plant. This allows all processes other than ventilation to be provided by local equipment supplied with hot and chilled water from a central plant. These systems are grouped under the name “**all-water systems.**”

The largest group of all-water systems are heating systems. We will introduce these systems, pumps and piping in Chapters 8 and 9. The detailed design of these heating systems is covered in the ASHRAE course *Fundamentals of Heating Systems*.³

Both the air-and-water and all-water systems rely on a central supply of hot water for heating and chilled water for cooling. The detailed designs and calculations for these systems can be found in the ASHRAE course *Fundamentals of Water System Design*.⁴

System 4: Unitary, refrigerant-based systems

The final type of system uses local refrigeration equipment and heaters to provide air conditioning. They are called “**unitary refrigerant-based systems**” and we will discuss them in more detail in Chapter 6.

The window air-conditioner is the simplest example of this type of system. In these systems, ventilation air may be brought in by the unit, by opening windows, or from a central ventilation air system.

The unitary system has local refrigerant-based cooling. In comparison, the other types of systems use a central refrigeration unit to either cool the air-conditioning airflow or to chill water for circulation to local cooling units.

The design, operation and choice of refrigeration equipment is a huge field of knowledge in itself. Refrigeration equipment choices, design, installation, and operating issues are introduced in the ASHRAE course *Fundamentals of Refrigeration*.⁵

System Control

We have not yet considered how any of these systems can be controlled. Controls have become a vast area of knowledge with the use of solid-state sensors, computers, radio, and the Internet. Basic concepts will be introduced throughout this text, with a focused discussion in Chapter 11. For an in-depth introduction to controls, ASHRAE provides the course *Fundamentals of HVAC Control Systems*.⁶

2.5 Choosing an Air-Conditioning System

Each of the four general types of air-conditioning systems has numerous variations, so choosing a system is not a simple task. With experience, it becomes

easier. However, a new client, a new type of building, or a very different climate can be a challenge.

We are now going to briefly outline the range of factors that affect system choice and finish by introducing a process that designers can use to help choose a system.

The factors, or parameters that influence system choice can conveniently be divided into the following groups:

- Building design
- Location issues
- Utilities: availability and cost
- Indoor requirements and loads
- Client issues.

Building Design

The design of the building has a major influence on system choice. For example, if there is very little space for running ducts around the building, an all-air system may not fit in the available space.

Location Issues

The building location determines the weather conditions that will affect the building and its occupants. For the specific location we will need to consider factors like:

site conditions
 peak summer cooling conditions
 summer humidity
 peak winter heating conditions
 wind speeds
 sunshine hours
 typical snow accumulation depths.

The building location and, at times, the client, will determine what national, local, and facility specific codes must be followed. Typically, the designer must follow the local codes. These include:

Building code that includes a section on HVAC design including ventilation.
Fire code that specifies how the system must be designed to minimize the start and spread of fire and smoke.
Energy code that mandates minimum energy efficiencies for the building and components. We will be considering the *ASHRAE Standard 90.1-2004, Energy Standard for Buildings Except Low-Rise Residential Buildings*,⁷ and other energy conservation issues in Chapter 12.

In addition, some types of buildings, such as medical facilities, are designed to consensus codes which may not be required by local authorities but which may be mandated by the client. An example is The American Institute of Architects *Guidelines for Design and Construction of Hospital and Health Care Facilities*,⁸ which has guidelines that are extremely onerous in some climates.

Utilities: Availability and Cost

The choice of system can be heavily influenced by available utilities and their costs to supply and use. So, if chilled water is available from the adjacent building, it would probably be cost advantageous to use it, rather than install new unitary refrigerant-based units in the new building.

Then again, the cost of electricity may be very high at peak periods, encouraging the design of an electrically efficient system with low peak-demand for electricity. We will be introducing some of the ways to limit the cost of peak-time electricity in our final chapter, Chapter 13.

The issues around electrical pricing and usage have become very well publicized in North America over recent years. The ASHRAE course, *Fundamentals of Electrical Systems and Building Electrical Energy Use*,¹⁰ introduces this topic.

Indoor Requirements and Loads

The location effects and indoor requirements provide all the necessary information for load calculation for the systems.

The thermal and moisture loads – Occupants' requirements and heat output from lighting and equipment affect the demands on the air-conditioning system.

Outside ventilation air – The occupants and other polluting sources, such as cooking, will determine the requirements.

Zoning – The indoor arrangement of spaces and uses will determine if, and how, the system is to be zoned.

Other indoor restrictions may be very project, or even zone specific. For example, a sound recording studio requires an extremely quiet system and negligible vibration.

The methods of calculating the heating and cooling loads are fully explained, with examples, in the ASHRAE course *Fundamentals of Heating and Cooling Loads*.⁹

Client Issues

Buildings cost money to construct and to use. Therefore, the designer has to consider the clients' requirements both for construction and for in-use costs. For example, the available construction finances may dictate a very simple system. Alternatively, the client may wish to finance a very sophisticated, and more expensive system to achieve superior performance, or to reduce in-use costs.

In addition to cost structures, the availability of maintenance staff must be considered. A building at a very remote site should have simple, reliable systems, unless very competent and well-supported maintenance staff will be available.

Clients' approvals may be gained, or lost, based on their own previous experience with other projects or systems. Therefore, it is important for the designer to find out, in advance, if the client has existing preconceptions about potential systems.

System Choice

While all the above factors are considered when choosing a system, the first step in making a choice is to calculate the system loads and establish the

number and size of the zones. Understanding of the loads may eliminate some systems from consideration. For example:

- In warm climates where heating is not required only systems providing cooling need be considered.
- If there are significant variations in operating hours between zones, a system which cannot be shut down on a zone-by-zone basis may not be worth considering.

Typically, after some systems have been eliminated for specific reasons, one needs to do a point-by-point comparison to make a final choice. This is where the system-choice matrix is a very useful tool.

2.6 System Choice Matrix

The matrix method of system choice consists of a list of relevant factors that affect system choice and a tabular method of comparing the systems under consideration.

Figure 2-16 provides an illustration of the matrix method of choosing a system. In the left column of the matrix are the relevant factors that will be used to evaluate the systems, and the top row shows the systems under consideration.

In our example, we have simplified the matrix in both dimensions. We have strictly limited our relevant factors, and we have limited our choices down to two systems, the reheat system and a VAV system. Note that in a real matrix you would include all the relevant issues, as discussed in the preceding section. You would also probably have several systems under consideration.

In this example, the relevant design issues for this building are as follows:

- The building requires cooling but no heating.
- Some areas of the building will be in use for 24 hours every day of the week. Other areas will be used just during the day, Monday to Friday.
- The client has indicated that operational expenses (ongoing) are more important than construction costs (one time).

| | | System 1 Reheat | | System 2 Variable Air Volume | |
|-----------------------|---------------------|----------------------|----------------|---------------------------------|----------------|
| | Relative Importance | Relative Performance | Relative Score | Relative Performance | Relative Score |
| Cooling Capacity | 8 | 10 | 80 | 10 | 80 |
| Temperature Control | 9 | 10 | 90 | 8 | 72 |
| Zone Occupancy Timing | 10 | 1 | 10 | 9 | 90 |
| First Cost | 5 | 7 | 35 | 5 | 25 |
| Operating Cost | 8 | 3 | 24 | 8 | 64 |
| | | Totals | 239 | | 331 |

Figure 2-16 Matrix for Systems Choice

As you can see, the matrix has a list of relevant issues down the left hand side. Each issue may have a greater or lesser importance. In the column headed “Relative importance” one assigns a multiplier between 1 and 10, with 10 meaning “extremely important” and 1 meaning “not important.” So if, for our example, temperature control is very important it might be rated “9” and the ability to Zone—which is critical to economic operation in this particular building, requires a relative importance of 10. As you can see in the matrix, it is possible for two factors to share the same relative importance.

Once the relative importances have been assigned, it is time to assess the systems under consideration. In our example, both systems have excellent cooling capacity. They each score “10” under performance for this factor.

When we consider the requirement for zone occupancy-timing, however, we note that the reheat system does not have any ability to shut off one part of the system and leave another running. Therefore, it scores only “1” for this requirement. The VAV system, on the other hand, has the capacity to shut off any zone at any time though the main fan still has to run, even if only one zone is on. Therefore the VAV system scores “9” for this factor.

The VAV system also gets a higher score for first cost (construction cost) and for operating expense.

After each factor has been considered, the “relative performance” number is multiplied by the “relative importance” multiplier, to obtain the relative score for that item. The results for each system are totaled, and compared.

In this example, the VAV has a higher score and would be chosen.

The method is an excellent way of methodically assessing system alternatives. However, it should be used intelligently. If a system fails on a critical requirement, it should be eliminated, even if its total score may be the highest. For example, on a prison project, one would likely exclude any system that requires maintenance from the cells, regardless of how high it scored on a matrix!

For a more complete listing of issues for use in a matrix see Chapter 1 of the *2004 ASHRAE Handbook—Systems and Equipment*,¹¹ and for information on operating and other costs see Chapter 35 in the *2003 ASHRAE Handbook—Applications Handbook*.¹²

The Next Step

Having introduced systems and the range of design issues, the next two chapters will cover two specific subjects which dictate design requirements: **Thermal Comfort** in Chapter 3, and **Ventilation and Indoor Air Quality** in Chapter 4.

Summary

2.2 The Psychrometric Chart

The psychrometric chart is a visual aid that demonstrates the relationships of air temperature, moisture content, and energy. It is built upon three simple concepts:

Indoor air is a mixture of dry air and water vapor.

At any given temperature, there is a maximum amount of water vapor that the mixture can sustain. The saturation line represents this maximum. When moist air is cooled to a temperature below the saturation line, the water vapor condenses, and the air is dehumidified. The addition of water to air is called humidification. This occurs when water absorbs energy, evaporates into water vapor and mixes with air. Humidification can take place when water is heated, to produce steam that mixes into the air, or when water evaporates into the air. Evaporation occurs with no external addition or removal of heat. It is called an "adiabatic process." The energy that the water vapor absorbs as it evaporates is referred to as its "latent heat."

There is a specific amount of energy in the dry air/water vapor mixture at a specific temperature and pressure. The energy of this mixture, at a particular pressure, is dependent on two measures: the temperature of the air, and the quantity of water vapor in the air. The total energy of the air/water vapor mixture is called "Enthalpy." The unit measure for enthalpy is kilojoules per kilogram of dry air, abbreviated as kJ/kg.

2.3 The components of a Basic Air-Conditioning System

These include the outside air damper, the mixing chamber, the filter, the heating coil, the cooling coil, the humidifier and the fan. These components are controlled to achieve six of the seven air-conditioning processes: heating, humidifying, cooling, dehumidifying, ventilating, and cleaning.

The economizer cycle is an energy saver for climates with long periods of cool weather. The economizer consists of three, or four additional components: expanded air intake and damper sized for 100% flow; relief outlet with damper to exhaust excess air to outside; return air damper to adjust the flow of return air into the mixing chamber; (optional) return fan in the return air duct.

2.4 Zoned Air-Conditioning Systems

Zoning is used to provide variable heating or cooling in different spaces using: all-air systems, like reheat and variable air volume systems; air-and-water systems, all-water systems, and unitary, refrigeration-based systems.

2.5 Choosing an Air-Conditioning System

Design factors for choosing an air-conditioning system include: building design, location issues, utilities – availability and cost, indoor requirements and loads, and client issues.

2.6 System Choice Matrix

To determine the relative importance of the different design factors, you can use a System Choice Matrix to compare the systems that are under consideration.

Bibliography

1. ASHRAE. 1998. *Fundamentals of Thermodynamics and Psychrometrics*. Atlanta: American Society of Heating, Refrigerating and Air-Conditioning Engineers, Inc.
2. ASHRAE. 1998. *Fundamentals of Air System Design*. Atlanta: American Society of Heating, Refrigerating and Air-Conditioning Engineers, Inc.
3. ASHRAE. 1998. *Fundamentals of Heating Systems*. Atlanta: American Society of Heating, Refrigerating and Air-Conditioning Engineers, Inc.
4. ASHRAE. 1998. *Fundamentals of Water System Design*. Atlanta: American Society of Heating, Refrigerating and Air-Conditioning Engineers, Inc.
5. ASHRAE. 1999. *Fundamentals of Refrigeration*. Atlanta: American Society of Heating, Refrigerating and Air-Conditioning Engineers, Inc.
6. ASHRAE. 1998. *Fundamentals of HVAC Control Systems*. Atlanta: American Society of Heating, Refrigerating and Air-Conditioning Engineers, Inc.
7. ASHRAE. 2004. *ASHRAE Standard 90.1-2004, Energy Standard for Buildings Except Low-Rise Residential Buildings*. Atlanta: American Society of Heating, Refrigerating and Air-Conditioning Engineers, Inc.
8. AIA. 2001. *Guidelines for Design and Construction of Hospital and Health Care Facilities*. Washington, D.C.: The American Institute of Architects.
9. ASHRAE. 1998. *Fundamentals of Heating and Cooling Loads*. Atlanta: American Society of Heating, Refrigerating and Air-Conditioning Engineers, Inc.
10. ASHRAE. 1998. *Fundamentals of Electrical Systems and Building Electrical Energy Use*. Atlanta: American Society of Heating, Refrigerating and Air-Conditioning Engineers, Inc.
11. ASHRAE. 2004. *2004 ASHRAE Handbook—HVAC Systems and Equipment*. Atlanta: American Society of Heating, Refrigerating and Air-Conditioning Engineers, Inc.
12. ASHRAE. 2003. *2003 ASHRAE Handbook—HVAC Applications*. Atlanta: American Society of Heating, Refrigerating and Air-Conditioning Engineers, Inc.