

Chapter 8

Hydronic Systems

Contents of Chapter 8

Instructions

Objectives of Chapter 8

8.1 Introduction

8.2 Natural Convection and Low Temperature Radiation Heating Systems

8.3 Panel Heating and Cooling

8.4 Fan Coils

8.5 Two-Pipe Induction Systems

8.6 Water Source Heat Pumps

The Next Step

Summary

Bibliography

Instructions

Read the material of Chapter 8. Re-read the parts of the chapter that are emphasized in the summary and memorize important definitions.

Objectives of Chapter 8

Chapter 8 introduces hydronic systems, which are also known as water systems. **Hydronic systems**, in this text, are systems that use water or steam as the heat transfer medium. In some places, the term “hydronic” has become associated with just radiant floor heating systems, which is a narrower definition than we are using in this text. We will discuss radiant floor heating systems in Section 8.3, “Panel Heating and Cooling.”

Hydronic systems have their own characteristics, benefits and challenges. After studying the chapter, you should be able to:

Describe five types of hydronic systems

Explain the main benefits of hydronic systems

Discuss some of the challenges of hydronic systems

Explain the operation and benefits of a water-source heat pump system.

8.1 Introduction

In the previous two chapters, we discussed single zone and multiple-zone all-air air-conditioning systems. In Chapter 7, Section 7.2, we mentioned that water coils could be used in the main airhandling unit and for the reheat coils in the reheat and VAV systems. In this chapter we are going to consider systems where water-heated and/or water-cooled equipment provide most of the heating and/or cooling.

In some buildings, these systems will use low-pressure steam instead of hot water for heating. The performance is generally similar to hot water systems, with higher outputs due to the higher temperature of the steam. However, control in these steam systems is generally inferior, due to the fixed temperature of steam. For steam systems and boilers, see Chapters 10 and 27, respectively, of the 2000 *ASHRAE Handbook—Systems and Equipment*. The properties of steam, the theory of two-phase flow and steam pipe sizing, are covered in Chapters 6, 4, and 35 of the 2001 *ASHRAE Handbook—Fundamentals*.

Throughout the rest of this chapter, we will assume that hot water is being used as the heating medium.

Because of their ability to produce high output on an “as-needed basis,” hydronic systems are most commonly used where high and variable sensible heating and/or cooling loads occur. These are typically

- Perimeter zones, with high solar heat gains or
- Perimeter areas in cooler to cold climates where there are substantial perimeter heat losses.

The entrance lobby of a building in a cold climate is an example of an ideal use for these systems. They are frequently used in office buildings, hospitals, hotels, schools, apartment buildings and research laboratories in conjunction with ventilation and cooling air systems.

Hydronic systems advantages:

- Noise reduction—Virtually silent operation
- Economy, due to limited operational costs—Large amounts of heat from small local equipment
- Economy due to limited first costs—Pipes are small compared to ducts for the same heat transfer around a building
- Energy efficiency—Low energy consumption at low load.

Hydronic systems disadvantages:

- Ventilation—Provision of outside air for ventilation is either absent or poor
- System failure—Danger from freezing and from leaks
- Humidity—Control is either absent or generally poor.

We will start our discussion with simple heating systems that operate by allowing heat to escape from a hot surface by natural convection and low temperature radiation.

8.2 Natural Convection and Low Temperature Radiation Heating Systems

The simplest water heating system consists of pipes with hot water flowing through them. The output from a bare pipe is generally too low to be effective, so an extended surface is used to dissipate more heat. There is a vast array of heat emitters. A small selection of types is shown in *Figures 8-1* and *8-2*. Note that there are regional variations both in styles available and popularity. For example, the hot-water panel-radiator is popular in Europe for both domestic and commercial heating systems. In North America, variations on the finned-tube radiator are most popular. The panel radiator shown in *Figure 8-1* is manufactured in a range of heights, from 200 to 900 mm, and in lengths up to 2500 mm.

The radiator emits heat by both radiation and convection. The unit temperature is typically below 105°C and is considered “low temperature” as far as radiation is concerned. In the final chapter of this book, we will review higher temperature radiant heaters and their specific characteristics and uses.

Looking at *Figure 8-2*, we see the classic sectional radiator on the left. Originally made from cast iron, there are now pressed-steel versions being manufactured. All of these terminal units are closed systems that heat the room-air as it contacts the heated coils.

The convector is a coil, mounted horizontally, at the bottom of a casing. The casing is open at the bottom and has louvers near, or in, the top. The coil heats the air, which becomes less dense and rises above the unit. The column of

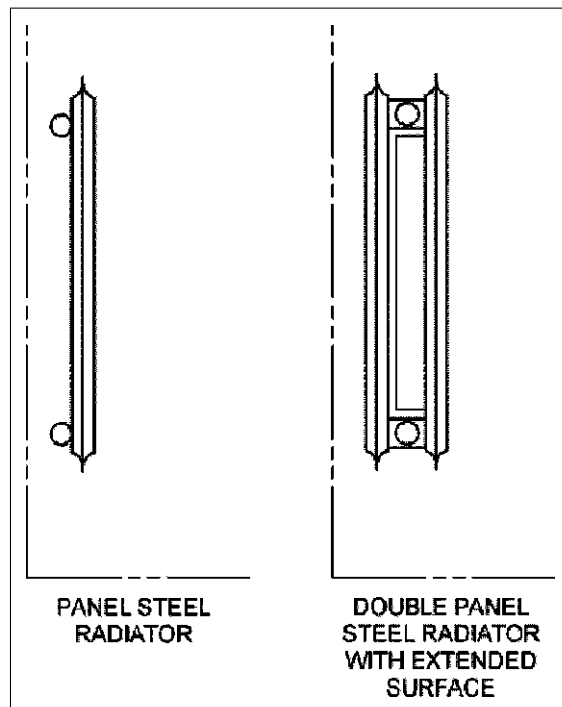

Figure 8-1 Wall-Mounted Single And Double Panel Radiators

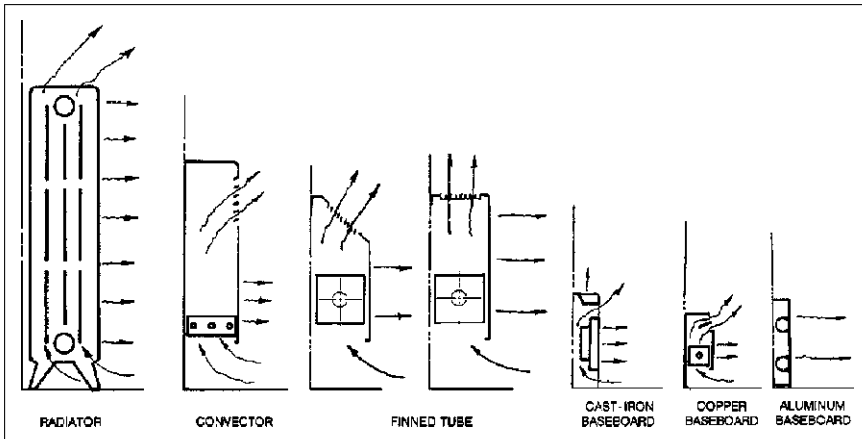

Figure 8-2 Terminal Units

warm, less dense air causes a continuous flow over the coil, convecting heat from the unit. This warm air, rising in an enclosure, is called the “chimney effect,” since it is most often experienced in the draft up a chimney. The taller the chimney, or in this case the taller the casing, the greater the draft through the unit, and the higher the output.

Convectors are typically used where medium output is required in a short length of wall.

The finned tube is similar to the convector, but the unit is long, and typically runs around the perimeter of the building. The hot water enters one end and cools as it flows through the finned tube. If the fins on the tube are at a constant spacing, the output will fall as the water cools down. This drop in output can be offset, to some extent, by having sections of pipe with no fins at the hot end and also by changing the fin spacing along the tube.

Since the output occurs along the length of the unit, it nicely balances the heat loss through walls and windows, providing a thermally comfortable space without downdrafts. The construction is normally lightweight, so if the finned tube is to be installed where someone may sit or stand upon it, a more robust version should be chosen. Some designs permit limited, manual adjustment to the output, accomplished by setting a flap damper in the unit.

The copper baseboard radiator is a small residential version of the finned tube. Cast iron baseboards have the advantage of being robust, however low output and substantial material make them less popular nowadays. Finally, the aluminum baseboard unit consists of pipes bonded to an aluminum sheet that emits almost all its heat by radiation, with a consequently low output.

These water heaters can all be controlled in two ways:

- By varying the water flow
- By varying the water supply temperature.

Varying the water flow: Local zone control can be achieved by throttling the water flow. The simplest way to achieve this is with a self-contained control valve, mounted on the pipe. This valve contains a capsule of material that experiences large changes in volume, based on room temperature. As the temperature rises, the material expands and drives the valve closed. The valve settings are not marked with temperatures and it is a matter of trial-and-error

to find the comfortable setting. A better, but more expensive, method of control is a wall thermostat and water control valve.

Control by modulating, or adjusting, the water flow works best when the load is high and the flow is high. For example, a finned tube, operating at low load with a low flow, will have almost full output just at the entry point of the water, but the water cools down to provide no output of heat at the far end. Both this issue and unnecessary pipe losses can be greatly reduced by modulating the water temperature.

Varying the water temperature: The heat loss through a wall or window is proportional to the temperature difference across the wall or window. Thus, one can arrange a control system to increase the water temperature as the outside temperature falls, so that the heat output from the water will increase in step with the increase in heating load. This control system is called **outdoor reset**. In a simple outdoor reset system, the water flow temperature might be set to 80°C at the anticipated minimum outside design temperature, dropping to 20°C at an outside temperature of 20°C.

The output from the heater is not exactly linearly proportional to the water temperature. The actual output rises proportionately faster, the higher the temperature difference between heater and space. This disparity does not matter if the zone thermostat controls the zone temperature.

Outdoor reset:

- Minimizes uncontrolled heat loss from distribution piping.
- Improves zone control by keeping the zone flow control valves operating near full capacity.
- Achieves a more even temperature in the heaters, since the flow stays up.

Together, outdoor reset of water supply temperature and zone throttling provide excellent temperature control of hydronic systems.

Meeting Ventilation Requirements

These hydronic heating systems do not provide any ventilation air from outside. When water systems are in use, ventilation requirements can be met in one of 3 ways:

- Open windows
- Window air conditioners
- Separate ventilation systems with optional cooling.

Open Windows: Water systems are often used with occupant-controlled windows (opening windows) where the room depth is limited and the outdoor temperatures make it practical to open windows.

Window Air conditioners: One step up from heating and opening windows is heating and the window air-conditioner.

Separate ventilation systems with optional cooling: The alternative is to install a separate system to provide ventilation and, if needed, cooling. This is a very common design in cooler climates for two reasons. First, the water heating around the perimeter is very comfortable and, second, it means that the air system can be shut off when the building is unoccupied, leaving the heating operating and keeping the building warm. Many office buildings operate only five days a week, twelve hours a day, so the air system can be turned off for 108 hours and only run 60 hours a week, saving 64% of the running hours

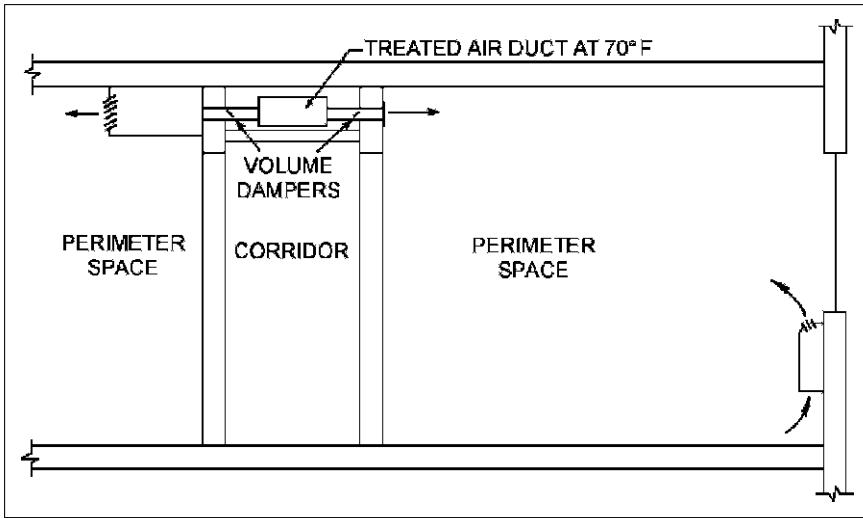

Figure 8-3 Ventilation from a Separate Duct System

of the ventilation system. *Figure 8-3* shows perimeter fan coils which provide heating and cooling, plus a ventilation system using the corridor ceiling space for the ventilation supply duct.

The control of the hydronic heating system and ventilation/cooling system should be coordinated to avoid energy waste. Assume for a moment that each system has its own thermostat in each zone. If the heating thermostat is set warmer than the cooling thermostat, both systems will increase output until one is running flat out. Therefore, it is important to have a single thermostat controlling both the water heating system and the air-conditioning system. Ideally, this thermostat will have a **dead band**, which is a temperature range of, say, 1°C between turning off the cooling and turning on the heating.

In hot moist climates, the primary ventilation air must be supplied with a low moisture content to minimize mold problems. In addition, it is advantageous to keep the building pressure positive with respect to outside, so as to minimize local infiltration that might cause excessive moisture inside.

8.3 Panel Heating and Cooling

The floor or ceiling of the space can be used as the heater or cooler. A floor that uses the floor surface for heating is called a **radiant floor**, see *Figure 8-4*.

The radiant floor is heated by small-bore plastic piping that snakes back and forth at even spacing over the entire area that requires heating. The output can be adjusted from area to area by adjusting the loop spacing, typically 150 to 450 mm, and circuiting the pipe loop. Typically the water is supplied first to the perimeter, to produce the higher output at the perimeter.

The acceptable floor surface temperature for occupants' feet limits the output. You may remember from Section 3.4, on human comfort, that ASHRAE Standard 55 limited the floor temperature to a range of 19–29°C for people wearing shoes who were not sitting on the floor. The maximum temperature limits the amount of heat that can be provided by a radiant floor.

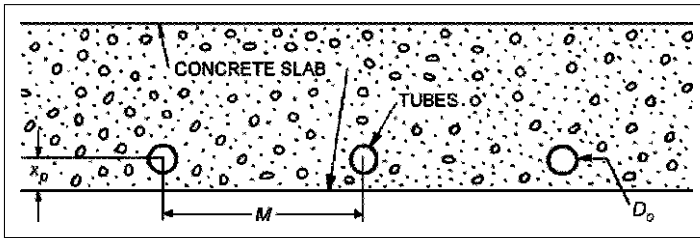

Figure 8-4 Concrete Radiant Floor

Though radiant floors are often more expensive to install than other forms of heating, they can be very effective and economical to run, since they do not generate significant thermal stratification. As a result, the system is very comfortable and ideal for children and the elderly. Control is usually achieved by outdoor reset of water temperature and individual thermostats for each zone.

The system can also be installed in outside pavement by using an inhibited glycol (antifreeze) mixture instead of plain water. This can be used to prevent icing of walkways, parking garage ramps and the floor of loading bays that are open to the weather.

Ceilings can also be used for heating and/or cooling. As noted in Section 3.4, when using ceilings for heating, care must be taken to avoid radiating too much heat onto occupants' heads. For ceilings down at 3 meters, the maximum temperature is 60°C. This maximum rises to 82°C at 5.5 meters ceiling height. When cooling, you circulate chilled water, instead of hot water through the ceiling panel pipe. The water temperature must be kept warm enough to ensure that condensation problems do not occur. The temperature difference between the ceiling panel and the space is quite limited. This limits the cooling capacity of the ceiling system and effectively limits its use to spaces that do not have high cooling loads.

Typically, a metal ceiling tile has a metal water pipe bonded to it, so that the whole surface becomes the heat emitter. There are many designs; one is shown in *Figure 8-5*.

The system has the advantage of taking up no floor or wall space and it collects no more dirt than a normal ceiling, making it very attractive for use in hospitals and other places that must be kept very clean.

8.4 Fan Coils

Up to now, the systems we have considered are passive (no moving parts) heating and cooling systems. We will now consider fan coils. As their name suggests, these units consist of a fan and a coil. Fan coils can be used for just heating or for both heating and cooling. In heating-only fan coils, the heating coil usually has fairly widely spaced fins so a lint filter is not critical. In dusty, linty environments, this may necessitate occasional vacuuming of the coil to remove lint buildup. Fan coils can be mounted against the wall at the ceiling. A typical fan-coil unit is illustrated in *Figure 8-6*.

When the fan-coil is used for heating, the hot water normally runs through the unit continuously. Some heat is emitted by natural convection, even when the fan is "off." When the thermostat switches the fan "on," full output is achieved. A thermostat within the unit works well in circulation areas, such

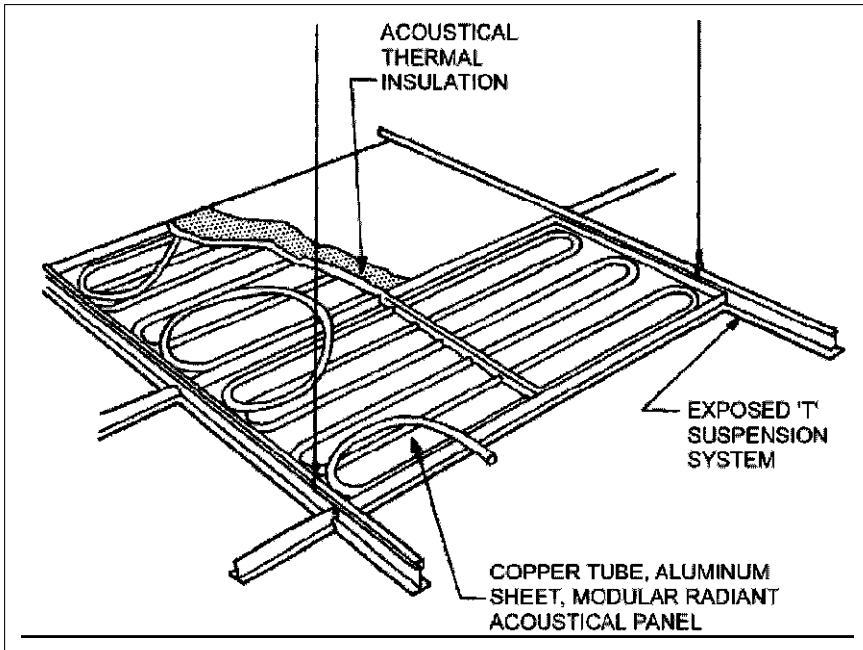

Figure 8-5 Example of Ceiling Radiant Panels

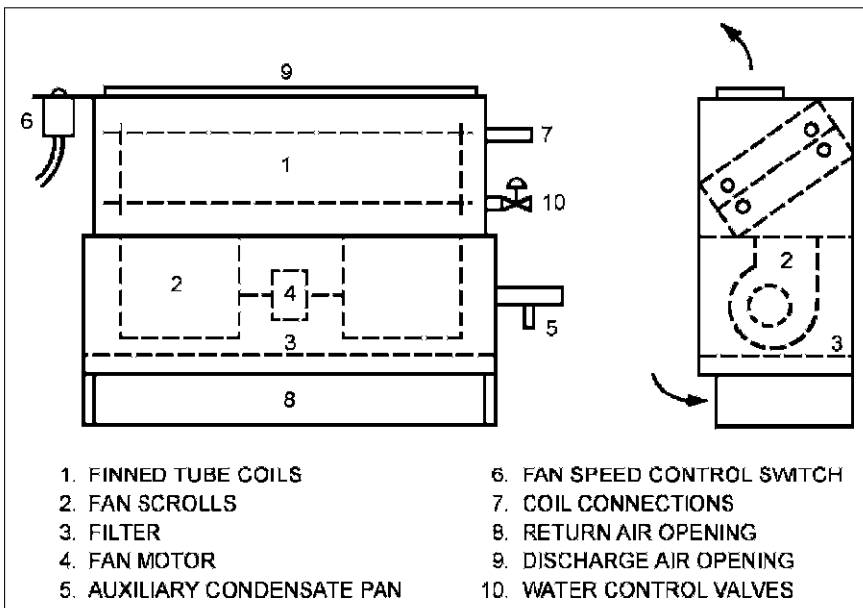

Figure 8-6 Typical Fan-Coil Unit

as entrances and corridors, where temperature control is not critical, and temperature differential is large. Generally, in occupied spaces, a room thermostat should be used to control the unit, to provide more accurate control.

Some units are provided with two or three speed controls for the fan, allowing adjustment in output of heat and generated noise. Many designers will choose a unit that is designed to run at middle speed, to minimize the noise from the unit. Another way to minimize noise from the unit is to mount the unit in the ceiling space in the corridor and duct the air from the unit into the room.

Hot-water fan coils. These are an ideal method of providing heat to the high, sporadic, loads in entrances. In cold climates, if the outside door does not close, the unit can freeze, so it is wise to include a thermostat that prevents the fan from running if the outflow water temperature drops below 50°C. Fan-coils may be run on an outdoor-reset water system, but this limits their output and keeps the fan running more than if a constant, say 30°C, water temperature is supplied to the unit.

Changeover system. The same fan coil can be used for heating or for cooling, but with chilled water instead of hot water. This is called a changeover system. If a coil is used for cooling, it can become wet, due to condensation, and so it requires a condensate drain. The drain requires a slope of 10 mm per meter, to ensure that the condensate does not form a stagnant pool in the condensate pan. Failure to provide an adequate slope can result in mold growth and consequent indoor air quality, IAQ, problems. For ceiling-mounted units, providing an adequate slope for the drain can be a real challenge.

If the coil is designed to run dry, with no condensation, then a filter is not absolutely necessary. However, if the coil may run wet, it must be protected with a filter with efficiency minimum efficiency reporting value (MERV) of not less than 6 when rated in accordance with ANSI/ASHRAE Standard 52.2, to minimize lint and dust buildup on the coil. Both the filter and the drain require regular maintenance and therefore access to the unit must be available.

Timing is the challenge of changeover systems: when to change over from heating to cooling and vice versa. For manual changeover systems, the spring and fall can create real headaches for the operator. The system needs to be heating at night but cooling for the afternoon. The question for the operator is "What time should the change occur?" The challenge can be reduced if there is a ventilation system with temperature control. When it is cool outside, the ventilation air is supplied cool, thereby providing some cooling. When it is warm outside, the ventilation air is supplied warm and that will provide a little heating.

Generally, the operator will choose a day and change the system over, so that the spaces are either excessively warm in the afternoon or cool in the morning. The advent of computerized controls has enabled designers to include sophisticated automatic programs that deal with the changeover issue far more effectively than through manual operation.

Four-Pipe system: As an alternative design to a changeover system, the unit can include two coils, heating and cooling, each with its own water circuit. This is called a four-pipe system, since there are a total of four pipes serving the two coils. This system is more expensive to install but it is a more efficient system that completely avoids the problem of timing for change over from heating to cooling.

The four-pipe fan-coil system is ideal for places like hotels, where rooms may be unoccupied for long periods. The temperature can be allowed to drift

well above or below the comfort level, since the fan-coil has enough output on full-speed to quickly bring the room to a comfortable temperature. Once the comfortable temperature is achieved, the occupant can turn the unit down to a slower speed so that the temperature is maintained with minimal fan noise.

8.5 Two-Pipe Induction Systems

When air moves through a space with speed, additional air from the space is caught up in the flow, and moves with the flow of the air. When this occurs, the room air that is caught up in the flow is called **entrained air**, or **secondary air**.

The two-pipe induction system (Figure 8-7) uses ventilation air at medium pressure to entrain room air across a coil that either heats or cools. The ventilation-air, called **primary air**, is supplied at medium pressure and discharged through an array of vertical-facing nozzles. The high-velocity air causes an entrained flow of room air over the coil and up through the unit, to discharge into the room. The flow of room air through the unit has little energy, so obstructing the inlet or the outlet with furniture, books, etc., can seriously reduce the performance of the unit.

The coil in the induction unit is heated or cooled by water. For cooling, the coil should be designed to run dry, but it may run wet, so a condensate tray is normally necessary. In a hot, humid climate, to minimize the infiltration of moist air and reduce the likelihood of the coil running wet, the building pressure should be maintained positive. A lint filter should be provided to protect the coil. This filter will need to be changed regularly, so good access to the front of the unit is required.

The induction unit produces some noise due to the high nozzle velocity. This makes it less suitable for sleeping areas. The air noise is tone-free,

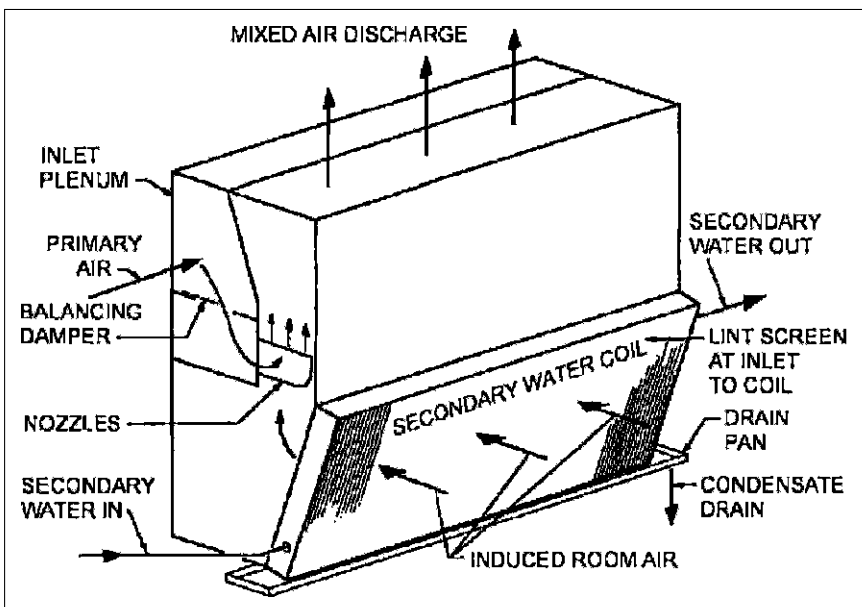

Figure 8-7 Induction Unit

though, and thus not annoying in most occupied spaces if silence is not a prerequisite.

The units are typically installed under a window, and when the air system is turned off the unit will provide some heat by natural convection, if hot water is flowing through the coil.

8.6 Water Source Heat Pumps

Water source heat pumps are reversible refrigeration units. The refrigeration circuit is the one we considered in Chapter 6, *Figure 6-6* except that one coil is water cooled/heated instead of air cooled/heated. The heat pump can either transfer heat from water into the zone or extract heat from the zone and reject it into water. This ability finds two particular uses in building air conditioning:

- The use of heat from the ground
- The transfer of heat around a building.

The use of heat from the ground

There is a steady flow of heat from the core of the earth to the surface. As a result, a few meters below the surface, the ground temperature remains fairly steady. In cool climates, well below the frost line, this ground heat temperature may be only 5°C, but in the southern United States it reaches 21°C. This constant temperature can be utilized in two ways. Where there is groundwater available, two, properly distanced, wells can be dug and the water pumped up and through a heat pump. The heat pump can cool the water and heat the building or, in reverse, heat the water and cool the building.

Where the water is too corrosive to use, or not available, water filled coils of plastic pipe can be laid in the ground in horizontal or vertical arrays to absorb heat from, or dissipate heat into, the ground. This use of heat from the ground by a heat pump is commonly called a “ground-source heat pump.”

The ground-source heat pump provides relatively economical heating or cooling using electricity. The ground-source heat pump has a much higher cooling efficiency than an air-cooler air-conditioning unit, making it very attractive in areas where the summer electricity price is very high or supply capacity is limited. In places where other fuels for heating are expensive, the ground-source heat pump can be very attractive.

The transfer of heat around a building

The second use of heat pumps in building air conditioning is the water loop heat pump system. Here each zone is provided with one or more, heat pumps, connected to a water pipe loop around the building, see *Figure 8-8*. The water is circulated at 15°C to 33°C and the pipe is normally not insulated. Each zone heat pump uses the water to provide heating or cooling as required by that zone.

As you can see in *Figure 8-8*, there is a boiler to provide heating and a cooling tower to reject heat when the building has a net need for heating or cooling. The boiler, or tower, is used when required to maintain the circulation water within the set temperature limits. The system provides local heating or cooling at any time and each heat pump can be scheduled and controlled independently.

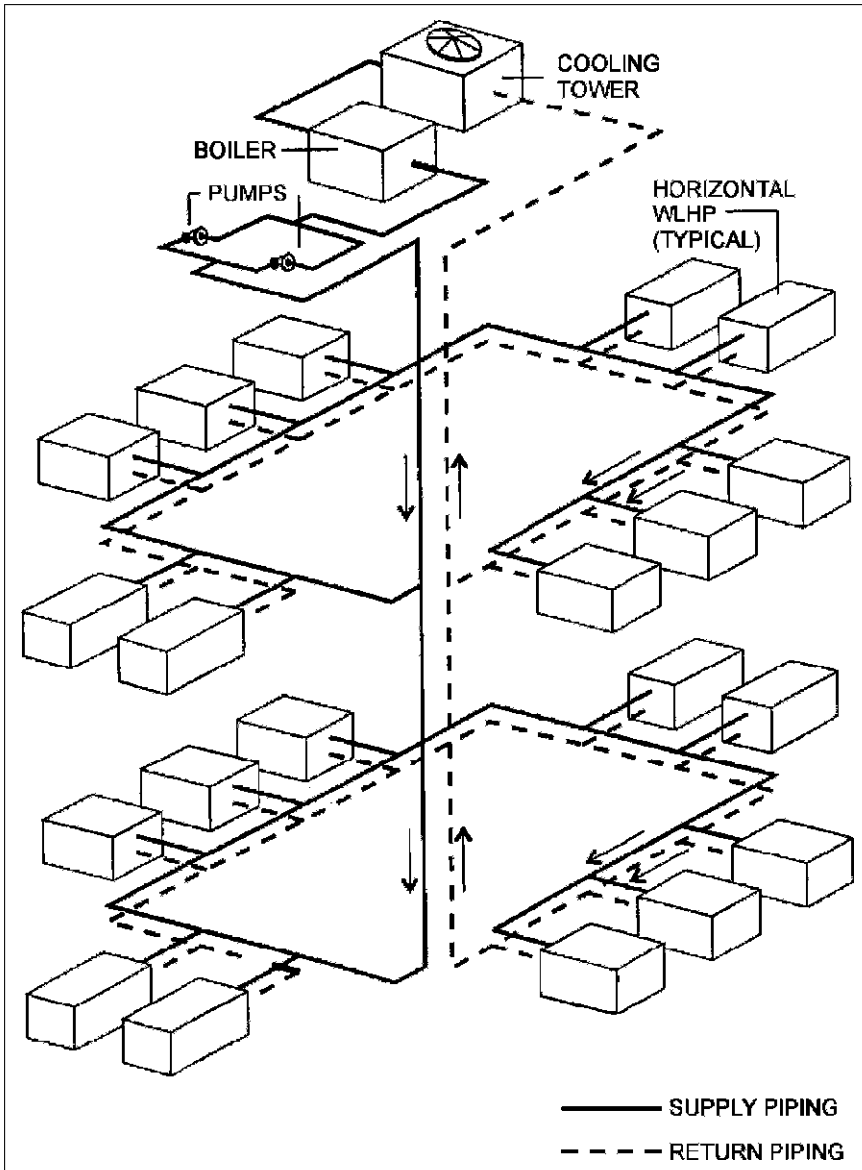

Figure 8-8 Heat Recovery System Using Water-to-Air Heat Pumps in a Closed Loop

The question is: “why would anyone design a system that required so much equipment in a building?”

- In many buildings there are significant interior spaces that always require cooling, due to the heat from occupants, lighting, and equipment. This heat is put into the water loop and can then be used in exterior zones for heating.
- In addition, there are often times when the solar heat gain on the south side of a building requires zone cooling when the sun shines, while the north side of the building still requires heating.

- Lastly there are buildings with significant heat generation equipment, such as computer rooms, server racks, and telephone equipment, where the waste heat from these operations can be used to heat the rest of the building.

The heat pump units require regular filter changes to ensure that airflow is maintained, since they each include a direct expansion refrigeration circuit. In addition, the water circuiting must be designed to maintain a constant flow through the operating units, even when other units are removed for repair. This issue will come up again when we are discussing water piping in the next chapter, Chapter 9.

These closed loop systems are very effective in multiuse buildings, buildings with substantial core areas and heating loads, and buildings where occupancy is variable in both time and quantity. Examples include offices, hotels, commercial, colleges, and laboratories.

The Next Step

Having considered a variety of hydronic systems in this chapter we will go on in Chapter 9 to consider the pumping, piping, balancing and control of water systems.

Summary

This chapter has covered the more common hydronic systems used in air-conditioning buildings.

8.2 Natural Convection and Low Temperature Radiation Heating Systems

The very simplest water heating systems consist of pipes with hot water flowing through them. The output from a bare pipe is generally too low to be effective, so an extended surface is used to dissipate more heat. The radiator emits heat by both radiation and convection. These water heaters can all be controlled by varying the water flow or by varying the water supply temperature.

These hydronic heating systems do not provide any ventilation air from outside. When water systems are in use, ventilation requirements can be met by opening windows, window air conditioners, or separate ventilation systems with optional cooling.

8.3 Panel Heating and Cooling

Radiant floors use the floor surface for heating. Ceilings can also be used for heating and/or cooling. The system has the advantage of taking up no floor or wall space and it collects no more dirt than a normal ceiling.

8.4 Fan Coils

Fan coils can be used for just heating or for both heating and cooling. When the fan-coil is used for heating, the hot water normally runs through the unit continuously. Some heat is emitted by natural convection, even when the fan is off. When the thermostat switches the fan on, full output is achieved. Some units are provided with two, or three speed controls for the fan, allowing adjustment in output of heat and generated noise. Types of fan coils include: Hot-water fan coils, changeover systems, and four-pipe systems.

8.5 Two-Pipe Induction Systems

The two-pipe induction system uses ventilation air at medium pressure to entrain room air across a coil that either heats or cools. The units are typically installed under a window, and when the air system is turned off, the unit will provide some heat by natural convection if hot water is flowing through the coil.

8.6 Water Source Heat Pumps

Water source heat pumps are refrigeration units that can either pump heat from water into the zone or extract heat from the zone and reject it into water. This ability finds two particular uses in building air conditioning:

1. The use of heat from the ground
2. The transfer of heat around a building.

Bibliography

- ASHRAE. 2000. *2000 ASHRAE Handbook—Systems and Equipment*. Atlanta: American Society of Heating, Refrigerating and Air-Conditioning Engineers, Inc.
- ASHRAE. 2001. *2001 ASHRAE Handbook—Fundamentals*. Atlanta: American Society of Heating, Refrigerating and Air-Conditioning Engineers, Inc.