

CHAPTER 9

Replaceable Filter Elements

To provide an effective filter, the filter medium has to be held in some kind of housing that provides a complete seal between upstream and downstream sides of the medium, and to provide inlet for the feed and exit for the filtrate or permeate. It is convenient in many types of filter to mount the medium on some kind of support structure, which enables it to be taken out of its housing to be cleaned or replaced. It is this replaceable structure, or filter element, that is the subject of this chapter.

9.1 Introduction

Replaceable filter elements may be almost entirely composed of the filter medium, as with the sheets in a sheet filter, or they may be a complex assembly of supporting core, pleated medium (itself perhaps made of several layers, including support and retaining cover), and an outer shield. So long as an element can be changed, whether to discard the old one, or to clean it, then it is covered in this chapter. Some of these elements are made from media that have been discussed in earlier chapters, while others are specially fabricated to achieve a filtration task, without the use of what could be recognized as filter media.

Although the term 'cartridge' has a specific meaning smaller in scope than that of this chapter, it is convenient to use the word as shorthand for 'replaceable filter element'. A filter cartridge in this broader sense is thus any component of a filter that includes the filter medium, and that can be removed from the filter as an integral unit, either for servicing or for replacement by a new, but identical component.

There are two reasons for including a chapter on cartridges in a book overtly devoted to filter media. One is that the immense diversity of commercially available cartridges forms a uniquely important and versatile category of equipment, which collectively utilizes almost the entire range of media described in the preceding chapters. The other is that there are yet further types of filter media that exist only because of the structure of specially fabricated cartridges; a good example is the popular yarn-wound cartridge.

Cartridges provide a very convenient, versatile and often economic way to filter either liquids or gases, provided the concentration of solid or liquid contaminant is low; as a general guide, the concentration of particulates in a liquid should be less than say 0.01% by weight, with the particle size ranging downwards from about 40 μm to submicrometre sizes. If the solids concentration is much larger than this figure, then, unless the medium has a high dirt-holding capability, the service life of the cartridge will be inconveniently short.

In application, cartridges may be used for general clarification, polishing or sterilization. For liquids, most such duties are typically on a small or medium scale, but multiple cartridge units are used for substantial flows in some special applications, such as coalescer filters for aircraft refuelling. Cartridges play a major role in gas filtration at all scales of operation.

9.1.1 Types of cartridge

An important characteristic of a cartridge filter is the type of cleaning action to be taken, manually or automatically, when it becomes fully loaded with collected contaminant, as typically indicated by either an increase in back pressure or decrease of flow rate. In this regard, four categories of cartridge may be distinguished:

- the 'throwaway' or 'disposable' cartridge, which cannot be cleaned and is therefore replaced;
- the 'cleanable-in-place' cartridge, which can readily be cleaned (e.g. by intermittent reverse flow as part of the operating cycle) and reused several or many times, even if eventually it may need to be replaced;
- the 'service-cleanable' cartridge, which must be removed from the filter and subjected to specialized cleaning (e.g. in an ultrasonic bath), either on site or by returning to the manufacturer or to a service company; and
- the 'reclaimable' cartridge, which must be returned to the manufacturer who strips it down and rebuilds it after replacing the filter medium.

To a large extent, the differences between these cartridges result from the nature of the filter medium involved and the filtration mechanism by which it functions. For example, media functioning exclusively by surface straining and/or cake filtration can be easily cleaned. By contrast, depth filtration inevitably involves the trapping of particles within the depth of the medium, whence their removal is likely to be difficult or impossible; on the other hand, depth filtration can provide a relatively large dirt-holding capacity. Equally important, however, may be the exact conditions under which the filter is to be used, as well as the detailed design and construction both of the cartridge and of the filter housing.

So far as the chemical and processing industries are concerned, it is generally only the first two categories that are of practical importance. Examples of the application areas of the other categories are service-cleanable cartridges for the manufacture and processing of polymers and reclaimable cartridges for filters used in high-pressure hydraulic systems.

As cartridges are used to remove solid or liquid contaminants from a fluid flow, it goes almost without saying that they will eventually become too dirty for continued use and must then be cleaned or removed, for which purpose the process fluid flow must be stopped. Where only one filter is in use, such stoppage could cause inconvenience to the process operation. To achieve continuity of flow, therefore, *duplex* filter housings are used, in which two identical cartridge units are mounted side-by-side, so that the fluid flow can be switched from the dirty unit to the clean one, with almost no impact on fluid flow, and the dirty unit then cleaned, ready to take up its duty when required.

Where more than one cartridge is used, then the cleaning process can be operated in rotation, with a reverse flow pulse, for example, applied to individual cartridges, or small groups of them, in turn.

9.1.2 Element disposal

A feature of replaceable elements that is of growing importance is the nature of the materials of construction or, more particularly, the range of materials. Some elements are intended for once-only use, followed by disposal, and all elements eventually reach a point where they can no longer be reused and have to be discarded. Disposal practice increasingly requires material recycle, or disposal by controlled incineration. In either case, the nature of the discarded element could be critical to its ease of disposal, and, in general, the fewer the number of component materials the easier will be the disposal.

Ideally, an element should only have one material of construction, from which all parts of it are made: filter medium, supporting core, end caps, retaining screens, protective covers – everything. This is not easy, especially where a filter medium is a multi-layer material, with different layers doing different jobs, and, therefore, possibly needing to be made from different materials, but all manufacturers are now trying to make single-material elements.

9.2 Cartridges with Conventional Media

The replaceable elements in filters that are made from the media, woven and non-woven, paper, screen and membrane, discussed in preceding chapters, are of three major types:

- the panel (or cassette) used for air conditioning;
- the simple filter bag or pocket; and
- the cylindrically shaped cartridge, made in a variety of structures.

To these should be added the special modular cartridges employed for membrane media.

An essential feature of all of these types of cartridge is the need to maximize operating lifetime, i.e. to maximize the ability of the cartridge to hold the dirt removed from suspension. Especially in the case of surface filtration media, this

need results in maximizing the filter surface area packed into a specific filter volume.

9.2.1 Ventilation filters

The media involved in the replaceable panels used in air conditioning systems are described in detail in Chapter 5. The underlying principles common to the evolution of many commercially available filter cartridges can be illustrated by following the developments in ventilation air filters from the very basic panel illustrated in Figure 9.1. This comprises a flat square sheet of filter medium, usually with retaining screens front and back, mounted within a cardboard frame so that the cartridge can be inserted into a metal support frame. In practice, the filtering material is typically of multi-layered construction, such as an active thick inner layer of synthetic polymer or glass microfibres sandwiched between protective outer coverings of open spunbonded fabric.

So as to increase the available filtering area and thereby to permit a correspondingly larger flow, a logical step from this elementary format is to pleat the filter medium, to give the form shown in Figure 9.2. Deeper and more closely packed pleats, with spacers to maintain a gap between adjacent pleats, as in Figure 9.3, provide yet higher active area for the same superficial face area of a cartridge. Another construction that involves even deeper pleats is the multi-pocket or bag filter shown in Figure 9.4. The types of media utilized in these various constructions are discussed in Chapter 5.

9.2.2 Filter bags

An extremely simple form of cartridge for liquid filtration is a fabric bag in the open filtration system illustrated in Figure 9.5; more usually, these bags are used as inserts in mesh baskets housed in an enclosed vessel, as in Figure 9.6, for operation at differential pressures up to 20 bar or more. Alternatively, the bags may be fitted as sleeves over a supporting cage of mesh or welded rods. The interest in bags for liquid filtration faded when higher efficiencies were

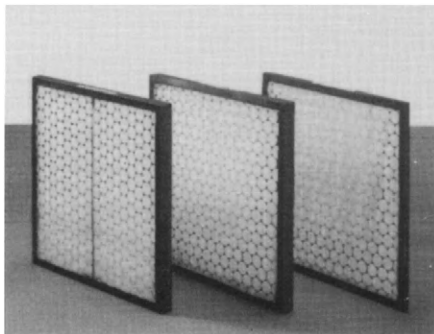

Figure 9.1. Flat panel air ventilation filter cartridges.

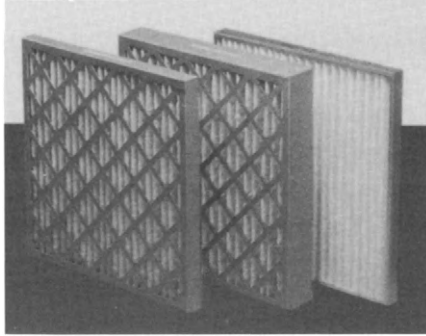

Figure 9.2. Pleated panel air ventilation filter cartridges.

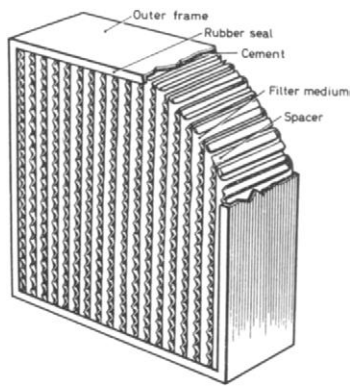

Figure 9.3. A typical high efficiency (HEPA) air filter.

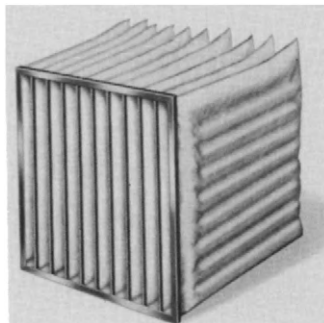

Figure 9.4. Multi-pocket or bag air filter.

demanded because the structure of the bag with a sown longitudinal seam allowed passage of larger particles. Now that manufacturers are able to offer seamless bags, the interest in such elements has returned.

The range of filter bags for liquid filtration offered by the Hayward group is very extensive, now that it includes the old GAF and Loeffler ranges. The products include needlefelt media, multi- and monofilament meshes, and meltblown polypropylene, the last as high efficiency, layered construction, capable of filtration down to 1 μm .

Bags may be of one or more layers, an extreme example of multi-layered construction being 3M's Series 500 bags, which contain 35 seamless layers; these comprise bypass layers with holes in them, transport layers between the

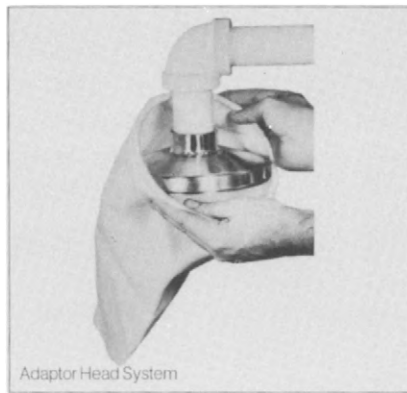

Figure 9.5. Fitting a bag filter to an adaptor head for open filtration.



Figure 9.6. Fitting a bag filter into an enclosed housing.

bypass layers, and finally 15 layers of meltblown microfibres, to achieve high flow rates and dirt-holding capacity at low pressure drops.

The filter bag for gas filtration is mentioned in Chapter 5 as the active element in fabric filters. The BHA Group, one of the world's largest suppliers to the air pollution control sector, supplies filter bags for air and gas filtration, made from polyester, polypropylene, acrylics, glass fibre, Nomex, Ryton, P84, and fluoropolymers. The range includes bags covered in ePTFE (the BHA-TEX range), with a microporous coating of ePTFE on felts or other non-wovens, providing efficiencies of 99.99% or more; the coating can be on the inside or the outside depending upon the direction of gas flow. Bags are made from all of these materials for fabric filters operating with reverse air or shaker mechanisms for dust cake removal, where the dust-laden air flows into the inside of the bag, with dirt collected on the inside, or with pulse jet or plenum pulse removal, where the air flow is from outside-to-in, and dirt collects on the outside of the bag.

A novel form of filter bag is sold by Albany International as its Star-Bag configuration. This uses a fabric bag supported on a cage so made as to allow the bag to take up a pleated shape, offering 1.7–2.4 times the filter area of a normal cylindrical bag. Star-Bags are available in polyester, homopolymer acrylic, polyphenylene sulphide, aramid, polyimide, glass fibre, polypropylene, and PTFE, as needlefelt or woven materials.

9.2.3 Cylindrical cartridges

Contrasting with the rectangular geometry of ventilation filters is the cylindrical form usual for the major family of cartridges both for liquids, and for compressed gases and for the air intakes of engines. Cartridges are also of increasing importance in general gas cleaning applications.

The simplest form of a cylindrical cartridge filter comprises a cylindrical vessel containing a tubular filtering element or cartridge. This may be either sealed at one end or open at both ends but suitably locked within the housing to produce the same results, as shown in Figures 9.7 and 9.8; flow is generally inwards through the wall of the element.

A Y-type or basket in-line strainer, as in Figure 9.9, conforms with this general description, the strainer element typically being formed from relatively coarse woven metal or plastic mesh, or perforated sheet. Strainers are, as their name implies, used for the removal of relatively coarse particles from a liquid stream, especially as prefiltration units ahead of some other more delicate filter or piece of machinery.

The cartridge may be formed of a single layer of medium if the material is sufficiently rigid to be self-supporting, such as sintered metal or wire-wound, or porous ceramic or plastic, of which two examples are shown in Figures 9.7 and 9.10. Media of this kind are discussed more fully in Chapter 7.

Frequently, the cartridge comprises a rigid porous core supporting one or more layers of media, such as woven or non-woven textiles, as in Figure 9.11. Various types of support cores are used, including perforated metal and Netlon-type extruded polymers (Figures 9.12 and 9.13).

9.2.4 *Pleated cylinders*

The active filtration area in a cartridge can be greatly increased by using a tubular core to support pleated media, which can be single or multiple layers of media such as cellulose paper, non-wovens and membranes; the multi-layer assemblies may provide a graded pore structure (e.g. including a prefiltration stage), as well as incorporating layers to aid drainage, support more fragile

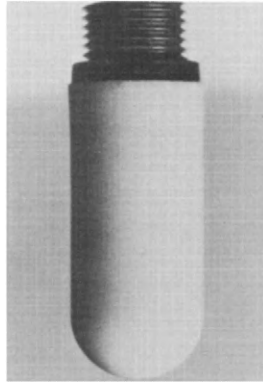

Figure 9.7. A porous plastic filter cartridge, open at one end.

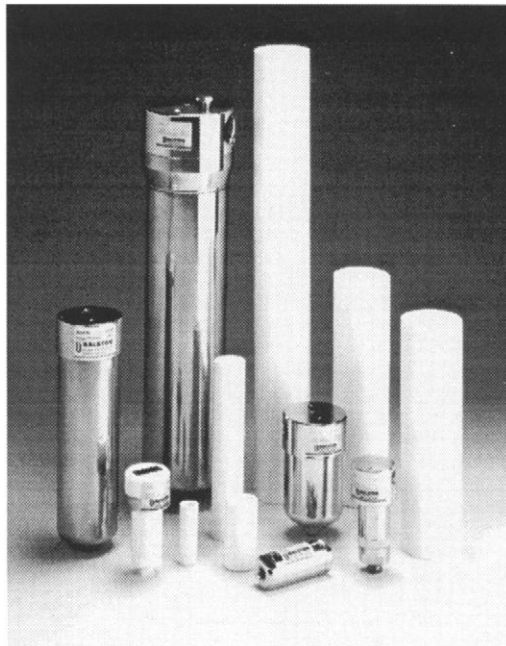

Figure 9.8. Balston glass fibre tubes, both ends open.

media, and act as a protective covering. Pleated cylindrical cartridges are used for both gas and liquid filtration.

A typical design is that supplied by Freudenberg in its TFP 60 range. This is a depth filtration cartridge, using a graded felt of synthetic fibres, the fibres being finer and more densely laid in the direction of gas flow. The TFP 60 P66 P2 is 660 mm long, 327 mm in outside diameter, with its pleats held on a plastic mesh core. The resultant filtration area is 3 m^2 , the initial pressure drop at $1000 \text{ m}^3/\text{h}$ being 150 Pa, the recommended final pressure drop being 800 Pa, at which point the dust capacity (AC Fine) is 1.2 kg.

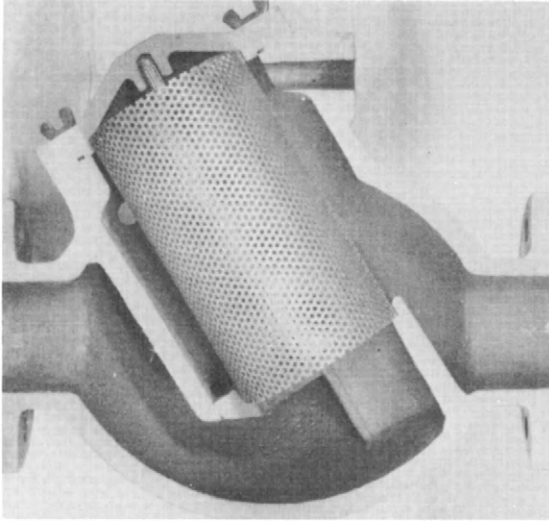

Figure 9.9. A typical pipeline Y-strainer

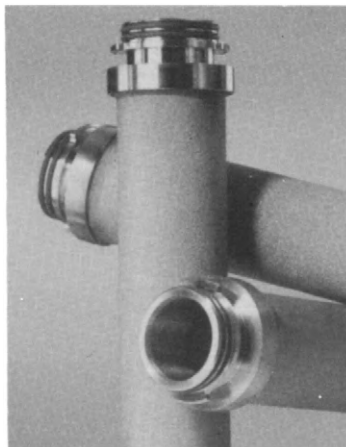

Figure 9.10. Sintered stainless steel filter cartridges.

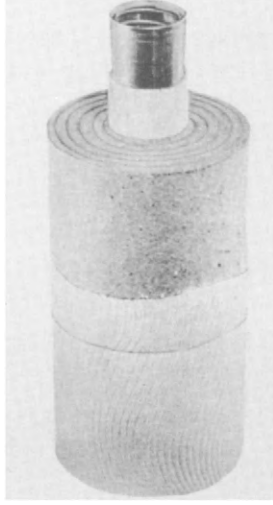

Figure 9.11. Cartridge formed by winding layers of felt around a metal former.

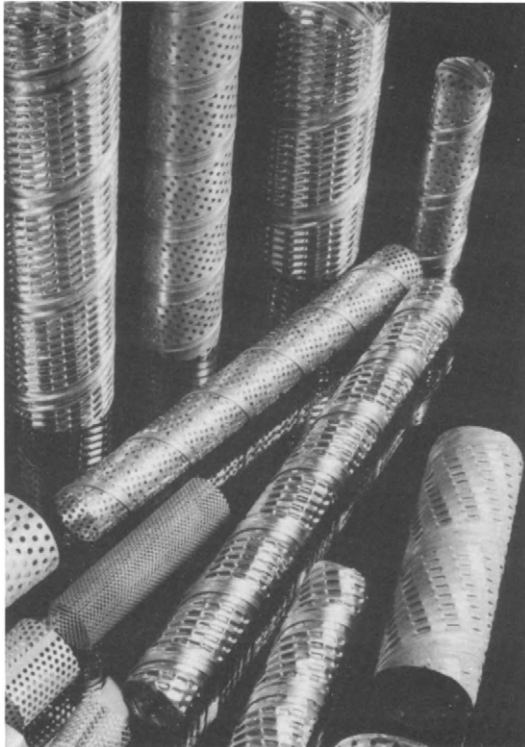

Figure 9.12. Perforated metal tubes as cores for filter cartridges.

9.2.4.1 Pleated cartridges for liquids

Typical examples of liquid filtration cartridges are the fuel and lubricating oil felt filter in Figure 9.14, and the all-propylene, hot melt bonded, general-purpose multi-layered cartridge in Figure 9.15; versions of this latter incorporate various types of media, including membranes of polypropylene, nylon and PTFE, sandwiched between protective layers of spunbonded media.

Cartridges of the type illustrated in Figure 9.15 are sold in a series of standard sizes, with manufacturers of replaceable elements competing with the original suppliers for the replacement market.

Cuno has recently introduced its Betafine XL range of pleated cartridges for liquid filtration, employing its Advanced Pleat Technology, APT produces a staggered pleat, of different depths, mixing 'W' pleats among the standard 'V' shapes, especially so that the pleats are not too pinched at their bases, thereby not losing valuable surface area for filtration. Betafine XL cartridges, made from polypropylene microfibres, are available in absolute ratings from 0.2 to 70 μm .

The more complex structure of the coalescer cartridge in Figure 9.16 results from the multiplicity of filtration stages that it combines. Contaminated fuel or oil entering the centre of the cartridge encounters first the pleated needlefelt of synthetic fibres that acts as a particulate filter and protects the outer coalescer layers. These comprise glass fibres pressed to a controlled density and thickness.

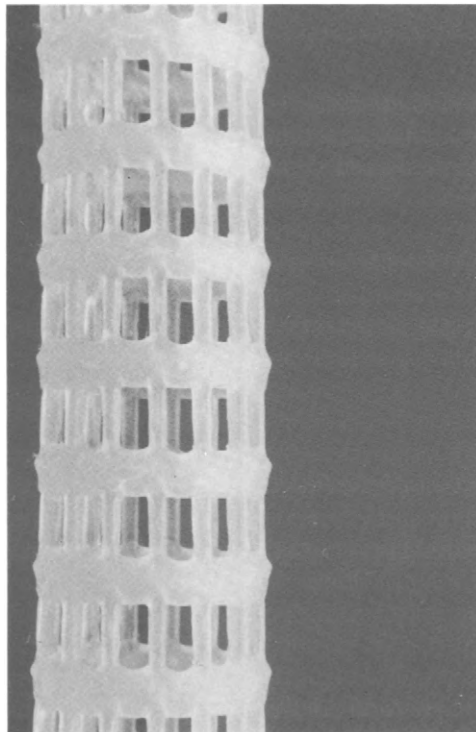

Figure 9.13. A Netlon plastic mesh core for a filter cartridge.

within which finally dispersed water coalesces into droplets large enough to separate from the fuel or oil by gravity settling.

The pleated cartridge in Figure 9.17 utilizes a single layer of sintered stainless steel fibres, sandwiched between layers of coarse mesh. These sophisticated cartridges are used for high-pressure and high-temperature applications, such as the filtration of molten polymers.

An unusual style of pleating is used by Lucas Industries in the resin-impregnated paper cartridges for their FS diesel fuel filter, which is designed to collect solid particles and also to serve as a coalescer and remove water. The cartridge comprises a thick roll of specially pleated creped paper in the form of a spiral around a central core, as shown in Figure 9.18. When inserted in the filter housing as in Figure 9.19, flow is downwards, parallel to the axis of the cartridge. Although the paper is wound closely together, the creping allows continuous flow between all the adjacent turns; evidence of this is the collected dirt visible in Figure 9.20.

A variant on the pleated paper cartridge is shown in Figure 9.21, as applied to the filtration of hydraulic oil under high pressure. This version is limited to 170 bar, while Figure 9.22 shows a more expensive version, suitable for operating pressures up to 375 bar and pressure differentials up to 17 bar. This is now an example of a reclaimable cartridge, which must be returned to the manufacturer for replacement of the used filter medium. The cartridge comprises multiple layers of graded papers interleaved with wire discs. These discs provide mechanical support and also act as fluid distributors between adjacent sets of papers, thereby ensuring simultaneous parallel flow of fluid through all the sets.

Another unusual style of pleating is featured in the novel Series 700B cartridges developed by 3M and incorporated in the High Flow Liquid Filter. As shown schematically in Figure 9.23, the meltblown polypropylene microfibre filter medium is pleated radially, as opposed to the conventional longitudinal pleating, thereby effectively forming a stack of lenticular discs. This orientation evidently allows the use of much deeper pleats, resulting in a cartridge of

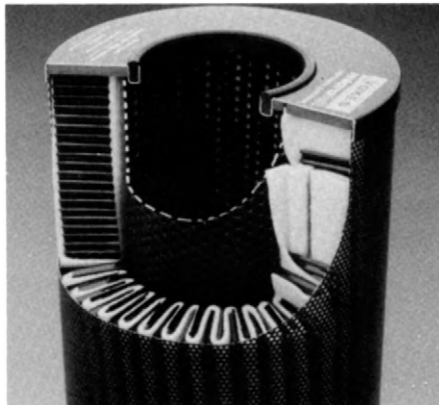

Figure 9.14. Fuel and lubricating oil filter.

relatively large diameter, as in Figure 9.24, and greatly increased filtration area, with corresponding benefits in respect of dirt-holding capacity and life. The latest version of this cartridge is the 750 KF filter, also made of meltblown polypropylene.

The pleated cellulose paper cartridge has been the mainstay of engine fluid filtration for many years. However, the demands of modern industry and commerce are such that extended service intervals are becoming normal⁽¹⁾, and filters are having to change to accept higher dirt loadings, and to achieve higher efficiencies. New types of cartridge are being developed to meet this need, while

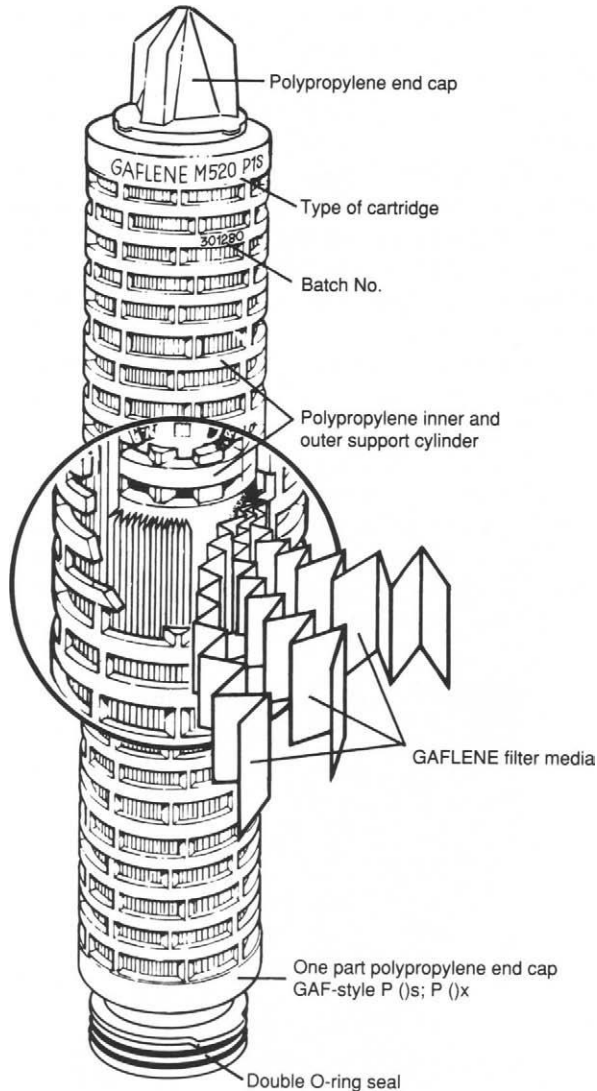

Figure 9.15. All-polypropylene multilayer general purpose filter cartridge.

small disc-stack centrifuges are also being employed. Engine oil filtration in heavy-duty engines is often effected by means of two filters in parallel – one, the full-flow filter, accepts the full liquid flow and removes particles down to 10–20 μm , while the other, the bypass filter, works on about 5–10% of the oil, and achieves very fine filtration. A new venturi combination filter replaces both full-flow and bypass filters with one unit. This has a pleated synthetic medium

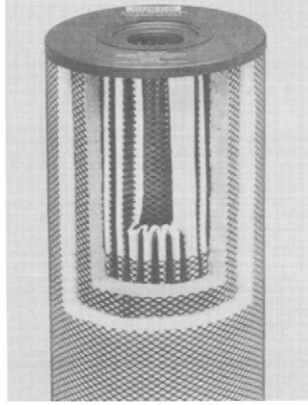

Figure 9.16. A coalescer cartridge.

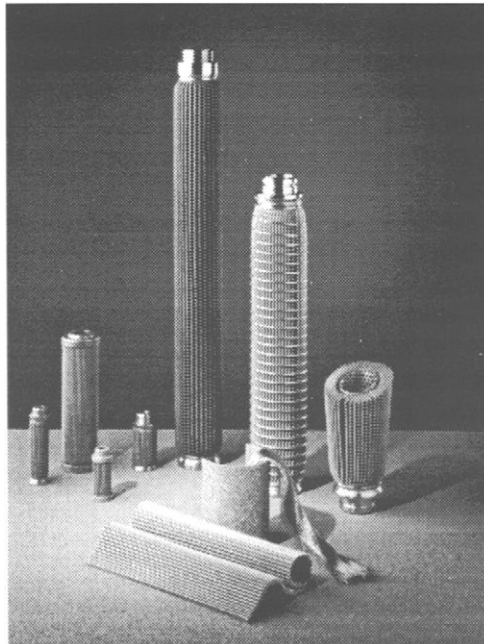

Figure 9.17. Pleated sintered metal fibre cartridges.

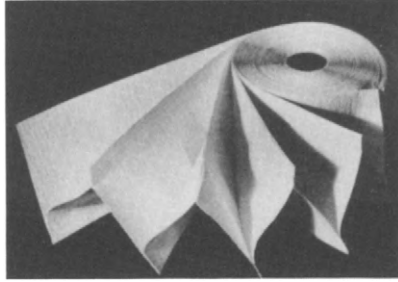

Figure 9.18. The pleated and spiral formation of paper cartridge for the FS diesel fuel filter.

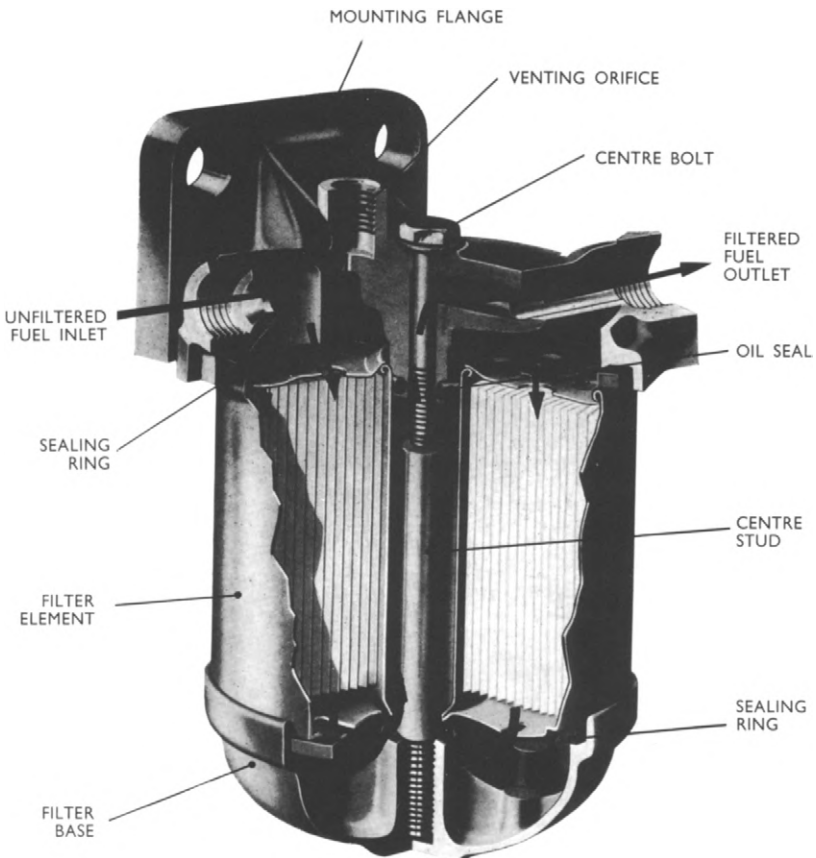

Figure 9.19. The FS diesel fuel filter.

section, connected to a stacked disc of cellulose medium by a venturi that increases the flow through the stacked discs.

Other new designs for engine oil filters are the modular incinerable cartridge (in which all parts of the disposable element are made from incinerable materials), and the in-place cleanable oil filter, which has an element that can be cleaned by back-flushing with compressed air.

9.2.4.2 *Pleated cartridges for gas filtration*

For the greater part of its life, the fabric filter used for the filtration of large volumes of inlet air or exhaust gas streams has employed filter bags for its medium. While bags are still an important part of the fabric filter scene, made largely of non-woven media, there has been a rapid influx of pleated media cartridges into gas filtration, triggered by the need for higher filtration efficiencies. The ePTFE membrane media discussed in Chapter 8 have been

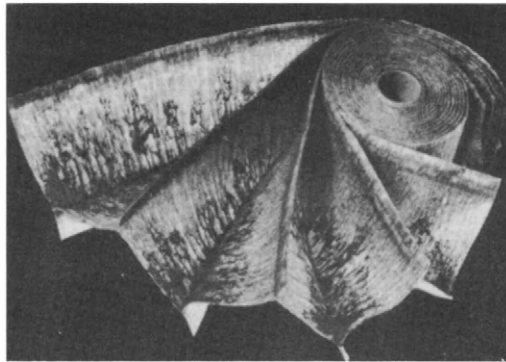

Figure 9.20. Dirt collected in all the 'vee' pleats of an FS diesel fuel filter cartridge.

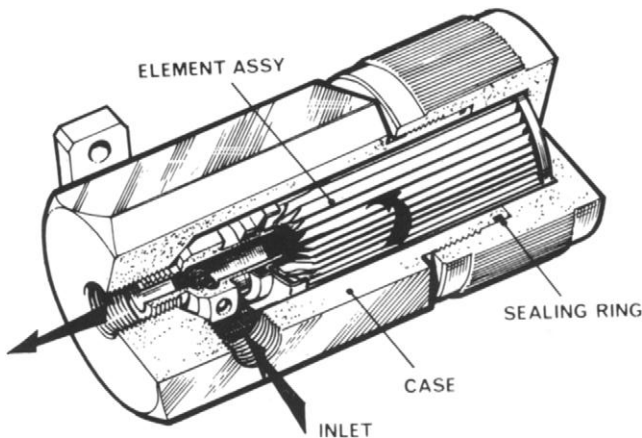

Figure 9.21. A high pressure hydraulic oil filter with a 'disposable' pleated cartridge.

especially successful in this application, because of their higher operating temperature range.

Resin-impregnated cellulose paper may be sufficiently rigid to be self-supporting without need of either a central core or spacers to maintain a gap between adjacent pleats. Illustrative of this is the engine air intake cartridge in Figure 9.25. The function of the spacers is fulfilled by the dimples that can be seen in the surface of each pleat.

Also self-supporting is the large (324 mm diameter, 673 mm high) cartridge illustrated in Figure 9.26, containing 22.3 m^2 of filter medium, comprising a chemically treated blend of cellulose and synthetic fibres. Multiple assemblies of these cartridges are applied in pulse jet cleaned dust filters, notably for the air intake to gas turbine power generation systems.

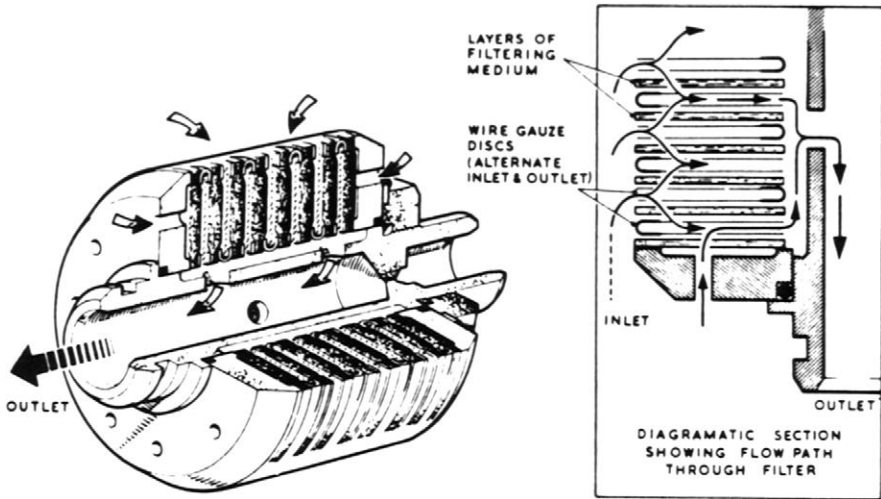

Figure 9.22. A high pressure hydraulic oil filter cartridge.



Figure 9.23. Schematic illustration of 3M Series 700B radial cartridge.

It is not only paper-like materials that can be pleated. Media made from sintered metal and even ceramic can now be pleated, as shown in Figure 9.17 and, in multi-cartridge assemblies such as Figure 9.27, for hot or corrosive gas-phase processing duties.

Most pleated cartridges used for gas filtration are circular in cross-section. However, Donaldson has recently described an oval cartridge⁽²⁾, with shorter, wider pleats, that offers higher filtration efficiency, and greater ease of cleaning. The medium is a polymer nanofibre, acting as a surface filter. The resultant filter housings are smaller than corresponding cylindrical cartridge houses would be.

9.2.5 Lenticular discs

A lenticular disc is one that has the double convex shape of a lens. This is advantageous in a filter, since it allows inward filtration to proceed through both faces, with ample space between them for the flow of filtrate into a central outlet. A stack of such discs assembled on a perforated core provides a convenient

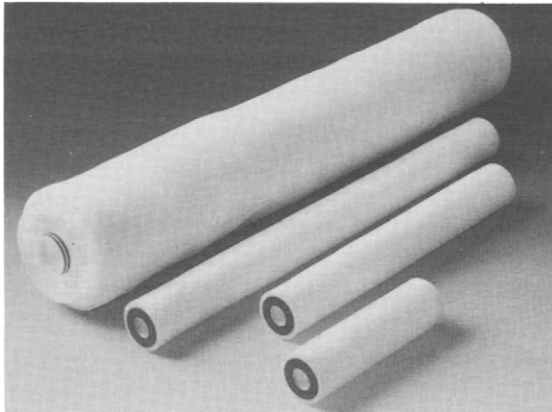

Figure 9.24. 3M filter cartridge compared with conventional 25, 50 and 75 cm cartridges.

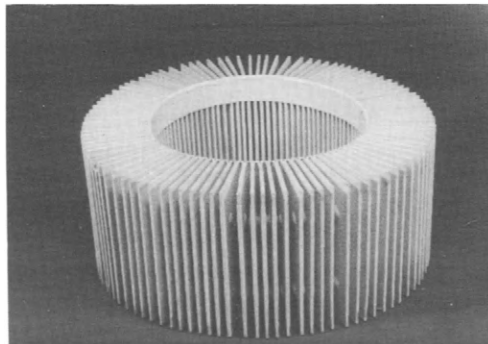

Figure 9.25. A resin impregnated cellulose paper cartridge for an engine air intake filter.

method for constructing a compact cartridge of high surface area. This format is the basis of both throwaway and cleanable long-life cartridges, depending on the type of media utilized.

The filter sheets made by Carlson from cellulose, described in Chapter 4, are available as lenticular filter cartridges. Figure 4.7 in Chapter 4 shows a similar

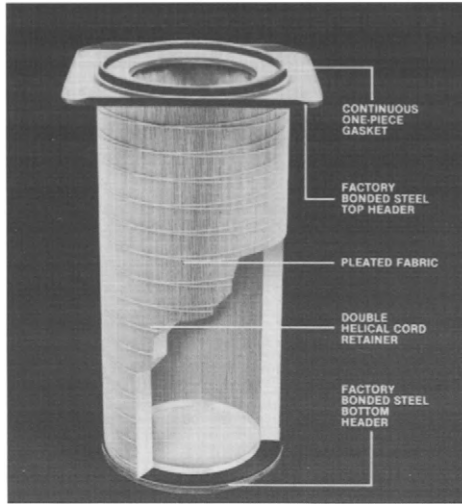

Figure 9.26. A 'Tenkay' dust filter cartridge.



Figure 9.27. A multiple assembly of pleated sintered metal fibre cartridges for high temperature gas filtration.

throwaway cartridge from Cuno's range of lenticular cartridges based on the various grades of Zeta Plus filter media, their modular construction being illustrated in Figure 9.28. A cartridge comprises an assembly of lenticular discs or cells, each of which is composed of two discs of Zeta Plus medium, sealed together around a polypropylene separator. The cartridge is pre-assembled under high compression, and is locked together by three stainless steel bands. Edge sealing of each cell is effected by an injection moulded polypropylene ring.

A similar format is shown in Figure 9.29, now with activated carbon incorporated into the Zeta Plus, in order to provide a combination filter, marketed under the ZetaCarbon brand name. Five different types of carbon can be incorporated, to decolourize liquid streams, and remove organic contaminants. These cartridges have no shedding of carbon into the filtrate, and can be supplied certificated for pharmaceutical use.

Lenticular disc stacks are another type of filter used in the filtration of molten polymers. Sintered stainless steel is the standard material required to withstand the high operating pressures (300 bar) and temperatures of the polymer industry, where, with repeated specialized cleaning, the useful life of a filter is expected to be perhaps 10 years or more. Accordingly, whilst the same lenticular format still applies, there are major differences in the detailed engineering. The most noticeable of these is that the product supplied by the manufacturer is a number of separate filter discs (which are generally known as segments), from which the customer can assemble a stack inside a suitable housing, as in Figures 9.30 and 9.31. These segments or discs are produced in two standard diameters, 175 and 200 mm.

To withstand these rigorous conditions, appropriate multi-layered construction is utilized so as to protect and support the critical layer of filter medium. As illustrated in Figures 9.32–9.35, four standard options are available from Pall, these offering different combinations of sophistication versus cost.

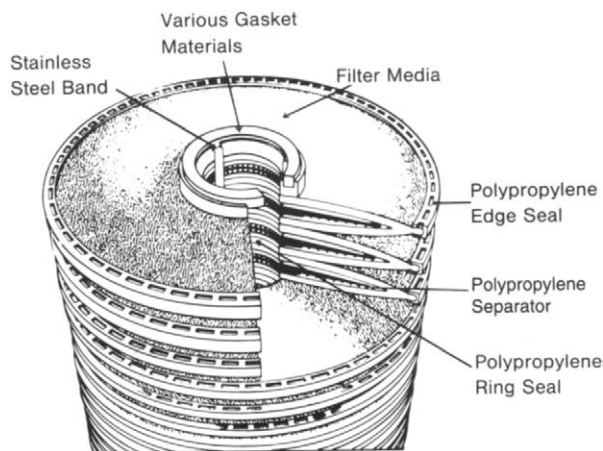

Figure 9.28. The modular construction of Cuno 'HT Series' lenticular cartridges.

9.2.6 Rigidized elements

While pleated cartridges have been the biggest recent competitor for filter bags in gas filtration, a small but important part of the market is now using rigidized elements for this purpose, because of their better operating temperature range. The version developed by Herding, described in Chapter 5, uses a pleated type of surface for a self-supporting structure of filter media, able to operate at moderately high temperatures.

Somewhat similar are the Compact Filter Elements supplied by Madison, which are available in flat, rectangular shape or as cylindrical elements. They can be made from needlefelts, spunbondeds or composites, but are mainly supplied with microporous coated or anti-static media. Their chief claim is that of much reduced cartridge size for a given filtration area.

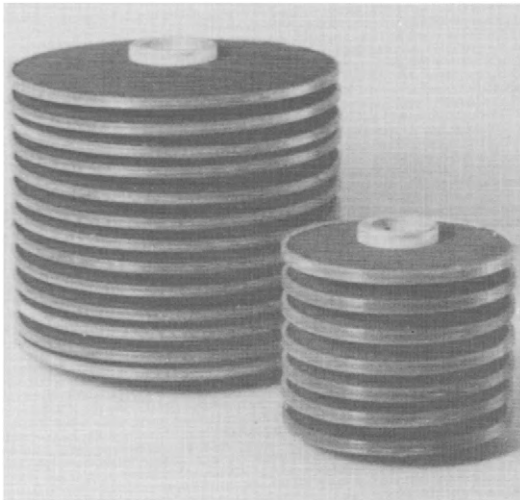

Figure 9.29. Cuno 'Zetacarbon' cartridges, incorporating activated carbon with 'Zeta Plus'.

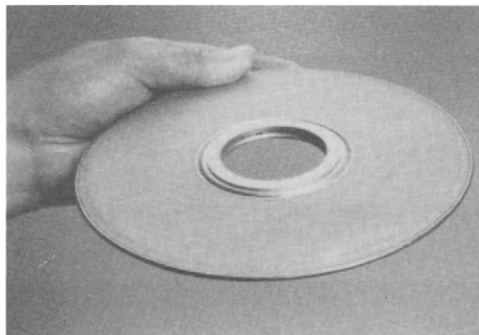

Figure 9.30. A sintered metal segment for polymer filtration.

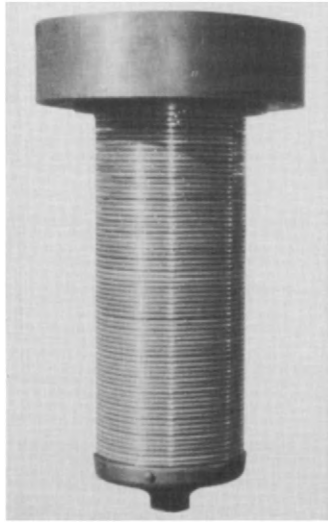

Figure 9.31. A multi-segment stack assembly for polymer filtration.

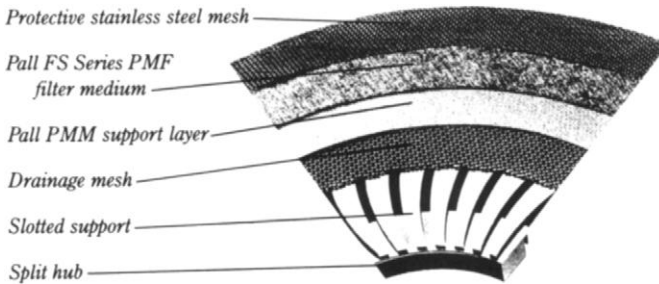

Figure 9.32. The multi-layer construction of Pall's 'Segment' filters for polymer filtration.

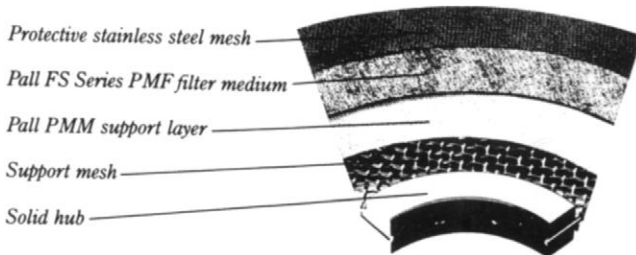

Figure 9.33. The multi-layer construction of Pall's 'Segment-M' filters for polymer filtration.

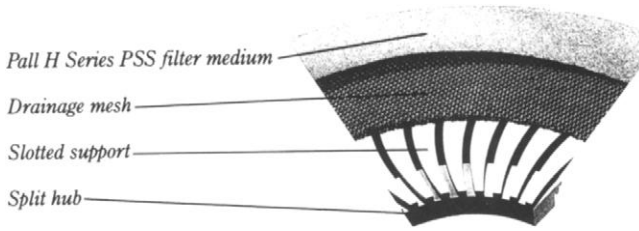

Figure 9.34. The multi-layer construction of Pall's 'Segmax' filters for polymer filtration.

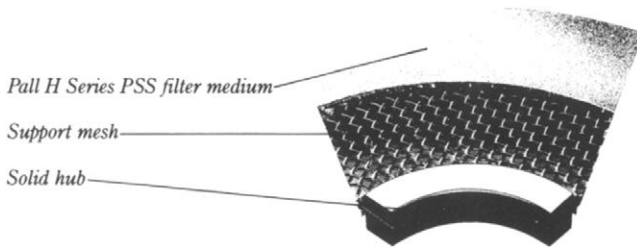

Figure 9.35. The multi-layer construction of Pall's 'Segmax-M' filters for polymer filtration.

9.2.7 Mechanically cleaned filters

A small, but growing, group of filters offers continuous operation by means of automatic mechanical cleaning of the filter element. In these filters, typified by Russell Finex's Eco and Ronningen-Petter's DCF-Series, self-cleaning filters, a rigid cylindrical cartridge of wedge wire or woven mesh construction, which can be mounted vertically or horizontally, operates with liquid flow from the inside to the outside of the cylinder. Dirt accumulates on the inside of the cylinder from which it can be scraped off – in the Eco filter by means of a continuously rotating screw-shaped blade, and in the DCF by means of a disc that periodically moves across the surface. The accumulated dirt is blown out of the filter through a valve.

9.2.8 Cross-flow membrane modules

The modules in which membrane media are supplied are strictly speaking cartridges as defined for this chapter: flat sheet, spiral wound, tubular, perforated block and hollow fibre.

These are generally expensive enough to warrant cleaning once they have reached the end of an operating cycle, so they are likely to be flushed *in situ* or removed for more thorough cleaning. Further details on such modules are given in Chapter 8.

9.3 Specially Fabricated Cartridges

The second main group of cartridges are made from components that are not in themselves filter media, but once assembled can act as very efficient media, mainly for liquid filtration. They are of three main types:

- a continuous yarn wound more or less tightly onto a central core;
- a medium made from fibres assembled into a relatively thick medium on a central core; and
- an assembly of discrete solid components or continuous wires or ribbons, which are mounted on or wound round a central core.

The first two are depth media, the third is a surface medium, that is easily made into an automatically cleaned filter. The cores for the first two types are similar to those shown in Figures 9.12 and 9.13.

9.3.1 Yarn-based cartridges

The most common of the yarn-based cartridges is that in which a continuous yarn of natural or synthetic fibre is wound around a central core. However, there is growing interest in an alternative yarn based design, where a bundle of yarns is held in different orientations at different parts of the filtration cycle.

9.3.1.1 Yarn wound

Despite its early origin in the 1930s, the 63 mm diameter \times 250 mm long yarn-wound (or spool-wound) cartridge illustrated in Figure 9.36 continues to be widely used in many sectors of industry. Its simple construction, and its convenient versatility in use, resulted in its becoming an unofficial standard as increasing numbers of manufacturers competed for a large and growing market. It also effectively served as a prototype in respect of size and dimensions for the diversity of styles of cartridge developed in more recent years, during which there has also been diversification of both diameter and especially length. Both shorter and longer lengths are common, up to a general maximum of 1.02 m because of the flow restriction of the core.

These cartridges are constructed by continuously winding yarn in a carefully controlled open pattern around a central core, which is typically a perforated metal or plastic tube open at each end. Typically the matrix so formed has a graded structure with pores of decreasing size with the inward direction of flow – a gradation achieved by differing degrees of tightness in the windings. Cartridges are based on a wide variety of yarn materials embracing both natural and synthetic fibres. The yarns used are mostly spun from short staple fibres, the fibrillated surface of which is brushed or teased to produce a fuzzy surface or nap, which contributes importantly to the filtration mechanisms. If monofilament yarns are used they are generally texturized or crimped in some fashion before being formed into a cartridge.

The filtration characteristics of a cartridge depend on the type of yarn used as well as on the way it is produced and wound. Examples of the pressure drop versus flow rate of water through 250 mm cartridges of various yarn materials are provided in Figure 9.37.

Cartridges are typically graded in terms of a nominal micrometre rating, generally with seven or eight models to straddle the range from about 1 to 150 μm . It is customary to identify the grading and constructional parameters of a yarn-wound cartridge by a coding system such as the example shown in Table 9.1.

Considerable care is needed in applying the grading numbers, partly because some suppliers are more optimistic in their claims than others, and also because the performance achieved may vary substantially with the operating conditions. In general, it is unlikely that a cartridge will achieve better than say 80% efficiency against particles of the size specified by the nominal rating; in practice, considerably lower efficiencies may well be achieved.

The possible impact of changes in flow rate on both efficiency and cartridge life is demonstrated by the data in Table 9.2, which is adapted from an early paper by

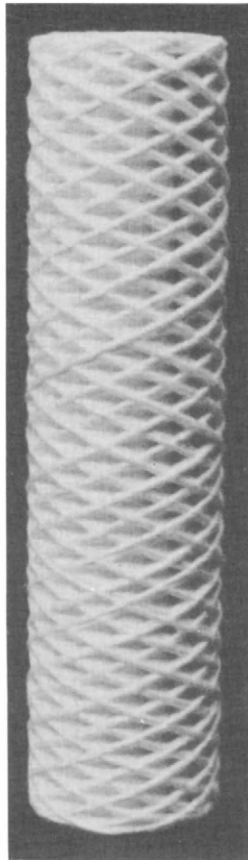

Figure 9.36. A typical yarn-wound or spool-wound cartridge.

Swanson⁽³⁾. A study reported by Williams and Edyvean⁽⁴⁾, comparing cartridges of nominally identical ratings from three different manufacturers, noted a great deal of variation not just among filters from different manufacturers, but also among a manufacturer's own cartridges. In general, retention efficiency was observed to be low initially, rising during the mid-period and finally falling again; a three-fold extension in filter life was found between cotton and polypropylene cartridges from the same supplier.

The dirt-holding capacity is also dependent on various operating factors including velocity, as can be seen from the data in Table 9.2. Whilst the actual performance depends on numerous factors, as a rough guide it may be assumed

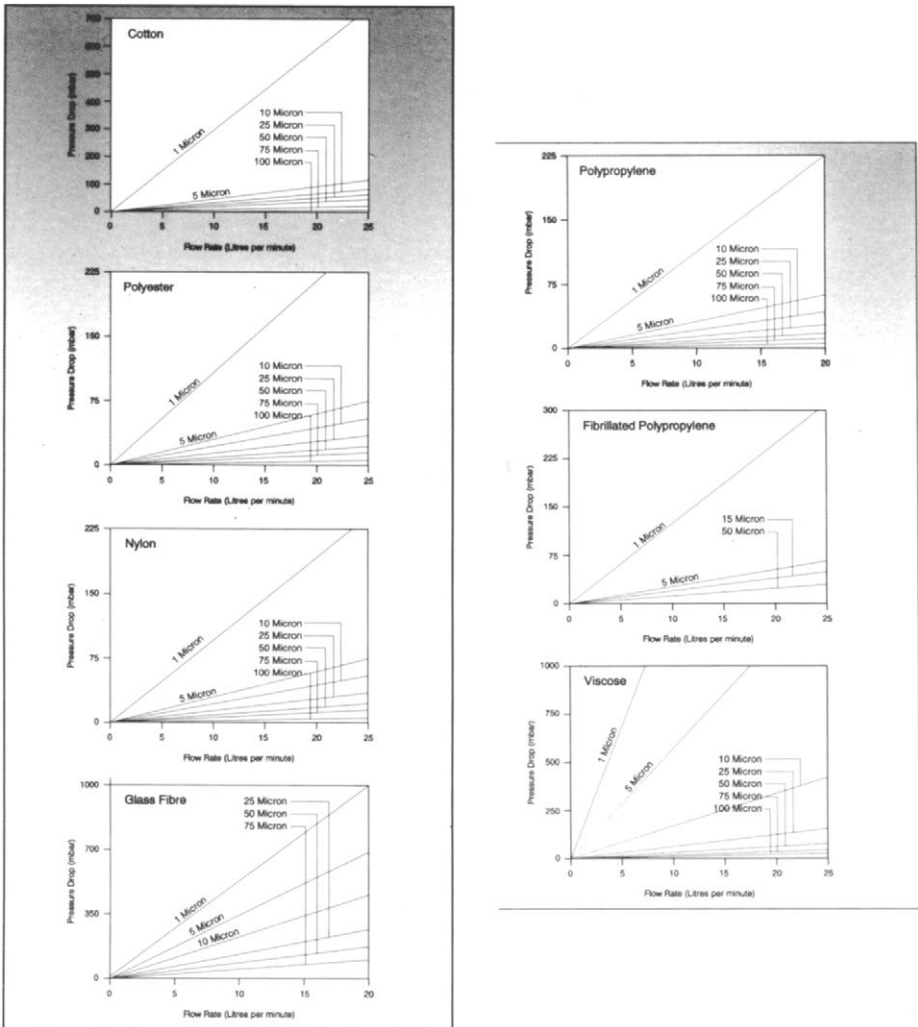

Figure 9.37. Pressure drop versus the flow rate of water through Ametek 50 mm wound cartridges.

that the weight of dirt that can be held in a standard 25 cm cartridge is approximately 50 g for a 1 µm grade, 90 g for 15–20 µm, and 120 g for 50–100 µm.

Figures 9.38 and 9.39 are reproduced from Williams and Edyvean⁽⁴⁾ since they produce an interesting comparison between polypropylene and cotton cartridges, and demonstrate the magnitude of some of the variations that can

Table 9.1 Coding system used to specify a filter cartridge^a

Length			Micron rating		Yarn	Core type		Diameter		End fitting		
Inch	mm	Code	Code	Code	Code	Code	mm	Code	Code	Code		
4	100	04	0.5	A5	Polyester	01	Polyester	1	62	1	Standard end (DOE)	0
5	125	05	1	01	Polypropylene	02	Polypropylene	2	50	2	Millipore (6)	2
6	160	06	3	03	Fibrillated polypropylene	03	304 St steel	3	100	6	Millipore (0)	3
9.75	248	09	5	05	Bleached cotton	04	316 St steel	5	66	7	Gelman (D)	6
9.875	251	10	10	10	Glass fibre	06	Tinned steel	7			Pall (7)	7
10	254	11	20	20	Nylon	07					Pall (8)	8
19.75	500	19	25	25	Rayon viscose	08					Ametek	9
20	508	20	50	50	Washed polypropylene	09						
29.5	750	29	75	75								
30	762	30	100	99								
39.25	1000	39										
40	1016	40										
Example: 29			20		02		2		1		0	

^aPTI Technologies Ltd.

Table 9.2 The effect of flow rate on the performance of filter cartridges

Cartridge grade (µm)	Flow rate (l/min)	Initial pressure drop (bar)	Filtration efficiency (%)	Total volume filtered up to 2.4 bar final pressure drop (m ³)
1	1.9	0.11	96.2	1.08
1	9.5	0.63	95.2	0.68
1	19.0	1.22	95.6	0.52
10	1.9	0.01	85.4	6.25
10	9.5	0.05	79.4	3.00
10	19.0	0.19	71.6	1.85

occur; the superior performance of cotton was attributed to the stratified surface of its fibres and to their swelling by absorption of water, thereby reducing the porosity.

The Cuno MicroWynd II, shown in Figure 9.40, is a novel form of wound cartridge, which comprises alternate layers, one a blanket of carded fibres and the other wound yarn, both being either cotton or polypropylene. The primary function of the yarn layers is to lock in place the fibre blanket that acts as the main filter medium. The advantages claimed for this patented construction include a three-fold increase in flow capacity and a doubling of the dirt-holding capacity.

Another interesting development⁽⁵⁾ claims to overcome many of the problems experienced with yarns made from roving or friction spun yarns of cotton or polypropylene fibre, namely, shedding of fibre and leaching of fibre treatment

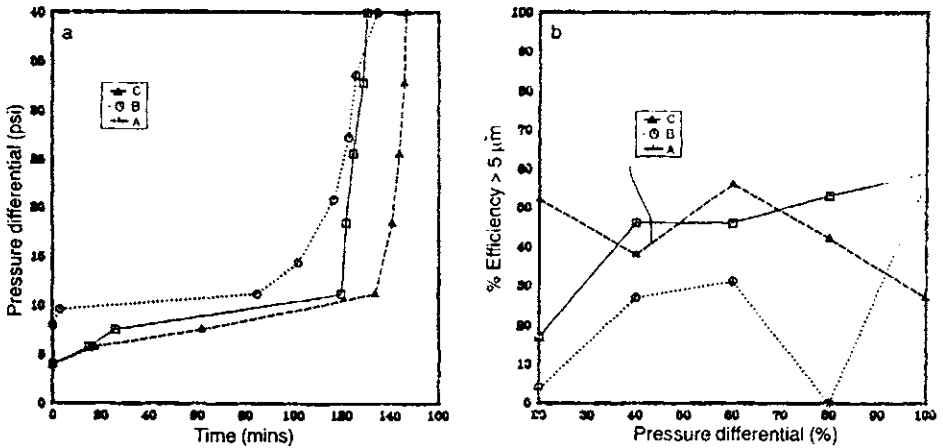

Figure 9.38. The performance of 5 µm polypropylene filter cartridges.

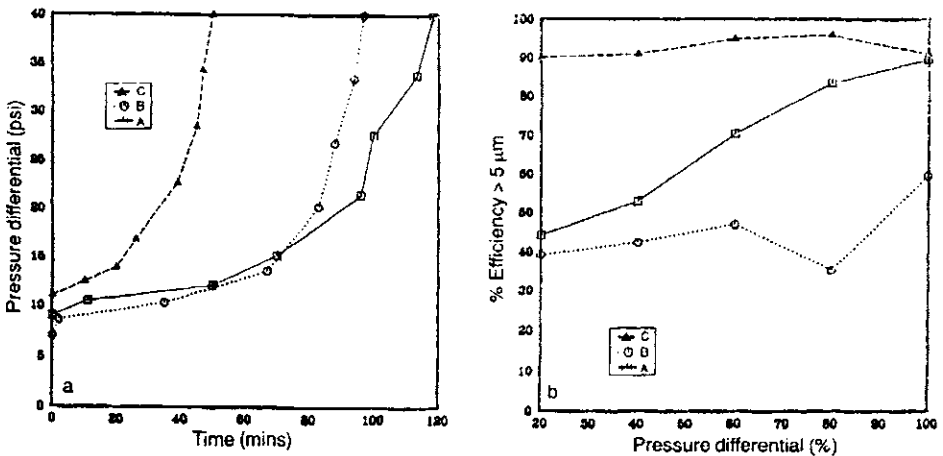

Figure 9.39. The performance of 5 µm cotton filter cartridges.

chemicals. Syntech Fibres uses continuous meltspun filaments of polypropylene to make the yarn. Each of the filaments continues throughout the whole length of the yarn. The filaments are randomly oriented to each other (intermixed, looped and entwined) to form a very bulky, non-round, highly stable yarn. A cartridge wound from this material has a high-efficiency depth filtration mode of operation.

9.3.1.2 Kalsep's Fibrotex cartridge

A unique cartridge of yarns forms the heart of Kalsep's novel Fibrotex filter, which was originally developed by British Petroleum with the water filtration problems on off-shore platforms as the intended target. The cartridge or filter element, shown in Figure 9.41, is formed of a bundle of yarns loosely arranged around a central perforated tube, which is mounted between two circular end plates, with the ends of the yarns also attached to these plates.

The operating cycle of the filter is shown schematically in Figure 9.42. To prepare for inward filtration, the top end plate is moved downwards and simultaneously rotated through about half a turn, so that the yarns are twisted and compressed into a helical pattern that brings them tightly together against the central tube. During backwash cleaning, the element is expanded by upward movement of the top plate and by a reciprocating partial rotation of that plate.

The yarns, which are crimped, are of Nylon-66 or PBT polyester; with both they are six denier (i.e. 30 μm). In their twisted mode they form a bed some 50–



Figure 9.40. The 'Micro-Wynd II' cartridge combines a blanket of carded fibres with wound yarn.

60 mm thick. The filtration efficiency achieved is 98% against 2 μm particles with Nylon-66 and 95% against 5 μm particles with PBT; Figure 9.43 is a grade efficiency curve for Nylon yarns based on challenge tests with AC Fine test dust.

9.3.2 Bonded fibres

The next group of specially fabricated cartridges covers those in which a layer of fibre is laid down on a core and then held in place by some means – chemical or

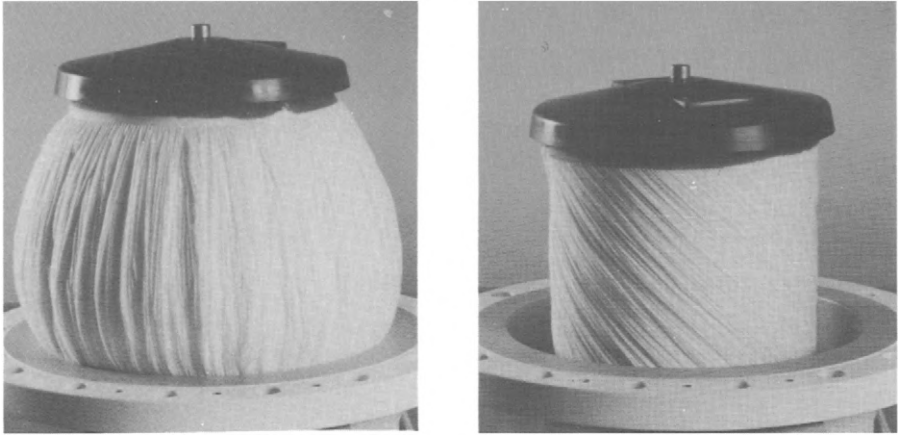

Figure 9.41. The 'Fibrotex' filter element (a) relaxed, (b) twisted.

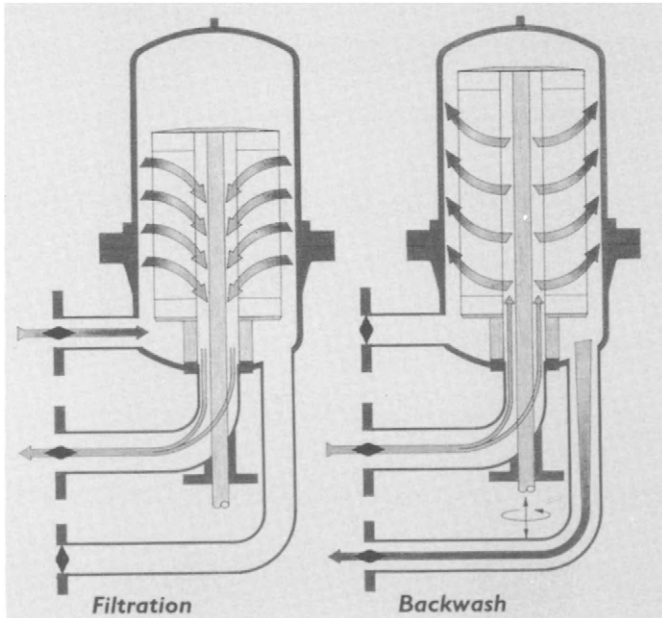

Figure 9.42. The 'Fibrotex' filter element is compressed or expanded during the operating cycle.

thermal. These can give as good a separation efficiency as the yarn-wound cartridges, with a wider range of fibres.

9.3.2.1 Resin bonded

Figure 9.44 shows the structure of a cartridge formed from glass microfibres that are bonded together by either a phenolic resin (for general applications) or melamine (to meet the special requirements of food, beverage and pharmaceutical duties). The microfibres, produced in controlled sizes ranging from less than $0.5 \mu\text{m}$ to more than $150 \mu\text{m}$, are manufactured by the 'pot and marble' process outlined in Chapter 4.

Fibres from this process are sprayed with a resin and then formed into felt-like mats. These are cut into predetermined lengths and rolled on to various sized mandrels, which correspond to the inside diameter of the filter tube. The length of the matter and the rate at which it is rolled onto the mandrel determine the

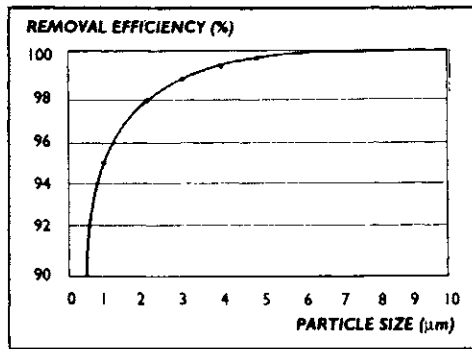

Figure 9.43. Particle removal efficiency of the 'Fibrotex' Nylon 66 filter element.

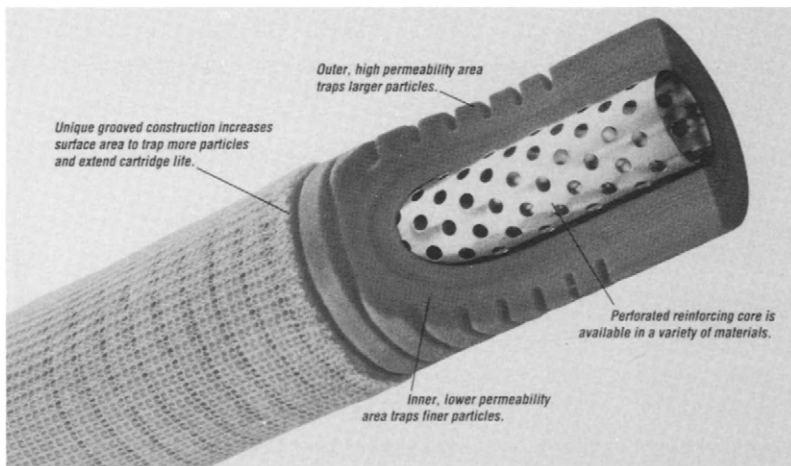

Figure 9.44. A resin-bonded glass microfibre cartridge.

density of the resultant tube, which is of graded density, increasing towards the core. Following curing, each tube is ground to the required diameter and grooved to increase the available surface area.

Various options are available for the core, including polypropylene, metal (tin-coated steel or stainless steel) and resin impregnated. The eight grades produced by Johns Manville are identified simply in numerical sequence from 1 for the finest to 8 for the coarsest, to straddle the range of nominal micron ratings of competing suppliers.

Bonded cartridges of similar form, but made from other fibres, are typified by the coreless Fulflo RBC (i.e. Resin Bonded Cartridge) from Parker Hannifin Corporation. Extra-long acrylic fibres with phenolic bonding are used to make these coreless cartridges. In addition to the grooved form, non-grooved cartridges are available for use where increased depth filtration is required. Both styles are available in seven grades with nominal ratings of 2, 5, 10, 25, 50, 75 and 125 μm .

Acrylic and cellulose fibres are the basis of Cuno's graded-density coreless Beta-Klean cartridges, which are available in both grooved and non-grooved forms. A distinctive feature of this range, linked to its name, is that the cartridges are characterized not by nominal micrometre ratings, but by *absolute ratings* that specify the particle size at a Beta ratio of 1000, corresponding to a filtration efficiency of 99.9%. On this basis, the range of 10 grades extends from the finest at 5 μm up to 70 μm .

9.3.2.2 *Thermoplastic bonded*

Exploiting the thermoplastic properties of synthetic polymers such as polypropylene has proved a fertile ground for the development of novel constructions and manufacturing processes for filter cartridges. Advantages available from these materials and manufacturing techniques include the ability to produce fibres in a wide range of controlled diameters and lengths, and also to form beds of graded pore size, as in the example in Figure 9.45, the finest grade of which has a typical efficiency of 99.999% against 0.3 μm bacteria. In addition, thermal bonding (i.e. without using adhesives) is simple, convenient and compatible with sensitive applications (e.g. food and pharmaceuticals).

Several of these cartridge designs are briefly described below, based partly on a classification by Shucosky⁽⁶⁾. They each utilize a different technique to achieve a graded porosity down to a controlled minimum pore size, high permeability to provide a low flow resistance, high dirt-holding capacity, and maximum mechanical stability to withstand deformation under pressure.

The key feature of *thermal moulded polyolefin (TMP) cartridges* is the bicomponent nature of the fibres from which they are formed. These fibres have a sheath of lower melting point polymer surrounding a higher melting point core. Hence, when a web of these fibres is rolled and carefully heated, the sheath material will soften and fuse at the myriad of fibre contact points. This creates a rigid cartridge structure that does not require the support of a central core; end caps and gaskets are thermally welded to the cartridge without use of a resin.

An example of this type of cartridge is the Cuno range of Betapure cartridges. Both polyolefins and polyester versions are available; the former are constructed from long fibres with an inner core of polypropylene and an outer sheath of polyethylene, while the others utilize a core of polyester surrounded by copolymer polyester. The fused bonding of the sheaths, illustrated in Figure 9.46, provides a rigid structure without fibre shrinkage or degradation.

The range of nine polyolefin cartridges are graded only by nominal micrometre ratings, from 1 to 100 μm ; during manufacture, the fibres are processed on textile equipment that requires a fibre lubricant. Five grades of polyester cartridge have both nominal and absolute (99.9% efficiency) ratings, as listed in Table 9.3; flow rate of water versus pressure drop characteristics for standard 25 cm long cartridges are summarized in Figure 9.47.

Meltblown depth (MBD) cartridges are manufactured by an adaptation of the meltblown fibre technology outlined in Chapter 3. Molten polymer extruding from spinneret orifices is impacted by high-velocity streams of air, which cause the filaments to fibrillate and disintegrate into fine short fibres. These short fibres are then deposited directly onto a rotating mandrel. The process attempts to produce a desired mean pore size by varying the fibre diameters across the depth of the filter medium; as the filter is being formed, the mean fibre diameter is changed by adjusting the air velocity or other significant variable, such as temperature and polymer pumping rate.

Examples of MBD cartridges are the Osmonics Purtrex, Hytrex II and Selex polypropylene filters. While the first two are graded on a nominal basis only (respectively with efficiencies of 75–80% and 85–90%), the Selex cartridges are rated in Table 9.4 at several efficiency levels up to 99.98% ($\beta = 5000$). Flow rate of water versus pressure drop characteristics for standard 25 cm long cartridges are summarized in Figures 9.48–9.50.

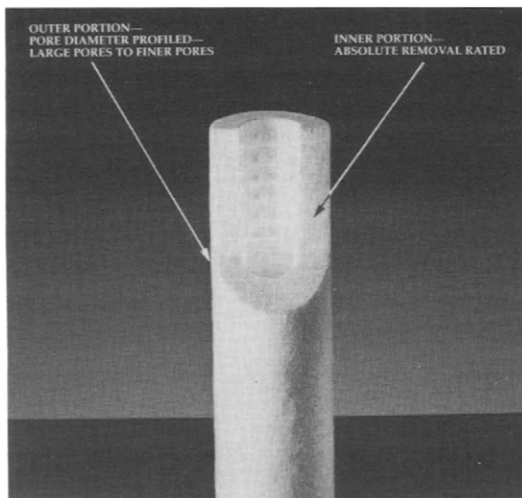

Figure 9.45. A thermally-bonded polypropylene 'Profile' filter cartridge.

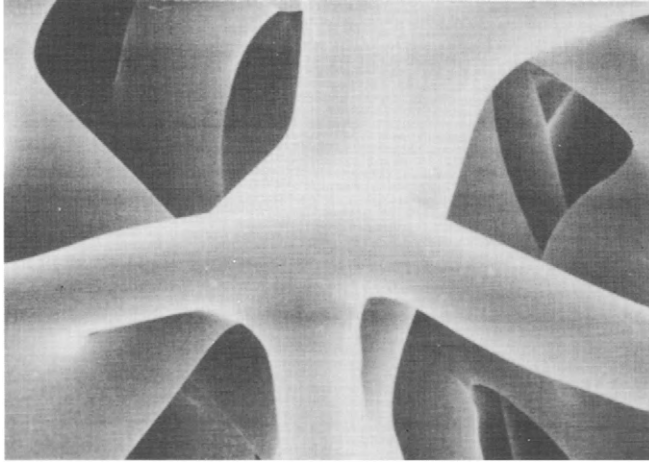

Figure 9.46. Thermal bonding of bicomponent polyester fibres in 'Betapure' cartridges.

Table 9.3 The nominal and absolute ratings of 'Betapure' polyester cartridges^a

Grade	Nominal rating (μm)	Absolute rating ^b (μm)
A	3	6
B	5	15
C	10	23
E	20	35
G	30	N/A

^a Cuno Europe.

^b 99.5% efficiency.

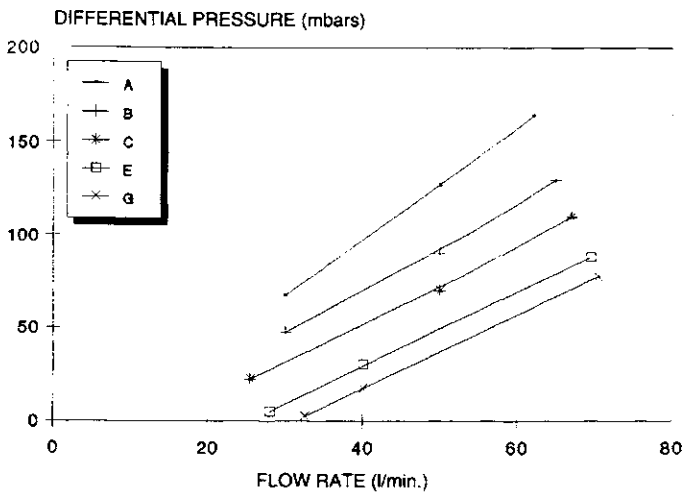

Figure 9.47. Differential pressure versus flow rate of water through 'Betapure' polyester cartridges.

A refinement of this manufacturing technique, with computerized control of fibres extruded simultaneously from multiple spinnerets, results in the closely graded layers of Filterite's Nexis cartridges. These utilize a novel fibre technology identified as co-located large diameter (CoLD) melt fibre technology⁽⁷⁾, wherein high-efficiency fibres of 1 µm or less are intermingled with much larger ones (up to 100 µm), which provide mechanical strength to the resultant matrix. A range of 17 grades with nominal ratings (90% efficiency) from 0.5 to 200 µm is

Table 9.4 Nominal and absolute ratings of 'Selex' polypropylene cartridges^a

Grade of 'Selex' cartridge	E	G	D	A	C	F	
Nominal micron rating (µm)	1	3	5	10	20	30	
Micron rating @ efficiency.	β ratio						
90	10	0.5	0.7	0.9	1.0	1.3	1.8
95	20	1.1	1.5	1.8	2.0	2.4	3.0
98	50	1.5	1.8	2.9	4.3	5.0	6.5
99	100	3.2	5.2	7.3	8.4	9.7	11.0
99.5	200	15.1	17.5	18.9	19.3	20.0	—
99.98	500	16.6	18.9	20.8	24.2	32.1	—

^a Osmonics, Inc.

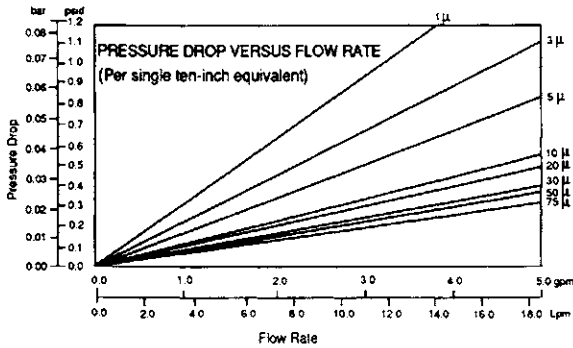

Figure 9.48. Water flow/pressure characteristics of 'Purtrex' 25 cm cartridges.

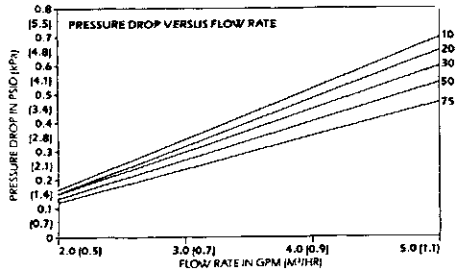
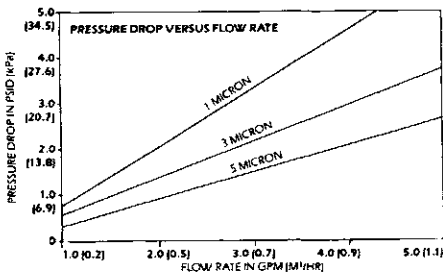

Figure 9.49. Water flow/pressure characteristics of 'Hytrex II' 25 cm cartridges.

supplied, of which the water flow versus pressure drop characteristics are summarized in Figure 9.51: an absolute rated range (99.9% efficiency) from 5 to 20 μm is also available.

The third of these special techniques produces *rolled multi-layer depth (RMD) cartridges*. As illustrated in Figure 9.52, these all-polypropylene cartridges are formed by wrapping multiple layers of graded meltblown media around a rigid core. A continuous length of open mesh runs through the whole construction to support the filter medium layer and to keep the consecutive layers separate from each other. Each layer is fabricated separately and carefully controlled and monitored in respect of parameters such as permeability, porosity, pore size and thickness. Multiple layers of a particular grade are used as appropriate, while the overall form comprises an absolute rated inner section of fine fibres and multiple outer prefilter sections.

The nominal and absolute (99.9% efficiency) particle removal ratings of the eight grades of cartridge produced by Filterite (now part of Pall) are listed in Table 9.5, which also includes ratings at lower β factors and efficiencies. Flow rate of water versus pressure drop characteristics for standard 25 cm long cartridges are summarized in Figure 9.53.

A somewhat similar structure is the basis of Cuno's new PolyNet depth cartridges. These comprise three layers of polypropylene filter media, each with varying flow distribution channels, interleaved with layers of distribution netting. The decreasing size and number of flow channels from one layer to the next creates evenly distributed, longitudinal and latitudinal flow paths across each successive layer, enabling the full capacity of the filter element to be utilized, whilst maintaining consistent levels of filtration. An inner layer of medium without flow channels ensures the absolute rated performance, in the range 1–70 μm .

9.3.3 Metal edge filters

Filters of this category are so named since the apertures through which filtration takes place are created by the close proximity of a series of parallel metal plates, strips or wires, the assembled edges of which thereby form the filter medium.

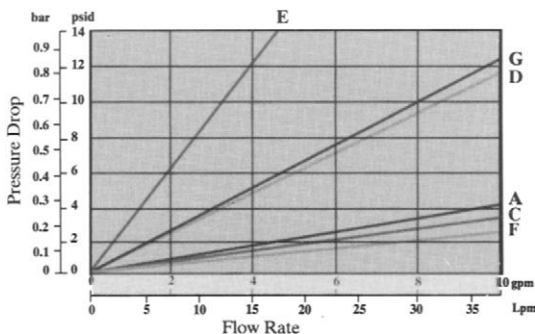
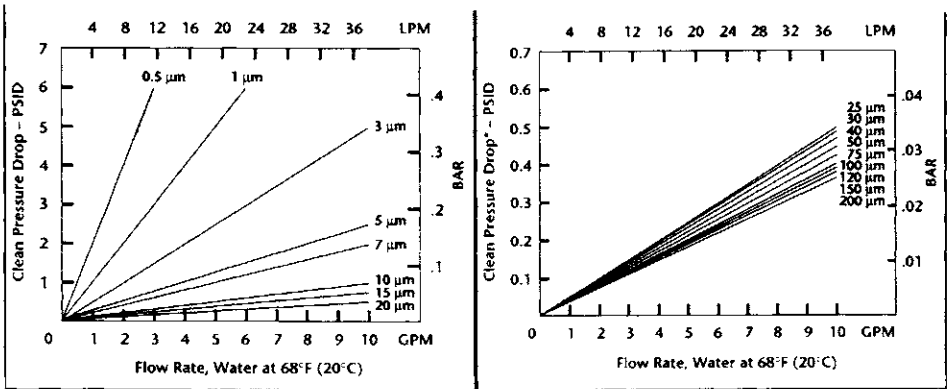

Figure 9.50. Water flow/pressure characteristics of 'Selex' 25 cm cartridges.

9.3.3.1 Wire-wound structures

A typical example of this form of construction is illustrated in Figure 9.54. A screw thread is cut into the surface of the support or former, into which a continuous wire is then wound, with the gap between adjacent turns controlled down to a minimum of about 50 μm ; this allows far closer control of the gap size than is possible with welded construction, such as the Trislot tubes described in Chapter 6, for which the tolerance is 10% of the nominal slot.



* Due to the very low flow resistance of the media in the more open grades, pressure drop is primarily related to turbulent loss through the center core.

Figure 9.51. Water flow/pressure characteristics of 'Nexis' 25 cm cartridges. GPM=US gpm; LPM=l/min.

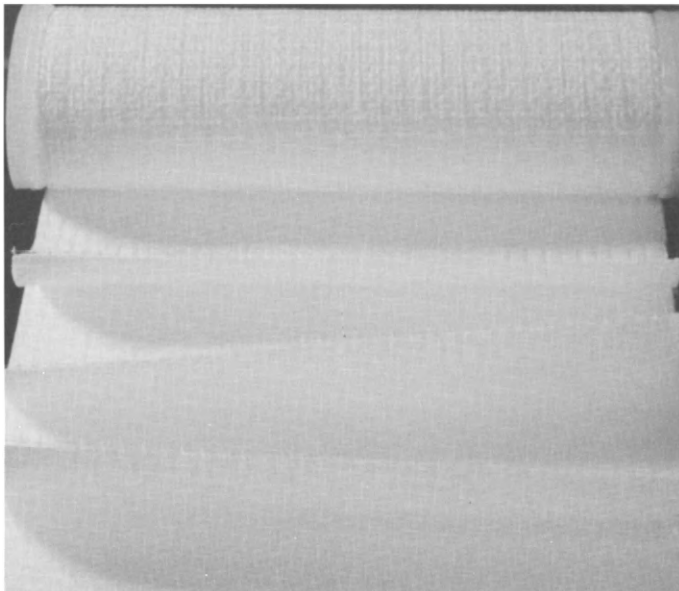

Figure 9.52. The multi-layer structure of 'Poly-fine ARD' 25 cm cartridges.

The wire may be either of circular section or wedge-shaped with a triangular section, the flat surface facing outwards so that the gaps between the wires widen in the direction of flow, which is radially inwards. The advantage of wedge wire is that the filter element is less prone to blocking, as can be seen from the schematic diagram in Figure 9.55.

Although about 50 μm is the normal minimum gap between wires, much finer clearances are achieved by the Japanese company Arai Machinery Corporation and its US associates Pure-Grade Inc. By machining to close tolerances both the

Table 9.5 Particle removal ratings of 'Poly-fine ARD' cartridges^a

Beta β :	1000	100	50	10
Efficiency (%):	99.9	99	98	90
Nominal micron rating				
0.5	< 0.5	< 0.5	< 0.5	< 0.5
1.0	0.9	0.8	0.7	< 0.5
3.0	2.5	2.0	1.7	1.3
5.0	3.6	2.8	2.6	2.0
10.0	7.5	5.9	5.2	4.0
20.0	15.0	12.0	11.3	8.3
40.0	33.0	28.0	23.0	18.0
70.0	65.0	60.0	50.0	40.0

^a Filterite.

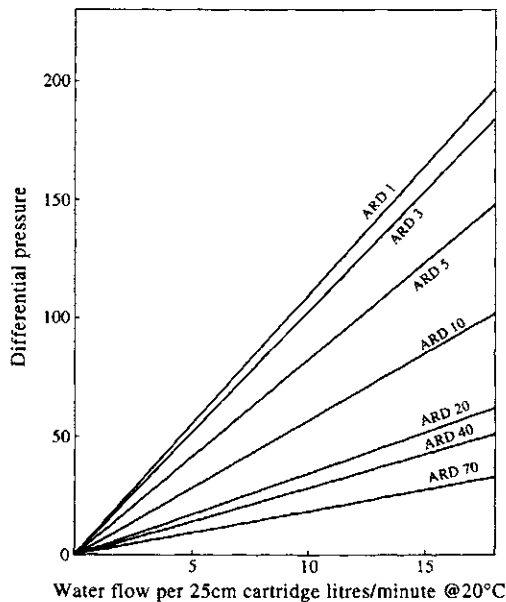

Figure 9.53. Flow/pressure characteristics of 'Poly-Fine ARD' cartridges.

support cylinder and the wedge wire, the standard range of gaps available starts at 1, 3, 5 and 10 μm and extends through another 15 grades up to 300 μm ; the gap tolerances are as precise as 0.5 μm for 1 and 3 μm gaps, and 2 μm above this size. In 316 stainless steel or titanium, both externally wound and internally wound elements are produced, as can be seen in Figure 9.56; the smallest is 44 mm diameter by 60 mm long, the largest is 266 mm diameter by 250 mm long.

9.3.3.2 Ribbon elements

The filter element shown in Figure 9.57, which was formerly one of the range of Purolator filters, comprised a tightly wound spiral coil of a wedge-shaped metal ribbon, both ends being locked firmly onto a central supporting frame. The height of the projections at regular intervals on the upper broad face of the ribbon determined the width of the apertures between adjacent turns of the spiral, typical widths being from 50 to 500 μm . Cleaning of the filter was by means of a spring steel scraper, rotated around the element.

A superficially similar spiral coil with regular projections forms the heart of the Salisbury and other water filters produced by the Cross Manufacturing Company. But there are significant differences in the Cross coil that explain the success of these automated filters. A small but significant difference is that the cross-section of the metal is not wedge-shaped but rectangular.

The major distinctive feature of the 125 cm long Cross element is that it is a spring coil that, under gravity, opens evenly, whereas a conventional coil forms uneven gaps as illustrated in Figure 9.58. This characteristic results from the patented technology used to manufacture Cross coils from superior aircraft grade stainless steel. Its great advantage is that cleaning by backwashing an opened coil is equally effective over the entire length of the element, since the backwash is evenly distributed. Six grades of element are available with micrometre ratings of 12–400 μm .

9.3.3.3 Stacks of rings

Probably the best-known example of the filter element using a stack of rings is that in the Metafilter. It was invented in the 1920s by Pickard (who is also remembered as the author of a classic text on filtration⁽⁸⁾), and found wide use in the precoat clarification of liquids in the chemical, processing and food industries; evidence that some of these are still in operation is the orders for spare parts which continue to be received by Stella-Meta, TM Products Ltd.

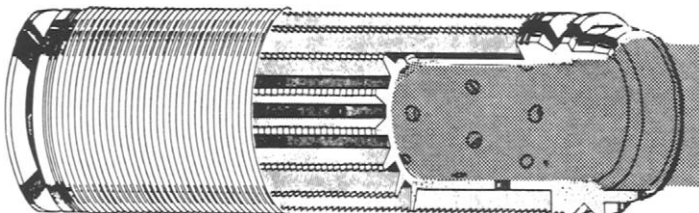

Figure 9.54. A wire wound element based on a former with a screw thread.

The Metafilter element comprises a stack of scalloped rings assembled on a central grooved rod, as illustrated in Figure 9.59. One face of each ring is flat, whilst on the other is a series of scalloped areas (shown shaded) protruding above the surface. They are of a standard size, 19 mm outside diameter, 16 mm inside diameter and 8 mm thick, and may be of various metals (stainless steel, carbon steel, bronze, monel, etc.) or of plastic. The height of the scallops controls the aperture between the adjacent rings of an assembled stack; this may vary but is typically 100 μm .

In the Rellumit Fipoca back-flushing filter, which is mostly used for hydrocarbon fuel oils, the plastic (e.g. Nylon) rings are grooved on both faces, as in Figure 9.60. The cross-sectional shape of each groove is that of an equilateral triangle, its dimensions increasing progressively with the inward direction of flow. The rings have an outside diameter of 35 mm, an internal diameter of 25 mm and a thickness of between 1 and 2 mm, depending on the grade, which ranges from a nominal 5 to 600 μm .

The plate type strainer, as shown in Figure 9.61, used typically for duties such as lubricating oil filtration, is another form of disc stack element. It comprises an alternating assembly of rings of two different diameters, which are separated by spacing washers of a thickness selected to give the required apertures down to about 25 μm . A complementary series of fixed cleaner blades projects into the gaps so that rotation of the element dislodges accumulated dirt and scrapes it clean. Versions of this basic design are the range of Turno Klean filters listed in Table 9.6.

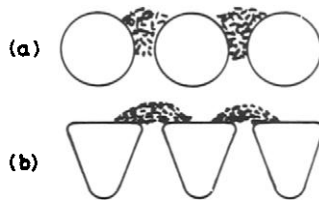

Figure 9.55. Wedge shaped wires (b) are less prone to blocking than circular wires (a).

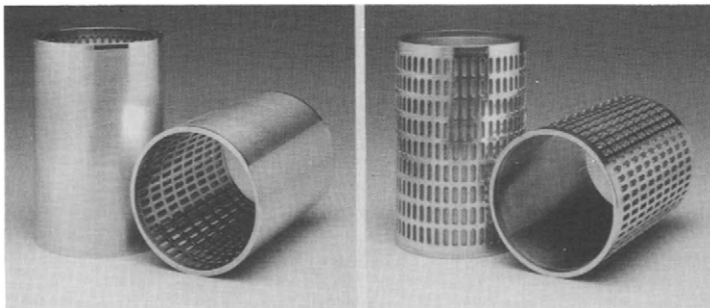

Figure 9.56. Externally and internally wound cells.

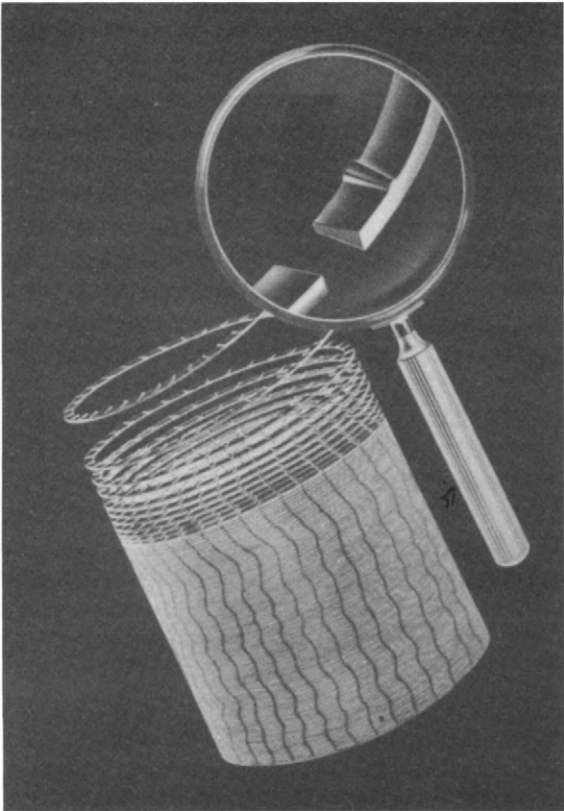

Figure 9.57. The ribbon wound construction of a former Purolator filter.

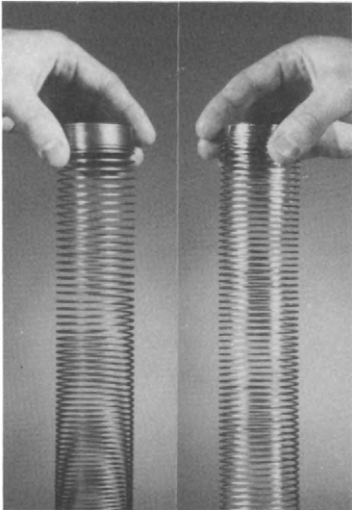

Figure 9.58. Compare the uniform opening of a Cross coil (on the right) with a conventional coil (on the left).

The Streamline filter provides a distinctive use of a stack of rings of material to form an element or cartridge, because the discs are of paper. As shown in Figure 9.62, they are clamped firmly together by a spring-loaded head, and may be of various types of paper and impregnated paper, or of materials such as polypropylene, depending on the liquid to be filtered. Filtration takes place by the liquid flowing through the very narrow interstices between adjacent discs, leaving solid contaminants down to about 1 μm in size on the outer cylindrical surface of the element. Cleaning by reverse blowing with compressed air allows repeated use of the cartridge. Invented in the early 1920s, this unique filter continues to be used primarily for the clarification of insulating oils and of lubricating oils for compressors and hydraulic systems.

9.4 Other Replaceable Elements

There are several small types of filtration device that include filter media as integral parts of the whole unit. These are usually for use in laboratory

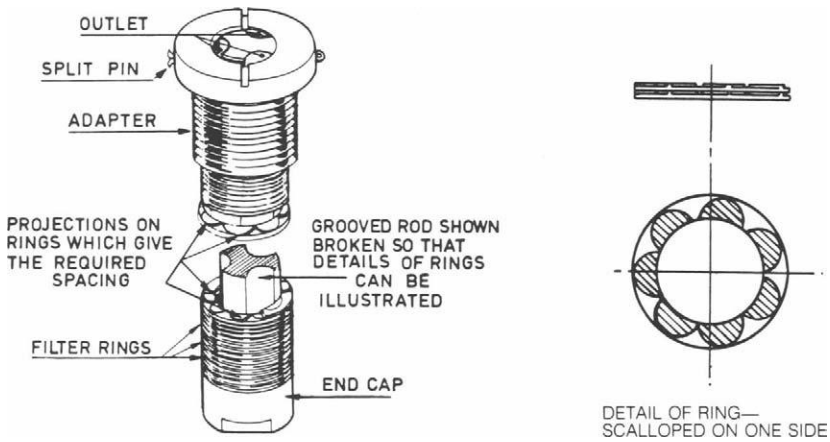

Figure 9.59. Stack of scalloped rings forming an element of a Metafilter.

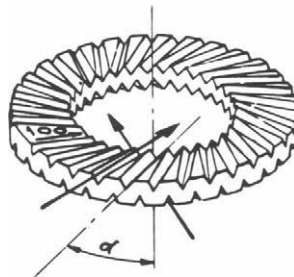

Figure 9.60. Grooved rings form the element of the 'Fipoca' filter.

situations, and are frequently called 'capsules'. They are mostly in the form of a polymeric housing, with a disc of filter medium sealed across it, intended mainly for 'guard duty' ahead of some delicate piece of apparatus.

The medium is most likely to be of membrane type, so as to retain viable particles as well as other fine solids.

There is a growing trend to employ this type of filter in industrial situations, especially in the biochemical sector, for the production of biopharmaceuticals and cytotoxic drugs. One of the problems of such operations is to achieve

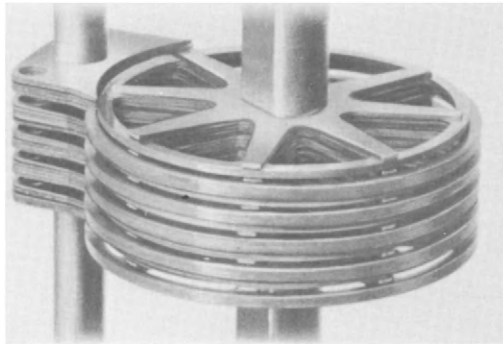

Figure 9.61. The plate type strainer or filter.

Table 9.6 'Turno Klean' and 'Super Turno Klean' plate type filters^c

Filter element length (inch)	Spacing (μ)	Open area (cm^2)	Viscosity CST			
			20	65	150	430
			Flow rate (l/mm) ^a			
5	35 ^b	17	132	79	42	17
	90	34	57	34	22	10
	125	51	72	49	30	15
	200	64	98	79	42	21
8	35 ^b	29	197	129	61	26
	75 ^b	57	200	155	76	33
	125 ^b	93	200	167	83	36
	90	74	91	57	34	15
	125	83	113	79	49	24
	200	116	159	114	70	34
	380	169	189	133	87	42
500	192	200	155	100	55	

^a Flow rate clean at 0.21 bar pressure drop.

^b Super Turno Klean.

^c Cuno Europe S.A.

adequate degrees of cleanliness in all parts of the plant, including the housings for disposable filters. Pall⁽⁹⁾ has two solutions to this:

- a steam-sterilizable capsule filter, with a housing of polyetherimide, and various media materials; and
- a pre-sterilized bag/filter combination, in which a laminated plastic bag, complete with filter, connecting tubing and couplers is provided pre-sterilized by gamma irradiation.

9.5 Selecting Cartridges

There are two distinct filtration zones covered by the cartridge formats described in this chapter:

- coarse or macrofiltration – strainers, metal edge filters, and many bag filters;
- fine or microfiltration – ventilation filters, many bag filters, most cartridges with conventional media, yarn-based and bonded fibre cartridges, and capsules;
- with some forms of the latter increasingly penetrating the submicrometre filtration applications (especially the pleated cartridges using membrane media).

The first decision is therefore of the level of particle size requiring to be removed, and then a medium is sought to match the conditions of the separation: gas or liquid, hot or cold, corrosive or mild, and so on.

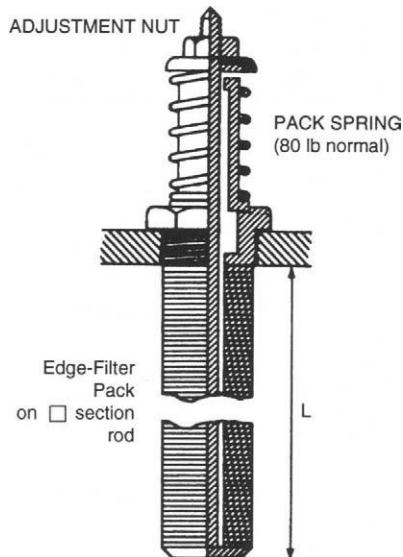

Figure 9.62. The 'Streamline' edge filter element comprises a compressed stack of paper discs.

Most makers of replaceable elements have a large range of types of cartridge on offer, usually with good guidance as to the right choice to be made.

Thus, the specialist cartridge supplier, Amazon, has a range of cartridges described in the detail of Table 9.7. These are in addition to a set of bag filters for liquid use, and a parallel set of housings for bags and cartridges. Each category is allocated to a fairly precise set of applications, mainly in the process industries. The cartridges can be seen to cover a particle size range from the top of ultrafiltration (0.03–0.05 μm) to beyond the top of microfiltration.

The Parker Filtration Division of Parker Hannifin has extended its range of supply from its traditional markets of utility fluid filtration into the process field, and now supplies a very large range of cartridges, as indicated in Table 9.8. In addition to these process filtration cartridges, Parker offers a range of pleated media elements for hydraulic, lubrication and coolant oils, mainly of glass microfibre; a range of compressed air filter elements (mainly from the Balston range); a range of depth and pleated filters and coalescers for engine fluids; a range of high efficiency filter bags for liquid filtration; and absorbent cartridges for hydrocarbon removal from gases.

Table 9.7 Amazon's range of cartridges^d

Range	Rating	Medium	Type	Grade ^a	Length ^a
SupaGard	Nominal	PP	Bonded	4: 1–100 μm	6: 125–1016 mm
SupaSpun II	Absolute	PP	Bonded	10: 0.5–180 μm^{b}	6: 125–1016 mm
SupaSpun NN	Absolute	Nylon	Bonded	9: 1–90 μm	5: 125–1016 mm
SupaPore PP	Absolute	PP	Pleated	7: 0.6–40 μm	4: 247–1016 mm
SupaPore FP	Absolute	Glass	Pleated	3: 0.3–1 μm	4: 247–1016 mm
SupaPore VP	Absolute	PES	Pleated	6: 0.03–0.8 μm	4: 247–1016 mm
SupaPore TP	Absolute	PTFE on PP ^c	Pleated	5: 0.05–1 μm	4: 247–1016 mm
SupaPleat	Absolute	Glass or PP	Pleated	8: 1–75 μm	6: 125–1016 mm

^a Number of size grades or cartridge lengths and range.

^b $\beta = 5000$ for 0.5–20 μm .

^c PTFE membrane on polypropylene substrate.

^d Amazon Filters Ltd.

Table 9.8 Parker's range of process filtration cartridges*

Yarn wound	Polypropylene, cotton, Nylon, glass microfibre, rayon, polyester (0.5–150 μm)
Resin bonded	Probond acrylic (1.0–120 μm)
Thermally bonded	1.0–120 μm : Megabond absolute rated spunbonded PP; Durabond bicomponent; Ecobond graded density PP
Pleated	0.2–70 μm : Abso-Mate absolute rated PP; Glass-Mate absolute rated glass microfibre; Poly-Mate nominal rated PP; PCC nominal rated cellulose; Flo-Pac nominal rated, large diameter cellulose; Slurry-Mate PP for solid particle classification
Membrane	PES, Nylon, PTFE (0.03–1.0 μm)

* Parker Filtration Division, Parker Hannifin.

The ranges illustrated in Tables 9.7 and 9.8 show the very wide range of cartridges available. Both of these suppliers, as do most other manufacturers, offer extensive guidance to potential users of their products, and, by extension, to the whole range of replaceable element filters covered by this chapter.

9.6 References

1. B M Verdegan *et al.* (2001) 'Engine oil filtration – technical responses to changing customer needs', *J. Filtration Society*, **1**(4), 17–19
2. P Meinke and T Raether (2002) 'Evolution of cartridge dust collection technology', *Filtration & Separation*, **39**(3), 24–6
3. R Swanson (1967) 'A laboratory study of variables affecting the life and efficiency of cartridge filters', *Proceedings of AIChE 61st National Meeting*, Houston, TX
4. C J Williams and R G J Edyvean (1995) 'Testing cartridge filters in aqueous media: interpreting the results – the pitfalls and problems. Part I. Evaluating performance methods; Part II. The problems and pitfalls of cartridge filter performance evaluation', *Filtration & Separation*, **32**(2), 157–61; **32**(3), 255–9
5. H Omar (2002) 'Continuous filament media revolutionize string wound cartridges', *Filtration & Separation*, **39**(2), 28–31
6. A Shucosky (1993) 'Absolute efficiency depth filter cartridge advances', *Filtration & Separation*, **30**(1), 21–6
7. M Crittenden (1998) 'CoLD melt technology redefines depth cartridge filtration', *Filtration & Separation*, **35**(3), 231–3
8. J A Pickard (1929) *Filtration and Filters – An Outline of the Art*, Ernest Benn Ltd, London
9. K Wickert (2000) 'Disposable filters', *The Chemical Engineer*, IChemE, 9 Nov., pp. 18–19