

**INTRODUCTION**

Air conditioning is a familiar phenomenon in households and public spaces around the world. Its application for comfort means the provision of warm (achieved by heating or cooling), filtered air. High moisture content or humidity is oppressive, but a low humidity may cause irritation by excessive loss of moisture from the skin. In some climates, steps may be taken to add or remove water vapor from the air. The air is cleaned, usually by passage through a fabric filter, which may be dry or moistened with a viscous liquid, and heated electrically or by banks of finned tubes supplied with steam or hot water over which the air is blown. Electrostatic precipitation provides an alternative method of air cleaning. The fine particles entrained in the air are charged by the absorption of electrons as they pass between two electrodes. The charged particle then migrates in the electrical field and is finally arrested on one electrode.

The same general principles apply to the supply of air in some pharmaceutical processes. However, the control of its quality may be more stringent. In areas in which sterile materials are made and handled, for example, the air cleaning must remove bacteria. In other processes, it may be necessary to remove water vapor. The flow of powders is a sensitive function of moisture content. The equilibrium moisture content of a material is determined by the humidity. Some tableting processes break down if the humidity is too high. In such processes, the scale of the air conditioning varies. It may be necessary to supply a whole room with air of a certain quality. Alternatively, conditioning may be restricted to a small area surrounding a particular piece of equipment.

**VAPOR AND GAS MIXTURES**

The humidity of a vapor-gas mixture is defined as the mass of vapor associated with unit mass of the gas. This principle is generally applicable to any vapor present in any noncondensable gas. In this section, however, only water vapor in air is considered. The percent humidity is the ratio of ambient humidity to the humidity of the saturated gas at the same temperature, expressed as a percentage. These terms should be carefully distinguished from the relative humidity with which they are distantly related. The relative humidity is the ratio of the partial pressure of the vapor in the gas to the partial pressure when the gas is saturated. This is also usually expressed as a percentage. The relative humidity of a given vapor-gas mixture changes with temperature, but the humidity does not.

The study of the properties of the air–water vapor mixture is called psychrometry, and data is presented in the form of psychrometric charts. These take various forms and present various data (Perry and Chilton, 1999). In Figure 6.1, humidity is plotted as the ordinate and temperature as the abscissa. Percent relative humidity is then plotted as a series of curves running across the chart. The use of this simplified chart is demonstrated later in this chapter and in the succeeding chapter.

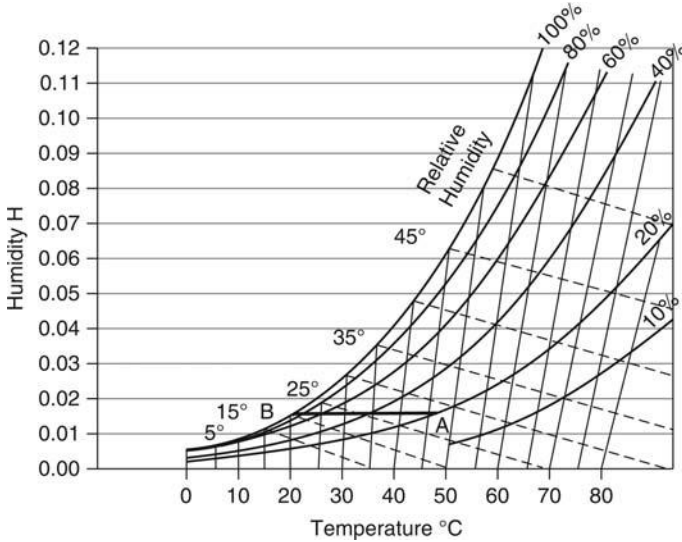

**FIGURE 6.1** A psychrometric chart that can be used to determine the humidity.

### HYGROMETRY, THE MEASUREMENT OF HUMIDITY

The accurate determination of the humidity of air is carried out gravimetrically. The water vapor present in a known volume of air is chemically absorbed with a suitable reagent and weighed. In other less laborious methods, the humidity is derived from the dew point or the wet bulb depression of a water vapor–air mixture.

The dew point is the temperature at which a vapor-gas mixture becomes saturated when cooled at constant pressure. If air of the condition denoted by point A in Figure 6.1 is cooled, the relative humidity increases until the mixture is fully saturated. This condition is given by point B at which the temperature coordinate is the dew point. This can be measured rapidly by evaporating ether in a silvered bulb. The temperature at which dew deposits from the surrounding air is noted, and the humidity is read directly from a psychrometric chart.

The derivation of the humidity from the wet bulb depression requires a preliminary study of the transfer of mass and heat at a boundary between air and water. Since this process is also of importance in the study of drying, a detailed explanation is set out below. If a small quantity of water evaporates into a large volume of air, conditions that make the change in humidity negligible, the latent heat of evaporation is supplied from the sensible heat of the water. The latter cools, and the temperature gradient between water and air promotes the flow of heat from the surrounding air to the surface. As the temperature falls, the rate of heat flow increases until it equals the rate at which heat is required for evaporation. The temperature at the surface then remains constant at what is known as the wet bulb temperature. The difference between the air temperature and the wet bulb temperature is the wet bulb depression. If these temperatures are denoted by  $T_a$  and  $T_{wb}$ , the rate of heat transfer,  $Q$ , is given by equation (6.1).

$$Q = hA(T_a - T_{wb}) \quad (6.1)$$

where  $A$  is the area over which heat is transferred and  $h$  is the heat transfer coefficient. Mass transfer of water vapor from the water surface to the air is described by equation (6.2).

$$N = \frac{k_g}{RT} (P_{wi} - P_{wa}) \quad (6.2)$$

where  $P_{wi}$  is the partial pressure of water vapor at the surface and  $P_{wa}$  is the partial pressure of water vapor in the air.  $k_g$  is a mass transfer coefficient, and  $N$  is the number of moles transferred from unit area in unit time. Rewriting this equation in terms of the mass,  $W$ , transferred at the whole surface in unit time, where  $M_w$  is the molecular weight of water vapor and  $A$  is the area of the surface:

$$W = \frac{M_w A}{RT} k_g (P_{wi} - P_{wa}) \quad (6.3)$$

If the partial pressure of water vapor in a system has the value  $P_w$ , then, from the general gas equation, the mass of vapor in unit volume is  $P_w M_w / RT$ . Similarly, if the total pressure is  $P$ , the mass of air in unit volume is  $(P - P_w) M_a / RT$ , where  $M_a$  is the "molecular weight" of the air. The humidity,  $H$ , is the ratio of these two quantities:

$$H = \frac{P_w}{P - P_w} \frac{M_w}{M_a} \quad (6.4)$$

If  $P$  is very much greater than  $P_w$ ,  $H = P_w M_w / P M_a$ . Rearrangement and the substitution of humidity for partial pressure in equation (6.3) give

$$W = \frac{P M_a}{RT} k_g A (H_i - H_a) \quad (6.5)$$

where  $H_a$  is the humidity of the air and  $H_i$  is the humidity at the surface. The latter is known from the vapor pressure of water at the wet bulb temperature. Since  $P M_a / RT = \rho$ , equation (6.5) can be written as

$$W = \rho k_g A (H_i - H_a) \quad (6.6)$$

where  $\rho$  is the density of the air. If the latent heat of evaporation is  $\lambda$ , the heat transfer rate necessary to promote this evaporation is given by

$$Q = \rho k_g A (H_i - H_a) \quad (6.7)$$

Equating the expressions (6.7) and (6.4) then gives

$$H_i - H_a = \frac{h}{\rho k_g \lambda} (T_a - T_{wb}) \quad (6.8)$$

Both the heat and mass transfer coefficients are functions of air velocity. However, at air speeds greater than about 4.5 m/sec, the ratio  $h/k_g$  is approximately constant. The wet bulb depression is directly proportional to the difference between the humidity at the surface and the humidity in the bulk of the air.

In the wet and dry bulb hygrometer, the wet bulb depression is measured by two thermometers, one of which is fitted with a fabric sleeve wetted with

water. These are mounted side by side and shielded from radiation, an effect neglected in the derivation above. Air is then drawn over the thermometers by means of a small fan. The derivation of the humidity from the wet bulb depression and a psychrometric chart will be discussed later.

Many wet and dry bulb hygrometers operate without any form of induced air velocity at the wet bulb. This may be explained by examining another air-water system. If a limited quantity of air and water is allowed to equilibrate in conditions in which heat is neither gained nor lost by the system, the air becomes saturated and the latent heat required for evaporation is drawn from both fluids, which will cool to the same temperature. This temperature is the adiabatic saturation temperature,  $T_s$ . It is a peculiarity of the air-water system that the adiabatic saturation temperature and the wet bulb temperature are the same. If water at this temperature is recycled in a system through which air is passing, the incoming air will be cooled until it reaches the adiabatic saturation temperature at which point it will be saturated. The temperature of the water, on the other hand, will remain constant, and all the latent heat required for evaporation will be drawn from the sensible heat of the air. Equilibrium is then expressed by the following equation:

$$(T_a - T_\infty)S = (H_\infty - H_a)\lambda \quad (6.9)$$

where  $T_a$  is the temperature of the incoming air and  $S$  is its specific heat.  $H_a$  and  $H_\infty$  are the humidities of the incoming air and the saturated air, and  $\lambda$  is the latent heat of evaporation for water.

The process of adiabatic saturation in which the humidity progressively rises and the temperature progressively falls is described on a humidity chart by adiabatic cooling lines, which run diagonally to the saturation curve. Charts are specially constructed so that these lines become parallel.

If a wet and dry bulb hygrometer is exposed to still air, the region adjacent to the wet bulb closely resembles the system described above. After a considerable period, equilibrium will be attained and the wet bulb will record the adiabatic saturation temperature.

When both wet and dry bulb temperatures have been found, the humidity is read from the psychrometric chart in the following way. The point on the saturation curve corresponding to the wet bulb temperature is first found. An adiabatic cooling line is then interpolated and followed until the coordinate corresponding to the dry bulb temperature is reached. The humidity is read from the other axis.

The change in the physical properties of a hair or fiber with change in humidity is utilized in many instruments. After calibration, they are suitable for use over a limited range of humidity.

## HUMIDIFICATION AND DEHUMIDIFICATION

Most commonly, air is humidified by passage through a spray of water. Three methods are illustrated by the humidity diagrams drawn in Figure 6.2. In the first, air at a temperature  $T_1$  is heated to  $T_2$  (Fig. 6.2(A)). The latter temperature is chosen so that adiabatic cooling and saturation followed by heating to  $T_4$  will give a humidity rise from  $H_1$  to  $H_2$ . The humidification stage is performed by passing the air through water sprays at the adiabatic saturation temperature,  $T_3$ . Alternatively, the incoming air could be heated to  $T_5$ , air of the correct humidity

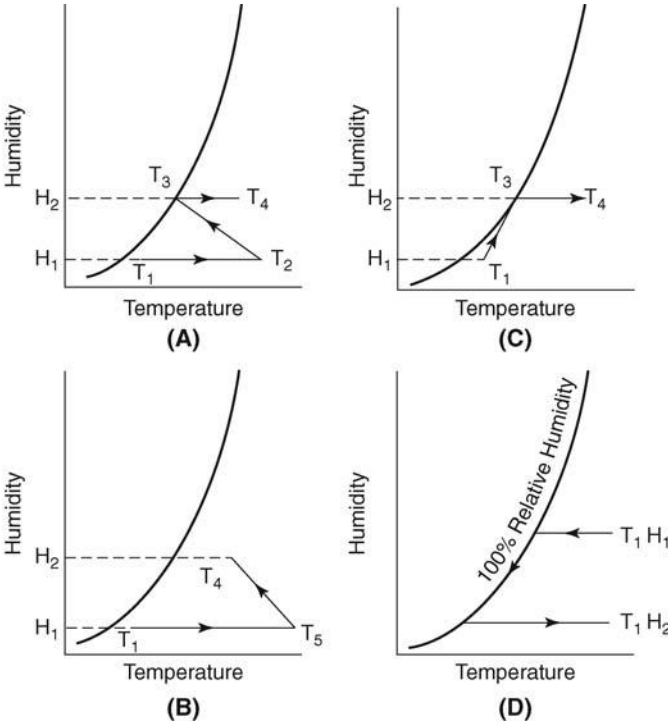

**FIGURE 6.2** The humidification and dehumidification of air.

emerging when it is adiabatically cooled to  $T_4$  with water (Figure 6.2(B)). In neither of these methods is control of the water temperature necessary. In the third method, air of humidity,  $H_1$ , and temperature,  $T_1$ , is passed through and saturated by a water spray maintained at  $T_3$  (Figure 6.2(C)). On leaving the chamber, it is heated to  $T_4$ .

For small quantities of air, dehumidification is most easily accomplished by adsorbing water vapor with alumina or silica gel arranged in columns. These are mounted in pairs so that one can be regenerated while the other is in use. Alternatively, the air can be cooled below the dew point. Excess water vapor condenses and the cold, saturated air is then reheated. For well-mixed gases, the process is described in Figure 6.2D.

## INTRODUCTION

Drying is a ubiquitous process in the handling and preparation of pharmaceuticals, and it may be defined as the vaporization and removal of water or other liquid from a solution, suspension, or other solid-liquid mixture to form a dry solid. The change of phase from liquid to vapor distinguishes drying from mechanical methods of separating solids from liquids such as filtration. The latter often precede drying since, where applicable, they offer a cost-effective method for removing a large part of the liquid.

Drying, as defined above, may still be confused with evaporation. Greater precision is not possible because the division of the two operations is to some extent arbitrary. Drying is normally associated with the removal of relatively small quantities of liquid to give a dry product. Evaporation is more often applied to the concentration of solutions. However, exceptions to these generalizations occur.

Adjustment and control of moisture levels by drying is important in the manufacture and development of pharmaceutical products. Apart from the obvious requirement of dry solids for many operations, drying may be carried out to

1. improve handling characteristics, as in bulk powder filling and other operations involving powder flow and
2. stabilize moisture sensitive materials, such as aspirin and ascorbic acid.

A wide range of drying equipments are available to meet these ends, but in practice, the choice is limited by the scale of the operation and may be determined partly or completely by the thermal stability of the material and the physical form in which it is required. In the pharmaceutical industry, batch sizes are frequently small and of high value and the same dryer may be used to dry different materials. These factors limit the application of continuous dryers and promote the use of batch dryers that give low product retention and are easily cleaned. Recovery of solvents, where economically justified, may be another factor affecting the choice of equipment.

## THE THEORY OF DRYING

Theories of drying are limited in application in that drying times are normally experimentally determined. Nevertheless, an appreciation of the scope and limitations of the different drying methods is given. The following terms are employed in discussing drying: humidity and humidity of saturated air, relative humidity, wet bulb temperature, and adiabatic cooling line. Other terms may be defined as follows:

*Moisture content:* This is usually expressed as a weight per unit weight of dry solids.

*Equilibrium moisture content:* If a material is exposed to air at a given temperature and humidity, it will gain or lose moisture until equilibrium is reached. The

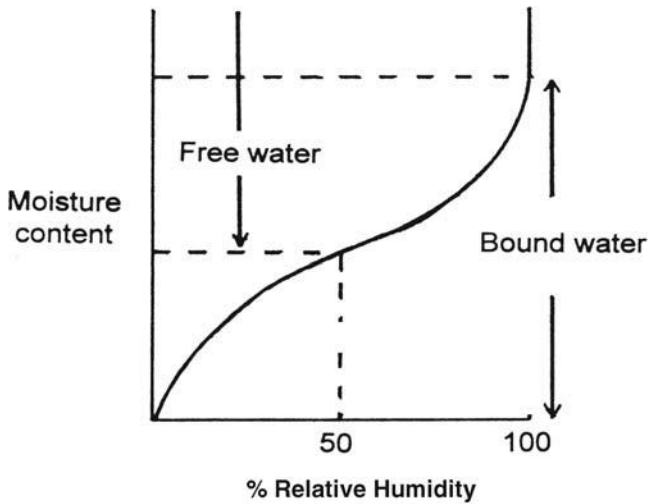

**FIGURE 7.1** The relation between equilibrium moisture content and relative humidity for a hygroscopic solid.

moisture present at this point is defined as the equilibrium moisture content for the given exposure conditions. At a given temperature, it will vary with the partial pressure of the water vapor in the surrounding atmosphere. This is shown for a hypothetical hygroscopic material in Figure 7.1 in which the equilibrium moisture content is plotted against the relative humidity. Any moisture present in excess of the equilibrium moisture content is called “free water.”

Equilibrium moisture content curves vary greatly with the type of material examined. Insoluble, nonporous materials, such as talc or zinc oxide, give equilibrium moisture contents of almost zero over a wide humidity range. A moisture content of between 10% and 15% may be expected for cotton fabrics under normal atmospheric conditions. Drying below the equilibrium moisture content for room conditions may be deliberately undertaken, particularly if the material is unstable in the presence of moisture. Subsequent storage conditions then become important for product stability.

The equilibrium moisture content at 100% relative humidity represents the minimum amount of water associated with the solid that still exerts a vapor pressure equal to a separate water surface. If the humidity is reduced, only part of the water evaporates before a new equilibrium is established. The water retained at less than 100% relative humidity must, therefore, exert a vapor pressure below that of a dissociated water surface. Such water is called “bound water.” Unlike the equilibrium moisture content, bound water is a function of the solid only and not of the surroundings. Such water is usually held in small pores bound with highly curved menisci, is present as a solution, or is adsorbed on the surface of the solid.

The value of equilibrium moisture content curves is illustrated by the examples given in Figure 7.2. The equilibrium moisture content of the antacid granules, composed of magnesium trisilicate granulated with syrup, is a sensitive function of relative humidity. If it is to be dried to a moisture content

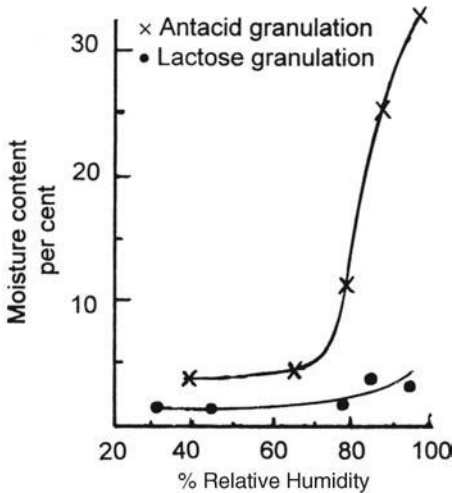

FIGURE 7.2 Equilibrium moisture content curves for two tablet granulations.

of 3%, air at a relative humidity of less than 35% must be used. With knowledge of the humidity of the circulating air, psychrometric charts may be used to determine the minimum air temperature that will dry the material to the required standard. (In fact, the temperature has an effect on the equilibrium moisture content that is independent of the humidity, but this can be neglected to a first approximation.)

The lactose granulation, on the other hand, has a low sensitivity to relative humidity. Drying at low relative humidities derived from high air temperatures causes only a marginal decrease in the final moisture content, and the stability of the active ingredients associated with the lactose filler could be impaired. This argument may only be applied to the final moisture content. It is not related to the rate of drying that would, of course, be greater at higher temperatures and lower humidities.

The effects of storage after drying may also be assessed from the equilibrium moisture content curves. Storage conditions are not critical for the lactose granulation. If the antacid formulation was stored at a relative humidity of only 65%, it would, given sufficient time, absorb moisture until the content was 9%. This could be associated with poor flow characteristics and its attendant difficulties during compression.

Dynamic vapor sorption techniques now exist, which allow thorough studies of moisture association with solids under a wide range of relative humidity conditions based on microbalance technology.

### EVAPORATION OF WATER INTO AN AIRSTREAM

The evaporation of moisture into a warm airstream, the latter providing the latent heat of evaporation, is a common drying mechanism, although it is not easily adapted to the recovery of the liquid. We will consider first evaporation from a liquid surface, which, with the passage of air, falls to the wet bulb temperature corresponding to the temperature and humidity of the air, as described in chapter 6. The rate at which water vapor is transferred from the



saturated layer at the surface to the drying stream is described by equation (4.5) in chapter 4 as:

$$N = \frac{k_g}{RT}(P_{wi} - P_{wa}) \quad (7.1)$$

where  $P_{wi}$  is the partial pressure of the water vapor at the surface and  $P_{wa}$  is the partial pressure of water vapor in the air.  $k_g$  is a mass transfer coefficient, and  $N$  is the number of moles of vapor transferred from unit area in unit time. Rewriting this in terms of the total mass,  $W$ , transferred in unit time from the entire drying surface,  $A$ ,

$$W = \frac{M_w A}{RT} k_g (P_{wi} - P_{wa}) \quad (7.2)$$

where  $M_w$  is the molecular weight of water vapor,  $R$  is the gas constant, and  $T$  is the absolute temperature.

The mass transfer coefficient,  $k_g$ , will itself be a function of the temperature, the air velocity, and its angle of incidence. A high velocity or angle of incidence diminishes the thickness of the stationary air layer in contact with the liquid surface and, therefore, lowers the diffusional resistance.

The rate of evaporation may also be expressed in terms of the heat transferred across the laminar film from the drying gases to the surface. This is described by equation (3.7) in chapter 3 as:

$$Q = hA(T_a - T_s) \quad (7.3)$$

where  $Q$  is the rate of heat transfer,  $A$  is the area of the surface,  $T_a$  and  $T_s$  are the temperatures of the drying air and the surface, respectively, and  $h$  is the heat transfer coefficient. The latter is also a function of air velocity and angle of impingement. If the latent heat of evaporation is  $\lambda$ , this affords a mass transfer rate,  $W$ , which is given by

$$W = \frac{hA}{\lambda}(T_a - T_s) \quad (7.4)$$

Equilibrium drying conditions are represented by the equality of equations (7.2) and (7.4). When these conditions pertain to drying, the surface temperature,  $T_s$ , which is the wet bulb temperature, is normally much lower than the temperature of the drying gases. This is of great importance in the drying of thermolabile materials.

If solids are present in the surface, the rate of evaporation will be modified, the overall effect depending on the structure of the solids and the moisture content.

### STATIC BEDS OF NONPOROUS SOLIDS

Drying of wet granular beds, the particles of which are not porous and are insoluble in the wetting liquid, has been extensively studied. The operation is presented as the relation of moisture content and time of drying in Figure 7.3A. It should be noted that the equilibrium moisture content is approached slowly. A protracted period may be required for the removal of water just above the equilibrium value. This is not justified if a small amount of water can be tolerated in further processing and indicates the importance of establishing

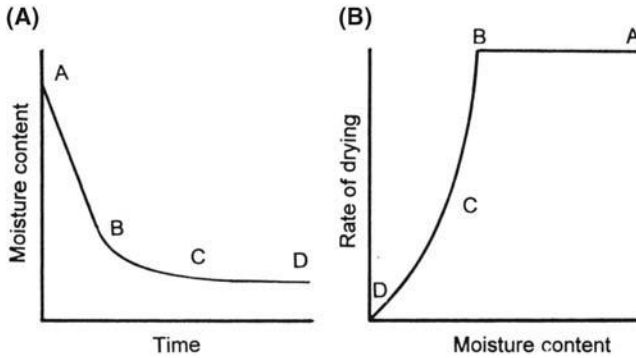

**FIGURE 7.3** (A) Moisture content versus time of drying and (B) rate of drying versus moisture content.

realistic drying requirements. The stability of the solids, maintained, as shown later, at a temperature close to that of the drying air, may allow unnecessary deterioration.

The data has been converted to a curve relating the rate of drying to moisture content in Figure 7.3B. The initial heating-up period during which equilibrium is established is short and has been omitted from both figures.

Assuming that sufficient moisture is initially present, the drying rate curve exhibits three distinct sections limited by the points A, B, C, and D.

In section AB, called the *constant rate period*, it is considered that moisture is evaporating from a saturated surface at a rate governed by diffusion from the surface through the stationary air film in contact with it. An analogy with evaporation from a plain water surface can therefore be drawn. The rate of drying during this period depends on the air temperature, humidity, and speed, which in turn determine the temperature of the saturated surface. Assuming that these are constant, all variables in the drying equations given above are fixed and a constant rate of drying is established, which is largely independent of the material being dried. The drying rate is somewhat lower than that for a free water surface and depends to some extent on the particle size of the solids. During the constant rate period, liquid must be transported to the surface at a rate sufficient to maintain saturation. The mechanism of transport is discussed later.

At the end of the constant rate period, B, a break in the drying curve occurs. This point is called the *critical moisture content*, and a linear fall in the drying rate occurs with further drying. This section, BC, is called the *first falling rate period*. At and below the critical moisture content, the movement of moisture from the interior is no longer sufficient to saturate the surface. As drying proceeds, moisture reaches the surface at a decreasing rate and the mechanism that controls its transfer will influence the rate of drying. Since the surface is no longer saturated, it will tend to rise above the wet bulb temperature.

For any material, the critical moisture content decreases as the particle size decreases. Eventually, moisture does not reach the surface that becomes dry. The plane of evaporation recedes into the solid, the vapor reaching the surface by diffusion through the pores of the bed. This section is called the *second falling rate period* and is controlled by vapor diffusion, a factor which will be largely

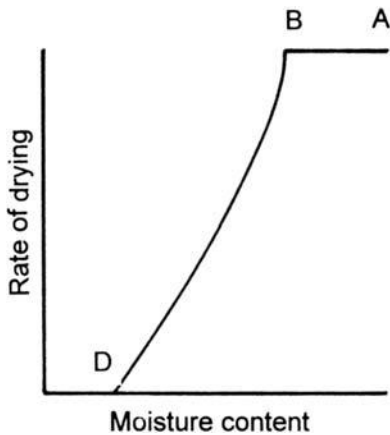

FIGURE 7.4 Drying curve for a skin-forming material.

independent of the conditions outside the bed but markedly affected by the particle size because of the latter's influence on the dimensions of pores and channels. During this period, the surface temperature approaches the temperature of the drying air.

Considerable migration of liquid occurs during the constant rate and first falling rate periods. Associated with the liquid will be any soluble constituents that will form a concentrating solution in the surface layers as drying proceeds. Deposition of these materials will take place when the surface dries. Considerable segregation of soluble elements in the cake can, therefore, occur during drying.

If the soluble matter forms a skin or gel on drying rather than a crystalline deposit, a different drying curve, shown in Figure 7.4, is obtained. The constant rate period is followed by a continuous fall in the drying rate in which no differentiation of first and second falling rate periods can be made (hence "C" is not identified in Fig. 7.4). During this period, drying is controlled by diffusion through the skin that is continually increasing in thickness. Soap and gelatin are solutes that behave in this way.

### THE INTERNAL MECHANISM OF DRYING

Extensive studies have been made to determine the nature of the forces that initially convey moisture to the surface at a rate sufficient to maintain saturation and their subsequent failure. Movement of liquid may occur by diffusion under the concentration gradient created by depletion of water at the surface by evaporation, as the result of capillary forces, through a cycle of vaporization and condensation, or by osmotic effects. Of these, capillary forces offer a coherent explanation for the drying periods of many materials.

If a tapered capillary is filled with water and exposed to a current of air, the meniscus at the smaller end remains stationary while the tube empties from the wider end. A similar situation exists in a wet particulate bed, and the phenomenon is explained by the concept of suction potential. A negative pressure exists below the meniscus of a curved liquid surface, which is proportional to the surface tension,  $\gamma$ , and inversely proportional to the radius of curvature,  $r$ . (The meniscus is assumed to be a part of a hemisphere.) This

negative pressure or suction potential may be expressed as the height of liquid,  $h$ , it will support:

$$h = \frac{2\gamma}{\rho g r} \quad (7.5)$$

where  $\rho$  is the density of the liquid.

The suction potential,  $h_x$ , acting at a depth  $x$  below the meniscus will then be given by

$$h_x = h - x \quad (7.6)$$

The particles of the bed enclose spaces or pores connected by passages, the narrowest part of which is called the waist. The dimensions of the latter will be determined by the size of the surrounding particles and the manner in which they are packed. In a randomly packed bed, pores and waists of varying sizes will be found. Thus, the radius of a capillary running through the bed varies continuously. The depletion of water in this network will be controlled by the waists because the radii of curvature will be smaller and the suction potentials greater than that for the pores. Depletion occurs in the following way. As evaporation proceeds, the water surface recedes into the waists of the top layer of particles, and a suction potential develops. The maximum suction potential a waist can develop is called its "entry" suction potential, and this will be exceeded for the larger waists by the suction potential developed by the smaller waists and transmitted through the continuous, connecting thread of liquid. The menisci in the larger waists will collapse and the pores they protect will be emptied, that is, assuming an interconnecting thread of liquid, a surface waist developing a suction potential,  $h_s$ , will cause the collapse of an interior waist developing a suction potential  $h_i$  and distance  $x$  below the surface if  $h_s > h_i + x$ . The liquid in the exposed pores is then lost at the surface by evaporation. This effect will continue until a waist provides an opposing suction potential that is equal to or greater than the suction potential provided at that depth by the fine surface waist meniscus. The latter then collapses, and the pore it protects is emptied.

By this mechanism, a meniscus in a fine surface waist will hold its position and deplete the interior of moisture. If sufficient full surface waists are present, the constant rate period is maintained since the stationary air film in contact with the bed can be saturated. The first falling rate period indicates that insufficient full surface waists are present. Eventually, the collapse of all surface waists takes place, giving a breakdown of the capillary network supplying moisture to the surface, and the second falling rate period ensues.

### STATIC BEDS OF POROUS SOLIDS

The drying curve obtained when the particles that compose the bed are themselves porous is shown in Figure 7.5. It differs from the curve obtained with nonporous materials in that the constant rate period is shorter. The rate of drying may be higher and is almost independent of particle size. The critical moisture content is a function of both pore size and particle size. During the first falling rate period, the rate of drying falls steeply because, it is thought, of the drying of the surface granules. The second falling rate period is influenced by the diffusion of moisture from within the particles.

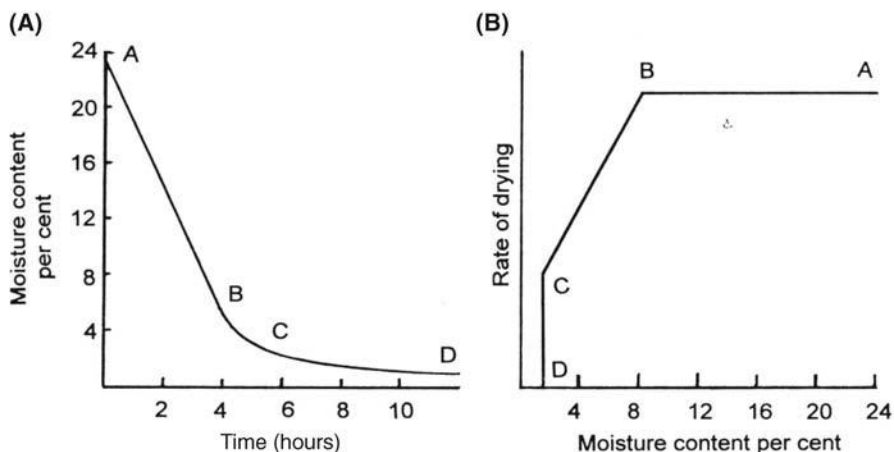

**FIGURE 7.5** Drying curves for a tablet granulation dried in a tray drier (A) moisture content versus time and (B) drying rate versus moisture content.

### THROUGH-CIRCULATION DRYING

If the particles are in a suitable granular form, it is often possible to pass the airstream downward through the bed of solids. Drying will then follow the pattern described in previous sections except that each particle or agglomerate behaves as a drying bed. The surface area exposed to the drying gases is greatly increased and drying rates 10 to 20 times greater than those encountered when air is passed over a free surface are obtained.

### METHODS INVOLVING MOVEMENT OF THE SOLID

As an extension of drying by passing the airstream through a static bed of solids, it is possible to project air upward through the bed at a velocity high enough to fluidize the particles. Alternatively, the material may be mechanically subdivided and then introduced into the drying stream. Both methods give high drying rates due to high interfacial contact between the drying surfaces and the airstream. Fluidized bed dryers and spray dryers, respectively, use these principles.

### OTHER METHODS OF DRYING

Apart from specialized dryers using infrared or dielectric heating, the chief method of passing heat into a drying solid, other than from a hot airstream, is by conduction from a heated surface. When a wet solid is placed in contact with a hot surface, subsequent events depend on the temperature of the surface relative to the boiling point of the liquid, the nature of the solid, and the method of heating the surface. It is assumed here that the temperature of the surface is not hot enough for convective boiling to take place.

Consider first a cake of finely divided solids saturated with water. A temperature gradient will be established through the cake and evaporation from the free surface will take place at a rate governed entirely by the rate of heat

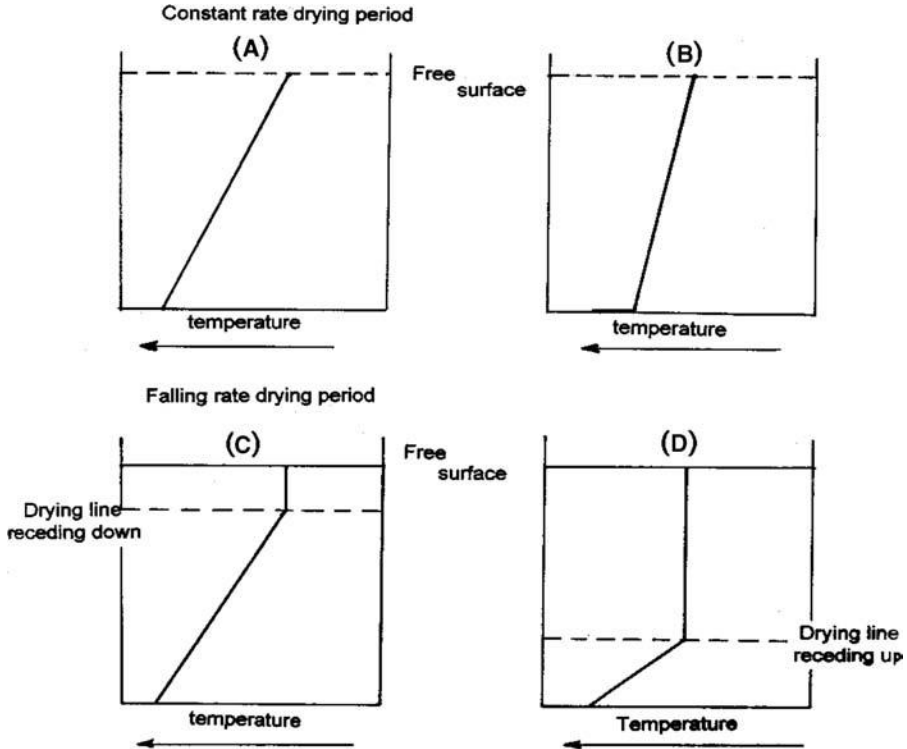

FIGURE 7.6 Drying by conduction of heat from a heated surface.

input. During this period, the rate of evaporation and the temperature of a particular layer of cake will be approximately constant. This will continue until capillary forces are unable to transfer liquid to the free surface at the required rate. The temperature gradients during this period are given in Figure 7.6A and B for conditions in which the shelf temperature is below and above the boiling point of the liquid, respectively.

With a comparatively low heat flux, so that the partially dried cake can conduct heat away from the hot surface at the required rate, the free surface will dry and a fictitious drying line will recede slowly into the cake, the vapor diffusing through the dry cake to the free surface. The temperature gradient during this falling rate period is shown in Figure 7.6C. If the heat flux is high, the point at which mobile water can no longer reach the surface is marked by the onset of drying in a layer adjacent to the hot surface, and vapor is forced through the wet cake above. As the solid dries, its temperature increases and a temperature gradient is established through the dry solids to the drying line that is receding upward. This is shown in Figure 7.6D. The free surface of the solid appears wet and is at a constant temperature. These conditions are destroyed when the drying line reaches the surface.

In either case, a low and falling rate of drying will persist as the absorbed water is removed. In this form of drying, the heat treatment received by the solid is not uniform but depends on its position in the cake.

A hot surface may also be used to dry solutions, such as milk or plant extracts, which do not readily give porous, crystalline solids on concentration. Apart from an initial constant rate period, when heat transfer is mainly convective, drying periods are ill defined. As concentration proceeds, the liquor becomes more viscous and heat transfer is mainly by conduction. Large volume changes occur between initial and final stages. It is possible to dry thin films of solution to a solid film, but if deeper layers are taken, a skin is frequently formed at the free surface that is almost impervious to the vapor. Frothing and drying to a porous, friable structure will then occur. This may also happen if, during the upward recession of the drying line, the material above is too viscous to allow the escape of vapor.

### SOLIDS MOVING OVER A HOT SURFACE

Conditions in which the solids move over a heated surface are employed in tumbling and agitated dryers. Drying rates are higher than those obtained in static beds because fresh solids are continually exposed to the hot surface. The heat treatment received by the solid will be more uniform.

### BATCH DRYERS

#### Hot Air Ovens

Ovens operating by passing hot air over the surface of a wet solid that is spread over trays arranged in racks provide the simplest and cheapest dryer. On small installations, the air is passed over electrically heated elements and once through the oven. Larger units may employ steam-heated, finned tubes, and thermal efficiency is improved by recirculating the air. This is controlled by manually set dampers, and a common operating position gives 90% recirculation and 10% bleed-off. The heater bank is placed so that the solids do not receive radiant heat and incoming air may be filtered. A typical hot air oven is illustrated schematically in cross section in Figure 7.7A.

The temperature-humidity sequence of the circulating drying air is presented in Figure 7.7B. The incoming air, at a temperature and humidity given by point A, is heated at constant humidity to point B and passed over the wet solid. The humidity rises and the temperature falls as the adiabatic cooling line is followed until the air leaves the tray in condition C. It is then recirculated to the heater, and in Figure 7.7B, two further cycles are shown.

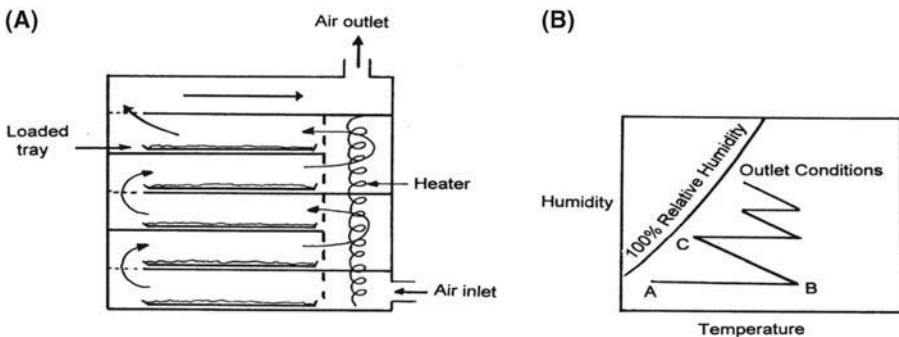

FIGURE 7.7 (A) A tray dryer. (B) Temperature-humidity sequence of drying air.

We have assumed that all heat is drawn from the air and transmitted across the stationary air layer in contact with the drying surface, as described earlier. Surface temperatures are, in fact, modified by heat absorbed and conducted from unwetted surfaces, such as the underside of the tray, and by radiation.

The chief advantage of the hot air oven, apart from its low initial cost, is its versatility. With the exception of dusty solids, materials of almost any other physical form may be dried. Thermostatically controlled air temperatures of between 40°C and 120°C permit heat-sensitive materials to be dried. For small batches, a hot air oven is, therefore, often the plant of choice. However, the following inherent limitations have led to the development of other small dryers:

1. A large floor space is required for the oven and tray-loading facilities.
2. Labor costs for loading and unloading the oven are high.
3. Long drying times, usually of the order of 24 hours, are necessary.
4. Solvents can be recovered from the air only with difficulty.
5. Unless carefully designed, nonuniform distribution of air over the trays gives variation in temperature and drying times within the oven. Variations of  $\pm 7^\circ\text{C}$  in temperature have been found from location to location during the drying of tablet granules. Poor air circulation may permit local saturation and the cessation of drying.

If the material is of suitable granular form, drying times may be reduced to an hour or less by passing the air downward through the material laid on mesh trays. The oven in this form is called a batch through-circulation dryer.

### Vacuum Tray Dryers

Vacuum tray dryers, as shown in Figure 7.8A, differing only in size from the familiar laboratory vacuum ovens, offer an alternative method for drying small quantities of material. When scaled up, construction becomes massive to

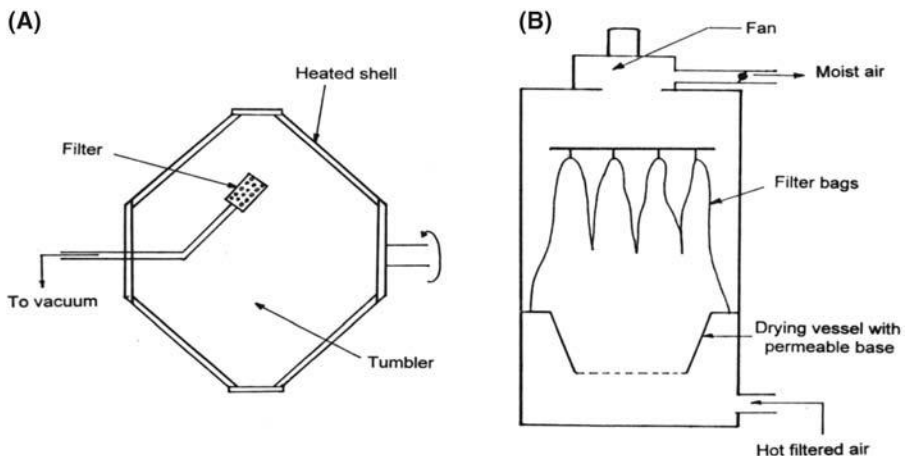

FIGURE 7.8 (A) Rotary vacuum dryer and (B) fluidized bed dryer.



withstand the applied vacuum, and cost is further increased by the associated vacuum equipment. Vacuum tray dryers are, therefore, only used when a definite advantage over the hot air oven is secured, such as low-temperature drying of thermolabile materials or the recovery of solvents from the bed. The exclusion of oxygen may also be advantageous or necessary in some operations.

Heat is usually supplied by passing steam or hot water through hollow shelves. Drying temperatures can be carefully controlled, and for the major part of the drying cycle, the material remains at the boiling point of the wetting liquid under the operating vacuum. Radiation from the shelf above may cause a significant increase in temperature at the surface of the material if high drying temperatures are used. Drying times are long and usually of the order of 12 to 48 hours.

### **Tumbling Dryers**

The limitations of ovens, particularly with respect to the long drying times, have, where possible, promoted the design and application of other batch dryers. The simplest of these is the tumble drier for which the most common shape is the double cone shown in Figure 7.8A. Operating under vacuum, this provides controlled low-temperature drying, the possibility of solvent recovery, and increased rates of drying. Heat is supplied to the tumbling charge by contact with the heated shell and by heat transfer through the vapor. Optimum conditions are established experimentally by varying the vacuum, the temperature, and, if the material passes through a sticky stage, the speed of rotation. With correct operation, a uniform powder should be obtained as distinct from the cakes produced when static beds are dried. Some materials, such as waxy solids, cannot be dried by this method because the tumbling action causes the material to aggregate into balls.

A normal charge would be about 60% of the total volume, and for dryers 0.7 to 2 m in diameter, drying times of 2 to 12 hours may be expected. In studying the application of tumbler dryers to drying tablet granules, it was found that periods of 2 to 4 hours replaced times of 18 to 24 hours obtained with hot air ovens. The mixing and granulating capacity of the tumbling action has suggested that these operations could precede drying in the same apparatus.

### **Fluidized Bed Dryers**

The term "fluidization" is applied to processes in which a loose, porous bed of solids is converted to a fluid system having the properties of surface leveling, flow, and pressure-depth relationships by passing the fluid up through the bed.

Fluidized bed techniques, employing air as the fluidizing medium, have been successfully applied to drying when the solid is of suitable physical form. The high interfacial contact between drying air and solids gives drying rates 10 to 20 times greater than that obtained during tray drying. A drying curve for this method is shown in Figure 7.9.

The dryer, illustrated in Figure 7.8B, consists of a basket of either plastic or stainless steel with a perforated bottom, which is mounted in the body of the drier and into which the material to be dried is placed. Heated air may be either blown or sucked through the bed. The air leaving the basket passes through an air filter and may be recirculated. Particle properties, such as shape and size distribution, affect fluidization, and a unit must have a variable air flow adjusted

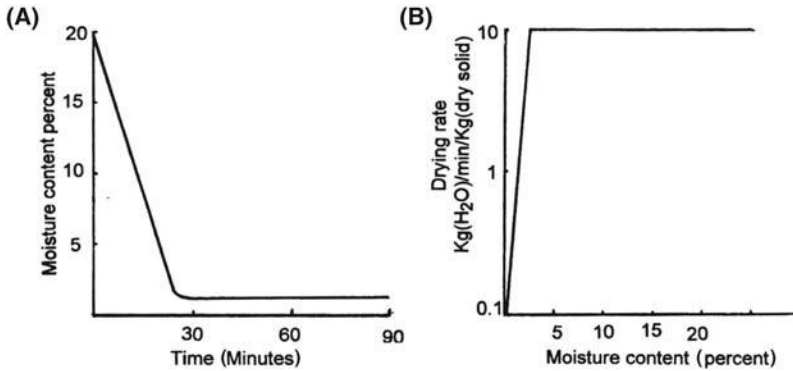

FIGURE 7.9 Drying curves.

so that the material is fluidized but is not carried into the filters. For this reason, the material must have a fairly close size range or else elutriation of fine particles into the filters will take place.

Fluidized bed dryers are particularly suitable for granulated materials and are being increasingly used for tablet granulations provided product changeover is not too frequent. It may be advantageous to preform other materials, such as a dewatered filter cake, into granules solely to employ fluidized bed drying. If fluidizing conditions are ideal, the granulation will not require further grinding. Tray dryers, on the other hand, produce a caked product that may require mild comminution. Variation in temperature, which may be quite marked in tray dryers, is virtually eliminated in fluidized bed dryers by the intense mixing action. The floor space for a given capacity is smaller compared with a tray dryer. Machines vary in size, handling up to 250 kg. Drying times, maximum, minimum, and optimum air velocities, air temperature, and the tendency to cake and channel are established experimentally as these cannot be predicted accurately at present.

Considerable erosion and the production of large amounts of fines might be expected from the intense turbulent movement. Experience shows that the opposite is true. The particles are to some extent "padded" by the surrounding fluid so that either the amount of contact between particles is low or the impact energy is small.

### Agitated Batch Dryers

Agitated batch dryers consist of a jacketed cylindrical vessel with agitator blades designed to scrape the bottom and the walls. The body may be run at atmospheric pressure or under vacuum. Pasty materials, which could not be handled in tumbling or fluidized bed dryers, may be successfully dried at rates higher than that can be achieved in an oven.

### Freeze-Drying

Freeze-drying is an extreme form of vacuum drying in which the solid is frozen and drying takes place by subliming the solid phase (Dushman and Lafferty, 1962; Jennings, 1988; Nail, 1980; Pikal et al., 1984). Low temperatures and

pressures are used. Establishing and maintaining these conditions, together with the low drying rates obtained, create a most expensive method of drying, which is only used on a large scale when other methods are inadequate.

There are two principal fields in which freeze-drying is extensively used. It is used when high rates of decomposition occur during normal drying. The second field concerns substances that can be dried at higher temperatures but are thereby changed in some way. Fruit juices, for example, are reputed to lose subtle elements of flavor and odor, and proteinaceous materials are partly denatured by the concentration and higher temperatures associated with conventional drying. Drying of blood plasma and some antibiotics are important large-scale applications of freeze-drying. On a smaller scale, it is extensively used for the dehydration of bacteria, vaccines, blood fractions, and tissues.

Freeze-drying is theoretically a simple technique. Pure ice exhibits an equilibrium vapor pressure of 4.6 mmHg at 0°C and 0.1 mmHg at -40°C. The vapor pressure of ice containing dissolved substances will, of course, be lower. If, however, the pressure above the frozen solution is less than its equilibrium vapor pressure, the ice will sublime, eventually leaving the solute as a sponge-like residue equal in apparent volume to the original solid and, therefore, of low bulk density. The latter is readily dissolved when water is added, and freeze-drying has been called "lyophilic drying" or "lyophilization" for this reason. No concentration, in the normal sense of the word, occurs, and structural changes in, for example, protein solutions, are minimized.

In practice, many difficulties are encountered. Under conditions of high vacuum, water vapor must be trapped or eliminated. To maintain drying, heat must be supplied to the frozen solid to balance the latent heat of sublimation without melting the frozen solid. Difficulties become acute if, like blood plasma, the product is dried in the final container under aseptic conditions.

In the first stage of the process, the material is cooled and frozen. If the temperature of a dilute solution of a salt is slowly reduced, leveling occurs in the time-temperature curve just below 0°C because of the liberation of the latent heat of fusion of ice, and pure ice separates. With further cooling, the solution becomes concentrated until the eutectic mixture is formed. This freezes to give a plateau in the cooling curve. It is a clear indication of complete freezing. If the concentration of the liquid eutectic mixture is small, the material may appear to be completely frozen at higher temperatures. Under these conditions, some drying from a liquid phase will occur, possibly with damaging results. This can be detected by measuring the electrical resistance of the ice that becomes infinitely great when the eutectic mixture freezes. Conversely, thawing gives a marked decrease in resistance, an effect that can be used to automatically control the state of the drying solid. Protein solutions do not give clearly defined eutectic points and are usually frozen to below -25°C before drying. Freezing is carried out quickly to prevent concentration of the solution and to produce fine ice crystals. Some degree of supercooling may be induced, followed by a very quick freeze. Freezing may or may not be carried out in the drying chamber. If drying in final containers is necessary, small-scale operations may employ immersion in a coolant such as liquid air or isopentane. Larger-scale installations may cool with a blast of very cold air. Alternatively, evaporative freezing, in which the liquid is cooled to near its freezing point and the system is rapidly evacuated, is employed. The evaporating liquid cools and freezes rapidly. Frothing caused by the evolution of dissolved gases may complicate this

technique. For bulk drying, the liquid is placed in shallow trays on refrigerated shelves in the drying cabinet.

A suitable surface area to depth of solid ratio must be provided to facilitate drying. Thin layers of frozen liquid are used in bulk drying. The surface area of bottle-dried plasma may be increased by spinning in a vertical axis during freezing to give a frozen shell about 2 cm thick around the inside periphery of the bottle. Spinning also prevents frothing during evaporative freezing by inhibiting the formation of bubbles.

In plasma processing, freezing, and drying, handling must be carried out aseptically. This is maintained by a filter at the neck of the bottle that allows the passage of water vapor but prevents the ingress of bacteria. Similar precautions are taken during the drying of antibiotics.

Effective drying vacuum of 0.05 to 0.2 mmHg may be provided by directly pumping water vapor and permanent gases, originally present or derived from the drying material and from leaks, out of the system. Normal practice, however, favors interposing a refrigerated condenser between the drying surface and the pump. This arrangement allows a smaller pump, handling mainly permanent gases, to be used but demands a low condenser temperature, such as  $-50^{\circ}\text{C}$ , to remove water vapor at the low operating pressure. A system for bulk drying in trays is represented diagrammatically in Figure 7.10A.

During drying, heat must be supplied to the drying surface. When drying a material, such as plasma, in a final container, a temperature gradient is established across the container wall and through the ice to the drying surface by means of a heater suitably mounted in relation to the container. The power dissipated by the heater must be carefully controlled so that melting does not occur at the ice-container junction, the point nearest to the heat source and at the highest temperature. At any time, the conditions prevailing are such that the rate of evaporation is approximately constant and temperatures and pressure adjust so that there is a temperature and pressure gradient from the drying surface to the condenser. As evaporation proceeds, a drying line recedes into the solid. With the thinning of the ice layer, the temperature gradient through the ice will be modified by the decreasing resistance to heat flow. An increase in the rate of drying due to increase in temperature and vapor pressure of the drying surface might, therefore, be expected. In practice, this is modified by the layer of dried plasma that offers considerable resistance to the flow of vapor.

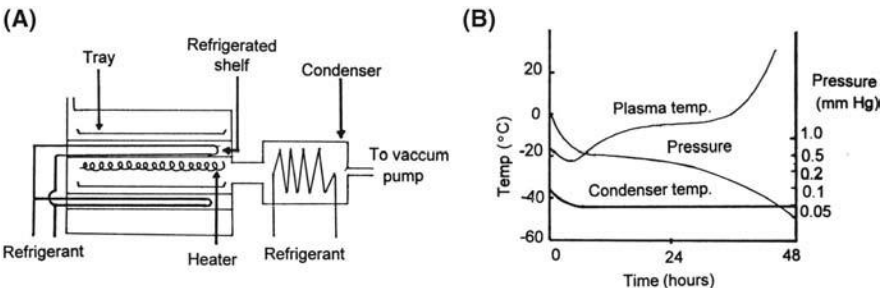

**FIGURE 7.10** (A) Equipment for freeze-drying bulk liquids in trays and (B) variations in temperature and pressure during the freeze-drying cycle for blood plasma.

The bacterial filter also causes a large, constant pressure drop. Evaporation of pure ice without the filter and plasma layer would be 300 times faster. When the plasma is nearly dry, its temperature is allowed to rise to about 30°C to facilitate final drying. The total drying time is about 48 hours. The temperatures and pressure in the system during this period are shown, as a function of time, in Figure 7.10B.

If the product is not being dried in its final container, radiant heat may be used to provide the latent heat of sublimation. If the dried solid could be removed continuously, high drying rates are possible. Not only is heat provided directly to the drying surface, but there is also little danger of melting the ice at the container wall.

### CONTINUOUS DRYERS

Although many types of continuous dryers are available, the scale of the operation for which they are designed is rarely appropriate for pharmaceutical manufacture. As with most continuous plant items, the cost is disproportionately high for small units. Spray and drum dryers provide an exception to this comment because residence times in the dryers are short and thermal degradation is minimized. Under some conditions, freeze-drying may be the only practicable alternative.

#### Spray Dryers

As the name implies, the solution or suspension to be dried is sprayed into a hot airstream and circulated through a chamber. The dried product may be carried out to cyclone or bag separators or may fall to the bottom of the drying chamber and be expelled through a valve. The chambers are normally cylindrical with a conical bottom, although proportions vary widely. A typical spray dryer is illustrated in Figure 7.11 (Masters, 1991; Sacchetti and Van Oort, 2006).

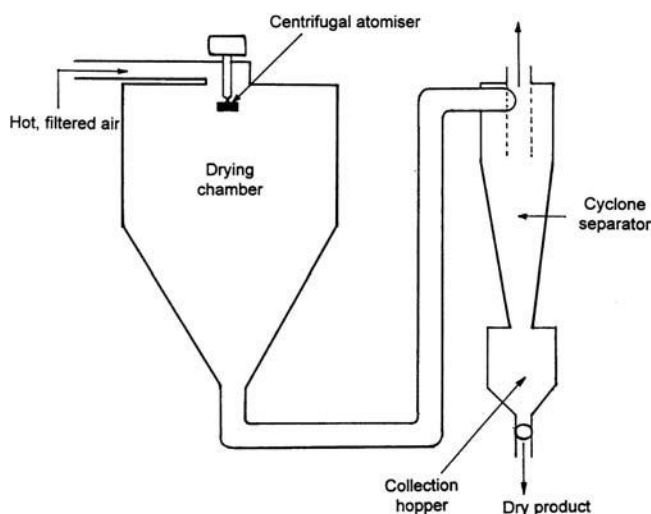
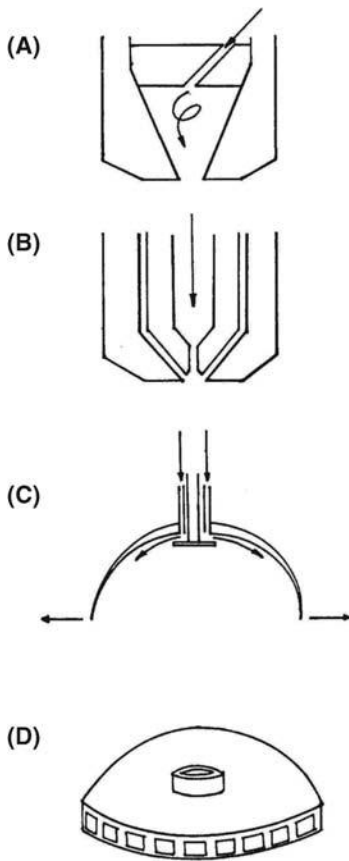

FIGURE 7.11 Spray dryer.



**FIGURE 7.12** Schematic diagrams of atomizers for spray drying.

The process can be divided into four sections: atomization of the fluid, mixing of the droplets, drying, and, finally, removal and collection of the dry particles.

Atomization may be achieved by means of single fluid or two fluid nozzles or by spinning disk atomizers. The single fluid nozzle, illustrated in Figure 7.12, operates by forcing the solution under pressure through a fine hole into the airstream. An intense swirl is conferred on the liquid before it emerges from the orifice. This causes the jet to break up. In the two fluid nozzles, shown in Figure 7.12, a jet of air simultaneously emerges from an annular aperture concentric with the liquid orifice. Both types are subject to clogging and severe erosion, so neither is well suited to spraying suspensions. The spinning disks are most versatile and consist, in their simplest form, of a mushroom-shaped disk spinning at 5000 to 30,000 rpm. Other designs include the slotted disk (Fig. 7.12), which will spray thick suspensions and, if special feeding arrangements are used, pastes. The main factors that determine the size of the droplets are the viscosity and surface tension of the liquid, the fluid pressure in the use of nozzles, or, for spinning disks, their size and speed of rotation. A reasonably uniform and controllable size within the range 10 to 500  $\mu\text{m}$  is desirable.

In vertical spray dryers, the flow of the drying gas may be concurrent or countercurrent with respect to the movement of droplets. The movement of the gas is, however, complex and highly turbulent. Good mixing of droplets and gas occurs, and the heat and mass transfer rates are high. In conjunction with the large interfacial area conferred by atomization, these factors give very high evaporation rates. The residence time of a droplet in the dryer is only a few seconds (5–30 seconds). Since the material is at wet bulb temperature for much of this time, high gas temperatures of 150°C to 200°C may be used even with thermolabile materials. Although the temperature of the material rises above the wet bulb temperature at the end of the process, the drying gases will be cooler and the material will be almost dry, a condition in which many materials are thermally less sensitive. For these reasons, it is possible to dry complex vegetable extracts, such as coffee or digitalis, milk products, spore suspensions, and other labile materials without significant loss of potency or flavor.

Drying is considered to take place by simple evaporation rather than by boiling, and it has been observed that a droplet reaches a terminal velocity within about 30 cm of the atomizer. Beyond this, there is no relative velocity between the droplet and the drying gas unless the former is very large. The droplets may dry to form a solid, spherical particle. If, however, the emerging solids form a skin, internal pressure may inflate the particle, and the final dry form will be hollow spheres that may or may not have a blow hole. These xenospheres may also fragment so that the final product occurs as agglomerates of finely divided solids. It has been found experimentally that the product's bulk density, which is lowest for xenospheres and highest for fragmented solids, increases as the inlet air temperature is lowered and as the drop size increases. A higher feed concentration also increases the bulk density because drops of the same size give spheres with thicker walls.

These attractive physical characteristics lend further advantage to spray drying. The product often has excellent flow and packing properties that greatly facilitate handling and transport. As an example, spray-dried lactose is a widely used tablet excipient, which will flow, pack, and compact without prior granulation. Similarly, a slurry of fillers and other excipients could be granulated by spraying and drying. After adding an active principle, the mix could be compressed without further processing.

The capital and running costs of spray dryers are high, but if the scale is sufficiently large, they may provide the cheapest method. When thermolabile materials are dried on a small scale, costs will be 10 to 20 times greater than that for oven drying. Air used to dry fine chemicals or food products is heated indirectly, thus reducing thermal efficiency and increasing costs. In some other installations, hot gases from combustion may be used directly.

### **Drum Dryers**

The drum dryer consists of one or two slowly rotating, steam-heated cylinders. These are coated with solution or slurry by means of a dip feed, illustrated in Figure 7.13, in which the lower portion of the drum is immersed in an agitated trough of feed material or, in the case of some double drum dryers, by feeding the liquor into the gap between the cylinders, as shown in Figure 7.13. Spray and splash feeds are also used. When dip feeding is employed, the hot drum must not boil the liquid in the trough. Drying takes place by simple evaporation rather

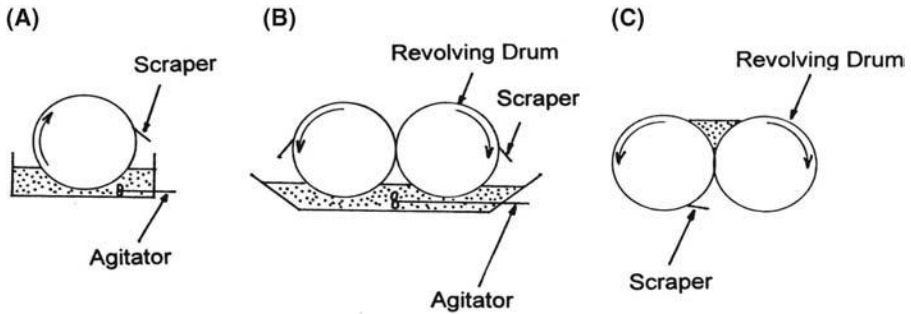

**FIGURE 7.13** Drum dryers.

than by boiling. The dried material is scraped from the drum at a suitable point by a knife.

Drying capacity is influenced by the speed of the drum and the temperature of the feed. The latter may be preheated. With the double drum dryer, the gap between the cylinders determines the thickness of the film.

Drum dryers, like spray dryers, are relatively expensive in small sizes, and their use in the pharmaceutical industry is largely confined to drying thermolabile materials where the short contact time is advantageous. Drums are normally fabricated from stainless or chrome-plated steel to reduce contamination. The heat treatment to which the solid is subjected is greater than that in spray drying, and the physical form of the product is often less attractive. During drying, the liquid approaches its boiling point and the dry solids approach the temperature of the drum surface.



**INTRODUCTION**

Leaching or solid-liquid extraction are terms used to describe the extraction of soluble constituents from a solid or semisolid by means of suitable solvents. The process, which is used domestically whenever tea or coffee is made, is an important stage in the production of many fine chemicals found naturally in animal and vegetable tissues. Examples are found in the extraction of fixed oils from seeds, this method offering an alternative to mechanical expression, in the preparation of alkaloids, such as strychnine from *Nux vomica* beans or quinine from *Cinchona* bark, and in the isolation of enzymes, such as renin, and hormones, such as insulin, from animal sources. In the past, a wider importance attended the process because the products of simple extraction procedures, known as galenicals, formed the major part of the ingredients used to fulfill a doctor's prescription.

**METHODS OF LEACHING**

Leaching in the pharmaceutical and allied industries is operated as a batch process. This is because high-cost materials are processed in relatively small quantities. Frequent changes of material may be made, creating problems of cleaning and contamination. For these reasons, continuous extraction, which is characterized by a large throughput and the mechanical movement of the solid counter to the flow of solvent, is not applicable to pharmaceutical extraction and is not described in this text.

Whatever the scale of the extraction, however, leaching is performed in one of two ways. In the first, the raw material is placed in a vessel, forming a permeable bed through which the solvent or menstruum percolates. Dissolution of the wanted constituents occurs, and the solution issues from the bottom of the bed. This liquid is sometimes called the miscella, and the exhausted solids are called the marc. This process is called leaching by percolation. The alternative process is leaching by immersion and consists of immersing the solid in the solvent and stirring. After a suitable period of time, solid and liquid are separated.

**LEACHING BY PERCOLATION**

Coarse ground material is placed in the body of the extractor. This may be jacketed to give control of the extraction temperature. The packing must be even or else the solvent will preferentially flow through a limited volume of the bed and leaching will be inefficient. In large extractors, channeling is prevented or reduced by horizontal, perforated plates placed at intervals in the bed. These redistribute the percolating liquid.

Solvent inhibition will swell dried materials, and the permeability of the bed will be reduced. This is most marked with aqueous solvents. If swelling occurs, it is necessary to moisten the material with water or with the solvent before it is packed into the extractor.

Once the extractor is packed, leaching may be conducted in a number of ways. The body of the extractor may be completely filled with the solvent. Liquid is then withdrawn from the body through the false bottom, and more solvent is added. This is continued until the marc is exhausted. Alternatively, the solution issuing from the bottom may be returned to the top. After a period of recirculation, the liquid is completely withdrawn, and fresh solvent is admitted. In both processes, a period of steeping or soaking may precede the movement of liquid.

In beds of high permeability, adequate movement of liquid is obtained by simple gravity operation in an open vessel. If the material forms a dense bed, however, the liquid must be pumped through if suitable flow rates are to be secured. A closed extraction vessel must then be used. Closed extraction vessels are also necessary for high-temperature extraction and extraction with volatile solvents. In alternative methods, the liquid is forced upward through the bed. Possible migration of fine material downward and the formation of a region of low permeability at the bottom of the bed are prevented in this way. In other processes, the bed may not be immersed in the menstruum. This is simply sprinkled on to the upper surface and allowed to trickle through the bed, the voids of which are mainly filled with air.

Simple extractions of this type will, if carried to completion, require large amounts of solvent and yield dilute extracts. These disadvantages can be overcome if extraction is followed by evaporation. These operations are often integrated in extraction plant. The leach liquids leaving the extractor enter an evaporator heated, for example, by a calandria. Since most materials encountered are heat sensitive, this will be operated at reduced pressure. The vapor leaving the evaporator is condensed and returned to the extractor. When extraction is carried out with water-immiscible solvents, any water derived from the feed material and present in the condensate would be separated and rejected. The extraction is stopped when the leach liquid is free from wanted constituents. A concentrated extract remains in the evaporator.

Leaching by percolation provides a simple method of separating leach liquid and solid during the extraction. When this is complete, the permeable bed will largely drain, permitting extensive solvent recovery. Further recovery can be gained by mechanical expression.

### **LEACHING BY IMMERSION**

In pharmaceutical processes, leaching by immersion is carried out in simple tanks, which may be agitated by a turbine or paddle. If the solids are adequately suspended, intimate contact between the phases promotes efficient extraction. Incomplete extraction due to channeling is avoided, and difficulties due to swelling do not arise. Problems arise, however, in the subsequent separation of the phases. The materials to which leaching by immersion is applied are normally either finely divided or coarse and compressible. When agitation ceases, the solids will settle and the leach liquid can be siphoned or pumped off by lines suitably placed in the tank. The sediment will, however, contain a large volume of the leach liquid, which must be recovered by resuspending the solids in fresh solvent, allowing the solids to sediment and decanting the supernatant liquid. Cake filtration provides an alternative method of separation. The leach liquid remaining in the cake is displaced by passing a wash liquid. In some cases, a filter press may be used for both extraction and separation.

### THE CHOICE OF EXTRACTION METHOD

The choice of extraction method depends primarily on the physical properties of the basic material and its particle size. If this material is a coarse, rigid powder, beds of high permeability will form and percolation can be adopted. The expense of finer grinding is avoided and the subsequent separation of solids and liquid is facilitated. The process can be conducted in such a way that a concentrated product is obtained. Other materials, such as fine powders or compressible animal tissues, will not form permeable beds, and the alternative method must be adopted. Some compensation for the difficulties of separation and the dilution of the extract during washing may be found in a more rapid and more complete extraction. This is due to the use of finer powders, intimate contact between solids and liquid, and the absence of channeling.

The use of pressure extends the application of percolation to materials that form beds of low permeability. Alternatively, permeability may be increased by grinding the solids with a supporting material such as glass wool.

### THE CHOICE OF SOLVENT

The ideal solvent is cheap, nontoxic, and nonflammable. It is highly selective, dissolving only the wanted constituents of the solid. It should have a low viscosity, allowing easy movement through a bed of solids, and, if the resulting solution is to be concentrated by evaporation, a high vapor pressure. These factors greatly limit the number of solvents of commercial value. Water and alcohol, and mixtures of the two are widely used. Both, however, are non-selective leaching varying proportions of gums, mucilages, and other unwanted components. Most of the tinctures and liquid extracts used in pharmacy are simple, impure extracts made with water or mixtures of water and alcohol. Acidified or alkaline mixtures of water and alcohol are used to extract insulin from minced pancreas. A more selective extraction is given by petroleum solvents and benzene and related solvents. In the preparation of many pure alkaloids, the powdered material is moistened with an alkaline solution, packed into a bed, and leached with petroleum. Subsequent purification by fractional crystallization is facilitated by the absence of gums. Acetone and chlorinated hydrocarbons also find applications in leaching. In some cases, specific properties of the wanted constituents may suggest a particular solvent. Eugenol, for example, can be readily extracted from cloves with a solution of potassium hydroxide.

### FACTORS AFFECTING THE RATE OF LEACHING

Whatever method is adopted, leaching consists of a number of consecutive diffusional or mass transfer processes. The solvent first penetrates the raw material and dissolution of the soluble elements occurs. These diffuse in the opposite direction to the surface of the solid matrix and then through the liquid layers at its surface to reach the bulk solution. These processes proceed under the influence of an overall concentration gradient, the concentration being least in the bulk solution. Any of these processes may be responsible for limiting the rate at which leaching proceeds. In pharmaceutical leaching, however, the solid matrix is usually cellular and this structure will normally offer the highest diffusional resistance. The complexity of such structures does not permit a strict analysis of the processes of mass transfer. Nevertheless, the simple diffusional

concepts expressed in Fick's law suggest that the following factors will influence the rate of leaching: the size distribution of the leached particles, the temperature of leaching, the physical properties of solvent, and the relative movement imposed on the solids and the liquid.

### **THE SIZE AND SIZE DISTRIBUTION OF THE SOLID PARTICLES**

The particle size of the solids determines the distance that solvent and solute must diffuse within the solid matrix. Since this offers the major diffusional resistance, reduction of the distance by comminution greatly increases the rate of leaching, the concentration gradient being effectively increased. In addition, the inverse relationship between particle size and surface area prescribes an increase in the area of contact between the matrix and the surrounding liquid. Transfer of solute at this boundary is therefore facilitated. In leaching by immersion, a further advantage conferred by size reduction is the ease with which finer particles are suspended. Finally, extensive cell rupture occurs during grinding, allowing more direct contact between solvent and solute and more rapid dissolution and diffusion.

Other factors, however, operate against size reduction. Leaching by percolation demands the formation of a permeable bed. Low permeability will give low flow rates and low rates of extraction. Permeability is a complex function of both particle size and porosity, the former determining how a given void space is to be disposed within the bed. The disposition of the void space will consist of few channels of relatively large diameter, that is, a bed of high permeability, if the particle size is large. In leaching by immersion, the difficulties of separating solid and liquid increase as the particle size decreases.

The opposition of the factors suggests an optimum particle size for any particular extraction. This is determined to some extent by the physical nature of the solids. A dense, woody structure would be extracted as a fine powder. An example is given by the root of *Ipecacuanha*. A leafy structure, on the other hand, would be more satisfactorily leached as a coarse powder.

Both porosity and permeability are influenced by the particle size distribution. A high porosity is secured if the distribution is narrow. Small particles may otherwise fill the interstices created by the contact of larger particles. After grinding, therefore, it is often necessary to classify the product and remove undersize material. The undersize would then be bulked with the fines from other batches and separately extracted. A further advantage arising from a narrow size distribution is even packing and the creation of a regular system of pores and waists. This promotes even movement of solvent and solution through the bed.

In some cases, size reduction may take a particular form. Seeds and beans are often rolled or flaked to produce extensive cell rupture. In other processes, the cell wall, although depressing the rate of extraction, may make the extraction more selective by preventing the movement of unwanted materials of high molecular weight. Here the size reduction must leave most cells intact.

### **TEMPERATURE**

Within the limits imposed by the thermal stability of the wanted constituents, a high extraction temperature appears desirable. The solubility of most materials increases as the temperature increases so that higher solute concentrations and

higher concentration gradients are possible. Both this and the increased diffusivity give higher extraction rates. In very many cases, however, materials are susceptible to heat degradation, and cold extraction must be used. In addition, the selectivity of a solvent may be impaired at high temperatures. An example of the use of moderately high temperatures is the extraction of *Rauwolfia* alkaloids with boiling methanol.

### THE PHYSICAL PROPERTIES OF THE SOLVENT

The relevant properties of the solvent are low viscosity and free solution of wanted constituents. These and other aspects of the solvent have already been discussed.

### THE RELATIVE MOVEMENT IMPOSED ON THE SOLIDS AND THE LIQUID

The major and controlling resistance to the diffusion of the solute to the bulk solution is normally found in the cell matrix. Increase in the rate of movement of the solution past the surface will not, therefore, greatly affect the rate of extraction. This is in marked contrast to the processes of dissolution and crystallization. Nevertheless, movement is imposed on the menstruum in both the general methods described earlier.

In the percolation of a liquid through a bed of solids, mass transfer of the solute from the surfaces of the solid to the liquid in the interstices of the bed takes place by molecular diffusion and by natural convection arising from the density changes created by dissolution. Although these processes are slow, they are much quicker than mass transfer in the matrix under the same differences in concentration. Concentration gradients in the liquid outside the particles are, therefore, very low. At any point in the bed, the introduction of dilute solution from above and the loss of concentrated solution to below decrease the interstitial concentration by dilution or displacement. This effect can be considered simply to decrease the solute concentration at the junction of solid and solution, thus imposing a favorable concentration gradient within the matrix.

Similarly, the agitation of the slurry in leaching by immersion is not primarily to decrease the thickness of the boundary layer at the surface and its diffusional resistance. Rather, agitation serves only to keep the particles in suspension and to equalize the solute concentration throughout the liquid. If the particles settle, the solute must diffuse through the stagnant fluid filling the interstices of the bed. High diffusional resistance is created, and the rate of extraction is depressed.

**INTRODUCTION**

In general, crystallinity is the most important underlying property of a solid dictating many of its physicochemical properties including stability. As a unit operation, the term crystallization describes the production of a solid, single-component, crystalline phase from a multicomponent fluid phase (Mullin, 1993). It may be applied to the production of crystalline solids from vapors, melts, or solutions. Crystallization from solution is most important. To complete the preparation of a pure, dry solid, it is also necessary to separate the solid from the fluid phase. This is usually carried out by centrifugation or filtration and by drying. The importance of crystallization lies primarily in the purification achieved during the process and in the physical properties of the product. A crystalline powder is easily handled, is stable, and often possesses good flow properties and an attractive appearance.

Crystallization from a vapor, which occurs naturally, for example, in the formation of hoar frost, is employed in sublimation processes and for the condensation of water vapor during freeze-drying. Equipments may be regarded as specialized condensers in which the principal problems are the removal of the latent heat of crystallization and the discharge of the solid condensate. Condensers are commonly mounted in parallel so that one can be shut down and emptied manually, by conveyor or by melting and draining, without interrupting sublimation. This process is not further considered.

In the pharmaceutical industry, crystallization is usually performed on a small scale from solutions, often in jacketed or agitated vessels. The conditions of crystallization, necessary for suitable purity, yield, and crystal form, are usually established by experiment. Nevertheless, a study of the principal factors that control crystallization is important. In this study, much information is derived from the behavior of carefully prepared melts. These reveal more clearly than solutions the two stages of crystallization: nucleation and crystal growth.

Nucleation describes the formation of small nuclei around which crystals grow. Without the formation of nuclei, crystal growth cannot occur.

**CRYSTALLIZATION IN MELTS**

A melt may be defined as the liquid form of a single material or the homogeneous liquid form of two or more materials that solidifies on cooling. Crystallization in such a system is described by the following sequence: the imposition of supercooling, the formation of nuclei, and the growth of crystals.

If a single-component liquid is cooled, some degree, often large, of supercooling must be established before crystal nuclei are formed and growth begins. A metastable liquid region exists below the melting point, which can only be entered by cooling. In this metastable, supercooled region, the absence of nucleation precludes the formation and growth of crystals. If, however, a crystal seed is added, growth will occur. The deliberate seeding of a metastable system is commonly employed in industrial crystallization. With further cooling, spontaneous nucleation usually takes place and the released heat of

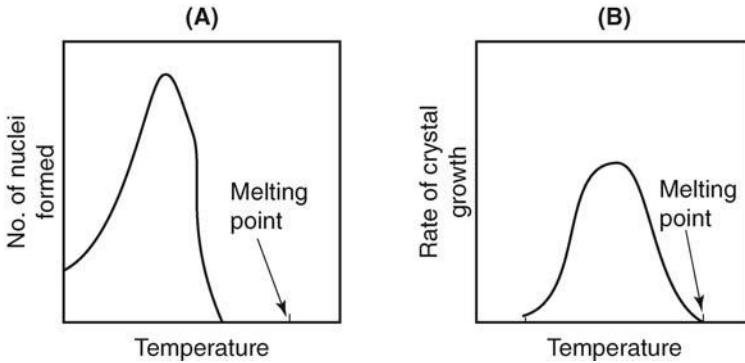

**FIGURE 9.1** (A) Change in nucleation with the degree of supercooling and (B) change in the rate of crystal growth with the degree of supercooling.

crystallization raises the temperature of the melt to its true melting point. With some materials, lower temperatures increase the viscosity and prevent nucleation. The liquid then solidifies into a mass without crystallizing. This is known as vitrification, and the products are called glasses. Many organic materials can be obtained in this form, and, as with glass itself, devitrification may suddenly occur, particularly after heating.

### NUCLEATION

In certain single-component systems, such as piperidine, nucleation and crystal growth are independent and can be separately studied. The rate of nucleation as a function of supercooling is studied by maintaining the melt for a certain time at the given temperature and then quickly raising the temperature to the metastable region where further nucleation is negligible but the already formed nuclei can grow. Figure 9.1A describes the results of such an experiment. At low degrees of supercooling, little or no nucleation takes place. With further cooling, the rate of nucleation rises to a maximum and then falls. The relation, therefore, indicates that excessive cooling may depress the rate of crystallization by limiting the number of nuclei formed.

Spontaneous nucleation is considered to occur when sufficient molecules of low kinetic energy come together in such a way that the attraction between them is sufficient to overcome their momentum. The growth of a nucleus probably takes place over a very short period of time in a region of high local concentration. Once a certain size is reached, the nucleus becomes stable in the prevailing conditions. As the temperature falls, more molecules with low energy are present and the rate of nucleation rises. The decrease in nucleation rate at lower temperature is due to the increase in the viscosity of the melt.

### CRYSTAL GROWTH

If nucleation and crystal growth are independent, the latter can be studied by seeding a melt with small crystals in conditions of little or no natural nucleation. The rate of growth can then be measured. The relation between growth rate and temperature, shown in Figure 9.1B, also exhibits an optimum degree of

supercooling, although the maximum growth temperature is normally higher than the temperature of maximum nucleation. The form of the crystal growth curve is again explained by the kinetics of the molecules. At temperatures just below the melting point, molecules have too much energy to remain in the crystal lattice. As the temperature falls, more molecules are retained and the growth rate increases. Ultimately, however, diffusion to and orientation at the crystal surface are depressed.

For crystal growth in a single-component melt, the molecules at the crystal surface must reach the correct position at the lattice and become suitably orientated, losing kinetic energy. These energy changes appear as heat of crystallization, and this must be transferred from the surface to the bulk of the melt. The rate of crystal growth is influenced by both the rate of heat transfer and the changes taking place at the surface. Agitation of the system will increase heat transfer by reducing the thermal resistance of the liquid layers adjacent to the crystal until the changes at the crystal face become the controlling effect.

In multicomponent melts and solutions, deposition of material at the crystal face depletes the adjacent liquid layers, and a concentration gradient is set up with saturation at the face and supersaturation in the liquid. Diffusion of molecules to the crystal face is discussed in the next section.

The account above describes the behavior of certain carefully prepared melts from which all extraneous matter is rigidly excluded. Dust and other insoluble matter may increase the nucleation rate by acting as centers of crystallization. Soluble impurities may increase or decrease both rates of nucleation and crystal growth. The latter is probably due to adsorption of the impurities on the crystal face. Impurities may also affect the form in which the material crystallizes.

### CRYSTALLIZATION FROM SOLUTIONS

When a material crystallizes from a solution, nucleation and crystal growth occur simultaneously over a wide intermediate temperature range so that a study of these processes is more difficult. In general, however, they are thought to be similar to nucleation and crystal growth in melts. The three basic steps, induction of supersaturation, formation of nuclei, and growth of crystals, are explained with reference to the solubility curve shown in Figure 9.2.

A solution with temperature and concentration indicated by point A may be saturated by either cooling to point B or removing solvent (point C). With

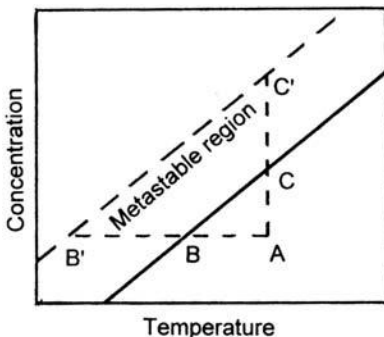
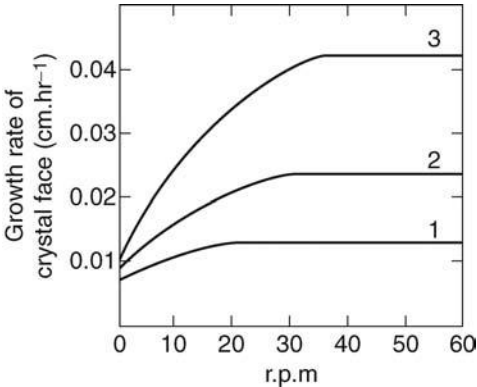

FIGURE 9.2 The solubility-supersolubility diagram.





**FIGURE 9.3** The effect of agitation on the rate of growth of a crystal of sodium thiosulfate.

further cooling or concentration, the supersaturated metastable region is entered. If the degree of supersaturation is small, the spontaneous formation of crystal nuclei is highly improbable. Crystal growth, however, can occur if seeds are added. With greater supersaturation, spontaneous nucleation becomes more probable and the metastable region will be limited approximately by the line B'C'. If the solution is cooled to B' or concentrated by solvent removal to C', spontaneous nucleation is virtually certain. Crystal growth will also occur in these conditions. The rate of growth, however, is depressed at low temperatures.

During crystal growth, deposition on the faces of the crystal causes depletion of molecules in the immediate vicinity. The driving force is provided by the concentration gradient setup, from supersaturation in the solution to lower concentrations at the crystal face. A large degree of supersaturation, therefore, promotes a high growth rate. A reaction at the surface, in which solute molecules become correctly orientated in the crystal lattice, provides a second resistance to the growth of the crystal. Simultaneously, the heat of crystallization must be conducted away.

Agitation modifies the rate of crystal growth for given conditions of temperature and saturation. Initially, agitation quickly increases the rate of growth by decreasing the thickness of the boundary layer and the diffusional resistance. However, as agitation is intensified, a limiting value is reached, which is determined by the kinetics of the surface reaction. In Figure 9.3, the effect of agitation on the rate of crystal growth in solutions of sodium thiosulfate of differing degrees of supersaturation is described.

As with melts, soluble impurities may increase or retard the rate of nucleation. Insoluble materials may act as nuclei and promote crystallization. Impurities may also affect crystal form and, in some cases, are deliberately added to secure a product with good appearance, absence of caking, or suitable flow properties.

The temperature at which crystallization is performed may be determined by the crystal form or degree of hydration required of the products. Reference to the solubility curves given in Figure 9.4 shows that crystallization at 50°C yields  $\text{FeSO}_4 \cdot 7\text{H}_2\text{O}$ , at 60°C yields  $\text{FeSO}_4 \cdot 4\text{H}_2\text{O}$ , and at 70°C,  $\text{FeSO}_4$ . The majority of materials, however, have one or possibly two forms. The degree of supersaturation of solution 1 is 5 g/L, of solution 2 is 10 g/L, and of solution 3 is 15 g/L.

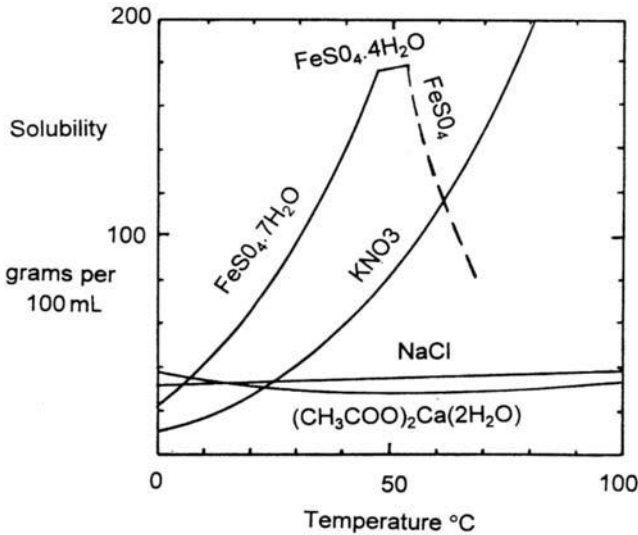

FIGURE 9.4 Solubility curves.

### PRINCIPLES UNDERLYING THE DESIGN AND OPERATION OF CRYSTALLIZERS

The purpose of a crystallization plant is to produce, as far as possible, crystals of the required shape, size distribution, purity, and yield. This is achieved by maintaining a degree of supersaturation at which nucleation and crystal growth proceed at appropriate rates. Control of the number of nuclei formed controls the size of the crystals deposited from a given quantity of solution. Alternatively, crystal number and size can be controlled by adding the correct amount of artificial nuclei or seeds to a system in which little or no natural nucleation is taking place.

In the majority of cases, the mode of operation is determined by the relation between the solubility of the solute and the temperature, examples of which are shown in Figure 9.4. This determines how supersaturation is to be achieved. Other factors of importance are the thermal stability of the solute, the impurities that may be present, and the degree of hydration required. If the solubility of the solute increases greatly with temperature, supersaturation and deposition of a large proportion of the solute are brought about by cooling a hot concentrated solution. Sodium nitrate provides an example. Sodium chloride and calcium acetate, on the other hand, exemplify materials with a small or negative temperature coefficient of solubility. Here, supersaturation can best be achieved by evaporating a part of the solvent. In some cases, both evaporation and cooling are employed. The mother liquors following evaporative crystallization can be cooled to yield a further crop of crystals provided there is a suitable change in solubility and impurities present do not prohibit the process. In other crystallizers, flash cooling is used. A hot solution is passed into a vacuum chamber in which both evaporation and cooling take place.

Supersaturation can also be induced by the addition of a third substance that reduces the solubility of a solute in a solvent. These precipitation processes, which are important in the processing of thermolabile materials, are controlled by the temperature of mixing, the agitation, and the rate at which the third substance is added. Water-insoluble materials dissolved in water-miscible organic solvents can be precipitated by adding water. Alternatively, the aqueous solubility of many materials can be reduced by the change of pH or by the addition of a common ion. Proteins can be salted out of solution by the addition of ammonium chloride and adjustment of pH. Finally, precipitation of a crystalline solid may be the result of a chemical reaction.

A crystallizer should produce crystals of uniform particle size. This facilitates removal of the mother liquor and washing. If large quantities of the liquor are occluded in the mass of crystals, drying will yield an impure product. In addition, crystals of even size are less likely to cake on storage.

### PRODUCTION OF VERY FINE CRYSTALS

Fine powders are important components in pharmaceutical operations. If a substance has a steep solubility curve, fine crystals are produced by quickly cooling the solution through the metastable region to conditions in which the rate of nucleation is high and the rate of crystal growth is low. This method is not always possible, and the precipitation methods described above may be adopted.

### PRODUCTION OF LARGE CRYSTALS

Batch production of large, uniform crystals may be carried out in agitated reaction vessels by slow, controlled or natural cooling. Spontaneous nucleation is improbable until solution A is cooled to X. Crystallization then follows the path XB. Better control is gained if the solution is artificially seeded. Seeding is shown at X'. Crystallization then follows the broken line X'B, the aim being to maintain the solution in the metastable region where growth rate is high and natural nucleation is low. The course of the crystallization is shown in Figure 9.5. Initially, spontaneous nucleation may be allowed by cooling from A to X. As crystallization takes place, the degree of supersaturation and the concentration of the solute fall, ultimately reaching saturation at B when growth will cease. Closer control is secured by artificially seeding the supersaturated solution in

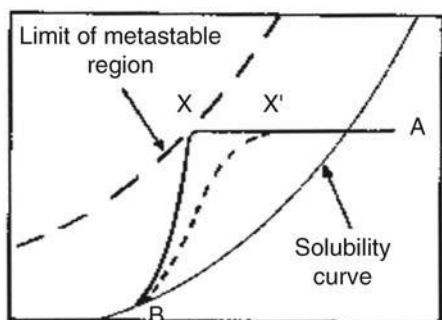

**FIGURE 9.5** The production of large crystals. The conditions of supersaturation.

conditions of no natural nucleation. Seeding is indicated by the point  $X'$ . The course of the crystallization is then indicated by the broken line,  $X'B$ .

An important principle for the continuous production of large even crystals is used in Oslo or Krystal crystallizers. A metastable, supersaturated solution is released into the bottom of a mass of growing crystals on which the solute is deposited. The crystals are fluidized by the circulation of the solution, and classification in this zone allows the withdrawal of sufficiently large crystals from the bottom.

## CRYSTALLIZERS

Although other methods may be adopted, crystallizers can be conveniently classified by the way in which a solution is supersaturated. This leads to the self-explanatory terms: cooling crystallizer and evaporative crystallizer. In vacuum crystallizers, both evaporation and cooling are used.

### Cooling Crystallizers

Open or closed tanks, agitated by stirrers, are used for batch crystallization. The specific heat of the solution and the heat of crystallization are removed by means of jackets or coils through which cooling water can be circulated. Agitation destroys temperature gradients in the tanks, opposes sedimentation and the irregular growth of crystals at the bottom of the vessel, and, as described above, facilitates growth. Similar equipment is used for crystallization or precipitation by the addition of a third substance.

Crystallizers for continuous processes often take the form of a trough cooled naturally or by a jacket. The solution enters at one end, and crystals and liquid are discharged at the other. In one type of crystallizer, a slow-moving worm works in the solution and lifts crystals off the cooling surface to shower them through the solution and slowly convey them through the trough. The trough of another is agitated by rocking. Baffles are used to increase the residence time of the solution. Both crystallizers are characterized by low heat transfer coefficients, and an alternative arrangement consists essentially of a double-pipe heat exchanger. The crystallizing fluid is carried in the central pipe with countercurrent flow of the coolant in the annulus between the pipes. A shaft rotates in the central tube carrying blades, which scrape the heat transfer surface. High heat transfer coefficients are obtained. An Oslo crystallizer, in which supersaturation is given by cooling, is described in Figure 9.6A. The principles underlying this plant have already been described.

### Evaporative Crystallizers

On a small scale, simple pans and stirred reaction vessels can be used for evaporative crystallization. Larger units may employ calandria heating, as shown in Figure 9.6B. The downcomer, which must be large enough to accommodate the flow of the suspension, commonly houses an impeller, forced circulation increasing the heat transfer to the boiling/liquid. These units may be adapted for either batch or continuous processes in which crystal size is not of great importance. For continuous processes demanding close control of product size, an Oslo crystallizer, which saturates the solution by evaporation, may be employed.

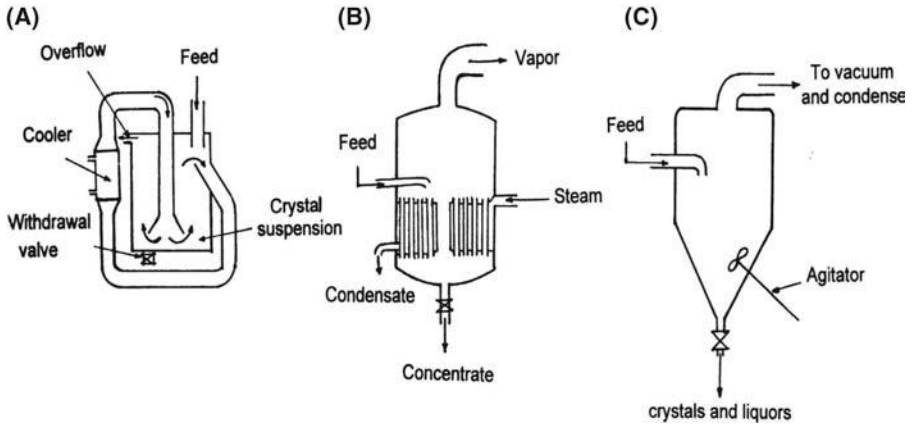

**FIGURE 9.6** (A) Cooling crystallizer, (B) evaporative crystallizer, and (C) batch vacuum crystallizer.

### Vacuum Crystallizers

Vacuum crystallizers produce supersaturated conditions by solvent removal and cooling. An example is shown in Figure 9.6C. A hot, concentrated solution is fed to an agitated crystallization chamber maintained at low pressure. The solution boils and cools adiabatically to the boiling point corresponding to the operating pressure. Crystallization follows concentration, and the product is removed from the bottom of the vessel. The principles of the Oslo crystallizers are also employed in vacuum crystallization.

## EVAPORATION

Evaporation may be defined as the removal of a solvent from a solution by vaporization but is usually restricted to the concentration of solutions by boiling. Crystallization and drying, which may also utilize the vaporization of a liquid, are considered in subsequent sections.

Evaporation in the pharmaceutical industry is primarily associated with the removal by boiling of water and other solvents in batch processes. However, the principles that govern such processes apply more generally and are derived from a study of the transfer of heat to the boiling liquid, the relevant physical properties of the liquid, and the thermal stability of its components.

### Heat Transfer to Boiling Liquids in an Evaporator

The heat required to boil a liquid in an evaporator is usually transferred from a heating fluid, such as steam or hot water, across the wall of a jacket or tube in or around which the liquid boils. A qualitative discussion of the methods used to secure high rates of heat flow can be based on equation (3.9):

$$Q = UA\Delta T$$

where  $Q$  is the rate of heat flow,  $U$  is the overall heat transfer coefficient,  $A$  is the area over which heat is transferred, and  $\Delta T$  is the difference in temperature between the fluids.

The overall heat transfer coefficient is derived from a series of individual coefficients that characterize the thermal barriers that oppose heat transfer. Thus, for the heating fluid, the film coefficient for a condensing vapor, such as steam, is high provided permanent gases and condensate are removed by venting and draining. With liquid heating media, the velocity of flow over the heat transfer surface should be as high as is practicable. If the solid barrier consists of a thin metal wall, the resistance to heat flow will be small. Resistance, however, is significantly increased by chemical scale, which may be deposited on either side. The accumulation of scale should be prevented. A glass wall may provide the largest thermal resistance of the system. Neglecting the thermal stability of the boiling liquid, circulation of the liquid should be rapid and, because of its influence on viscosity, the temperature of boiling should be as high as possible. Both factors promote high film coefficients on the product side of the wall.

Other factors described by the above equation are the area of the heat transfer surfaces, which should be as large as possible, and the temperature difference between the heating surface and the boiling liquid. As long as the critical heat flux is not exceeded, the latter should also be large.

### The Physical Properties of Solution and Liquids

A number of physical factors, which are interrelated in a complex way, are relevant to a study of evaporation. For a given heating fluid, the temperature

difference across the wall of an evaporator is determined by the temperature of boiling, a variable controlled by the external pressure and the concentration of the solute in the solution. Both the boiling temperature and the solute concentration influence the viscosity of the solution, a factor that greatly affects the heat transfer coefficient. The temperature of boiling also determines the solubility of dissolved constituents and the degree of concentration that can be carried out without separation of solids.

#### *The Relation Between Boiling Temperature and Solute Concentration*

When a solute is dissolved in a solvent, the vapor pressure is depressed and the boiling point rises. Since the boiling point increases as the solute concentration increases, the temperature difference between the boiling liquid and the heating surface falls. For dilute solutions, the expected rise in boiling point can be calculated from Raoult's law. However, this procedure is not applicable to concentrated solutions or to solutions of uncertain composition. For aqueous, concentrated solutions, Duhring's rule may be used to obtain the boiling point rise of a solution at any pressure. This rule states that the boiling point of a given solution is a linear function of the boiling point of water at the same pressure. A family of lines is required to cover a range of concentration, as shown in Figure 10.1.

#### *The Relation of Boiling Temperature and External Pressure*

The temperature at which a solution of given composition boils is determined by the external pressure. The vapor pressure of a pure solvent at any temperature can usually be obtained from published tables. Alternatively, if the vapor pressure at two temperatures is known, the plot of the logarithm of the vapor pressure against the reciprocal of the absolute temperature yields an approximately straight line. For intermediate pressures, the temperature at which the solvent will boil can be found by interpolation. If dissolved substances are present, the boiling point must be adjusted using Duhring's rule. This value permits an accurate estimate of the temperature differences in the evaporator.

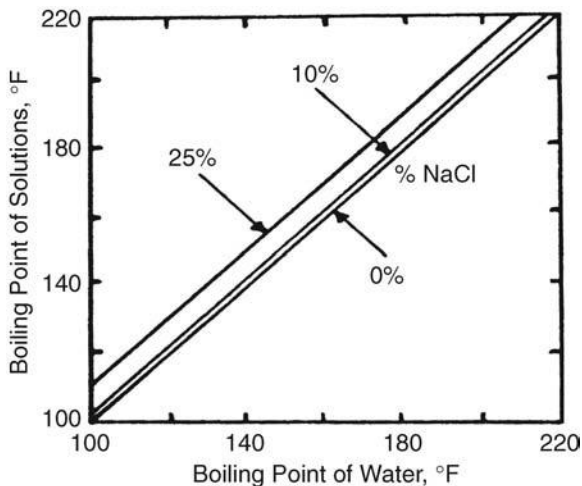

**FIGURE 10.1** Duhring's chart for sodium chloride.

Reduction in the external pressure lowers the boiling temperature and, if the associated increase in viscosity is not too great, increases the rate of evaporation. On large installations, a moderate vacuum is widely used to increase the capacity of an evaporator. The imposition of low pressures and low boiling temperatures is also necessary when thermolabile materials are processed.

Boiling in tubes is commonly used in evaporators. In these circumstances, the hydrostatic head developed by a column of liquid or the friction head imposed by its movement can create a local increase in pressure, which suppresses boiling and decreases the evaporating capacity of the system.

#### *The Relation of Viscosity with Temperature and Solute Concentration*

The viscosity of a solution is modified by changes in temperature and solute concentration. Since a low viscosity promotes a high heat transfer coefficient, the exponential decrease of viscosity with increase in temperature is of great importance and indicates a high boiling temperature.

In general, the addition of a nonvolatile solute increases the viscosity of a solution at any temperature. Consequently, the viscosity of the solution increases as the evaporation proceeds. These effects, however, cannot be calculated.

If at the operating temperatures and concentrations, the viscosity of a solution is high, satisfactory heat transfer coefficients may only be obtained if the liquid is driven over the heating surface. In other systems, movement of a viscous liquid is assisted by gravity or the liquid in contact with the heating surface is disrupted mechanically by scrapers.

#### *The Effect of Temperature on Solubility*

The solubility of the components of a solution depends on the temperature. Most commonly, solubility increases with increase in temperature, so a greater degree of concentration is possible at higher temperatures without the separation of solids. The reverse is true for liquids containing scale-forming solids with inverse solubility characteristics, such as calcium or magnesium sulfate, or materials that decompose and deposit, such as coagulable protein.

#### *The Effect of Heat on the Active Constituents of a Solution*

The thermal stability of components of a solution may determine the type of evaporator to be used and the conditions of its operation. If a simple solution contains a hydrolyzable material and the rate of its degradation during evaporation depends on its concentration at any time, an exponential relation between the remaining fraction,  $F$ , and the time,  $t$ , characteristic of a first-order reaction, is obtained:

$$F = e^{-kt} \quad (10.1)$$

The dependence of the reaction velocity constant,  $k$ , on the absolute temperature,  $T$ , is expressed by the relation

$$k = Ae^{-(B/T)} \quad (10.2)$$

where  $A$  and  $B$  are constants characteristic of the reaction. Thus, at temperatures  $T_1$ ,  $T_2$ , and  $T_3$ , where  $T_1 > T_2 > T_3$ , the relation between remaining fraction and time of heating shown in Figure 10.2 emerges. This indicates the importance of



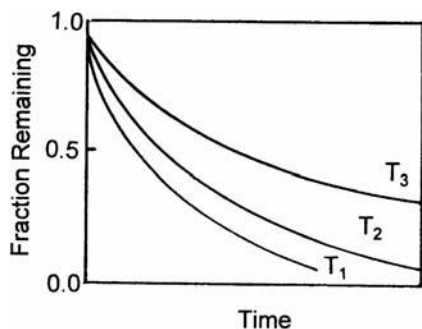

FIGURE 10.2 The effect of time and temperature on degradation.

the temperature and time of heating. If the latter can be shortened, the temperature of evaporation can be greatly increased without increasing the fraction that is degraded. If, therefore, the effect of temperature on the rate of evaporation is known, it is possible to define conditions of time and temperature at which decomposition is a minimum.

In practice, the kinetics of degradation and the relation of evaporation rate and temperature are usually not known. This is particularly true when the criteria by which the product is judged are color, taste, and smell. In addition, the analysis above neglects temperature variation in the evaporating liquid and degradation in boundary films where temperatures are higher. Often, therefore, experiments are necessary to determine the suitability of an evaporation process.

In batch processes, the time of exposure to heat is well defined. This is also true for continuous processes in which the liquid to be evaporated is passed only once through the heater. In continuous processes in which the liquid is recirculated through the heater, the average residence time,  $a$ , is given by the ratio

$$\frac{\text{Working volume of evaporator}}{\text{Volumetric discharge}}$$

in which volumetric discharge is only an indication of the damage that prolonged heating may cause. If perfect mixing occurs in the evaporator, the fraction,  $f$ , which is in the unit for time,  $t$ , or less is given by the equation

$$f = 1 - e^{-(t/a)} \quad (10.3)$$

This relation shows, for example, that an evaporator with an average residence time of one hour holds 13.5% of active principles for two hours and about 2% for four hours.

## EVAPORATORS

It is convenient to classify evaporators into the following: natural circulation evaporators, forced circulation evaporators, and film evaporators.

### Natural Circulation Evaporators

Small-scale evaporators consist of a simple pan heated by jacket, coil, or by both. Admission of the heating fluid to the jacket induces a pool boiling regime in the

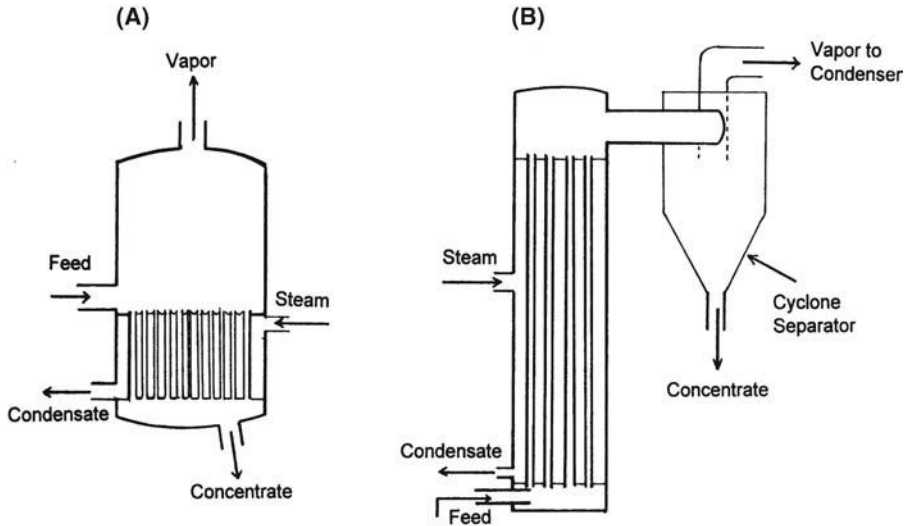

**FIGURE 10.3** (A) Evaporator with calandria and (B) climbing film evaporator.

vessel. Very small evaporators may be open, the vapor escaping to the atmosphere or into a vented hood. Larger pan evaporators are closed, the vapor being led away by pipe. Small jacketed pans are efficient and easy to clean and may be fitted for the vacuum evaporation of thermolabile materials. However, because the ratio of heating area to volume decreases as the capacity increases, their size is limited, and larger vessels must employ a heating coil. This improves evaporating capacity but makes cleaning more difficult.

The large heating area of a tube bundle is utilized widely in large-scale evaporators. Horizontal mounting, with the heating fluid inside the tube, is limited by poor circulation to the evaporation of nonviscous liquids in which the bundle is immersed. Normally, the tube bundle is mounted vertically and is known as a calandria. The boiling of liquids in a vertical tube and the earlier regimes of this process operate in a calandria. The length of tubes and the liquid level are such that boiling occurs in the tubes and the mixture of vapor and liquid rises until the entire calandria is just submerged. A typical evaporator is shown in Figure 10.3A. The tubes are from 1.2 to 1.8 m in length and 5.1 to 7.6 cm in diameter. The low density of the boiling liquid and vapor creates an upward movement in the tubes. Vapor and liquid separate in the space above the calandria, and the liquid is returned to the pool at the base of the tubes by a large central downcomer or through an annular space between the heating element and the evaporator shell. Feed is added and concentrate is withdrawn from the pool, as shown in the figure. As long as the viscosity of the liquid is low, good circulation and high heat transfer coefficients are obtained.

In some evaporators, the calandria is inclined and the tubes are lengthened.

### Forced Circulation Evaporators

On the smallest scale, forced circulation evaporators are similar to the pan evaporators described above, modified only by the inclusion of an agitator.

Vigorous agitation increases the boiling film coefficient, the degree depending on the type and speed of the agitator. An agitator should be used for the evaporation of viscous materials to prevent degradation of material at the heated surfaces.

Some large-scale continuous units are similar to the natural circulation evaporators already described. The natural circulation induced by boiling in a vertical tube may be supplemented by an axial impeller mounted in the downcomer of the calandria. This modification is used when viscous liquids or liquids containing suspended solids are evaporated. Such units are employed in evaporative crystallization. In other forced circulation evaporators, the tube bundle becomes, in effect, a simple heat exchanger through the tubes of which the liquid is pumped. Commonly, the opposing head suppresses boiling in the tubes. Superheating occurs, and the liquid flashes into a mixture of liquid and vapor as it enters the body of the evaporator.

### Film Evaporators

In the short tubes of the calandria, an intimate mixture of vapor and liquid is discharged at the top. If the length of the tube is greatly increased, progressive phase separation occurs until a high-velocity core of vapor is formed, which propels an annular film of liquid along the tube. This phenomenon, which is a stage of flow when a liquid and a gas pass in the same direction along a tube, is employed in film evaporators. The turbulence of the film gives very high heat transfer coefficients, and the bubbles and vapor evolved are rapidly swept into the vapor stream. Although recirculation may be adopted, it is possible, with the high evaporation rates found in long tubes, to concentrate the liquid sufficiently in a single pass. Since a very short residence time is obtained, very thermolabile materials may be concentrated at relatively high temperatures. Film evaporators are also suitable for materials that foam badly. Various types have been developed, but all are essentially continuous in operation, their capacity ranging from a few gallons per hour upward.

The climbing film evaporator, which is the most common film evaporator, consists of tubes 4.6 to 9.1 m in length and 2.5 to 5.1 cm in diameter mounted in a steam chest. This arrangement is described in Figure 10.3B. The feed liquid enters the bottom of the tubes and flows upward for a short distance before boiling begins. The length of this section, which is characterized by low heat transfer coefficients, may be minimized by preheating the feed to its boiling point. The pattern of boiling and phase separation follows, and a mixture of liquid and vapor emerges from the top of the tube to be separated by baffles or by a cyclone separator. Climbing film evaporators are not suitable for the evaporation of viscous liquids.

In the falling film evaporator, the liquid is fed to the top of a number of long heated tubes. Since gravity assists flow down the tube, this arrangement is better suited to the evaporation of moderately viscous liquids. The vapor evolved is usually carried downward, and the mixture of liquid and vapor emerges from the bottom for separation. Even distribution of liquid must be secured during feeding. A tendency to channel in some tubes will lead to drying in others.

The rising-falling film evaporator concentrates a liquid in a climbing film section and then leads the emerging liquid and vapor into a second tube section,

which forms a falling film evaporator. Good distribution in the falling film section is claimed, and the evaporator is particularly suitable for liquids that increase greatly in viscosity during evaporation.

In mechanically aided film evaporators, a thin film of material is maintained on the heat transfer surface irrespective of the viscosity. This is usually achieved by means of a rotor, concentric with the tube, which carries blades that either scrape the tube or ride with low clearance in the film. Mechanical agitation permits the evaporation of materials that are highly viscous or that have a low thermal conductivity. Since temperature variations in the film are reduced and residence times are shortened, the vacuum evaporation of viscous thermolabile materials becomes possible.

### **The Efficiency of Evaporators**

In the pharmaceutical industry, economic use of steam may not be of overriding importance because the small scale of the operation and the high value of the product will not justify the additional capital costs of improved heating efficiency. In other industries, heating costs impose more efficient use of heat. This is secured by utilizing the heat content of the vapor emerging from the evaporator, assumed, until now, to be lost in a following condensation. Two methods commonly used are multiple effect evaporation and vapor recompression.

In multiple effect evaporation, the vapor from one evaporator is led as the heating medium to the calandria of a second evaporator, which, therefore, must operate at a lower temperature than the first. This principle can be extended to a number of evaporators, some stages working under vacuum. The limit is set by the relation of the cost of the plant and the vacuum services with the cost of the steam that is saved.

In evaporators employing vapor recompression, the vapor emerging is compressed by mechanical pumps or steam jet ejectors to increase its temperature. The compressed vapor is returned to the steam chest.

### **Vapor Removal and Liquid Entrainment**

Vapor must be removed from the evaporator with as little entrained liquid as possible. The two determining factors are the vapor velocity at the surface of the liquid and the velocity of the vapor leaving the evaporator. On a small scale, surface vapor velocities will be low, but with increase in scale, the adverse ratio of surface area to volume creates higher velocities. Droplets formed by the bursting of bubbles at the boiling surface may then be projected from the surface. In addition, foam may form. Various devices may be used to control entrainment at or near the surface. A high vapor space is provided above the boiling liquid to allow large droplets to fall and foam to collapse. Baffles may be used in the vapor space to arrest entrained droplets. Where allowable, antifoaming agents, such as silicone oils, can be used to depress foaming.

Stokes' law shows that vapor of particular characteristics will carry droplets upward against the force of gravity. Any entrained liquid not intercepted in the body of the evaporator will, therefore, be carried forward in the higher-velocity stream of the vapor uptake. Some droplets will be caught here, the quantity depending on the geometry of the duct and the velocity of the vapor. At atmospheric pressure, the latter might be 17 m/sec. In vacuum

evaporation, much higher velocities may be used. When the quantity of entrained liquid is high, the vapor is commonly led to a cyclone separator. This is employed with frothing materials and the vapor-liquid mixture leaving a climbing film evaporator. In the separator, the entrained liquid is flung out to the walls by centrifugal force and may be collected or returned to the evaporator. The vapor is led to a condenser.

### Evaporation without Boiling

During heating, some evaporation takes place at the surface of a batch of liquid before boiling begins. Similarly, liquids that are very viscous or that froth excessively may be concentrated without boiling. The diffusion of vapor from the surface is then described by equation (4.5) as:

$$N_A = \frac{k_g}{RT}(P_{Ai} - P_{Ag})$$

where  $N_A$  is the number of moles evaporating from unit area in unit time,  $k_g$  is the mass transfer coefficient across the boundary layer,  $R$  is the gas constant,  $T$  is the absolute temperature,  $P_{Ai}$  is the vapor pressure of the liquid, and  $P_{Ag}$  is the partial pressure of the vapor in the gas stream.  $k_g$  is proportional to the gas velocity.

## DISTILLATION

Distillation is a process in which a liquid mixture is separated into its component parts by vaporization. The vapor evolved from a boiling liquid mixture is normally richer in the more volatile components than the liquid with which it is in equilibrium. Distillation rests on this fact. Although multicomponent mixtures are most common in distillation processes, an understanding of the operation can be based on the vapor pressure characteristics of two-component or binary mixtures. Binary systems in which the liquids are immiscible are discussed first. Discussion of the separation of miscible liquids by fractionation forms most of the remainder of the section.

### Binary Mixtures of Immiscible Liquids: Steam Distillation

If the two components of a binary mixture are immiscible, the vapor pressure of the mixture is the sum of the vapor pressures of the two components, each exerted independently and not as a function of their relative concentrations in the liquid. This property is employed in steam distillation, a process particularly applicable to the separation of high-boiling point substances from nonvolatile impurities. The steam forms a cheap and inert carrier. The principles of the process, however, apply to other immiscible systems.

If a mixture of water and a high-boiling point liquid, such as nitrobenzene, is heated, the total vapor pressure increases and ultimately reaches the external pressure. The mixture boils, and the vapors evolved are condensed to give a liquid mixture, which separates under gravity. In practice, the vapors are produced by blowing steam into the liquid in a manner that gives intimate contact between the phases. Since both components contribute to the total pressure, the boiling temperature must be lower than the boiling point of either component. In the case of nitrobenzene and water, the boiling point at atmospheric pressure

is about 372 K. To distill nitrobenzene alone at this temperature, a pressure of 20 mmHg must be imposed. Steam distillation, therefore, permits the distillation of water-immiscible materials of high boiling point without the use of high temperatures, which might cause decomposition, or high vacua. The method, however, will only separate such materials from nonvolatile constituents. If volatile impurities are present, these will appear in the distillate.

The composition of the distillate is calculated in the following way. For two components, A and B, the total vapor pressure,  $P$ , is the sum of the vapor pressures of the components,  $P_A$  and  $P_B$ . Since the partial pressure of a component in a gaseous mixture is proportional to its molar concentration, the composition of the vapor is given by

$$\frac{n_A}{n_B} = \frac{P_A}{P_B} \quad (10.4)$$

where  $n_A$  and  $n_B$  are the number of moles of A and B in the vapor, respectively. If  $W_A$  and  $W_B$  are the weights of A and B in the vapor, then

$$\frac{W_A}{M_A} \cdot \frac{M_B}{W_B} = \frac{P_A}{P_B} \quad (10.5)$$

where  $M_A$  and  $M_B$  are the respective molecular weights. The distillate obtained from the vapor is  $W_A + W_B$ . Therefore,

$$\text{Percentage of A in the distillate} = \frac{W_A}{W_A + W_B} \times 100 = \frac{P_A M_A}{P_A M_A + P_B M_B} \times 100 \quad (10.6)$$

The ratio of immiscible organic liquid to water in the distillate is increased if the former has a high molecular weight or a high vapor pressure.

Steam distillation under vacuum may be employed when the thermal stability of the material prohibits temperatures of about 373 K. A further variant is the introduction of unsaturated steam under conditions in which no condensation to water takes place. Only two phases, the liquid being distilled and the mixed vapors, are then present. The external pressure no longer fixes the temperature, as in a three-phase system, and any convenient value can be chosen.

The chief uses of steam distillation are the purification and isolation of liquids of high boiling point, such as aniline, nitrobenzene, or  $\sigma$ -dichlorobenzene, and the preparation of fatty acids and volatile oils. Many of the latter are prepared by introducing steam into a mixture of the comminuted drug and water. The method is also used to remove odoriferous elements, such as aldehydes and ketones, from edible oils. The dehydration of a material by adding a volatile, water-immiscible solvent, such as toluene, and distilling the mixture is a form of steam distillation. The solvent separates in the condensate and may be returned to the still.

## Binary Mixtures of Miscible Liquids

### *The Relation of Vapor Pressure and Mixture Composition*

When the two components of a binary mixture are completely miscible, the vapor pressure of a mixture is a function of mixture composition as well as the vapor pressures of the two pure components. If the liquids are ideal, the relation of vapor pressure and composition is given by Raoult's law. At a

constant temperature, the partial vapor pressure of a constituent of an ideal mixture is proportional to its mole fraction in the liquid. Thus, for a mixture of A and B,

$$P_A = P_A^\circ X_A \quad (10.7)$$

where  $P_A$  is the partial vapor pressure of A in the mixture,  $P_A^\circ$  is the vapor pressure of pure A, and  $x_A$  is its mole fraction. Similarly,

$$P_B = P_B^\circ X_B \quad (10.8)$$

The total pressure of the system,  $P$ , is simply  $P_A + P_B$ .

These relations can be expressed graphically. If the vapor pressure at a given temperature of each pure component is marked on a graph of vapor pressure versus mole fraction, the total vapor pressure at the same temperature of a liquid mixture of any composition falls on the straight line joining the vapor pressures of the two components. The partial pressure of each component is indicated by the diagonals of this figure. The principle is shown in Figure 10.4. A separate relation must be constructed for each temperature.

Very few liquid mixtures rigidly obey Raoult's law. Consequently, the vapor pressure data must be determined experimentally. Mixtures that deviate positively from the law give a total vapor pressure curve that lies above the theoretical straight line. Negative deviations fall below the line. In extreme cases, deviations are so large that a range of mixtures will exhibit a higher or lower vapor pressure than that of either of the pure components.

Returning to ideal systems, the partial pressure of a component in the vapor is proportional to its mole fraction. For component A,

$$P_A = y_A P \quad (10.9)$$

where  $P_A$  is the partial pressure of A in the vapor and  $y_A$  is its mole fraction.

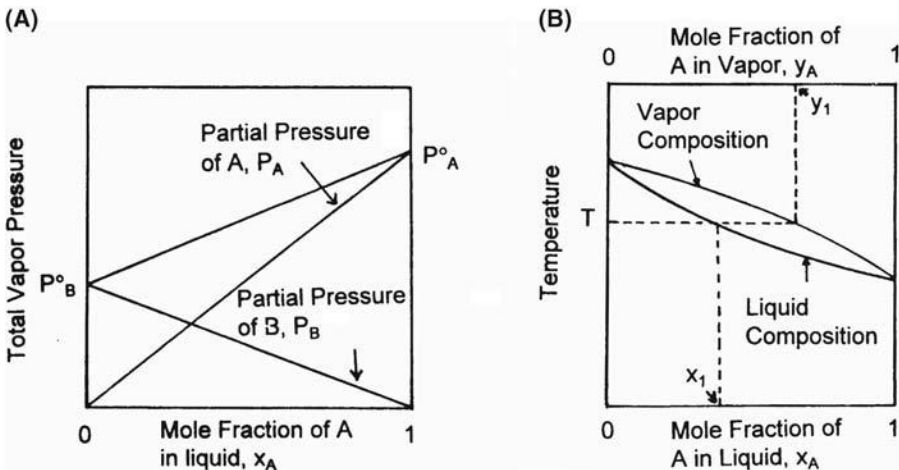

FIGURE 10.4 (A) The vapor pressure of an ideal binary mixture. (B) Phase diagram.

Since  $P_A = P_A^\circ \cdot x_A$ ,

$$y_A = \frac{x_A P_A^\circ}{P} \quad (10.10)$$

Similarly,

$$y_B = \frac{x_B P_B^\circ}{P} \quad (10.11)$$

If A is the more volatile component,  $P_A^\circ$  is greater than  $P \cdot y_A$  is therefore greater than  $x_A$ , that is, the vapor is richer in the more volatile component than the liquid with which it is in equilibrium.

### The Relation of Boiling Point and Mixture Composition

For the purposes of distillation, curves relating vapor pressure and composition are usually replaced by boiling point curves. These are determined by experiment at the given pressure. Figure 10.5A represents a system in which the vapor pressure of some mixtures is greater than the vapor pressure of the pure, more volatile component. This system will exhibit a minimum boiling point, and the composition of the liquid at this point is given by Z. This mixture, which is a constant-boiling or azeotropic mixture, evolves on boiling a vapor of the same composition. In the binary system described in Figure 10.5B, mixtures are formed with a vapor pressure that is less than that of the less volatile component. The maximum boiling point is given by the azeotropic mixture, Z.

Systems that form minimum-boiling mixtures are common. Ethyl alcohol and water provide an example, the azeotrope containing 4.5% by weight of water. The boiling point at atmospheric pressure is 351.15 K, 0.25 K lower than the boiling point of pure alcohol. Maximum-boiling mixtures are less common. The most familiar example is hydrochloric acid, which forms an azeotrope boiling at 381 K and contains 20.2% by weight of hydrochloric acid.

Mixtures that form azeotropes cannot be separated into the pure components by normal distillation methods. However, separation into the azeotrope and one pure component is possible. Efficient fractionation of the mixture M of Figure 10.5A would give the azeotrope Z as distillate and pure B as the residue.

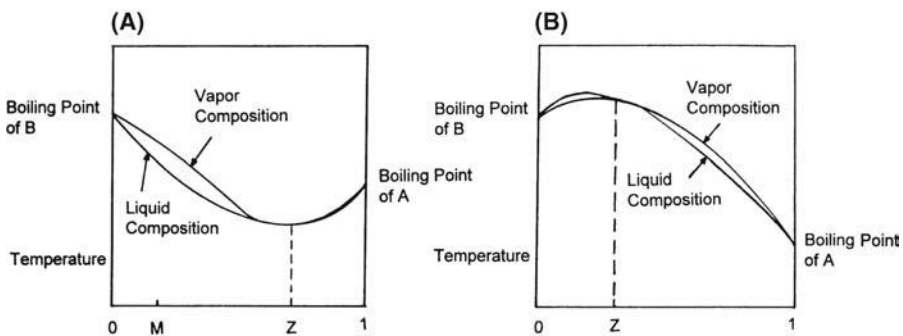

**FIGURE 10.5** Temperature-composition diagrams for a binary mixture. (A) Minimum azeotrope and (B) maximum azeotrope.



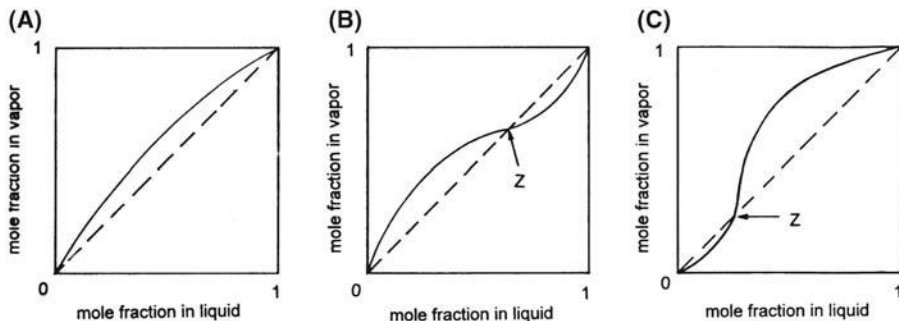

FIGURE 10.6 Vapor-liquid equilibrium diagrams.

The composition of the azeotropic mixture of a system is a function of the total pressure, and it is possible, in some cases, to eliminate the constant-boiling mixture by altering the pressure at which the distillation is performed. For example, at pressures less than 100 mmHg, ethyl alcohol and water do not form an azeotrope. At this pressure, they can be completely separated.

### Vapor-Liquid Equilibrium Diagrams

Vapor-liquid equilibrium diagrams of the form shown in Figure 10.6 provide an alternative and convenient method of recording distillation data. They consist of a conventional graph relating the mole fraction of the more volatile component in the liquid, designated  $X$ , to the mole fraction of the more volatile component in the vapor, designated  $Y$ . An ideal binary system is shown in Figure 10.6A. The temperature varies along each of the curves, and the diagram is only applicable to the pressure at which the variables were measured. Curves of minimum-boiling mixtures and maximum-boiling mixtures are drawn in Figure 10.6B and C, respectively.

### Simple or Differential Distillation

In simple or differential distillation, the vapor evolved from the boiling mixture is immediately removed and condensed. For the system shown in Figure 10.7A, the liquid of composition  $x_1$  evolves a vapor of composition  $y_1$ . Its removal impoverishes the liquid in the more volatile component. The composition of the liquid moves toward pure B, and its boiling point increases. There is, therefore, a progressive change in the composition of the vapor, the mole fraction of the more volatile component steadily decreasing. Unless the boiling points of the two pure components differ widely, a reasonable degree of separation is not possible. The method may be used to remove low-boiling point solvents from aqueous solutions.

### Rectification or Fractionation

In simple distillation, vapor enrichment is small. In fractionation, a term synonymous with rectification, the vapor leaving the boiling liquid is led up a column to meet a liquid stream or reflux, which originates higher in the column

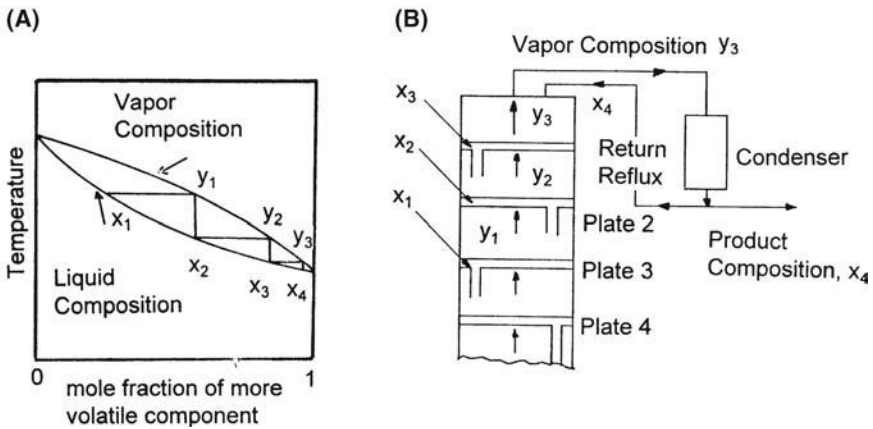

**FIGURE 10.7** (A) Three ideal stages in a fractional distillation and (B) the plate column associated with the fractional distillation.

as part of the condensate. In a series of partial condensations and vaporizations, the rising vapor becomes richer in the more volatile component at the expense of the falling liquid and high degrees of separation become possible. The columns, which are called fractionating columns, are of two basic types: packed columns and plate columns.

Packed columns are used for laboratory and small-scale industrial distillation and are usually operated as a batch process. The column consists of a vertical, hollow, cylindrical shell containing a packing designed to offer a large interfacial contact area between liquid and vapor. The form of the packing varies, but Raschig rings, which consist of small metallic or ceramic cylinders, are the most commonly used. Other shapes consist of saddles, Pall rings, Lessing rings, and meshes of either woven wire or expanded metal. In a packed column, countercurrent interaction between the rising vapor and the falling liquid occurs throughout its length. The distillation rate and the size and shape of the packing must be chosen to give efficient support for the liquid phase, phase movement, and phase interaction. High rates of vapor flow may arrest or reverse the downward movement of liquid. This ultimately causes flooding of the column and determines the upper end of the operating range. The efficiency of the column is also decreased if the falling liquid fails to wet all the available surface of the packing, a condition that determines the lower limit of column operation. In general, packed columns operate under widely varying conditions without serious loss of efficiency.

### *Plate Columns*

A plate column consists of a series of plates or trays on which the liquid is retained for some period during its movement down the column. The rising vapor is bubbled through this liquid, providing intimate contact between the phases. Liquid in reflux moves downward between plates and is usually carried by a downcomer. Contact between the vapor and liquid takes place in stages.

Plate columns operate efficiently over a limited range of conditions. They are mainly used in large-scale, continuous installations in which the conditions of distillation can be closely maintained.

#### *The Principles of Continuous and Batch Fractionation*

Figure 10.7A is the boiling point curve of a binary mixture. If a mixture of composition  $x_1$  is boiled, a vapor of composition  $y_1$  is evolved, and condensation gives a liquid of composition  $x_2$ . This is an ideal distillation stage. A second stage gives a liquid of composition  $x_3$ , and in this example, a further stage would give the more volatile component in an almost pure form.

These conditions are approached in continuously operated fractionating columns. In such a column, operating with continuous feed and product withdrawal, the composition of the liquid and vapor at any point does not vary with time. The process is examined with reference to the plate column shown in Figure 10.7B. Let the composition of the liquid on plate 3 be  $x_1$ . The vapor received at this plate from the plate below is bubbled through the liquid on the plate. Some of the less volatile component is condensed, increasing the mole fraction of the more volatile component in the bubbles. The latent heat evolved by this condensation vaporizes some of the liquid on the plate. This vapor is richer in the more volatile component than the liquid. By these two mechanisms, the vapor that will leave the plate moves toward equilibrium, with the liquid on the plate. If equilibrium could be achieved, maximum enrichment of the vapor would occur corresponding to the appropriate horizontal line linking vapor-liquid equilibrium concentrations on the boiling point curve. For the system shown in Figure 10.7B, this is the line  $x_1x_1$ . Two more ideal distillation stages at plates 2 and 1 would complete the separation of this mixture. In practice, equilibrium is not achieved at the plates because of limited contact between the phases. Enrichment is therefore less than that at an ideal stage, and the discrepancy is a measure of plate efficiency.

Under steady-column conditions, the concentration of the more volatile component in the liquid on any plate is maintained by the overflow or reflux of liquid richer in the more volatile component from the plate above. This is true for all parts except the top plate. Here, the mole fraction of the more volatile component must be maintained by returning part of the condensate from the last stage to the top plate. This is known as reflux return, and the reflux ratio is the ratio of the condensate returned to the column and the amount withdrawn as product. This ratio markedly affects the degree of separation that occurs in a given column. If the proportion of the condensate that is to be returned to the column is increased, the mole fraction of the more volatile component in the liquid on the top plate is increased. The mole fraction of this component in the emerging vapor is also increased and a purer product is obtained. By the increased overflow of liquid from plate to plate down the column, this will also be true for all plates. Thus, by increasing the reflux ratio, the enrichment obtained with a given number of plates is increased. The amount of product, however, is decreased. A column operating at total reflux, in which the whole of the distillate is returned to the column, achieves a given enrichment with the minimum number of plates. This column, however, gives no product at all, and an economic compromise is sought between a short column with a small number of plates operating with high reflux ratio and a long column of many plates operating with a low reflux ratio.

Algebraic and graphical methods are used to calculate the theoretical number of plates required to separate a mixture in a column operating with a known reflux ratio.

In a packed column, enrichment of the vapor takes place continuously as the column is ascended. The enrichment taking place over a certain length of the column will correspond to the enrichment secured at a plate that behaves ideally. This is expressed as the height equivalent of a theoretical or ideal plate (HETP). This concept allows the account given for plate columns to be directly applied to packed columns. The height of packing required for a separation is simply the product of the HETP and the number of ideal stages required. The HETP is not constant for a given packing. It depends on the physical properties of the liquid and the vapor, such as density and viscosity, and on the distillation rate.

In batch distillation, steady-state conditions are never achieved and the concentration of the more volatile component in the still or at any point in the column falls as the rich product is withdrawn from the top. The concentration of the more volatile component in the product also falls. To maintain a given product specification, it may be necessary to increase the reflux ratio from time to time. Alternatively, the reflux ratio could be so chosen that the average composition of the product complies with the specification, the first distillate being enriched and the last, depleted of the more volatile component.

Most distillations, whether operated as batch or continuous processes, are applied to mixtures of more than two components. If the boiling points of the components differ widely, the process may be treated as successive distillation of two component mixtures. If a mixture of three components, A, B, and C, is batch distilled, a column with sufficient plates will initially separate the most volatile component, A, with a high purity. As the distillation progresses, the concentration of A in the distillate falls, and ultimately, the column fails to produce a distillate of the required quality. An intermediate fraction is then distilled, consisting of A and B, until the distillate contains the required amount of B. After collection of this fraction, a second intermediate fraction is distilled to leave component C in the still. Intermediate fractions can be distilled with subsequent batches. A similar separation could be accomplished with two continuous columns, one separating A from B and C and another separating B from C.

To avoid thermal decomposition of a component in a mixture, distillation may be performed at a reduced pressure. In addition to the general principles described above, the following factors may be of importance. First, the pressure drop associated with the flow of vapor up the column, which is relatively small in atmospheric distillation, may become significant, producing a damaging increase in the temperature of the liquid in the still. Second, in packed columns, flooding occurs at lower distillation rates because of the high velocity of the rising vapor.

### **Separation of Azeotropes and Liquids of Similar Volatility**

Systems that form azeotropes cannot be separated by fractional distillation, although in some cases, the formation of the azeotrope can be precluded by changing the distillation pressure. Problems of separation are also found with mixtures of liquids with similar volatility. Separation of these systems can be

facilitated by adding a third component. If this component forms one or more azeotropes with the original components of the mixture, the process is called azeotropic distillation. The addition of a relatively nonvolatile component, which alters the relative volatility of the original components, gives a process known as extractive distillation.

In the azeotropic distillation of minimum-boiling binary mixtures, the third component forms either a new binary azeotrope of lower boiling point or a ternary azeotrope of lower boiling point containing the original components in different proportions. The newly formed azeotrope must be easily separated after distillation. The process is illustrated by the dehydration of alcohol with benzene. The binary azeotrope of ethyl alcohol and water boils at 351.15 K, the ternary azeotrope of benzene, water, and alcohol boils at 337.8 K, and the binary azeotrope of benzene and alcohol boils at 341 K. Distillation of the alcohol-water azeotrope with benzene yields the ternary azeotrope that separates on condensation to give two layers, one of which contains almost all the water. In a batch process, the column would then give the benzene alcohol azeotrope, leaving anhydrous alcohol in the still. In a continuous process, the various stages would each be performed on a different column.

Extractive distillation is illustrated by the separation of benzene and cyclohexane by adding phenol. The relative volatility of the original components is modified so that cyclohexane is recovered as the distillate, leaving a mixture of phenol and benzene, which is passed to a second column for separation. The phenol, which is added to the top of the column, appears to aid separation by preferentially dissolving benzene during its passage downward. This leads to the term extractive distillation.

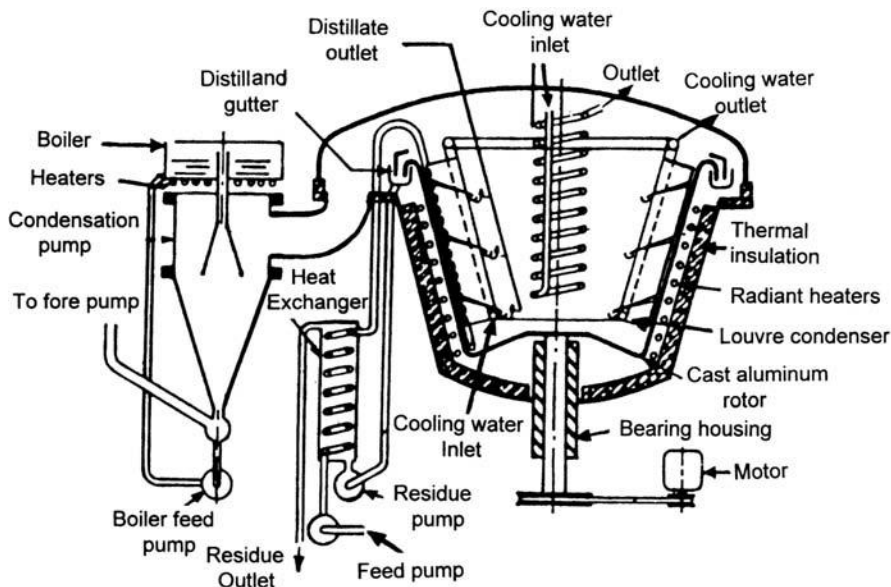

FIGURE 10.8 Large-scale molecular still.

**Molecular Distillation**

Molecular distillation is carried out without boiling at very low pressures of the order 0.001 mmHg. At these pressures, collision of molecules in the evolving vapor and reflection back to the liquid surface are greatly decreased and the mean free path of the molecules is of the same order as the distance between the evaporating surface and a condenser placed a short distance away. It then becomes possible to distill liquids of very high boiling point, although the degree of separation cannot exceed one theoretical plate. The process is therefore used primarily to concentrate nonvolatile components in a high-boiling point medium. The vitamins in cod liver oil can be concentrated in this way. For the separation of liquids of comparable volatility, several separate distillation stages will be necessary.

Since agitation due to boiling is absent, an alternative method of maintaining the more volatile component at the evaporating surface must be adopted. In the industrial molecular still shown in Figure 10.8, the feed is introduced at the bottom of a heated conical rotor and flows upward as a thin liquid layer under the action of centrifugal force. The residue is caught in a gutter at the top. The vapor is condensed on a concentric, water-cooled condenser a short distance away and discharged.

## INTRODUCTION

A student of pharmacy will have used filtration extensively in the collection of precipitates in chemical analyses or in the preparation of parenteral fluids and will, therefore, anticipate the definition of filtration as the removal of solids suspended in a liquid or gas by passage through a pervious medium on which the solids are retained. The pervious medium or septum is normally supported on a base, and these, together with a suitable housing providing free access of fluid to and from the septum, comprise the filter.

The applications of filtration are diverse. They may, however, be classified as either clarification or cake filtration.

### Clarification

Very high standards of clarity are imposed during the production of pharmaceutical solutions. The aim may be simply the presentation of an elegant product, although complete freedom from particulate matter is obviously necessary in the manufacture of most parenteral solutions. The solids are unwanted and are normally present in a very small concentration. Clarification may be carried out by the use of thick media, which allow for the penetration and arrest of particles by entrapment, impingement, and electrostatic effects. This leads to the concept of depth filtration in which particles, perhaps a hundred times smaller than the dimensions of the passages through the medium, are removed. For this reason, such filters are not absolute and must be designed with sufficient depth so that the probability of the passage of the smallest particle under consideration through the filter is extremely small.

Depth filtration differs fundamentally from the use of media in which pore size determines the size of particle retained. Such filters may be said to be "absolute" at a particle diameter closely related to the size of the pore, so that there is a relatively sharp division between particles that pass the filter and those that are retained. An analogy with sieving may be drawn for this mechanism. The life of such filters depends on the number of pores available for the passage of fluid. Once a particle is trapped at the entrance to the pore, the pore's contribution to the overall flow of liquid is very much reduced. Coarse straining with a wire mesh and the membrane filter employ this mechanism.

Sterilization of liquids by filtration could be regarded as an extreme application of clarification in which the complete removal of particles as small as  $0.3 \times 10^{-6}$  m must be ensured.

### Cake Filtration

The most common industrial application is the filtration of slurries containing a relatively large amount of suspended solids, usually in the region of 3% to 20%. The septum acts only as a support in this operation. The actual filtration is carried out by the solids deposited as a cake. In such cases, solids may

completely penetrate the septum until the deposition of an effective cake occurs. Until this time, cloudy filtrate may be recycled. The physical properties of the cake largely determine the methods employed. Often, washing and partial drying or dewatering are integral parts of the process. Effective discharge of the cake completes the process. The solids, the filtrate, or both may be wanted.

### THE THEORIES OF FILTRATION

Two aspects of filtration theory must be considered. The first describes the flow of fluids through porous media. It is applicable to both clarification and cake filtration. The second, which is of primary importance only in clarification, examines the retention of particles in a depth filter.

#### Flow of Fluids Through Porous Media

The concept of a channel with a hydraulic diameter equivalent to the complex interstitial network that exists in a powder bed leads to the equation

$$\frac{Q}{\eta L} = K A \Delta P \quad (11.1)$$

where  $Q$  is the volumetric flow rate,  $A$  the area of the bed,  $L$  the thickness of the bed,  $\Delta P$  the pressure difference across the bed, and  $\eta$  the viscosity of the fluid. The permeability coefficient,  $K$ , is given by  $\varepsilon^3/5(1 - \varepsilon)^2 S_0^2$  where  $\varepsilon$  is the porosity of the bed and  $S_0$  is its specific surface area ( $\text{m}^2/\text{m}^3$ ).

#### Factors Affecting the Rate of Filtration

Equation (1) may be used as a basis for the discussion of the factors that determine the rate of filtration.

##### *Pressure*

The rate of filtration at any instant of time is directly proportional to the pressure difference across the bed.

In cake filtration, deposition of solids over a finite period increases the bed depth. If, therefore, the pressure remains constant, the rate of filtration will fall. Alternatively, the pressure can be progressively increased to maintain the filtration rate.

Conditions in which the pressure is substantially constant are found in vacuum filtration. In pressure filtration, it is usual to employ a low constant pressure in the early stages of filtration for reasons given below. The pressure is then stepped up as the operation proceeds.

This analysis neglects the additional resistance derived from the supporting septum and the thin layer of particles associated with it. At the beginning of the operation, some particles penetrate the septum and are retained in the capillaries in the manner of depth filtration, while other particles bridge the pores at the surface to begin the formation of the cake. The effect of penetration, which is analogous to the blinding of a sieve, is to confer a resistance on the cake-septum junction, which is much higher than the resistance of the clean septum with a small associated layer of cake. This layer may contribute heavily to the total resistance. Since penetration is not reversible, the initial period of cake filtration is highly critical and is usually carried out at a low pressure. The



amount of penetration depends on the structure of the septum, the size and shape of the solid particles, their concentration, and the filtration rate.

When clarifying at constant pressure, a slow decrease in filtration rate occurs because material is deposited within the bed.

### *Viscosity*

The inverse relation between flow rate and viscosity indicates that, as expected, higher pressures are required to maintain a given flow rate for thick liquids than that necessary for filtering thin liquids. The decrease in viscosity with increase in temperature may suggest the use of hot filtration. Some plants, for example, the filter press, can be equipped so that the temperature of hot slurries can be maintained.

### *Filter Area*

In cake filtration, a suitable filter area must be employed for a particular slurry. If this area is too small, the excessively thick cakes produced necessitate high pressure differentials to maintain a reasonable flow rate. This is of great importance in the filtration of slurries giving compressible cakes. When clarifying, the relation is simpler. The filtration rate can be doubled by simply doubling the area of the filter.

### *Permeability Coefficient*

The permeability coefficient may be examined in terms of its two variables, porosity and surface area.

Evaluation of the term  $\epsilon^3/(1-\epsilon)^2$  shows that the permeability coefficient is a sensitive function of porosity. When filtering a slurry, the porosity of the cake depends on the way in which particles are deposited and packed. A porosity or void fraction ranging from 0.27 to 0.47 is possible in the regular arrangements of spheres of equal size. Intermediate values will normally be obtained in the random deposition of deflocculated particles of fairly regular shape. A fast rate of deposition, given by concentrated slurries or high flow rates, may give a higher porosity because of the greater possibility of bridging and arching in the cake. Although theoretically the particle size has no effect on porosity (assuming that the bed is large compared with the particles), a broad particle size distribution may lead to a reduction of porosity if small particles pack in the interstices created by larger particles.

Surface area, unlike porosity, is markedly affected by particle size and is inversely proportional to the particle diameter. Hence, as commonly observed in the laboratory, a coarse precipitate is easier to filter than a fine precipitate even though both may pack with the same porosity. Where possible, a previous operation may be modified to facilitate filtration. For example, a suitable particle size may be obtained in a crystallization process by control of nucleation or the proportion of fines in milling may be reduced by carefully controlling residence times. In the majority of cases, however, control of this type is not possible, and with materials that filter only with difficulty, much may be gained by conditioning the slurry, an operation that modifies both the porosity and the specific surface of the depositing cake.

In clarification, high permeability and filtration rate oppose good particle retention. In the formation of clarifying media from sintered or loose particles, accurate control of particle size, specific surface, and porosity is possible so that a medium that offers the best compromise between permeability and particle retention can be designed. The analysis of permeability given above can be accurately applied to these systems. Because of the extremes of shape, this is not so for the fibrous media used for clarification. Here it is possible to develop a material of high permeability and high retentive capacity. However, such a material is intrinsically weak and must be adequately supported.

### The Retention of Particles in a Depth Filter

Theoretical studies of particle retention have been restricted to granular media of a type used in the purification of municipal water. The aim is to predict the variation of filtrate quality with influent quality or time and then estimate the effect of removed solids on the permeability of the bed. Such studies have some bearing on the use of granular, sintered, or fibrous beds used for clarifying pharmaceuticals.

The path followed by the liquid through a bed is extremely tortuous. Violent changes of direction and velocity will occur as the system of pores and waists is traversed. Deflection of particles by gravity or, in the case of very fine particles, by Brownian movement will bring particles within range of the attractive forces between particles and the medium and cause arrest. Inertial effects, that is, the movement of a particle across streamlines by virtue of its momentum, are considered to be of importance only in the removal of particles from gases. In liquid-solid systems, density differences are much smaller.

Opportunity for contact and arrest depends on the surface area of the bed, the tortuosity of the void space, and the interstitial speed of the liquid. Since the inertial mechanism is ineffective, increase in interstitial velocity decreases the opportunity for contact and retention of particles by the medium. Therefore, the efficiency of a filter decreases as the flow rate increases. However, efficiency increases as the density or size of the influent particles increases and decreases as the particle size in the bed decreases. Each layer of clean filter is considered to remove the same proportion of the particles in the influent. Mathematically expressed,

$$\frac{dC}{dx} = -KC \quad (11.2)$$

where  $C$  is the concentration of the particles that enter an element of depth  $dx$ . The value of  $K$ , which is a clarifying coefficient expressing the fraction of particles that deposit in unit depth of the bed, changes with time. Initially, the rate of removal increases and the efficiency of filtration improves. It has been suggested that this is because the deposition of particles in the bed is at first localized and the surface area and tortuosity increase. Later, the efficiency of removal decreases because deposition narrows the pores, reduces convolutions and surface area, and increases the interstitial liquid velocity. The failure of the medium to adequately retain particles or the decrease in permeability and filtration rate eventually limits the life of the filter. If deposition is reversible, the permeability and retentive capacity can be restored by vigorous backwashing. Alternatively, the medium should be cheap and expendable.

A mathematical account of the theories of clarification with depth filters is found in the work of Ives (Ives, 1963; Ives, 1962) and Maroudas and Eisenklam (Maroudas and Eisenklam, 1965).

### **The Conditioning of Slurries**

The permeability of an ideal filter bed, such as that formed by a filter aid, is about  $7 \times 10^{-13} \text{ m}^2$ . This is more than 10,000 times the permeability of a precipitate of aluminum hydroxide. Therefore, the modification of the physical properties of the slurry can be a powerful tool in the hands of the filtration engineer. This is called slurry conditioning. Two methods, flocculation and the addition of filter aids, will be discussed here.

Flocculation of slurries is a common procedure in which the addition of flocculating agents is permissible. The aggregates or flocs, which are characterized by high sedimentation rate and sedimentation volume, form cakes with a porosity as high as 0.9. Since this is also associated with a decrease in specific surface, flocculation gives a marked increase in permeability. However, such coagulates are highly compressible and are, therefore, filtered at low pressures.

Filter aids are materials that are added in concentrations of up to 5% to slurries that filter only with difficulty. The filter aid forms a rigid cake of high porosity and permeability due to favorable shape characteristics, a low surface area, and a narrow particle size distribution, properties that can be varied for different operations. This structure mechanically supports the fine particles originally present in the slurry. Diatomite, in the form of a purified, fractionated powder, is most commonly used. Other filter aids include a volcanic glass, called "perlite," and some cellulose derivatives.

Filter aids cannot easily be used when the solids are wanted. Their excellent characteristics, however, lead to their use as a "precoat" mounted on a suitable support so that the filter aid itself forms the effective filtering medium. This prevents blinding of the septum. Precoat methods take several forms and are discussed in the section devoted to filters. A practical account of the properties and uses of filter aids has been given by Wheeler (Wheeler, 1964).

### **The Compressibility of Cakes**

In the theory of cake filtration described above, the permeability coefficient was considered constant. The observation that a cake may be hard and firm at the cake-septum junction and sloppy at its outer face suggests that the porosity may be varying throughout the depth of the cake. This could be due to a decrease in hydrostatic pressure from a maximum at the cake face to zero at the back of the supporting septum. The hydrostatic pressure must be balanced by a thrust, originating in the viscous drag of the fluid as it passes through the cake, transmitted through the cake skeleton, and varying from zero at the cake face to a maximum at the back of the septum equal to the pressure difference. The relation between this compressive stress and the pressure applied across the cake is represented in Figure 11.1.

We have so far considered that no deformation occurs under this stress, that is, the cake is perfectly rigid. No cake, in fact, behaves in this way. However, some, such as those composed of filter aids or, of coarse, isodiametric particles, approximate closely to a perfectly rigid cake. Others, such as cakes deposited

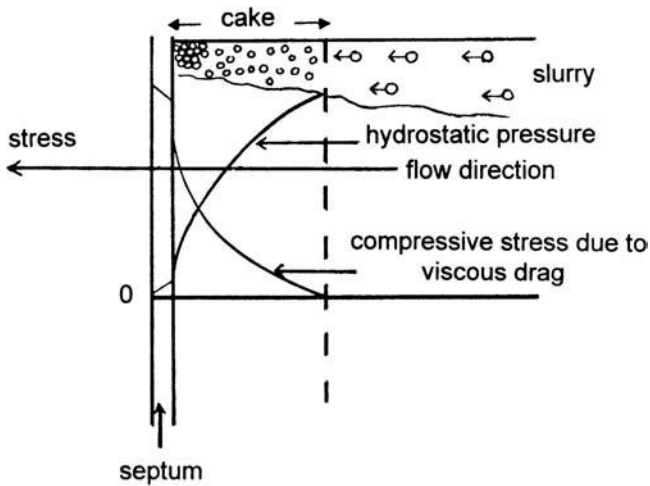

FIGURE 11.1 Stress distribution in a filter cake.

from slurries of heavily hydrated colloidal particles, are easily deformed, so the permeability coefficient, until now assumed constant, is itself a function of pressure, hence equation (1) no longer applies. This effect can be so marked that an increase in pressure actually decreases the rate of filtration. Most slurries behave in a manner intermediate between these two extremes.

### Cake Washing and Dewatering

Cake washing is of great importance in many filtration operations because the filtrate retained in the cake can be displaced by pure liquids. Filtration equipment varies in its washing efficiency, and this may influence the choice of plant. If the wash liquids follow the same course as the filtrate, the wash rate will be the same as the final rate of filtration, assuming that the viscosity of the two liquids is the same and that the cake structure is not altered by, for example, peptization following the removal of flocculating electrolytes. Washing takes place in two stages. The first involves the removal of most of the filtrate retained in the cake by simple displacement. In the second, longer stage, removal of filtrate from the less accessible pores occurs by a diffusive mechanism. These stages are shown in Figure 11.2.

Efficient washing requires a fairly cohesive cake, which opposes the formation of cracks and channels, which offer a preferential course to the wash liquid. For this reason, cakes should have even thickness and permeability.

Subsequent operations, such as drying and handling, are facilitated by removing the liquid retained in the cake after washing, which occupies from 40% to 80% of the total cake volume. This is achieved by blowing or drawing air through the washed cake, leaving liquid retained only as a film around the particles and as annuli at the points of contact. Since both surface area and the number of point contacts per unit volume increase as the particle size decreases, the effectiveness of this operation, like washing, decreases with cakes composed of fine particles.

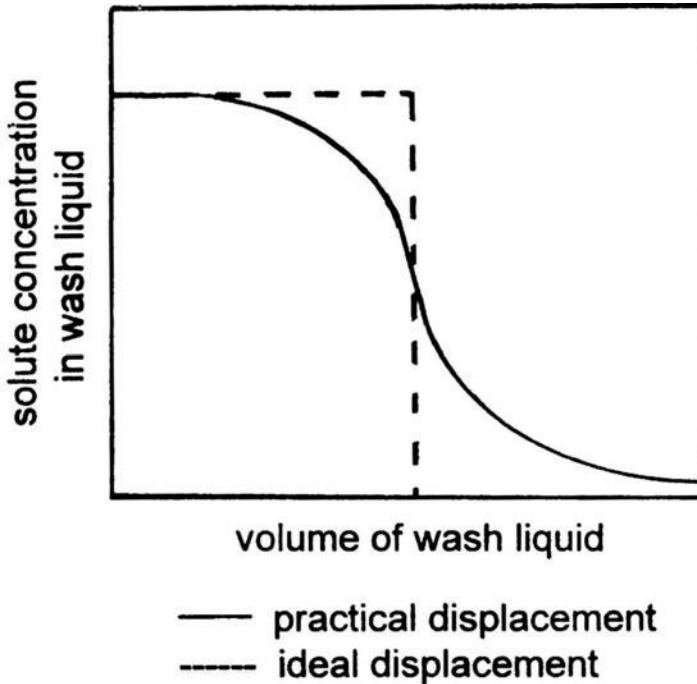

FIGURE 11.2 Displacement of filtrate by displacement washing.

## FILTERS

The method by which filtrate is driven through the filter medium and cake, if present, may be used to classify filters. Four groups may be listed: gravity filters, vacuum filters, pressure filters, and centrifuge.

Each group may be further subdivided into filters employed in either continuous or batch processes, although, because of technical difficulties, continuous pressure filters are uncommon and expensive. The general principles of each group are discussed below. These principles are illustrated by several widely used filters. More extensive surveys can be found in the literature (Salter and Hosking, 1958; Dickey, 1961).

### Gravity Filters

Gravity filters employing thick, granular beds are widely used in municipal water filtration. However, the low operating pressures, usually less than  $1.03 \times 10^4 \text{ N/m}^2$ , give low rates of filtration unless very large areas are used. Their use in pharmacy is very limited. Gravity filters using suspended media composed of thick felts are sometimes used for clarification on a small scale. On a somewhat larger scale, a wooden or stone tank, known as a nutsche, is used. The nutsche has a false bottom. This may act as the filter medium, although, more commonly, the bottom is dressed with a cloth. The slurry is added, and the material filters under its own hydrostatic head. The filtrate is collected in the sump beneath the filter. Thorough washing is possible either by simple displacement

and diffusion or by resuspending the solids in a wash liquid and refiltering. The nutsche is comparatively difficult to empty, and labor costs are high.

### Vacuum Filters

Vacuum filters operate at higher pressure differentials than gravity filters. The pressure is limited naturally to about  $8.27 \times 10^4 \text{ N/m}^2$ , which confines their use to the deposition of fairly thin cakes of freely filtering materials. Despite this limitation, the principle has been successfully applied to continuous and completely automatic cake filtration for which the rotary drum filter is most extensively used.

The rotary drum filter is illustrated in Figure 11.3. A typical construction may be regarded as two concentric, horizontal cylinders, the outer cylinder being the septum with a suitable perforated metal support. The annular space between the cylinders is divided by radial partitions producing a number of peripheral compartments running the length of the drum. Each compartment is connected by a line to a port in a rotary valve, which permits the intermittent application of vacuum or compressed air as dictated by the different parts of the filtration cycle. The drum is partially immersed in a bath to which the slurry is fed. The complete cycle of filtration, washing, partial drying, and discharge is completed with each revolution of the drum and usually takes from one to ten minutes. The relative length of each part of the cycle, indicated by the segments superimposed on the figure, will depend on the cake-forming characteristics of the slurry and the importance of the associated operations of washing and

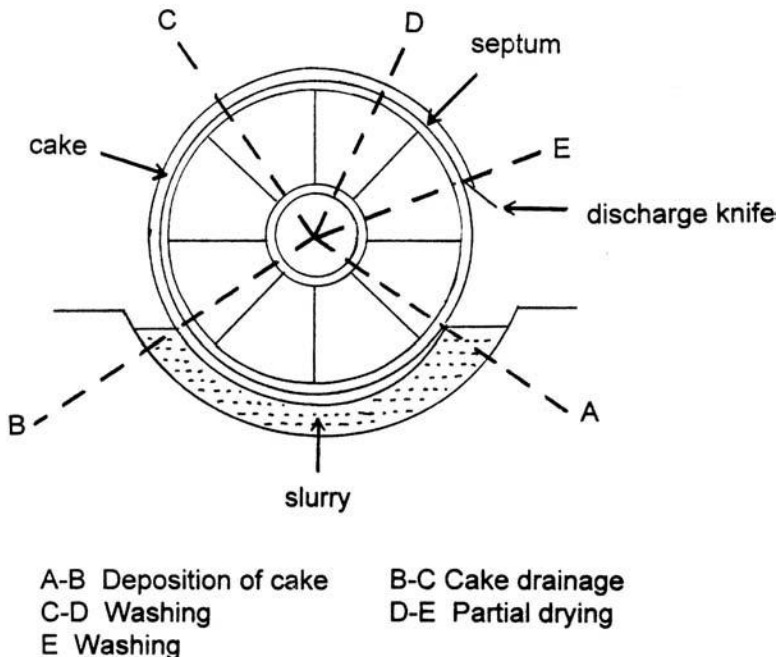

FIGURE 11.3 Rotary vacuum filter.

drying. They may be varied by the depth of immersion and the speed of rotation so that each compartment remains submerged for sufficient time for the formation of an adequate cake. Washing and dewatering can be carried out to the standard required during the remaining part of the cycle. The slurry must be effectively agitated during operation, or else sedimentation will cause the preferential deposition of the finer particles, giving a cake of low permeability. Agitation, of course, must not erode the deposited cake. Maintaining a suspension of very coarse particles therefore becomes difficult or impossible, and other methods of feeding must be adopted.

Filtration may be followed by a brief period of draining in which air is drawn through the cake, displacing retained filtrate. Washing is usually carried out with sprays, although devices that flood the cake have been used. Dewatering, again achieved by drawing air through the cake, is followed by discharge. A scraper knife, assisted by compressed air, which causes the septum to belly against the cutting edge, is commonly used. Highly cohesive cakes, such as those encountered in the removal of mycelial growth from antibiotic cultures, may be removed by means of a string discharge. A series of closely spaced, parallel strings run on the cloth around the drum. At the discharge section, the strings lift the cake away from the cloth and over a discharge roller after which the strings are led back to the drum.

Other variants of rotary drum filtration include top feed filtration and precoat filtration. As already mentioned, slurries containing coarse particles cannot be effectively suspended by the method described above. Such materials, which give rapid cake formation and fast dewatering, may be filtered by applying the slurry to the top of the drum using a feed box and suitable dams. Sedimentation, in this case, assists filtration.

Precoat filtration using a rotary drum is applied to slurries that contain a small amount of fine or gelatinous material, which plugs and blinds the filter cloth. Filtration is preceded by the deposition of a filter aid on the drum to a depth of up to 4 in. Blinding of the surface layers occurs during filtration, but these layers are removed at the discharge section by a slowly advancing knife so that a clean filtering surface is continually presented to the slurry. The depth of the cut depends on the penetration of the precoat by the slurry solids and is usually of the order of a hundred-thousandth of a meter. This method has allowed the filtration of slurries that could not previously be filtered or that demanded the addition of large quantities of a filter aid.

For filtration on a smaller scale, the nutsche is used. A vacuum is drawn on the sump of the tank, giving a much faster filtration rate than that in a gravity-operated process.

### **Pressure Filters**

Because of the formation of cakes of low permeability, many slurries require higher pressure differentials for effective filtration than that can be applied by vacuum techniques. Pressure filters are used for such operations. They may also be used when the scale of the operation does not justify the installation of continuous rotary filters. Usually, operational pressures of  $6.89 \times 10^4$  to  $6.89 \times 10^5$  N/m<sup>2</sup> are applied across stationary filter surfaces. This arrangement prohibits continuous operation because of the difficulty of discharging the cake while the filter is under pressure. The higher labor costs of batch operation are, however, offset by lower capital costs.

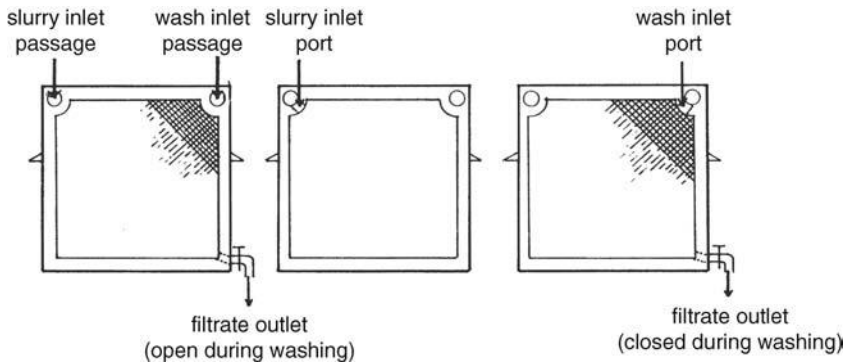

**FIGURE 11.4** The filter press: plates and frame. (A) Filter plate, (B) frame, and (C) washing plate.

The most commonly used pressure filter is the plate and frame filter press. It consists of a series of alternating plates and frames mounted in line on bars, which provide support and facilitate assembly and cake discharge. Typical plates and frames are shown in Figure 11.4.

The filter cloth is mounted on the two faces of each plate, and the press is assembled by moving the plates and frames together with a hand screw or hydraulic ram. This provides a series of compartments, the peripheries of which are sealed by the machined edges of the plates and frames uniting on the filter cloth, which acts as a gasket. Dripping often occurs at this point, so the press is less suitable for noxious materials. The dimensions of each compartment are determined by the area of the plates and the thickness of the intervening frame. These dimensions and the number of compartments used depend primarily on the volume of slurry to be handled and its solids content. The plate faces are corrugated by grooves or ribs, which effectively support the cloth, preventing distortion under pressure and allowing free discharge of the filtrate from behind the cloth. A section of the assembled filter press is given in Figure 11.5A.

Coincident holes, shown in the top left-hand corner of both plates and frames, provide, on assembly, a channel for the slurry and, simultaneously, enter into each compartment through an entry port in each frame. All compartments, therefore, behave in the same way with the formation of two cakes on the opposing plate faces. Discharge of filtrate after passage through cake, cloth, and corrugations takes place through an outlet in the plate shown diametrically opposite to the frame entry port. Filtration may be continued until the cake entirely fills the compartments or the accumulation of cake gives unsatisfactory rates of filtration.

Washing may be carried out by simply replacing the slurry by wash liquids and providing for its separate collection. This method, however, gives inefficient washing due to erosion and channeling of the cake. Where efficient washing is required, special washing plates alternate with the plates described above. These contain an additional inlet, which leads the wash liquid in behind the filter cloth. During washing, the filtrate outlet on the washing plate is closed so that the wash liquid flows through the cloth and first cake in a direction opposite to that taken by the filtrate. The wash liquid then follows the course of the filtrate through the cake and cloth of the opposite plate. A diagrammatic representation of the flow of liquids during washing is given in Figure 11.5B.



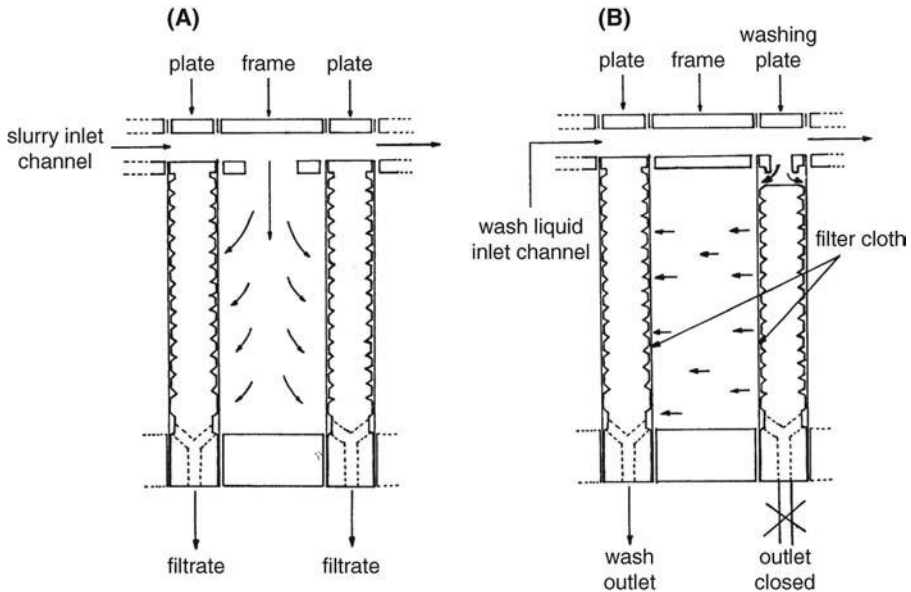

**FIGURE 11.5** The filter press assembled press showing a frame and two plates. Movement of liquid during (A) filtration and (B) washing.

The development of filter media in sheet form with high wet strength and the ability to retain extremely fine particles extends the application of the plate and frame filter to clarification. Such media occur in various grades and, when used in apparatus similar to that described above, may be used to clarify or sterilize liquids containing a very low proportion of solids. In sterilization by sheet filtration, the operation is carried out in two stages. The solution is first clarified. The very clean filtrate is then passed through the sterilizing sheet under a relatively low pressure. Before the operation, the assembled filter is sterilized by steam. The washing apparatus, assembled with suitable sheets, may also be used for air filtration.

Other filters widely used for clarification are the metafilter and the streamline filter. The former consists of a large number of closely spaced rings, usually made of stainless steel, mounted on a rod. The rod is fluted to provide channels for the discharge of filtrate. The passage of filtrate between the rings is provided by scallops stamped on one side of each ring and maintains a ring spacing of between one and eight hundred-thousandths of a meter. This construction provides a robust support for the actual filtering medium. It is mounted in a suitable pressure vessel, and large filters consist of a number of units. For clarification, the filter is first coated by circulating filter aid of the correct grade. The finest materials are suitable for the removal of bacteria. The coat acts as a depth filter. Filter aids may also be added to the liquid to be clarified.

The "streamline" filter employs paper disks compressed to form a filter pack. The filtrate passes through the minute interstices between the disks, leaving any solids at the edge. This is the principle of edge filtration. Other

filters, composed of metal plates or wires, operate on the same principle and are used for coarse clarification.

Many small-scale filters consist simply of a fixed, rigid medium, robust enough to withstand limited pressures, mounted in a suitable housing. Such filters, which are also vacuum operated, are used to clarify by depth filtration. Media are composed of sintered metals, ceramics, plastics, or glass. Filters prepared from closely graded and sintered ceramic powders are suitable for the sterilization of solutions by filtration on a manufacturing scale.

### **FILTER MEDIA**

The choice of filter medium for a particular operation demands considerable experience. In clarification, high filtration rates and the retention of fine particles are opposing requirements. Permeability and retentive capacity can be determined and used to guide small-scale experiments with the materials to be filtered, facilities for which are often made available by filter manufacturers. Other relevant factors are the contamination of the filtrate by the medium and associated housing, the adsorption of materials from solutions, and, where necessary, the ability of the medium to withstand repeated sterilization.

In cake filtration, the medium must oppose excessive penetration and promote the formation of a junction with the cake of high permeability. The medium should also give free discharge of cake after washing and dewatering.

#### **Rigid Media**

Rigid media may be either loose or fixed. The former is exemplified by the deposition of a filter aid on a suitable support. Filtration characteristics are governed mainly by particle size, size distribution, and shape in a manner described earlier. These factors may be varied for different filtering requirements.

Fixed media vary from perforated metals used for coarse straining to the removal of very fine particles with a sintered aggregate of metal, ceramic, plastic, or glass powder. The size, size distribution, and shape of the powder particles together with the sintering conditions control the size and distribution of the pores in the final product. The permeability may be expressed in terms of the constant given in equation (1). Alternatively, the medium may be characterized by air permeability. The maximum pore size, which is important in the selection of filters for sterilization, may be determined by measuring the pressure difference required to blow a bubble of air through the medium while it supports a column of liquid with a known surface tension. Full details of methods used for the measurement of air permeability and maximum pore diameter are given in British Standard BS 1752:1963.

#### **Flexible Media**

Flexible media may be woven or unwoven. Filter media woven from cotton, wool, synthetic and regenerated fibers, glass, and metal fibers are used as septa in cake filtration. Cotton is most widely used, while nylon is predominant among synthetic fibers. Terylene is a useful medium for acid filtration. Penetration and cake discharge are influenced by twisting and plying of fibers and by the adoption of various weaves such as duck and twill. The choice of a particular cloth often depends on the chemical nature of the slurry.

Nonwoven media occur in the form of felts and compressed cellulose pulps and are used for clarification by depth filtration. A disadvantage, unless carefully prepared, is the loss of fibrous material from the downstream side of the filter. The application of sheet media has already been discussed. High wet strength is conferred on paper sheets by resin impregnation. An alternative manufacture employs asbestos fibers supported in a cellulose framework.

### THE FILTRATION OF AIR

Removal of particulate matter from air together with control of humidity, temperature, and distribution comprise air conditioning. Solid and liquid particles are most commonly arrested by filtration, although other methods, such as electrostatic precipitation, cyclones, and scrubbers, are used in some circumstances. The objective may be simply the provision of comfortable and healthy conditions for work or may be dictated by the operations proceeding in the area. Some industrial processes demand large volumes of clean air.

In this section, we shall be concerned mainly with air filtration, the objective of which is the reduction in number or complete removal of bacteria. This is applied, with varying stringency, to several operations associated with pharmacy. Where sterilization is the objective and the presence of inanimate particles is of secondary importance, other methods, such as ultraviolet radiation and heating, must be added.

Bacteria rarely exist singly in the atmosphere but are usually associated with much larger particles. For example, it has been shown that 78% of particles carrying *Clostridium welchii* were greater than  $4.2 \times 10^{-6}$  m. The average diameter exceeded  $10 \times 10^{-6}$  m. On this basis, it has been suggested that air filters that are 99.9% efficient at  $5 \times 10^{-6}$  m are adequate for filtration of air supplied to operating theaters and dressing wards (Williams et al., 1961). On the other hand, filters used to clean air supplied to large-scale aerobic fermentation cultures must offer a very low probability that any organism will penetrate during the process. This became important in the deep-culture production of penicillin when the ingress of a single penicillinase-producing organism could be disastrous. Similarly, stringent conditions are laid down for the supply of air to areas where sterile products are prepared and handled.

### The Mechanism of Air Filtration

A theoretical foundation for the filtration of air by passage through fibrous media was laid in the early 1930s by studies of the flow of suspended particles around various obstacles. In studies of the filtration of smokes (Suits, 1961; Hinds, 1999), it has been shown that a number of factors operate simultaneously in the arrest of a particle during its passage through a filter, although their relative importance varies with the type of filter and the conditions under which it is operated. These factors may be listed as follows:

- Diffusion effects due to Brownian movement
- Electrostatic attraction between particles and fibers
- Direct interception of a particle by a fiber
- Interception as a result of inertial effects acting on a particle and causing it to collide with a fiber
- Settling and gravitational effects

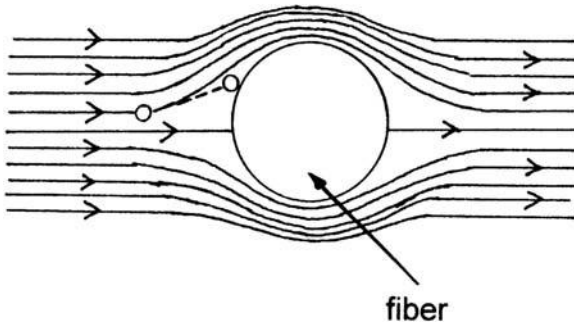

**FIGURE 11.6** Inertial capture of a particle by a fiber.

Air filters operate under conditions of streamline flow, as indicated by the streamlines drawn around a cylindrical fiber shown in cross section in Figure 11.6. It was assumed that capture of a particle takes place if any contact is made during its movement around the fiber. Once capture occurs, the particle is not re-entrained in the airstream and is deposited deeper in the bed. Support for this assumption has been found by using an atomized suspension of *Staphylococcus albus* and spores of *Bacillus subtilis* (Terjesen and Cherry, 1947). Nevertheless, some fiber filters are treated with viscous oils, presumably to make capture more positive and to reduce re-entrainment.

If a particle remains in a streamline during passage around the fiber, capture will occur only if the radius of the particle exceeds the distance between streamline and fiber, a dimension dependent on the diameters of the particle and the fiber. This mechanism, termed "capture by direct interception," is independent of the air velocity except in so far as the streamlines are modified by changes in air velocity.

Deviation of particles from streamlines can occur in a number of ways (Hinds, 1999; Reist, 1993). The chance of capture will increase if Brownian movement causes appreciable migration across streamlines, an effect only important for small particles ( $<5 \times 10^{-7}$  m) and low air speeds, when the time spent in the vicinity of a fiber is relatively large. These conditions also apply to capture, which is the result of electrostatic attraction.

The inertial mechanism depends on the mass of the particle, the fiber diameter, and the velocity of approach. The particle deviates from the streamline and follows the broken line shown in Figure 11.6. Capture occurs if the deviation, which increases as the mass and velocity of the particle increase, brings the particle into contact with the fiber.

The simultaneous operation of mechanisms, at least one of which demands low air speeds and fine particles for effectiveness and another which requires large particles traveling at high speeds, suggests that maximum penetration could occur at an intermediate air speed. Conversely, there is, for any given conditions, an optimal particle size for which the combined filtration effects are a minimum and penetration is a maximum. The former was confirmed with a variety of inanimate aerosols. A diagrammatic representation of the interaction of mechanisms was also given, and this is reproduced in Figure 11.7.

Similar effects were demonstrated for bacterial aerosols (Humphrey and Gaden, 1956). Estimated the efficiency with which a glass fiber mat collected

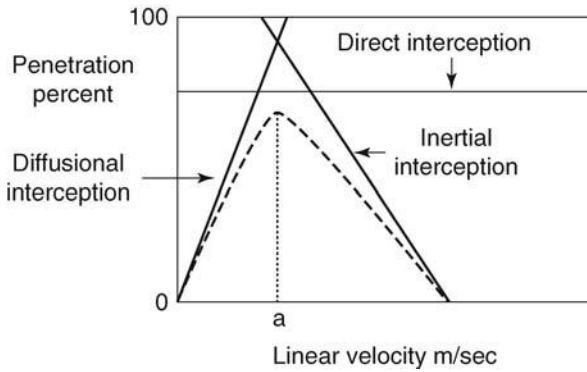

**FIGURE 11.7** Interaction of the mechanisms of particle arrest.

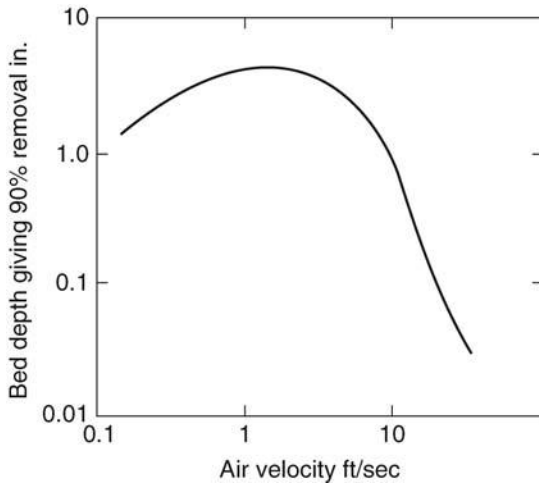

**FIGURE 11.8** Effect of airstream velocity on the removal of bacterial spores by a filter.

*B. subtilis* spores atomized as particles just over 1 μm in radius. The results are presented in Figure 11.8. A theoretical approach to the removal of industrial dusts has been developed (Stairmand, 1950; Fuchs, 1964).

**The Design, Operation, and Testing of Air Filters**

Granular beds, fibrous media, and “absolute filters” prepared from cellulose and asbestos are used for high-efficiency air filtration. With fibrous and granular filters, the fractional reduction in particle content is assumed to be the same through successive incremental thicknesses of the filter. We may, therefore, rewrite equation (2).

$$\frac{dC}{dx} = -kC$$

where *C* represents the number of particles entering a section of thickness *dx*. The constant, *k*, is a measure of the filter’s ability to retain a particle and is a

complex function of fiber diameter, interfiber distance, and operational air velocity. Integration between inlet and outlet conditions gives

$$\log \frac{C_{\text{out}}}{C_{\text{in}}} = -kx \quad (11.3)$$

The use of this log penetration effect in filter design has been described elsewhere (Gaden and Humphrey, 1955). If a certain filter thickness is capable of retaining 90% of the entering particles, then if  $10^6$  particles enter,  $10^5$  will penetrate. If six thicknesses are used, then the relation above predicts that only one particle will penetrate. The log penetration effect has been confirmed for fibrous filters and for granular beds (Humphrey and Gaden, 1956; Cherry et al., 1951), respectively. It must be stressed, however, that both fibrous and granular filters present passages very much greater than the fine particles they remove. Absolute sterility or absolute filtration at a certain particle size cannot be achieved. However, design variables, such as the fiber diameter, the density with which fibers are packed, the thickness of the filter, and the air speed. For example, these variables may be varied to give air that, for a given input contamination, is, with a high statistical probability, sterile.

In an early study, Terjesen and Cherryl used a bacterial aerosol and a Bourdillon slit sampler to test the suitability of filters for air sterilization (Terjesen and Cherryl, 1947). They showed that 0.075-m slabs of slag wool composed of fibers, most of which were less than  $6 \times 10^{-6}$  m and compressed to a suitable density, gave sterile air when operated for fifteen days at a face velocity of 0.152 m/sec. A similar efficiency was found for filters composed of glass fibers of similar diameters (Cherry et al., 1951). Resin-bonded filter mats composed of glass fibers,  $12 \times 10^{-6}$  to  $13 \times 10^{-6}$  m in diameter, have also been described. A number of these mats assembled to give a filter 0.304 m deep were effective in the removal of bacteria.

Bacteria may be effectively removed by passing air through deep granular beds of activated carbon, alumina, and other materials. Table 11.1 gives data on the efficiency of alumina in a bed 0.381 m deep for the removal of *Serratia marcescens* from air (Sykes and Carter, 1954). The effect of two design variables, granule size and air speed, is illustrated.

The extremely hazardous nature of radioactive dusts has promoted the design of high-efficiency air filters for use in establishments where such materials are handled. These filters may be used for any application requiring extremely pure air. The evolution of filters that remove 99.995% of particles in the range  $1 \times 10^{-7}$  to  $5 \times 10^{-7}$  m has been described by White and Smith (White and Smith, 1960). A medium in paper form was constructed from cellulose and asbestos. This could be pleated round corrugated spacers to give a large filtering area in a relatively small space. A paper composed of very fine glass fibers was

**TABLE 1** Removal of *Serratia marcescens* with a 0.3-m Bed of Alumina Granules

Air velocity (m/min)	Efficiency (percent removal)	
	8–16 mesh	16–32 mesh
24.4	–	92
73.2	88	99.4
146.3	98.7	99.9
219.5	99.86	–

Source: From Sykes and Carter, 1954.

later developed, which resisted temperatures of up to 773 K and could, therefore, be sterilized.

The general object of design in all filters is the virtual certainty of removing the particles under consideration with a medium offering minimal resistance to the flow of air. Unlike liquid clarifiers, air filters become more efficient with time because accumulation of particles restricts the passages through the medium. This deposition causes an increase in the pressure differential required to maintain a given flow rate. When the filter has become laden with a certain amount of dust, it must be cleaned or replaced. The life of high-efficiency air filters may be lengthened by passing the air first through a coarse or "roughing" filter, which removes the larger particles.

The use of bacterial aerosols as tracer organisms to test the efficiency of filters has already been described. Other tests with inanimate dusts are more generally used for the evaluation of filter performance. For general ventilation purposes, two tests are specified. The first determines gravimetrically the capacity of the filter to hold dust and still function satisfactorily. A standard dust of  $5 \times 10^{-6}$  or  $26 \times 10^{-5}$  m is passed into the filter until a specified increase in air flow resistance occurs. The second test, which is also applicable to high-efficiency filters, determines the fraction of a methylene blue aerosol that passes through the filter under given conditions. The aerosol is generated by atomizing a 1% aqueous solution of methylene blue. The droplets dry to give a cloud of particles, 90% of which are below  $2 \times 10^{-7}$  m. The test is, therefore, extremely stringent. The cloud is passed through the filter at a constant rate ( $10^{-3}$  m<sup>3</sup>/min) and then through a strip of porous paper, which collects any methylene blue particles that have penetrated. The stain due to the dye, after intensification in steam, is compared with a series of similar stains that correspond to known volumes of unfiltered air. Thus, if  $60 \times 10^{-3}$  m<sup>3</sup> of filtered air gives a stain that matches that produced by  $1.2 \times 10^{-5}$  m<sup>3</sup> of unfiltered air, the penetration is 0.02% (Green and Lane, 1957). Both tests are fully described in BS 2831:1957. An alternative method of evaluating penetration employs a cloud produced by the atomization of a solution of sodium chloride. After passage through the filter, part of the air is passed through a hydrogen flame. The intensity of the sodium flame produced is estimated with a photoelectric cell.

## THE CENTRIFUGE

An object moving in a circular path is subjected to an outward centrifugal force, which balances the centripetal force moving the object toward the center of rotation. This principle is used in the mechanical separations called centrifugal filtration and centrifugal sedimentation. In the former, a material is placed in a rotating perforated basket, which is lined by a filter cloth. This is used to separate a solid, which is retained at the cloth, from a liquid. It is essentially a filtration process in which the driving force is of centrifugal origin. It, in no way, depends on a difference in the densities of the two phases.

In centrifugal sedimentation, the separation is due to the difference in the density of two or more phases. In this more important process, both solid-liquid mixtures and liquid-liquid mixtures can be completely separated. If, however, the separation is incomplete, there will be a gradient in the size of the dispersed phase within the centrifuge due to the faster radial velocity of the larger particles. Operated in this way, the centrifuge becomes a classifier.

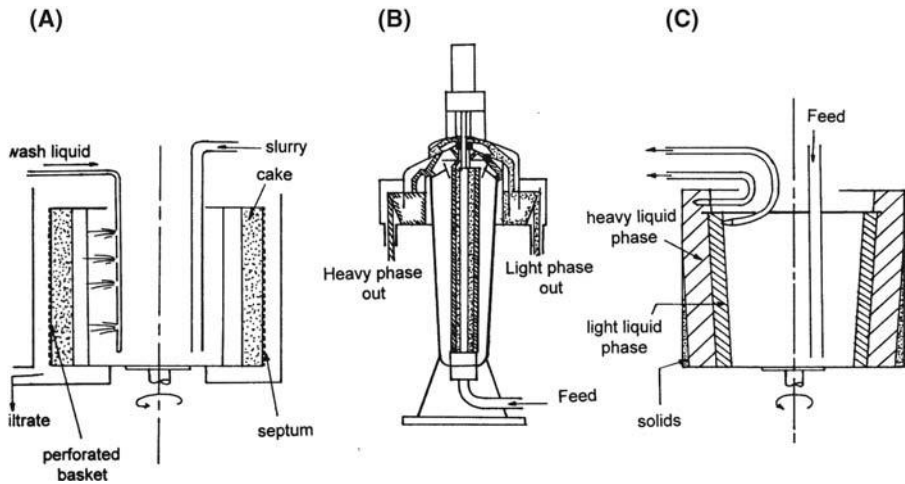

FIGURE 11.9 (A) Batch centrifugal filter, (B) supercentrifuge, and (C) solid-bowl batch centrifuge.

### Centrifugal Filtration

The principles of filtration discussed previously can be directly applied to this process, although theoretical predictions of filtration rate and spinning time are uncertain. The process is widely used for the separation of crystals and granular products from other liquors, but it is less effective if the slurry contains a high proportion of particles less than  $1 \times 10^{-4}$  m. The advantages of the process are effective washing and drying. Residual moisture after centrifugation is far less than that in cakes produced by pressure or vacuum filtration. By this method, the moisture content of a cake of coarse crystals can be reduced to as low as 3%. This facilitates the drying operation that normally follows. Enclosure of the centrifuge is easy so that toxic and volatile materials can be processed.

A typical batch filter is shown in Figure 11.9A. It consists of a perforated metal basket mounted on a vertical axis. The cloth used to retain solids is often supported on a metal screen. Baskets mounted in the manner shown are emptied by shoveling the cake. If, however, top suspension is used, the cake can be more easily withdrawn through traps in the base of the basket. In batch operation, considerable time is lost during the acceleration and deceleration of the machine. Machines operating with continuous discharge of solids are used for separation of coarse solids when the scale of the operation is large. Such machines are commonly constructed with a horizontal axis of rotation.

### Centrifugal Sedimentation

The motion of a particle in a liquid is described by Stokes' equation. If its diameter is  $d$ , the rate,  $u$ , at which it settles by gravity in a liquid of viscosity  $\eta$  and density  $\rho$  is given by equation (24) in chapter 2 as

$$u = \frac{1}{18} d^2 \frac{\rho_s - \rho}{\eta} g$$

where the acceleration due to gravity is  $g$  and the density of the particle is  $\rho_s$ . In the centrifuge, the gravitational force causing separation is replaced by a



centrifugal force. If the particle has a mass  $m$  and moves at an angular velocity  $\omega$  in a circle of radius  $r$ , the centrifugal force will be  $\omega^2 r(m - m_1)$ , where  $m_1$  is the mass of the displaced liquid.  $\omega^2 r/g$  is, therefore, the ratio of the centrifugal and gravitational forces in the example described above. Its value can exceed 10,000. The separation is, therefore, quicker, more complete, and effective in systems containing very fine particles, which will not sediment by gravity because of Brownian movement.

Expressing the mass of the particle in terms of its volume and effective density, the centrifugal force can be written as

$$\frac{\pi}{6} d^2 (\rho_s - \rho) \omega^2 r \quad (11.4)$$

In streamline conditions, the opposing viscous force, given by equation (22) in chapter 2, is  $3\pi\eta du$ ,  $u$  being the terminal velocity of the particle. Equating these expressions,

$$u = \frac{1}{18} d^2 \left( \frac{\rho_s - \rho}{\eta} \right) \omega^2 r \quad (11.5)$$

The rate of sedimentation is proportional to the radius of the basket and the square of the speed at which it rotates. Centrifugal sedimentors can be divided into a number of types.

For operation at very high speeds, the centrifuge bowl is tubular with a length-diameter ratio ranging from 4 to 8. An example is the Sharples super-centrifuge illustrated in Figure 11.9B, which operates at up to 15,000 rpm or, in turbine-driven laboratory models, up to 50,000 rpm. The machine, which gives continuous discharge of two separated liquids, is widely used for the separation of emulsions. It is also an effective clarifier when the concentration of solids is very low. These are periodically discharged by scraping the walls of the centrifuge tube. Uses include the cleaning of fats and waxes, the fractionation of blood, and the recovery of viruses.

Disk-type centrifuges introduce baffles into the bowl to decrease the distance that particles travel before settling at the wall. These split the liquid into a number of layers in which separation occurs. The length to diameter ratio is usually much smaller than that in tubular-bowl centrifuges, and operational speeds are lower. In batch processes, the machine is discharged manually at intervals. Larger machines continuously or intermittently discharge the solids as a thick slurry through nozzles or valves at the periphery of the basket.

A solid-bowl batch basket is shown in Figure 11.9C. In this type of machine, liquids are discharged by weirs or skimmers. In the figure, two skimmers are shown, each taking off a liquid phase. Solids are discharged manually at the end of the process. In continuous models, a conveying scroll, operating at a slightly different speed from the basket, plows the solids to one end, discharging the material as a damp powder.

**THE IMPORTANCE OF FINE PARTICLES IN PHARMACY**

Although fine particles can be produced directly by controlled precipitation, crystallization, or drying a fine spray of solution, in many cases the material is powdered in some kind of mill. From our point of view, the most important result of this operation is the increase in the surface area of a given weight of the powder and its influence on diffusional processes. A cube of side 0.01 m has a surface area of  $6 \times 10^{-4} \text{ m}^2$ . If, by some ideal size reduction process, this cube was divided into cubes of side 0.001 m, we should have a thousand particles each with a surface area of  $6 \times 10^{-6} \text{ m}^2$  and a total surface area of  $6 \times 10^{-3} \text{ m}^2$ . A tenfold increase in surface area has been given by a tenfold decrease in particle size. Generalizing, we may say that the surface area is inversely proportional to the particle size assuming that the shape of the particles remains the same.

The rate of most chemical and physical reactions involving solids and liquids is greatly influenced by the area of interfacial contact. In chemical reactions, a reagent must diffuse toward the surface of the solid and the reaction products away, a procedure that depends, among other things, on the area between solid and liquid. The effect of particle size on dissolution rate exemplifies another aspect of diffusion that is of importance to the pharmacist. Most commonly, drugs are taken orally in the form of solid particles, and absorption, which is usually rapid, must be preceded by dissolution. A full discussion of the role of particle size in oral, parenteral, and topical therapies may be found in reviews (Newman and Axon, 1961; Wagner, 1961).

The rate at which fine chemicals or drugs are extracted from a vegetable source is increased by an increase of surface area. Reduction of particle size increases the area available for transfer of materials and decreases the distance over which solvent and solute must diffuse and has a marked effect on the drying of porous materials.

Other effects, not based on diffusion and its dependence on surface area, are found in mixing and various formulation requirements. If we withdraw a sample from a mixture of powders, it is unlikely to contain exactly the correct proportion of ingredients. However, the larger the number of particles in the sample, the closer the sample will represent the overall proportions of the mixture. We can therefore increase the accuracy of the sample, which might eventually form a tablet or a capsule, by increasing the number of particles it contains, that is, reducing the particle size of the components of the mix. Since difference of particle size will promote segregation, the components should be produced with a similar particle size distribution.

Formulation requirements often dictate the use of fine particles. Impalpability and spreading are required of dusting and cosmetic powders. Particles of  $3.5 \times 10^{-5}$  to  $4.0 \times 10^{-5} \text{ m}$  can be detected as single particles when applied to the skin and may give the impression of grittiness. Such powders should, in general, be finer than  $3.0 \times 10^{-5} \text{ m}$ . When powders are tinted, the particle size of powder and pigment affects the final color. In tableting, careful size reduction of imperfect tablets provides a material suitable for compression. The flow

properties of suspensions of high disperse phase concentration are affected by particle size and size distribution. At a given disperse phase concentration, decrease of particle size gives an increase in viscosity, while a broadening of particle size distribution yields a decrease in viscosity. Sedimentation is a function of particle size.

Numerous examples have been quoted to stress the importance of fine particles in pharmacy. Milling or grinding offers a method by which these particles may be produced, size classification gives a means, where applicable, of selecting a desired fraction or of removing oversize or undersize particles, and size analysis provides the analytical tool by which these operations may be assessed and controlled.

### FUNDAMENTAL ASPECTS OF CRUSHING AND GRINDING

A basic study of crushing and grinding considers the physical properties of the material, the crushing mechanism itself, and its relation to the mechanism of failure. When a stress, which may be compressive, tensile, or shear, is applied to a solid, the latter deforms. Initially, the deformation or strain is the distortion of the crystal lattice by relative displacement of its components without change of structure. Complete recovery follows the removal of the stress, and behavior is elastic. Figure 12.1 considers the deformation of a solid under a tensile stress, and elastic behavior is shown over section AB. Below the elastic limit, B, stress is proportional to strain and is related to it by various moduli. Beyond the yield point, C, permanent or plastic deformation occurs and, as shown by release of stress at point D, all strain is not recoverable. Sliding along natural cleavage planes is occurring in this region. Plastic deformation is terminated by failure or fracture, which is normally a quite gradual and reproducible process preceded by thinning of the material. The stress at point E is a measure of the strength of the material. The area under the curve at any point represents the strain energy per unit volume absorbed by the specimen up to that strain. The limiting strain energy per unit volume is the energy absorbed up to the point of failure.

An extensive period of plastic deformation is shown in Figure 12.1, and the material would be classified as ductile. For the brittle materials normally

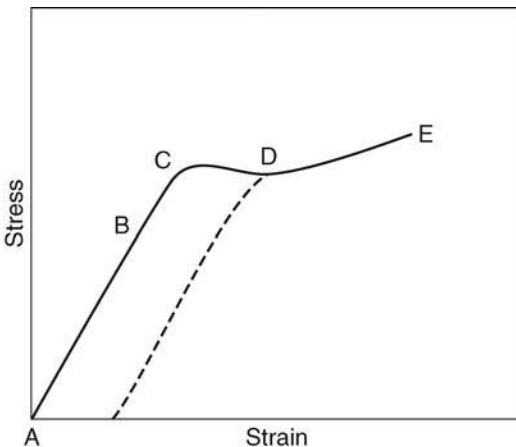

**FIGURE 12.1** The tensile deformation of a ductile material.

encountered in grinding, little plastic deformation takes place and the points C and E almost coincide. Fracture is explained here in terms of cracks and flaws naturally present in the material. It occurs suddenly and with shattering. The energy employed in stressing the particle to the point of failure reappears mainly as heat on release of strain in a manner analogous to the sudden release of a stressed spring.

The theoretical strength of crystalline materials can be calculated from interatomic attractive and repulsive forces. The strength of real materials is, however, found to be many times smaller than the theoretical value. The discrepancy is explained in terms of flaws of various kinds, such as minute fissures or irregularities of lattice structure known as dislocations. These have the capacity to concentrate the stress in the vicinity of the flaw. Failure may then occur at a much lower overall stress than is predicted from the theoretical considerations. Failure occurs with the development of a crack tip, which propagates rapidly through the material, penetrating other flaws, which may, in turn, produce secondary cracks. The strength of the material therefore depends on the random distribution of flaws and is a statistical quantity varying within fairly wide limits. This concept explains why a material becomes progressively more difficult to grind. Since the probability of containing an effective flaw decreases as the particle size decreases, the strength will increase until, with the achievement of faultless domains, the strength of the material will equal the theoretical strength. This position is not realized in practice because of complicating factors such as aggregation.

The strength of most materials is greater in compression than in tension. It is therefore unfortunate that technical difficulties prevent the direct use of tensile stresses. The compressive stresses commonly used in comminution equipment do not cause failure directly but generate, by distortion, sufficient tensile or shear stress to form a crack tip in a region away from the point of primary stress application. This is an inefficient but unavoidable mechanism. Impact and attrition are the other basic modes of stress application. The distinction between impact and compression is referred to below. Attrition, which is commonly employed, is difficult to classify but is probably, primarily, a shear mechanism.

In any machine, one mode of stress application usually predominates. It must be correctly chosen with respect to the mechanical properties of the material. Compression, for example, is useless for comminution of fibrous or waxy solids. Attrition is generally necessary for all fine grinding.

The deformation and subsequent failure of a brittle material is a function not only of stress but also of the rate at which the stress is applied. Different results may be obtained from slow compressive breaking and impact breaking at the same energy. Particle shape, size, and size distribution may be affected. In impact breaking, the rate of stress application is so high that the limiting strain energy may be exceeded several times by the suddenness of the operation. This is because fracture is time dependent, a lag occurring between the application of maximum stress and failure.

Stress application is further complicated by "free-crushing" and "packed-crushing" mechanisms. In free crushing, the stress is applied to an unconstrained particle and released when failure occurs. In packed crushing, the application of stress continues on the crushed bed of particles. Although further size reduction occurs, the process is less efficient because of vitiation of energy by the effects of interparticulate friction and stress transmission via particles that

do not themselves fracture. This is easily demonstrated when a crystalline material is ground in a pestle and mortar. The fine powder initially produced protects coarser particles. If the material is sieved and oversize particles are returned, the operation may be completed with far less effort.

Free crushing is most nearly approached in the roller mill, which explains the high efficiency of the machine, and, to a lesser extent, in other continuous processes in which individual particles are presented to the grinding media. Packed crushing occurs in ball mills.

### THE EFFICIENCY OF GRINDING

Extensive investigation of the relation between the energy supplied to a mill and the size reduction achieved has been carried out. The efficiency of the process reflected by such a relation is of small importance in pharmacy because the applications are limited. For completeness, however, they are considered below.

Most of the energy supplied to the mill is ultimately dissipated as heat because of mechanical inefficiency. Most of the remainder or net grinding energy also appears as heat produced upon the release of strain energy, a small part being added to the internal energy of the system as, for example, surface energy.

Various hypotheses relate the net grinding energy applied to a process and the size reduction achieved. The first, proposed by Karl von Rittinger in 1867, states that the energy necessary for size reduction is directly proportional to the increase in surface area.

$$E = k(S_p - S_f) \quad (12.1)$$

where  $E$  is the energy consumed, and  $S_p$  and  $S_f$  are the surface areas of product and feed materials, respectively. The constant,  $k$ , depends on the grinding unit employed and represents the energy consumed in enlarging the surface area by one unit. The relation between surface area and particle size has already been derived, and we may therefore write

$$E = k \left( \frac{1}{d_p} - \frac{1}{d_f} \right) \quad (12.2)$$

where  $d_f$  and  $d_p$  are the particle sizes of feed and product particles, respectively.

The hypothesis indicates that energy consumption per unit area of new surface produced increases faster than the linear ratio of feed and product dimensions, a phenomenon already noted and explained. The proportionality of net energy input and new surface produced has been confirmed in some grinding operations.

Although Rittinger's law is concerned with surfaces and not the energy associated with those surfaces, it is rational to relate crushing energy consumed and the surface energy gained by increase of surface area, thereby arriving at a measure of efficiency. In experiments in which single particles are crushed, between 1% and 30% of the applied energy appears as surface energy. In practical systems, when application of stress is less ideal, the net grinding energy is 100 to 1000 times greater than that associated with the new surface, that is, the efficiency of the process, on this basis, is between 0.1% and 1%.

The relation of energy to surface area provides little information on the grinding process and does not influence mill design. It, however, provides the basis of some grindability tests in which a known amount of energy is supplied to a mill and the increase in surface is measured. This application is restricted to fine grinding.

Conversion of grinding energy to surface energy is neglected in Kick's law, enunciated in 1885. The law is based on the deformation and brittle failure of elastic bodies and states that the energy required to produce analogous changes of configuration of geometrically similar bodies is proportional to the weight or volume of those bodies. The energy requirements are independent of the initial particle size and depend only on the size reduction ratio. Kick's law predicts lower energies than the relation proposed by Rittinger. The theory, however, demands that the resistance to crushing does not change with particle size. The role of flaws present in real materials is not considered with the result that the energy required for fine grinding, when the apparent strength may have greatly risen, is underestimated.

A third theory of comminution gives results intermediate between the predictions of the laws of Kick and Rittinger (Bond, 1952). The theory rests on three principles, the first of which states that any divided material must have a positive energy register. This can only be zero when the particle size becomes infinite. The input energy,  $E$ , for any size reduction process then equals the product energy register minus the feed energy register. The energy associated with a powder increases as the particle size decreases, and we may assume that the energy register is inversely proportional to the particle size to an exponent,  $n$ . Hence,

$$E = E_p - E_f = \frac{K}{d_p^n} - \frac{K}{d_f^n} \quad (12.3)$$

The second principle of Bond's theory assigns to  $n$  a value of  $i$ , stating that "total work useful in breaking which has been applied to a stated weight of an homogeneous material is inversely proportional to the square root of the diameter of the product particles."

The third principle states that breakage of the material is determined by the flaw structure. This aspect of size reduction has already been discussed.

A modification to Kick's law, sometimes known as the fourth law of comminution, has also been proposed. For its discussion, the reader is referred to the original paper (Holmes, 1957)

An empirical but realistic approach to mill efficiency is gained through experiments in which the energy consumed and size reduction achieved are compared with values obtained in a laboratory test operating under free-crushing conditions. All energy supplied in the latter is available for crushing, and the test is assumed to be 100% efficient. Both slow crushing and impact tests are used. A large number of single particles may be simultaneously crushed, and the work done may be measured (Carey and Stairand, 1953). The latter is then related to the size reduction achieved. Similar measurements can be made during practical milling, expressing the efficiency of the process as a percentage of the free-crushing value. On this basis, approximate efficiency of the roll crusher is 80%, that of the swing hammer mill is 40%, that of the ball mill is 10%, and that of the fluid energy mill is only 1%.

## THE OPERATION OF MILLS

In some operations, such as those in which ores are processed, size reduction may constitute a major proportion of total process costs. The efficiency with which energy is utilized is, therefore, of great importance. Drugs, on the other hand, fall into a class of materials that are high in cost and are processed in relatively small quantities. The contribution of grinding to total costs is, therefore, smaller, and the choice of machine can usually be made on technological rather than economic grounds. Generally, drugs are easy to grind. The operation is classified as fine grinding if the bulk of the product passes a 200-mesh screen ( $7.6 \times 10^{-5}$  m) or as superfine grinding if a powder of a few microns or less is required. Most pharmaceutical grinding falls into these classes, although coarser grinding is applied to vegetable drugs before extraction.

Heywood has stated that any type of crushing or grinding machine exhibits optimal comminution conditions for which the ratio of the energy to new surface is minimal (Heywood, 1957). If finer grinding is attempted in such a machine, the ratio will be increased. Mills may thus become grossly inefficient if called upon to grind at a size for which they were not designed. A limited size reduction ratio is imposed upon a single operation, larger ratios being obtained by the adoption of several stages, each employing a suitable mill. The fluid energy mill, which presents a size reduction ratio of up to 400, is exceptional.

A low retention time is inherent in free-crushing machines. Little overgrinding takes place, and the production of excessive undersize material or "fines" is avoided. Protracted milling times are found with many slow-speed mills, with the result that considerable overgrinding takes place. Accumulation of product particles within the mill reduces the effectiveness of breaking stresses, and the efficiency of milling progressively decreases. This is typical of "open-circuit" grinding, in which the material is passed only once through the mill, remaining until virtually all has reached the required product size. An overall increase in efficiency is secured in "closed-circuit" grinding. Product particles are removed from the mill by means of a current of air or liquid or, alternatively, by screens. The removed product may then be classified and any oversize material returned to the mill. Adoption of closed-circuit grinding techniques is only possible on a relatively large scale. On a smaller scale, the effect can be simulated by periodic classification of the entire mill contents and the removal of material that has reached the required size.

## Dry and Wet Grinding

Between the approximate limits of 5% and 50% moisture, materials cake and do not flow. Both factors oppose effective grinding. Dry grinding is carried out at low moisture contents, the upper limit depending on the nature of the material. Although 5% or more moisture may be permissible for vegetable drugs, it would prove excessive during the milling of a coarse, impervious solid.

Wet grinding is a common procedure when a fluid suspension is required and drying, which would prove a significant drawback, is unnecessary. An excellent dispersion can be produced simultaneously, and in some operations, this provides the primary objective, size reduction being of secondary importance. Wet grinding may also be adopted when the size reduction achieved during dry grinding is prematurely limited by aggregation.

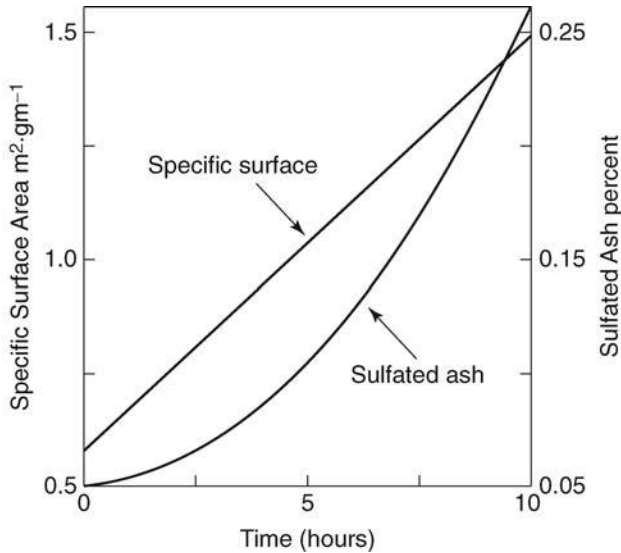

**FIGURE 12.2** Contamination of griseofulvin during milling.

Certain general advantages are secured during wet grinding. These include an increased mill capacity, a lower energy consumption, the elimination of hazards from dust, and easier handling of materials. The principal disadvantage, apart from the possible inclusion of a drying stage, is the increased wear of the grinding medium.

### Contamination

Wear of grinding elements, which occurs in all mills, results in the contamination of the product. This factor influences the choice of constructional materials, and ceramics and stainless steel are most commonly used. Contamination is normally slight. However, in the protracted periods often associated with the production of very fine powders, it may become severe. This is illustrated by the data presented in Figure 12.2, which shows a progressive increase in a sulfated ash value of the material due to wear of the ceramic mill.

Closed mills, preventing the ingress of bacteria, must be used for grinding sterile materials.

### Temperature Sensitivity

Care must be exercised during the milling of temperature-sensitive materials, especially when a very fine product is required. Caking results if the softening point is exceeded. Materials may be chilled before grinding, or facilities for cooling the mill during grinding may be provided. Waxy solids can be successfully ground with dry ice, the low temperatures conferring brittle characteristics on the material. Chemical degradation may occur at high grinding temperatures. Oxidative changes can be prevented by grinding in an inert atmosphere such as nitrogen.



### Structural Changes

Several examples of change of physical structure during very fine grinding have been reported. Gammage and Glasson found changes in the crystal form of calcium carbonate after ball milling (Gammage and Glasson, 1963). Distortion of the kaolinite lattice during very fine grinding was reported by Gregg (Gregg, 1955). Cleverley and Williams found that various barbiturate polymorphs were formed during grinding (Cleverley and Williams, 1959). Changes such as these could affect solubility and other physical characteristics, which, in turn, might influence formulation and therapeutic value.

### Dust Hazards

Hazards from dust may become acute during dry grinding. Extremely potent materials require dust-proofing of machines and the supply of dust-proof clothing and masks to operators. Danger may also arise from the explosive nature of many dusts.

## GRINDING EQUIPMENT

The following equipment is in regular use for dry grinding pharmaceutical materials: edge and end runner mills, hammer mill, pin mill, and ball mill.

The fluid energy mill is becoming widely used for the production of superfine powders. The ball mill and the colloid mill are used for wet grinding and the production of liquid dispersions. The end runner mill and adaptations of the roll mill may be used to comminute and disperse powders in semisolid bases, as, for example, in the production of ointments. These mills and the vibratory mill are described below.

### Edge and End Runner Mills

The edge runner mill consists of one or two heavy granite or cast iron wheels or mullers mounted on a horizontal shaft and standing in a heavy pan. Either the muller or the pan is driven. The material is fed into the center of the pan and is worked outward by the action of the muller. While in the zone traversed by the muller, comminution will occur by compression, due to the weight of the muller, and by shear. The origin of the shear forces is indicated in Figure 12.3A. The linear velocity of the pan surface will vary over the line of contact between muller and pan. For efficient grinding, this dimension is large compared with the diameter of the pan. Muller and pan speeds may only coincide on one hypothetical circle, and at other positions, a varying amount of slip must occur. A scraper continually moves material from the perimeter of the pan to the grinding zone.

The end runner mill is similar in principle and consists of a rotating pan or mortar made of cast iron or porcelain. A heavy pestle is mounted vertically within the pan in an off-center position. This arrangement is shown in Figure 12.3B. The mechanism of size reduction is compression due to the weight of the pestle, and shear. The latter is developed by the relative movement of muller and pan, which varies over the face of the muller. The muller is friction driven by the pan through the ground material. A scraper is used to redirect the material into the grinding zone.

Both mills operate at slow speeds on a packed bed. Both produce moderately fine powders and operate successfully with fibrous materials. Wet

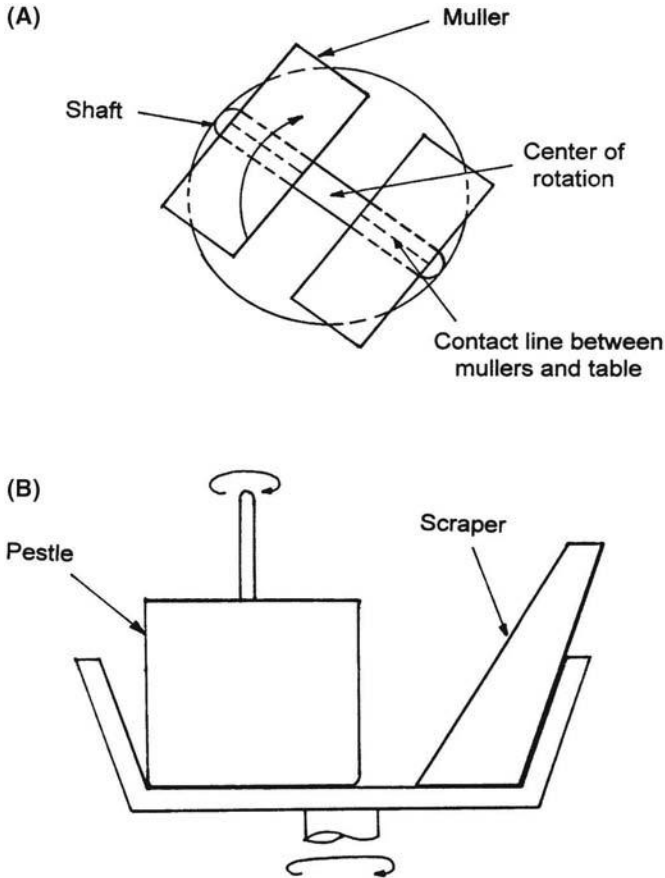

**FIGURE 12.3** (A) Edge runner mill and (B) end runner mill.

grinding with very viscous materials, such as ointments and pastes, is also possible.

### Hammer Mill

The hammer mill typifies a group of machines operating at very high speeds and acting primarily by impact on a freely suspended particle. The term “disintegrator” is also used. High efficiency, which would be expected from the operation of a free-crushing mechanism, is reduced because the blows delivered are in excess of the minimum required for breakage.

A typical machine is shown in Figure 12.4A. It consists of a disk rotating at speeds up to 8000 rpm. The higher speeds are used for fine grinding in relatively small machines. A balanced number of hammers are fitted to the disk. These may be fixed or pivoted, presenting flat, knife, or file edges to the material. The material is fed to the top or the center of the mill and is broken by direct impact until it is fine enough to pass through the screen, which forms the lower part of

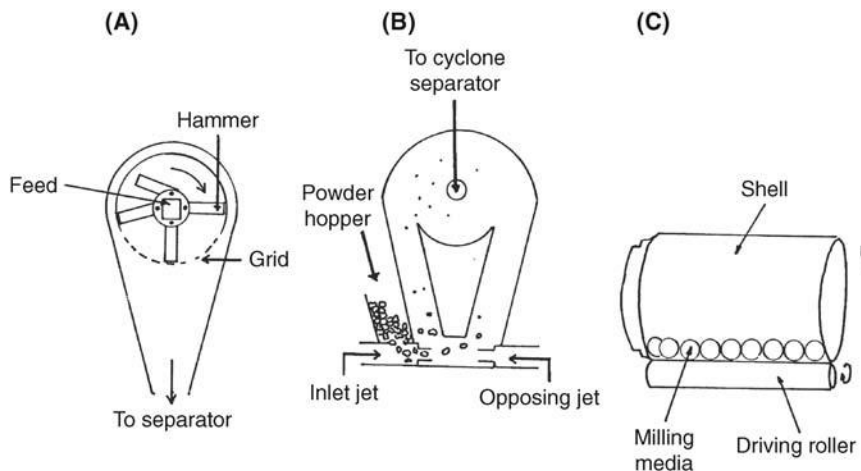

**FIGURE 12.4** (A) Impact mill with pivoted hammers, (B) comminution mill, and (C) ball mill.

the mill casing. A range of screens are normally provided. Because of tangential exit, the product size is considerably smaller than the screen apertures. The disk and hammers act as a centrifugal fan, drawing large volumes of air through the mill. Entrained dust must be separated with a bag filter or a cyclone separator.

The mill will process dry, crystalline materials, which do not soften under milling conditions, and many crude drugs. The speed of rotation and the size and shape of the screen apertures are interrelated factors controlling the size of the product. A considerable amount of very fine powder is produced. A marked rise in temperature can occur during passage through the mill, with consequent risk of fusion or decomposition of susceptible drugs.

Great versatility, derived from simple variation of screen, rotor speed, and type of blade, is characteristic of the refined mills commonly used in the pharmaceutical industry. The "Fitzmill" (The Fitzpatrick Company of America and Manesty Machines Limited) and the "Apex" comminuting mill (Apex Construction Company, London) are mobile machines constructed largely of stainless steel. The general principle is illustrated in Figure 12.4B. Both offer a large screen area and operate at various speeds. A reversible rotor permits the use of blades presenting either a flat, impact face or a cutting edge to the material. Materials are ground by high-speed operation of the impact face. The knife edges may be used at lower speeds for wet granulation and the precision reduction of the imperfect tablets produced during dry granulation. The mill may be jacketed to control milling temperatures. Mixing, wet grinding, and ointment milling may also be performed.

### Pin Mill

Pin mills consist of two horizontal steel plates with vertical projections arranged in concentric circles on opposing faces and becoming more closely spaced toward the periphery. The projections of the two faces intermesh. The material is

fed through the center of the stationary upper disk onto the lower revolving disk and is propelled by centrifugal action toward the periphery. The passage between the pins provides size reduction by impact and attrition. The material is collected in the annular space surrounding the disks and passes to a separator. The large volumes of air drawn through the mill are discharged through the separator. Absence of screens and gratings provides an action that is free from clogging. The machine is suitable for grinding soft, nonabrasive powders, and low milling temperatures permit the processing of heat-sensitive materials. The fineness of the grind may be varied by the use of disks with different dispositions of pins.

### **Ball Mill**

The ball mill is widely used for fine grinding. Extremely fine powders may be produced, although milling times are often protracted. Despite simple construction, the mill is extremely versatile. It can be used for wet or dry grinding in continuous or batch processes. The latter are usually imposed by the scale of pharmaceutical operations. The mill is closed. Sterility can therefore be maintained or an operation can be conducted in an inert atmosphere if the process demands such conditions. Materials of widely differing mechanical properties can be ground by the combined effects of impact and attrition characteristic of the mill.

The ball mill, in its simplest form, is illustrated in Figure 12.4C. It consists of a rotating, hollow cylinder containing balls usually made of stainless steel or stoneware. During grinding, the balls slowly wear and are eventually replaced. For general purposes, the mill will therefore contain balls of different sizes, which perform different functions. The loading of the mill varies. Typically, the mill is half filled with balls and the material to be ground is added to overfill the interstices between the balls. The apparent volume of the total charge is commonly 60% of the mill volume. In operation, the distance the charge moves up the mill casing depends on the centrifugal force. This is a function of the speed at which the mill rotates and the friction between charge and mill lining. These effects determine the pattern of movement within the mill. At low grinding speeds, the balls tumble, roll, and jump down the free face of the charge, a pattern described as "cascading." With increase in speed, the pattern progressively changes to "cataracting" in which the balls are carried almost to the top of the mill and fall directly onto the charge below.

The grinding contributions of impact and attrition vary in these patterns of movement. Attrition predominates in the cascading mill and depends, to some extent, on the surface area of the balls. The effect can therefore be enhanced by the use of small balls. Impact breaking becomes more important in the cataracting mill, the most effective action being derived from the high kinetic energy of the larger balls, a factor also influenced by the latter's density.

If there is sufficient friction between the mill lining and the charge, the latter will "key" to the mill at higher speeds and rotate with it. This is termed "centrifuging," and since there is no relative movement between the balls, no grinding occurs. The speed marking the onset of centrifuging is called the critical speed. Theoretically, it represents conditions for which the centrifugal and gravitational forces acting on a ball at the top of the mill are balanced. If the mass of the ball is  $m$ , the gravitational force is given by  $mg$  and the centrifugal

force is  $mv_c^2/r$ , where  $v_c$  is the critical speed and  $r$  is the distance of the ball from the axis of the mill, that is, the radius of the mill minus the radius of the ball. These may be equated to give

$$v_c = \sqrt{gr} \quad (12.4)$$

In practice, centrifuging does not occur until well above the theoretical critical speed, and it varies with mill loading and the amount of slip between charge and lining. Mills usually operate at between 50% and 80% of the critical speed. The lower speeds are used for wet grinding and very fine dry grinding.

If a low coefficient of friction permits extensive slipping between mill and charge, centrifuging will not occur even at very high mill speeds. Under these "supercritical" conditions, the grinding action differs from the pattern described above.

By correct choice of ball size, mill speed, and diameter, the ball mill may be used to grind material of widely different particle size. In coarse dry grinding, the energy is associated with the largest ball falling and the diameter of the mill must be sufficient to break the largest particle. Very fine grinding, on the other hand, is best effected by the attrition between a large number of small balls. The most important limiting factor in the production of very fine particles by milling is agglomeration. Ultimately, the reduction of new surface by rebonding may equal the increase in surface due to fracture. This is shown as point A in the relation of specific surface area and milling time given in Figure 12.5. With further grinding, the effective particle size may actually increase. Agglomeration during fine dry grinding is usually more severe than that in wet grinding. In both cases, however, additives can sometimes be used to limit its effect.

The ball mill also provides a simple mechanical means of producing dispersions of solids in liquids. Wet grinding depends on the attrition characteristic of the cascading mill. The smaller the balls, the greater the effect and the greater the viscosity of the suspension. The latter should not prevent the correct

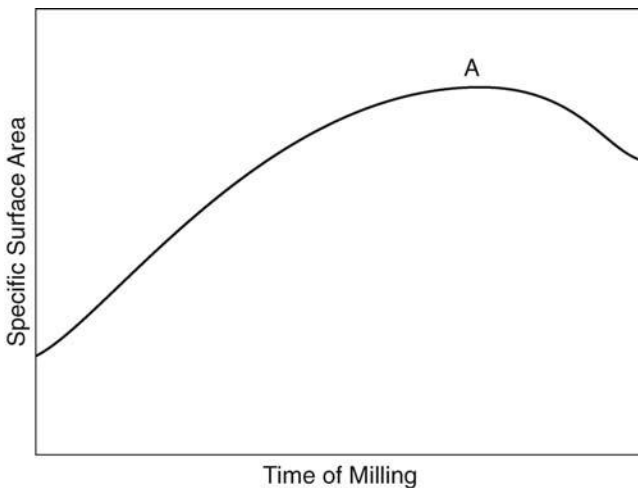

**FIGURE 12.5** The effect of particle agglomeration during milling.

movement of the charge. Where their use is permissible, the addition of surface-active agents may greatly accelerate the process by preventing reaggregation of the particles. Surface-active agents can also alter the physical properties of the solid, lowering the breaking strain and rendering the particle more brittle. A higher ratio of solids to liquid, which aids efficient milling, is possible if the system is deflocculated.

In large-scale, continuous installations, the mill may be modified to apply grinding forces appropriate to the size of particle being ground. In the tube mill, the ratio of length to diameter is greatly increased and the mill is divided into several compartments, each containing balls of different average size. The coarse material first enters the compartment containing the largest balls. It is then conveyed to successive compartments containing smaller balls and capable of progressively finer grinding. In the Hardinge conical ball mill, natural segregation is induced by the conical shape. The largest balls operate at the largest diameter and, through the kinetic energy acquired during the extensive fall, create high-impact stresses suitable for breaking coarse particles. The material first passes through this region. With further progress through the mill, the greater surface presented by the smaller balls promotes finer grinding by attrition.

### **Vibratory Mill**

In the ball mill, the energy for grinding is derived from the acceleration of the balls in a gravitational field. Under normal conditions, the latter limits the speed at which a mill of a given diameter can be run and therefore limits the rate at which energy can be applied to the process. Long milling times are characteristic of the ball mill. The advantage of vibratory milling is centered mainly on this limitation since it is possible, by this method, to develop accelerations much greater than those induced by the earth's gravitational field. Grinding can be more energetic, and milling times can be greatly reduced.

A simple form of vibratory mill consists of a mill body containing the grinding media, usually of porcelain or stainless steel balls. The mill body is supported on springs, which permit an oscillatory movement. This vibration is usually, but not necessarily, in a vertical plane. The suspended mass is maintained in a state of forced vibration by some means such as the rotation of a shaft on which unbalanced weights are mounted. The charge is subjected to movements of high frequency and small amplitude. The resultant chattering of the mill gives comminution by attrition. Characterized by relatively high-speed grinding, the mill is usually more flexible than the ball mill, charging and discharging and adaption to continuous processing being much easier. The more efficient use of the energy applied and the shorter grinding times usually result in lower milling temperatures than that found in a ball mill. Construction, however, is more complex, and the feed size of the material is limited to approximately 0.25 in. or less. The mill is not suitable for grinding resilient materials, which cannot be ground by impact since the shear forces developed are less than those found in a ball mill.

A refined example of this principle is found in the Podmore-Boulton vibro-energy mill, shown in Figure 12.6A. This consists of an annular grinding chamber generally accommodating a medium of small cylinders. These align coaxially in a three-dimensional vibratory field to give close packing and line

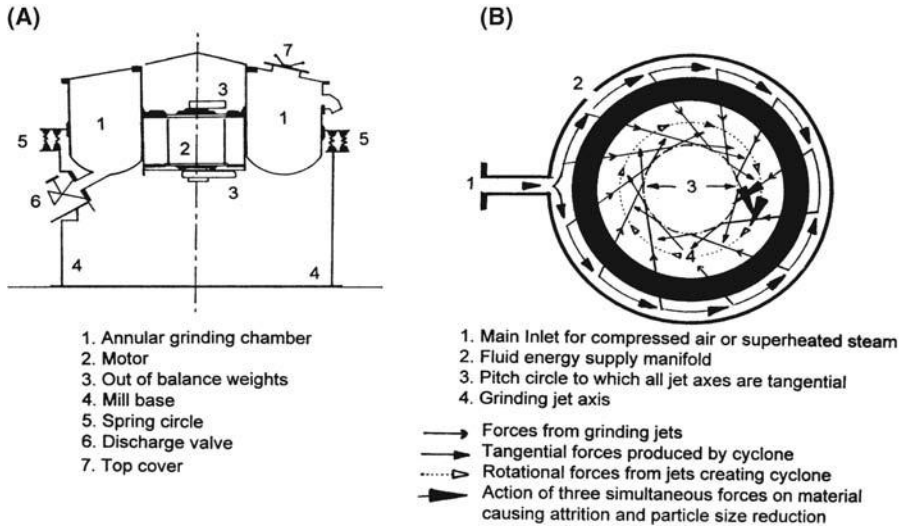

**FIGURE 12.6** Diagrams of (A) vibro-energy mill and (B) fluid energy mill.

contact between moving surfaces. This, it is claimed, gives preferential grinding of coarse material, leading to products with narrow particle size distributions.

**Fluid Energy Mill**

The fluid energy mill offers an alternative method of producing very fine powders. The term “micronizer” is in general use and is a trade name coined by a company that originated a particular type of fluid energy mill. In all fluid energy mills, the grinding results mainly from attrition between the particles being ground, the energy inducing movement of the particles being supplied in the form of compressed fluids. Air and steam are widely used.

A common type of fluid energy mill is illustrated in Figure 12.6B. The material is blown into the grinding chamber through a venturi feed placed at its perimeter. The compressed fluid enters the chamber through nozzles tangential to a hypothetical circle within the grinding chamber. The particles are violently accelerated by the rotating fluids and are subjected to the influence of successive nozzles. Grinding results from impact between particles, which are then subjected to the intense classifying action of the circulating fluid. Oversize particles remain in the grinding zone, while fine powder and spent grinding fluid spiral to the central outlet.

For a given machine, the size reduction depends on the size of the feed, its rate of introduction to the grinding chamber, and the pressure of the grinding fluid. The most important machine factors are the geometry of the grinding chamber and the number and angle of the nozzles.

Powders with all particles below a few microns may be quickly produced by this method. The disadvantage of high capital and running costs may not be so serious in the pharmaceutical industry because of the high value of the materials that are often processed. For grinding drugs, the mill is usually made

of stainless steel. Large volumes of air compressed to about  $6.89 \times 10^5 \text{ N/m}^2$  must be provided.

### **Colloid Mills**

Colloid mills are a group of machines used for wet grinding and dispersion. They operate by shearing relatively thin layers of material between two surfaces, one of which is moving at a high angular velocity relative to the other. Although very fine dispersions can be produced, they are not, as the name implies, of colloidal dimensions. Colloid mills are also widely used in the preparation of emulsions.

A typical colloid mill consists of a stator and a rotor with flat working surfaces. These are often made of stainless steel or carborundum. The clearance is adjustable from virtually zero upward. The rotor is rotated at several thousand revolutions per minute, and the slurry of already fine material passes through the clearance under the action of centrifugal forces. Surface-active agents fulfill the same function in colloid mills as in ball milling.

### **Roller Mills**

Roller mills may be used to grind pastes and other plastic dispersions. They operate by inducing crushing and shearing forces in a thin layer of the paste as it passes through the narrow clearance between two rollers. Commonly, shear forces are intensified by the differing peripheral velocity of the rolls. The clearance between the rolls is variable and depends on the plasticity of the mass, the gap increasing as the stiffness of the material increases. With thin pastes, the milling action is similar to the colloid mill.

## **CLASSIFICATION OR SIZE SEPARATION**

In the introduction to this chapter, the influence of particle size on several processes was described. The operation in which particles of a suitable size are selected and others rejected because they are too small or too large is called classification or size separation. This process is also important in closed-circuit grinding, removal of fine powders to promote flow, and restriction of particle size distribution to prevent segregation or to enhance appearance.

Although a number of particle properties can be used to classify a powder, only two are important. The first is based on the ability of a particle to pass through an aperture. This is sieving or screening. The second employs the drag forces on a particle moving through a fluid. The term classification is sometimes restricted to this method of separation, but in this text elutriation and sedimentation will be used. In general, screening is applied to the separation of coarse particles, and elutriation and sedimentation to fine particles.

### **Sieving and Screening**

Sieves and screens are widely used for the classification of relatively coarse materials. For very large particles, greater than half an inch, a robust plate perforated with holes is used. However, the pharmaceutical applications of screening are with much smaller particles, and screens are in the form of woven meshes. Unless special methods are used to prevent clogging and powder aggregation, the lower useful limit resides in a cloth woven with 7900 meshes/m.



This corresponds to a mesh spacing of between  $7.0 \times 10^{-5}$  and  $8.0 \times 10^{-5}$   $\mu\text{m}$ . Fine screens of this type are extremely fragile and must be used with great care.

A series of suitable sieve cloths is described in the Fine Mesh series of British Standard (BS) 410:1962. This specifies the gauge of the wire and the permitted weaving tolerances. In successive meshes of this series, the mesh space alters by a factor of  $4\sqrt{2}$ . In the mesh series commonly chosen for size analysis, 16-22-30-44-60-85-120-170, alternate screens are selected so that the mesh spacing decreases by  $\sqrt{2}$  and the area of the apertures is halved. For classification, one or more meshes of suitable weave can be chosen from this series and mounted in a frame.

In operation, the mesh should be lightly loaded so that all particles capable of passing the mesh (undersize) have a chance to do so. The mesh must, therefore, be agitated both to ensure access of particles to the holes and to clear holes blocked by particles just unable to pass. Under these conditions, the rate of sieving is proportional to the number of undersize particles on the screen. It therefore decreases exponentially.

Most screening, particularly that of coarse materials, is carried out dry. The wet screening of dilute slurries is adopted for powders that aggregate strongly, clog the mesh, or become electrostatically charged by the vibrations of the screen. Sieving errors arising from the cohesion of small and large particles and the retention of the former on a coarse mesh are avoided. Wet screening is particularly useful if the subsequent process is wet and drying is unnecessary.

For small-scale classification, test sieves with meshes conforming to BS 410 can be used. The mesh is mounted on a circular brass frame, 8, 12, or 18 in. in diameter, a rim on the lower edge enabling it to "nest" with the sieve below. When the chosen sieves are equipped with a lid and a receiving pan, the agitated assembly becomes an effective small-scale grading unit. Sieving is stopped when the rate at which particles pass the mesh has reached some low value or after some predetermined time at which the rate is known to be low.

As the scale of the operation increases, it becomes, in general, less precise. For continuous screening, the feed material is made to move across the screen to a point of discharge. The residence time on the screen is usually short, and many undersize particles traverse it without falling through. With increase of sieving area, the meshes become more fragile and the finest meshes must be supported with a coarser wire. An example of a large-scale separator utilizes a circular screen of up to 5 ft in diameter and is vibrated in a horizontal plane, the gyratory movement being imparted by an out-of-balance fly wheel connected to the assembly. In other machines, the mesh is rectangular and inclined at a shallow angle ( $5^{\circ}$ – $30^{\circ}$ ). A gyratory movement is developed, and the material to be classified is fed to the top end. These machines may bear more than one deck, thus allowing the separation of the powder into several fractions at one time.

### **Elutriation and Sedimentation**

The balance of the drag force on the particle and the forces promoting movement occurs at the terminal velocity. This velocity depends, among other things, on the size of the particle, and it is the property on which several classifiers are based. The fluid is either air or a liquid. The latter affords a higher precision because dispersion can be more thorough. High shear forces cannot be developed and dispersing agents cannot be used in air.

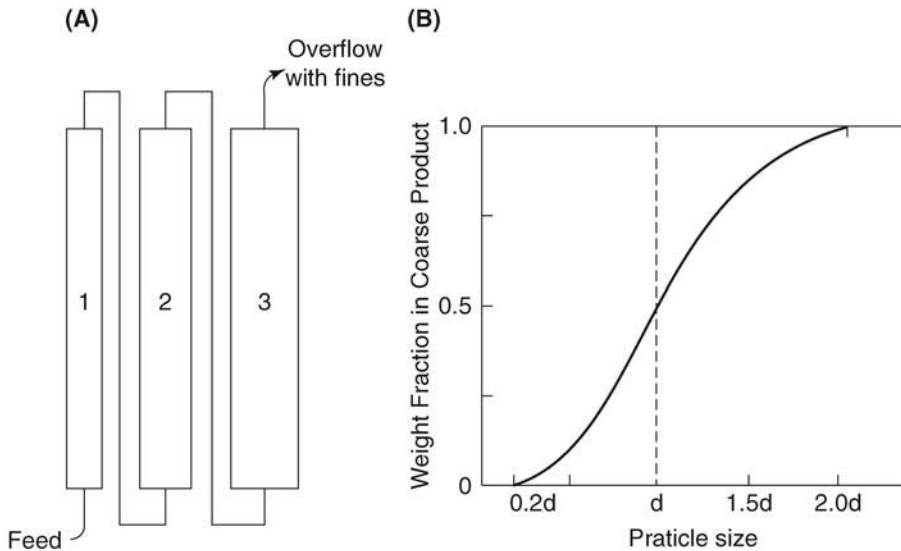

**FIGURE 12.7** (A) An elutriator and (B) grade efficiency curve.

The simplest classifier is a rising current of fluid in which the particles are suspended. In this case, the force opposing the upward drag is gravitational. If the opposition gives a terminal velocity greater than the current speed, the particle will fall. This is the principle of elutriation, and the particle size,  $d$ , at which the separation is made follows from a rearrangement of equation (2.24) in chapter 2 for conditions in which Stokes' law is valid.

$$d = \sqrt{\frac{18\eta\mu}{(\rho_s - \rho)g}} \quad (12.5)$$

where  $\rho_s - \rho$  is the density difference between solid and fluid,  $\eta$  is the viscosity of the fluid, and  $\mu$  is the speed of the upward current.

The elutriator shown in Figure 12.7A consists of three tubes. The first is smallest in diameter and offers the highest upward liquid velocity. Coarse particles with a high terminal velocity settle in this tube, while the remainder are swept to the bottom of the second. The diameter of the second tube exceeds that of the first, and elutriation speeds are lower. Only fine particles are swept into the third tube where the process is repeated at a finer size. In this way, the original slurry is divided into four fractions.

In practice, fluctuations in flow conditions due to natural convection and a violation of the conditions for which Stokes' law is valid blur the point of separation. The evaluation of the separation must, therefore, take account of the fine particles that fall with the coarse particles and the coarse particles that move to the fine fraction. This is best expressed by a grade efficiency curve. Returning to equation (24) in chapter 2, a particle of size  $d$  should be stationary in the elutriation tube. Because of fluctuating conditions, it eventually resides with either

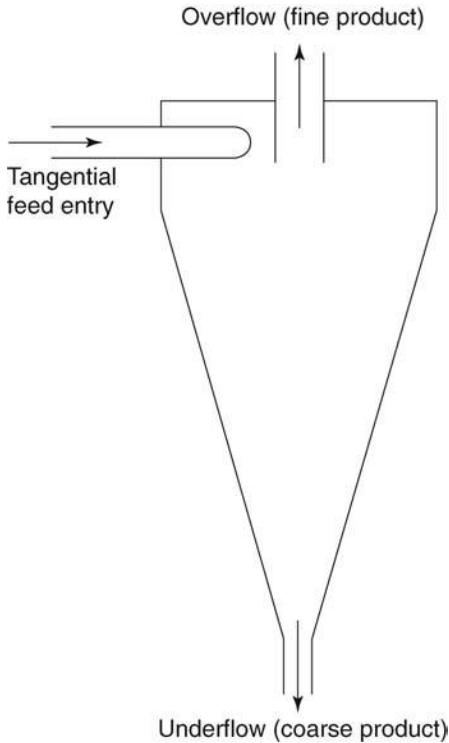

**FIGURE 12.8** Cyclone separator.

the coarse or the fine fractions, the chances being equal. The weight fraction in each is, therefore, 0.5 at this particular size. We shall assume that of the particles that are twice this size ( $2d$ ), virtually all appear in the coarse product.

The weight fraction here is 1. Similarly, all particles of size  $0.2d$  move to the fine product so that the weight fraction in the coarse product is 0. As shown in Figure 12.7B, a sigmoid curve, passing through 0.5 at size  $d$ , links these extremes. The closer these extremes and the steeper the curve, the more efficient the separation. A grade efficiency curve of this type can be used as an appraisal of any sedimentor or elutriator.

Gravitational sedimentation is not of great importance in small-scale classification. Sedimentation in a spinning fluid stream is, however, widely used. The most common classifier of this type is the cyclone separator shown in Figure 12.8. The fluid enters tangentially and acquires an intense spinning motion, spiraling downward into the cone before rising to the outlet as a central core. The inlet speed is very high so that large angular velocities are developed. Because of centrifugal force, particles move radially across the spinning stream to fall at the wall into the cone. Operated in this way, complete separation of solids occurs, and the cyclone is, therefore, an effective air cleaner. Operated with lower centrifugal forces, the cyclone transports the finest particles to the exhaust, leaving the coarser particles to fall into the cone. Cyclone classifiers are designed for use with either liquid or air.

The centrifuge is normally operated to completely separate two phases. If, however, the rate at which the feed passes through does not allow all particles to settle, the action of a classifier is developed. This is illustrated by a solid bowl centrifuge, which consists of a steel shell in the form of a frustrum mounted horizontally. It contains a conveying screw at the wall, which rotates at a slightly higher speed than the shell. Particles that settle at the wall are conveyed to the narrow end of the shell and discharged. Fine particles are entrained with the overflow to the other end. Further details of this and other centrifugal classifiers have been given by Treasure (Treasure, 1965).

### INTRODUCTION

Mixing has been defined as an operation “in which two or more ingredients in separate or roughly mixed condition are treated so that each particle of any one ingredient is as nearly as possible adjacent to a particle of each of the other ingredients.” (Perry and Chilton, 1999) The term “blending” is synonymous, and “segregation” or “demixing” is the opposite.

Mixing is a basic step in most process sequences, and it is normally carried out

1. to secure uniformity of composition, so that small samples withdrawn from a bulk material represent the overall composition of the mixture and
2. to promote physical or chemical reactions, such as dissolution, in which natural diffusion is supplemented by agitation.

Dankwerts (Dankwerts, 1953) classified mixing as follows:

*Positive mixing*, which applies to systems that, given time, would spontaneously and completely mix. Examples are provided by two gases or two miscible liquids, and mixing apparatus is used on such systems to accelerate mixing.

*Negative mixing*, which is demonstrated by suspensions of solids in liquids. Any two-phase system, in which the phases differ in density, will separate unless continuously agitated.

*Neutral mixing*, which occurs when neither mixing nor demixing takes place unless the system is acted upon by a system of forces. Examples are found in the mixing of solids and of solids with liquids when the concentration of the former is high.

Mixing must embrace all combinations of the three states of matter. The theory of mixing should be able, when the system to be mixed has been defined, to dictate the type and design of the mixer, such as volume, shape and type of impeller, and the process conditions, such as degree of agitation, and the time and power required. Theoretical knowledge is, however, insufficient to predict the performance of mixers. More commonly, choice is based on broad empirical principles, which are then supported by practical tests.

### THE SCALE OF SCRUTINY

Whether or not materials are satisfactorily mixed depends on the subsequent operations in which the mixture plays a part. Any mixture, if examined on a small-enough scale, will show regions of segregation. An acceptable degree of mixing is related to subsequent operations in a process sequence. Dankwerts introduced the term “scale of scrutiny” to describe the minimum size of the regions of segregation in a particular mixture, which would cause it to be regarded as insufficiently mixed (Dankwerts, 1953). For example, if a tablet is to contain 0.1 g of drug A and 0.1 g of drug B, the powder from which the tablets

are to be made must be sufficiently mixed so that on drawing a sample of 0.2 g from the mixture, the sample will contain, within narrow limits, the correct amounts of A and B. The way in which A and B are dispersed within the sample may be of no importance so long as the tablet is not divided. The scale of scrutiny is here determined by the weight of the tablet.

In general, a small scale of scrutiny is applied if the unit size of the product is small and if too much or too little of one component is very undesirable.

Two further useful concepts may be introduced here to describe unmixedness: the scale of segregation and the intensity of segregation. The scale of segregation is a measure of the size of the regions of unmixed materials. In the example given above, the intensity of segregation shows the extent to which A has been diluted with B and vice versa. These two concepts are usually inter-related. A high intensity of segregation can be tolerated so long as the scale of segregation is small. Alternatively, a larger scale of segregation may be tolerated if the intensity of segregation is reduced.

### THE MIXING OF SOLIDS

Pharmacy offers many important examples of the mixing of solids. In several forms of drug presentation, the attainment of accurate dosage depends on an adequate mixing operation at some stage in production. Since the dose unit may be small, say 0.1 g, a small scale of scrutiny is applied.

The mixing of all systems of matter involves a relative displacement of the particles, whether they are molecules, globules, or small crystals, until a state of maximum disorder is created and a completely random arrangement is achieved. Such an arrangement for a mixture of equal parts of two components is shown in Figure 13.1B.

A "perfect" mixture, which, with a practical sample, would offer point uniformity, is shown in Figure 13.1A. Such an arrangement is, however, virtually impossible, and no mixing equipment can do better than producing the "random" mixture shown in Figure 13.1B. In such a mixture, the probability of finding one type of particle at any point in the mixture is equal to the proportion of that type of particle in the mixture.

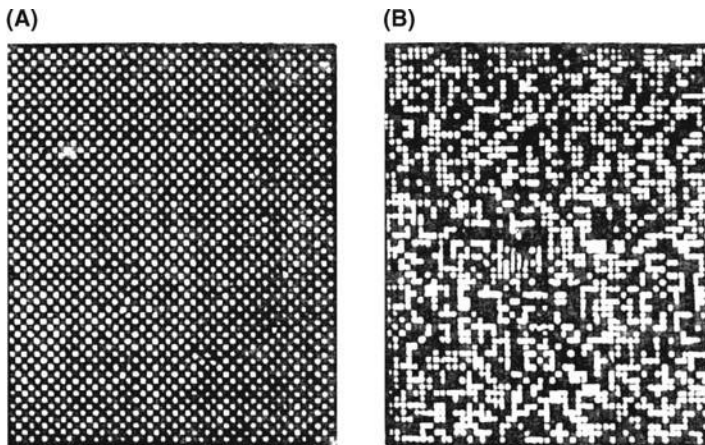

FIGURE 13.1 Diagrammatic representation of (A) a perfect mix and (B) a random mix.

The mixing of solids differs from the mixing of liquids in that the smallest practical sample withdrawn from a mixture of two miscible liquids contains many millions of *particles*. In the mixing of solids, a small sample contains relatively few particles, and examination of Figure 13.1B should show that such samples will show considerable variation with respect to the overall composition of the mixture and that this variation should be reduced as the number of particles in the sample is increased. Assessing the variation in, say, drug content in a series of samples drawn from a mixture of powders is of great importance. The tablet machine may be regarded as a volumetric sampling device, and the variation in drug content between one tablet and the next is largely controlled by the mixing stage that precedes it.

### Some Properties of a Random Mixture

"Lacey, 1953" showed that the variation in the composition of samples drawn from a random mixture of two materials could be expressed by the following relation:

$$s = \sqrt{\frac{p(1-p)}{n}} \quad (13.1)$$

where  $s$  is the standard deviation of the samples,  $p$  is the proportion of one component, and  $n$  is the number of particles in the sample. The relation requires that the two components are alike in particle size, shape, and density and can only be distinguished by some neutral property, such as color. If a very large number of samples, each containing a given number of particles, are withdrawn from a mixture of equal parts of two materials, the results of analysis can be presented in the form of a frequency curve in which the samples are normally distributed around the mean content of the mixture; 99.7% of the samples will fall within the limits  $p = 0.5 \pm 3\sigma$ . The standard deviation of the samples is inversely proportional to the square root of the number of particles in a sample. If the particle size is reduced so that the same weight of sample contains four times as many particles, the standard deviation will be halved. The distribution of samples and the effect of size reduction are shown in Figure 13.2.

In a critical examination of pharmaceutical mixing, Train showed that samples of a random mixture of equal parts of A and B must contain at least 800 particles if 997 out of every 1000 samples ( $3\sigma$ ) were to lie between  $\pm 10\%$  of the stated composition, that is, the proportion,  $p$ , of A =  $0.5 \pm 0.05$ , where  $\sigma = 0.05/3$  (Train, 1960). The effect of the number of particles in a sample on the percentage variation about the mean content of a mixture of equal parts A and B was summarized by Train in the diagram reproduced in Figure 13.3. The diagram may be used to show that if, in the above example, limits of  $\pm 1\%$  were substituted, 90,000 particles must be present in each sample. The true standard deviation is given by the symbol  $\sigma$ . The standard deviation estimated by the withdrawal of a number of samples is denoted  $s$ .

If, instead of equal parts A and B, the proportion of an active ingredient, A, in the mixture was 0.1 (10%), imposition of limits of  $\pm 10\%$  (in 997 out of 1000 cases) requires that each sample shall contain over 8000 particles. If the proportion of active constituent is 0.01, or 1%, a figure of 90,000 particles per sample is obtained, and if the limits are reduced to  $\pm 1\%$ , the active constituent is 0.01, or 1%, a figure of 90,000 particles per sample is obtained, and if the limits are reduced to  $\pm 1\%$ , the figure is nine million.

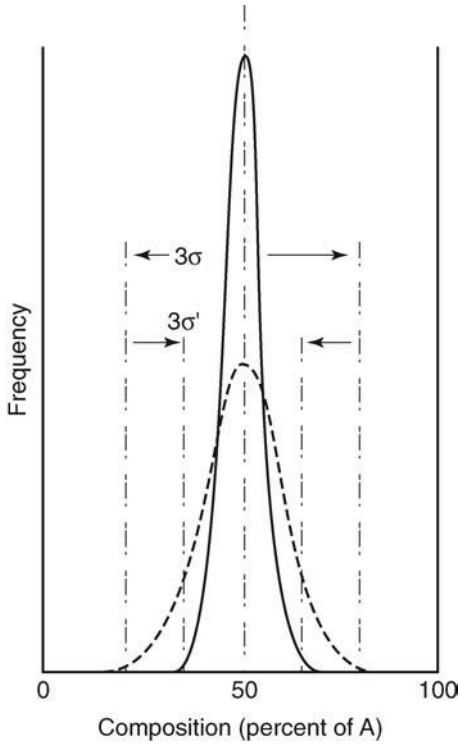

**FIGURE 13.2** Distribution of samples drawn from a mixture of equal parts A and B. The broken line represents data for the coarser powder.

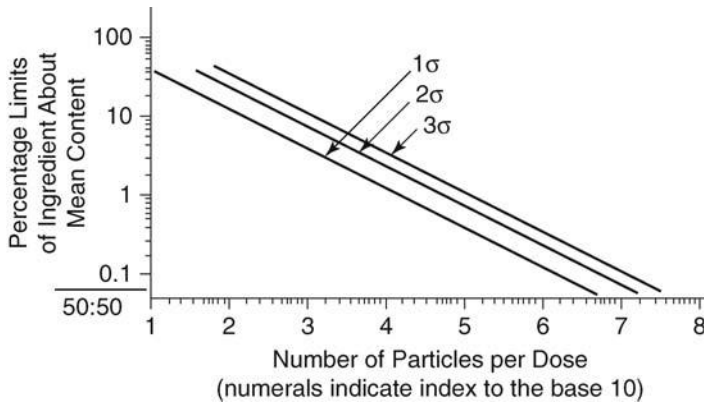

**FIGURE 13.3** General theoretical relationship between number of particles and percentage limit of ingredient for a 50:50 mix.

The theoretical derivation of these results is based on component particles that are alike in size, shape, and density. This condition is not encountered in the practical mixing of solids, and, as we shall see later, any of these factors may prevent the formation of a random mixture. The value of the number of particles per sample derived in any example must therefore be raised if the limits given are to be maintained.



As the proportion of an active ingredient in a mixture decreases, the number of particles in each sample or dose must increase, and materials of smaller particle size must be used. This statement indicates the limitation of the mixing of solids. Production of very fine powders is difficult and often attended by severe aggregation, thus defeating the object of size reduction in the mixing process. Where the proportion of active constituent is very small and is finally presented in a small dose unit, dry mixing of solids may fail to produce an adequate dispersion of one component in another and other methods, such as spraying a solution of one component onto another, must then be adopted.

Another example of the relation of dose uniformity and number of particles in the dose is found with two components that are separately granulated before mixing. This procedure is sometimes adopted for reasons of stability during granulation. The variation in samples drawn from such a system will be much greater than the variations in a mixture that was mixed before granulation because the effective number of particles in the sample is greatly reduced.

### The Degree of Mixing

A quantitative expression that defines the state of a mix is necessary if a rational answer to the question "Is this material well enough mixed?" is to be made. Such an expression would also allow the course of mixing to be followed and the performance of different mixers to be compared. The most useful method of expressing the degree of mixing is by measuring the statistical variation in composition of a number of samples drawn from the mix. The scale of scrutiny determines the size of the samples, and their number depends on the accuracy required of the assessment.

As already shown, a series of samples drawn from a random mix exhibit a standard deviation of  $s_r$ . An index of mixing,  $M$ , suggested by Lacey, is given by

$$M = \frac{s_r}{s} \quad (13.2)$$

where  $s$  is the standard deviation of samples drawn from the mixture under examination (Lacey, 1954). This approaches unity as mixing is completed. Kramers has suggested that

$$M' = \frac{s_o - s}{s_o^2 - s_r} \quad (13.3)$$

where  $s_o$  is the standard deviation of samples drawn from the unmixed materials (Shotton and Ridgway, 1974). It is equal to  $p(1 - p)$ , where  $p$  is the proportion of the component in the mix. Its modification by Lacey, using the variance of the samples, to

$$M'' = \frac{s^2 - s_r^2}{s_o^2 - s_r^2} \quad (13.4)$$

gives a fundamental equation for expressing the state of the mixture, the index,  $M''$ , varying from 0 to 1 (Lacey, 1954).

The binomial and Poisson distributions have also been used to examine the state of a mixture. If the proportion of black particles in a random mixture of

black and white particles is  $p$ , the probability,  $P(x)$ , of obtaining  $x$  black particles in a sample of  $n$  particles is given by

$$P(x) = \binom{n}{x} p^x (1-p)^{n-x} \quad (13.5)$$

If  $p$  is small ( $<0.15$ ) and  $n$  is large, the Poisson distribution can be used, when

$$P(x) = e^{-m(m^x/x!)} \quad (13.6)$$

where  $m = np$ , the mean number of black particles in the samples of  $n$  particles. This relation may be used in an assessment of dry mixing equipment (Adams and Baker, 1956).

If  $m$  is greater than 20 and more than 10 samples are taken, then

1. about 10 of the samples will have the number of black particles outside the limits  $(m \pm 1.7\sqrt{m})$ ,
2. about 5% of the samples will have the number of black particles outside the limits  $(m \pm 2.0\sqrt{m})$ , and
3. about 1% of the samples will have the number of black particles outside the limits  $(m \pm 2.6\sqrt{m})$ .

Results of such tests in which small cubes of polythene were mixed in a double-cone blender are shown in Figure 13.4A and B. The probability that the results plotted in Figure 13.4A came from a random mixture is less than 0.01, 19 out of 34 samples exceeding the 1 in 10 limits. The densities of the two components in this example were 0.92 and 1.2. The results given in Figure 13.4B were obtained when the components were of the same density and the probability that the samples were drawn from a random mixture was 0.7.

Alternatively, satisfactory mixing may be established by imposing standards dictated by the operations in which the mixture is to take part. For example, Kaufman measured the variance of 10 samples drawn at random from a mixture of procaine penicillin and dihydrostreptomycin being mixed in a tumbler blender (Kaufman, 1962). The variance of the samples at different times during mixing is shown in Figure 13.5. The samples, which, in this case, weighed 5 g, represent the ultimate subdivision of a production-size antibiotic mixture. An acceptable degree

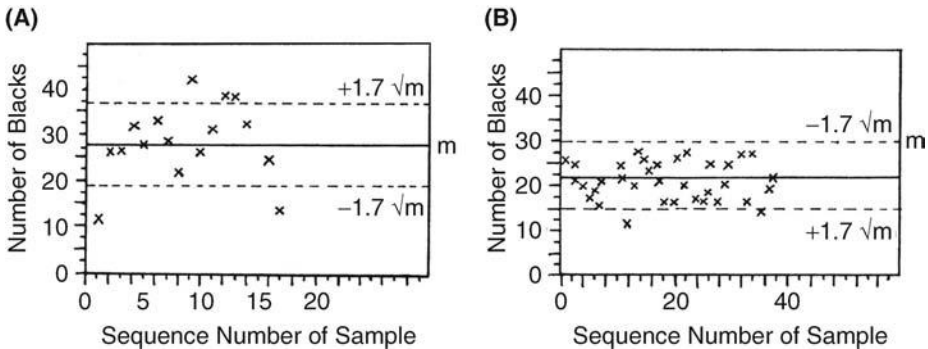

**FIGURE 13.4** Variation in the number of black particles in samples drawn from a tumbler blender. (A)  $p < 0.01$  and (B)  $p = 0.7$ .

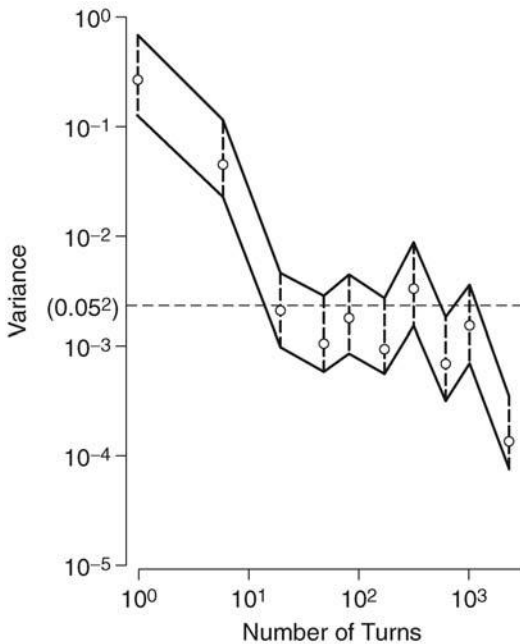

**FIGURE 13.5** Decrease in the variance of samples drawn from a mixture of penicillin (40%) and dihydrostreptomycin in a twin-shell blender.

of homogeneity was set at a standard deviation of 5%, giving a variance of  $(0.05)^2$ , and this was achieved after just over 100 revolutions of the mixer. [The band around the experimental values of the variance defines the limits within which the true variance lies ( $p = 0.9$ )]. By this method, the suitability of the machine and operating characteristics were established.

### The Mechanism of Mixing and Demixing

The randomization of particles by relative movement, one to another, is achieved by the following mechanisms:

*Convective mixing:* The transfer of groups of adjacent particles from one location in the mass to another.

*Diffusive mixing:* The distribution of particles over a freshly developing surface.

*Shear mixing:* The setting up of slip planes within the mass.

All take place to some extent during mixing, but they vary in extent with the type of mixer used. In general, a large diffusional element is necessary if the scale of scrutiny is small. In addition, distortion of portions of the material by intense shear forces, as in mulling, and the scattering of individual particles by impact, processes normally associated with size reduction, are used for some mixing operations.

Convective mixing predominates in machines utilizing a mixing element moving in a stationary container. An example is the horizontal ribbon mixer. Groups of adjacent particles are moved from one position to another, giving a steady decrease in the scale of segregation.

Shear mixing occurs when a system of forces acting on the particles induce the formation of a slip plane. This gives relative displacement of two regions. It

occurs, for example, in the rearrangement of shape as the main charge falls from end to end in a double-cone mixer. Train has stressed the importance of expansion or dilation of the material so that shear forces may be effective (Train, 1960). A practical corollary is that efficiency will be reduced if the machine is overfilled.

Diffusive mixing predominates in tumbler mixers. Tumbling occurs as the material is lifted past its angle of repose. Mixing occurs when a particle changes its path of circulation through a collision or by being trapped in voids presented by another layer of particles.

The mild forces involved in the examples given above may be insufficient to adequately disperse materials that tend to aggregate. The more energetic processes of mulling and impact milling may then be used. Size reduction and mixing are carried out simultaneously, although the former may be slight. An example is found in the incorporation of ferric oxide and basic zinc carbonate in the production of calamine. For mixing of this type, the hammer mills, mullers, and ball mills charged with small balls are frequently used. The material being processed at any time must contain the correct amounts of materials. If the holdup capacity of the mill is sufficiently large, this can be achieved by a correctly proportioned feed. Otherwise, the product will have to be mixed a second time by some other method to correct segregation of large scale but small intensity.

If all the particles in a mixture reacted equally to an applied force, then all mixers would eventually produce a random mixture, although the time taken would vary, the more efficient mixer producing a random mix more quickly. The characteristics of real mixtures prevent this, and differences in particle size, shape, and density oppose randomization. Of these, differences in particle size are most important. The role of these factors in opposing mixing and promoting demixing is demonstrated in the analysis of horizontal drum mixing (Donald and Roseman, 1962). Movement of material in a radial plane is shown in Figure 13.6. The static mass of particles is lifted past its angle of repose, and particles tumble down the free surface, accelerating to the center of the mixer and then decelerating before entering the static bed. The zone in which this takes place is the mixing zone, and since it is in contact with the static bed, in which no mixing takes place and which is moving in the opposite direction, a velocity gradient occurs across the mixing zone, that is, a layer of particles is passing over the layer beneath, and so on. This zone is in an expanded state, and particles are

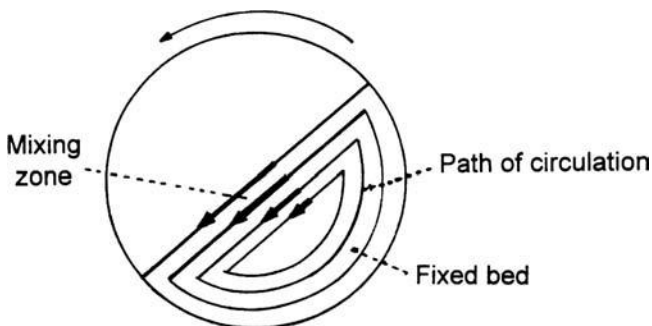

**FIGURE 13.6** The mechanism of radial mixing and demixing.

therefore passing over voids in the layer beneath. Mixing occurs when a particle is trapped by moving into a void, thus changing its path of circulation. This mechanism suggests an optimum running speed. If it is too slow, not enough events occur. If it is too fast, there is not sufficient time for capture.

As long as one type of particle is not preferentially caught, a random mix will eventually occur in the radial plane. If, however, one component is smaller or denser or has certain shape characteristics, it will be preferentially trapped and will move into the lower layers of the mixing zone until it finally concentrates as a central core running the length of the mixer. Similar effects occur in axial mixing, and the final shape of the segregated zone formed under the influence of axial and radial movements depends on the flow properties of the material. Similar effects have been reported with a double-cone blender (Adams and Baker, 1956). Segregation will also occur with such materials when they are dumped from the mixer.

In general, one component will concentrate at one position in the mixer when a simple, repetitive, and symmetric movement occurs. Modern design tends to the rotation of asymmetric shapes or to symmetric shapes rotated asymmetrically, often with an abrupt reversal in the movement of the charge. Even so, segregation may still occur after a long period of mixing. The variance of samples decreases during mixing to a minimum value. This is followed by a period of demixing, the variance finally achieving a higher equilibrium value. It is therefore possible to overmix.

### The Rate of Mixing

Since mixing is a process of achieving uniform randomness, the rate of mixing is proportional to the amount of mixing still to be done. If, at the start of mixing, a particle changes its path of circulation, it is most likely to find itself in a different environment. The rate of mixing is therefore fast. At the end of the process, the particle is less likely to find a different environment, and such a change gives no useful mixing. Fewer mixing events will take place, and the rate of mixing finally reaches zero. The rate of mixing for any mixing mechanism can be represented by the following expression:

$$\frac{dM}{dt} = k(1 - M) \quad (13.7)$$

where  $M$ , the index of mixing, has already been defined. Integration of this equation gives

$$M = 1 - e^{-kt} \quad (13.8)$$

The rate constant,  $k$ , depends on the physical nature of the materials being mixed and on the geometry and operation of the mixer.

## MIXING MACHINES

### Trough, Ribbon, and Paddle Mixers

A simple trough mixer consists of a semicircular trough in which an impeller, such as a number of paddles mounted at diverse angles on a shaft running the length of the trough, rotates, lifting and distributing the material in an irregular manner. Convective and shear mixing occur. Some fine-scale diffusive mixing occurs when the impeller lifts material clear of the main charge.

The ribbon mixer employs a ribbon-like conveying scroll. The helix, which may be continuous or interrupted, is rotated in a semicircular trough, and mixing again occurs through convection and shear, giving rapid coarse-scale dispersion. Two ribbons set to convey material in opposite directions are frequently fitted to the shaft. Although little axial mixing in the vicinity of the shaft occurs, mixtures with high homogeneity can be produced by prolonged mixing even when components differ in particle size, shape, or density or there is some tendency to aggregate.

### **Tumbler Mixers**

Tumbler mixers operate by a mainly diffusive mechanism, and their use is confined to free-flowing and granular materials. The mild forces employed, which preclude the mixing of materials that aggregate strongly, allows friable materials to be handled satisfactorily. The more elaborate geometrical forms are most commonly used because movement of material in all planes, which is necessary for rapid overall mixing, is induced. Internal baffles and lifter blades may also be incorporated. For example, axial movement of material along the length of a simple drum mixer is slow and can be enhanced by these methods.

### **Mullers and Impact Millers**

The function of machines of this type in mixing was discussed earlier in the chapter.

## **THE MIXING OF LIQUIDS**

In the mixing of miscible liquids, any practical scale of scrutiny embraces a very large number of particles. If, therefore, a mixture of liquids is randomized by agitation, for all practical purposes, it can be regarded as uniform. Miscible liquids are classified as positive mixtures and would, given time, mix completely without external help. The time required for mixing is reduced by agitation during which the scale of segregation is reduced, allowing a fast decay in the intensity of segregation by natural diffusion. In general, no great problems are encountered unless the scale of the operation is very large.

Miscible liquids are most commonly mixed by impellers rotating in tanks. These are classified as

1. paddles,
2. propellers, and
3. turbines.

In conjunction with the design of the containing vessel, these provide

1. a region of intense shear in the vicinity of the impeller with the induction of high-velocity gradients and turbulence within the liquid and
2. the projection of the disturbance as a flow pattern extending throughout the volume of the container. This is dictated by the type and position of the impeller, the design of the tank, and the flow properties of the material.

All the material should pass through the impeller zone at frequent intervals of time, the design of the mixer preventing the formation of "dead" zones. The turbulent, high-velocity flow of liquid from the impeller causes mixing by projecting eddies into and entraining liquid from the neighboring zones. The

thin ribbons of one component in another rapidly become diffuse and finally disappear through molecular diffusion.

The flow pattern may be analyzed in terms of its three components of motion; radial flow, in a direction perpendicular to the impeller shaft; longitudinal or axial flow, in a direction parallel to the shaft; and tangential flow, in which the liquid follows a circular path around the shaft. A satisfactory flow pattern depends on the correct balance of these components. In a cylindrical tank, radial flow will give rise to axial flow by reaction at the wall of the tank. Tangential flow receives no such modification. Its predominance as laminar flow circulation supports stratification at various levels. Furthermore, a vortex is created at the surface of the liquid, which may penetrate to the impeller, causing air to be dispersed in the liquid. In general, tangential flow should be minimized by moving the impeller to an off-center position, thus destroying the symmetry of the mixer, or by modification of the flow pattern by means of baffles. Tanks with vertical agitators may be baffled by one, two, or more strips mounted vertically on or just away from the vessel wall. These reduce but do not eliminate tangential flow, whereas little modification of radial and axial flow occurs. Baffles produce additional turbulence.

Additional factors must be applied to the mixing of two immiscible liquids. This operation, which is encountered, for example, in liquid-liquid extraction, involves the production and maintenance of a large interfacial contact area. In addition, separation of phases because of differences in density must be opposed by an adequate axial flow pattern. The high rates of shear induced by the rotation of a propeller or turbine cause globules of the disperse phase to be drawn into an unstable filament of liquid, which breaks and reforms into smaller globules. Unless stabilized by surface-active agents, the reverse process, coalescence, occurs in zones where velocity gradients are small.

### **Paddle Mixers**

Four types of paddle mixer are illustrated in Figure 13.7. The mixing element is large in relation to the vessel and rotates at low speeds (10–100 rpm). A simple paddle, with upper and lower blades, suitable for mixing miscible liquids of low viscosity, is shown in Figure 13.7A. A tangential flow pattern predominates with zones of turbulence to the rear of the blades. The gate paddle (Fig. 13.7B) is suitable for mixing liquids of higher viscosity, and the anchor paddle (Fig. 13.7D), with low clearance between pan and blade, is useful for working across a heat transfer surface. Stationary paddles intermeshing with the moving element suppress swirling in the mixer, illustrated in Figure 13.7C. In the other examples, baffles are necessary. Unless paddle blades are pitched, poor axial turnover of the liquid occurs. Paddles are not, therefore, suitable for mixtures that separate.

### **Propeller Mixers**

Propellers are commonly used for mixing miscible and immiscible liquids of low viscosity. The marine propeller is typical of the group. High-speed rotation (400–1500 rpm) of the relatively small element provides high shear rates in the vicinity of the impeller and a flow pattern with mainly axial and tangential components. They may be used in unbaffled tanks when mounted in an off-center position or are inclined from the vertical. Horizontal mounting in the side of the vessel is frequently used when the scale of the operation is large.

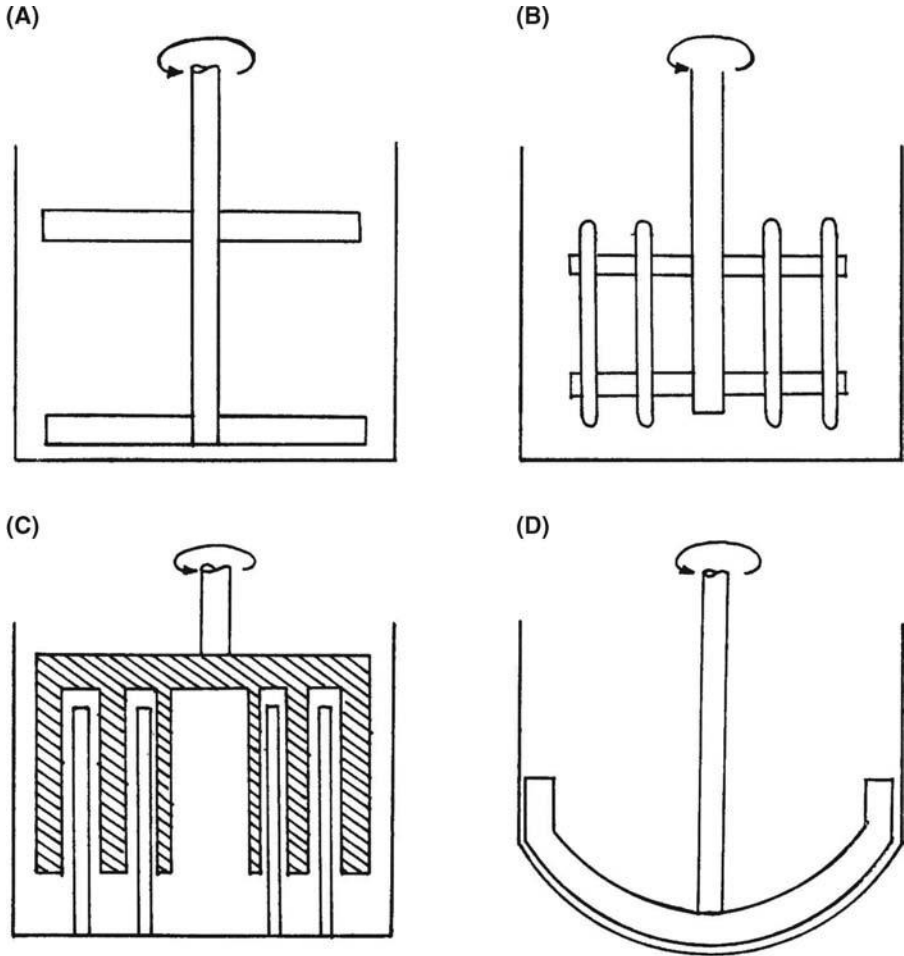

**FIGURE 13.7** Paddle mixers.

### Turbines

Turbine designs are intermediate between paddles and propellers. Turbines are effective mixers over a wide viscosity range and provide a very versatile mixing tool. The ratio of radial flow to tangential flow, which are the predominating components with this impeller, increases as the operating speed increases. Pitched-blade turbines are sometimes used to increase axial flow. Baffles must be used to limit swirling unless a shrouded turbine is used. With this impeller, a discharge with no tangential component is produced.

### THE MIXING OF LIQUIDS AND SOLIDS

Examples of solid-liquid mixing are found in the operations of dissolution and crystallization and in the control of chemical reactions between solids and liquids. Alternatively, randomization of materials for subdivision and presentation may be the object, as, for example, in the production of a toothpaste.



The flow properties of a liquid-solid mixture alter markedly with change in the ratio of the two phases. At low solid disperse phase concentrations, flow properties are Newtonian and mixing by impellers is satisfactory so long as the components of flow oppose settling. Under such conditions, it may be desirable to increase the size and decrease the speed of the impeller. For a given power input, improved flow patterns will be produced at the expense of turbulence. Unless the difference in density between solid and liquid is small, paddles are ineffective for suspending solids. Otherwise, the discussion presented for the mixing of liquids may be applied.

Anomalous flow characteristics are exhibited at higher disperse phase concentrations in which the apparent viscosity is a function of the rate of shear. The apparent viscosity may increase or, more commonly, decrease as the speed of the impeller is increased. Mixing will be achieved by suitable impellers, notably the turbine, as long as adequate flow patterns in the entire volume of the mixing vessel are created. Turbulence is less effective as a mechanism of mixing and regimes of laminar flow will be extensive.

Further increase in apparent viscosity occurs at higher disperse phase concentrations. This is often associated with the development of a yield value. Unlike true liquids, shear forces must exceed a certain level before deformation occurs. Since the shear forces developed by particles suspended in liquids are small, sedimentation does not occur and the mixture may be classified as neutral. Mixing by impellers is precluded if the apparent viscosity is very high because the projection of adequate flow patterns is impossible. Alternative methods must be used in which the mixing element visits all stations in the mixing vessel. For thin pastes, machines typified by the domestic food mixer are used. Imposition of planetary movement on the rotation of the mixing element causes all parts of the mix to be sheared at intervals. Very high shear rates are produced as the element sweeps out zones close to the wall of the container. In other machines, the containing vessel rotates.

For thicker pastes and plastics, a kneading, stretching, and folding action is employed. The sigma blade, mounted axially in a trough, is a commonly used mixing element. Intense shear is induced by the close clearance between element and container. Simultaneous transport around the trough occurs so that all portions of the mass are periodically deformed. Considerable variation in rheological properties may occur during mixing, and robust construction of the mixer is essential.

The differential speed of the rolls of the roll mill induces high shear rates in the material. This machine is suitable for paste mixing. With more fluid dispersions, the ball mill and the colloid mill may be used. Solids that aggregate may be successfully dispersed, although subsequent stability may require the addition of a deflocculating agent.

Blending solids with very small quantities of liquid, an operation commonly used for granulating powders, presents extreme problems of uniformity. If the material does not become plastic and pasty, it will not mix by shear deformation in the manner described above. Mixing is then best achieved by spraying the liquid as fine droplets onto a highly mobile powder, which is continually and rapidly developing new surfaces. In this way, all the particles can be exposed to the spray. A closed ribbon mixer, planetary mixer, or sigma blade mixer can be used. Alternatively, tumbler mixers can be fitted with a spray device. If the solid is itself a mixture, the material must be completely mixed before the liquid is added. Otherwise, homogeneity will be difficult to achieve.

## 14 Solid Dosage Forms

### INTRODUCTION

Earlier the subject of powders was addressed from a physicochemical standpoint. The unit processes involved in incorporating powders in solid dosage forms must also be considered. Solid dosage forms can be divided into granules, capsules, tablets for oral delivery, and inhalation products. Note that solid particulates might also play a role in certain parenterals in the form of reconstitutable products.

Solid dosage forms are the most desirable final products of a development process that begins with drug discovery and proceeds through bulk product manufacturing, preformulation, and formulation characterization to one of the products mentioned. Figure 14.1 illustrates an abbreviated sequence of steps through which the drug passes to the final dosage form.

Most solid dosage forms are intended for oral ingestion. The drug released from the dosage form is available at the site of absorption or action within the gastrointestinal tract.

Preformulation studies are required before a formulation is developed. By studying the properties of the drug, it is possible to delineate a course of action for composing the formulation. The properties studied are

- organoleptic properties,
- purity,
- particle size, shape, and surface area,
- solubility,
- dissolution,
- parameters affecting absorption (dissociation constant, partition coefficient),
- crystal properties and polymorphism,
- stability (chemical and physical),
- compatibility (with excipients and potential packaging materials), and
- miscellaneous physicochemical properties like

density,  
hygroscopicity,  
flowability,  
compressibility, and  
wettability.

Problem solving in service of formulation development can be derived from knowledge of these properties. Each item has been covered in depth elsewhere and is beyond the scope of this volume.

The additives employed in solid dosage forms are categorized as diluent, glidant, lubricant, disintegrant, and binder. Several candidates from each category may be considered as components of a possible dosage form. Lubricants and disintegrants play a more substantial role in compressed tablet dosage forms than they do in granules or capsules. This will be discussed in more detail later.

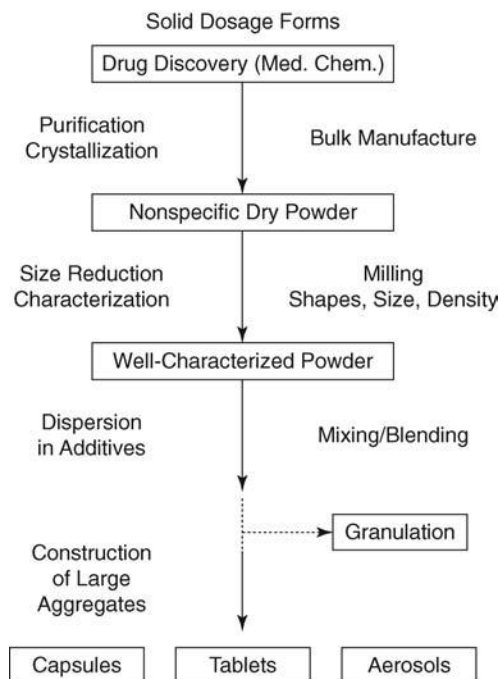

**FIGURE 14.1** Drug to the final dosage form.

## GRANULATION

The simplest form of solid dosage form employs granules prepared from the drug and other components in stable aggregates in sizes large enough to facilitate accurate manipulation and dispensing in bulk and at the level of the unit dose.

Following particle size reduction and blending, the formulation may be granulated (Carstensen, 1993), which provides homogeneity of drug distribution in the blend. In addition, it may help flow properties and powder compression characteristics. Large granules can be prepared from primary particles by drying from a slurry (with techniques described elsewhere in this text) or by spraying with granulation solution. Figure 14.2A shows a top-spray granulator. An alternative method (Fig. 14.2B) employs an auger to force the blend between rollers, thereby forming a compressed solid that disintegrates into large aggregates (Doelker, 1994).

The steps involved in granulation begin with transferring powders to a mixer and blending the product. The granulation solution can be added, and coarse milling or wet granulation begins. Finally, the product is dried and milled to an appropriate size. If the powder is unstable in the presence of polar solvents, it may be compressed directly. Granulation increases the uniformity of drug distribution in the product, improves the powder flow rate and uniformity of flow, and, if used as an aid to tableting, assists in compression and bonding.

More sophisticated approaches to combining the drug and excipients into a free-flowing large particle size to improve homogeneity, handling, and drug release characteristics include spray drying, fluid bed drying, extrusion

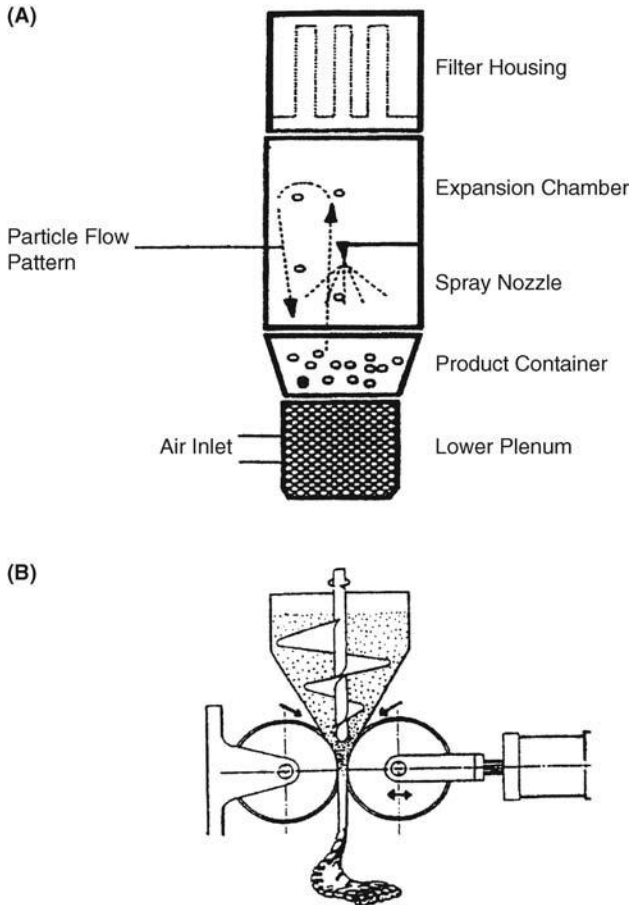

**FIGURE 14.2** (A) Top-spray granulator. (B) Granulator with an auger to force the blend between rollers (Chilsonator).

spheronization, and microsphere or microcapsule formulation. All of these processes are governed to some degree by fundamental fluid flow, heat, and mass transfer phenomena.

### HARD CAPSULES

Hard capsules have traditionally been manufactured from gelatin. The gelatin is obtained from bone or skin (calf or pig) acid or alkali treatment over a period of weeks, in some cases as long as 30 weeks (pork skin, 1–5% HCl). The product pH is adjusted, and a hot water extraction is followed by filtration, concentration, and solidification. The final product is milled to size.

Capsule shells are prepared by dipping manganese bronze pins into a bath of molten gelatin. Once removed from the bath, the gelatin solidifies on the pins. The caps and bodies are then dried and trimmed. Colorant or titanium dioxide (for opacity) is added as part of this process.

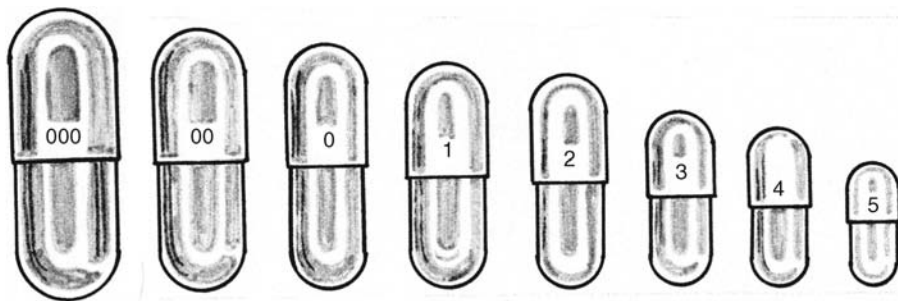

**FIGURE 14.3** Different capsule sizes.

The need for capsules with different physicochemical properties, to aid in stability, for example, has promoted a search for alternative materials. In addition, individuals who, for strict religious or health reasons, cannot ingest gelatin, need alternative products. In this regard, starch and hydroxypropylmethyl cellulose (HPMC) have been developed. There is no reason to believe that other film-forming polymers might not be useful in this regard. One significant issue that must be considered is the moisture content of the capsule. Gelatin is known to optimally contain 5% to 15% moisture. Below 5%, the shell becomes brittle and may shatter. Above 15% the gelatin distorts, and the shape of dosage form, if not its integrity, is challenged. The presence of a nutrient-rich environment and moisture may offer an ideal situation for microbial growth and enzyme action. Control of microbial growth is, therefore, a serious consideration in the preparation of capsule products.

Various capsule sizes are manufactured, as shown in Figure 14.3. There are no strict rules for predicting required capsule size. Capsules are selected on the basis of their capacity and the nature of the formulation to be added. The bulk density and compressibility of the product (drug and excipients) dictate the quantity of drug that can be placed within a capsule of known volume. Since the drug dose required to achieve a therapeutic effect can be estimated for new compounds and is known for existing compounds, this information can be used in conjunction with the capsule volume to select an appropriate size.

The requirements for capsule production depend on the scale of manufacturing. Extemporaneous preparation (6–12 capsules) usually employs enough of the product formula to fill one more capsule than required, to account for loss of fill in manipulation. Special consideration should be given to controlled substances where all of the drug must be accounted for. Industrially (thousands), the amount necessary to fill the desired number can be prepared because the error will be small on such a large scale. The operations involved in large- or small-scale capsule filling are the same. The capsules as supplied in random orientation must be rectified into a bodies-down, caps-up orientation. The two shells are then separated, and the capsule is filled with product formulation. Various methods are available to fill the capsules. For small-scale production, a plate or single capsule filling method is employed. On a larger scale, tamping, intermittent compression, continuous compression vacuum, or auger filling may be employed (Fig. 14.4). The shells are then joined and sealed, and the completed product is discharged, as shown in Figure 14.5. Different locking

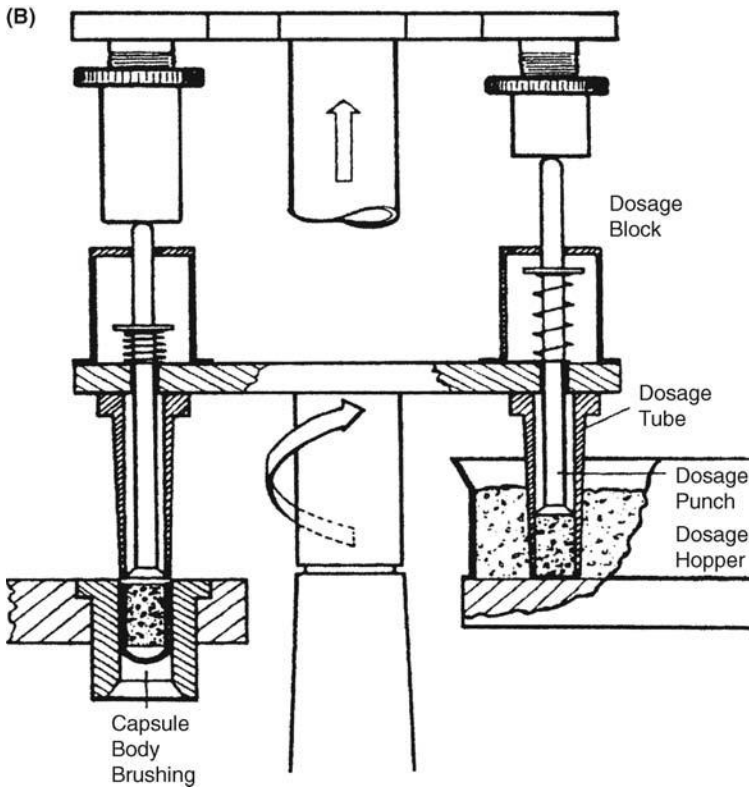
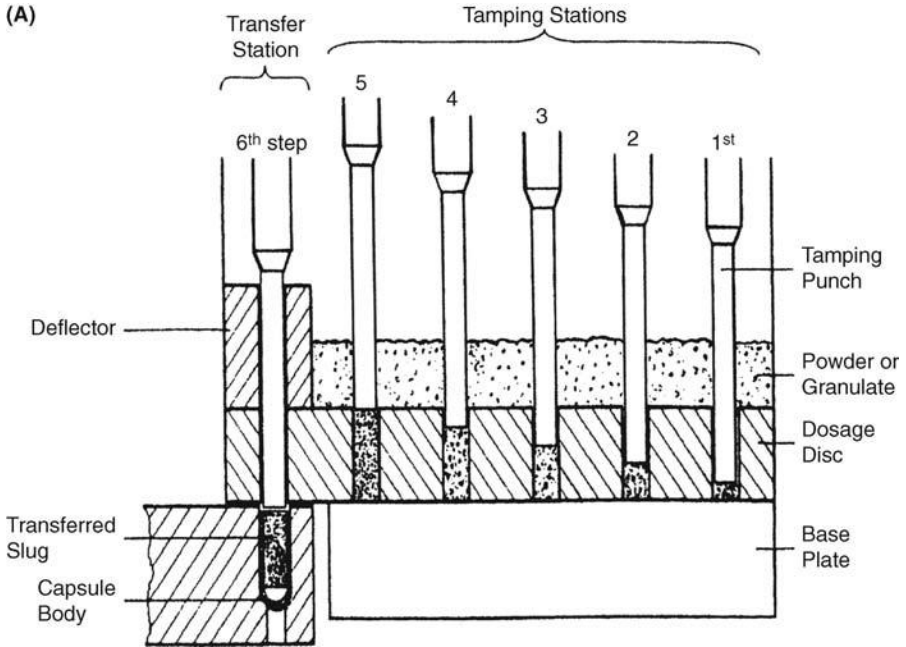

FIGURE 14.4 Capsule filling: (A) tamping, (B) compression, and (C) auger filling.

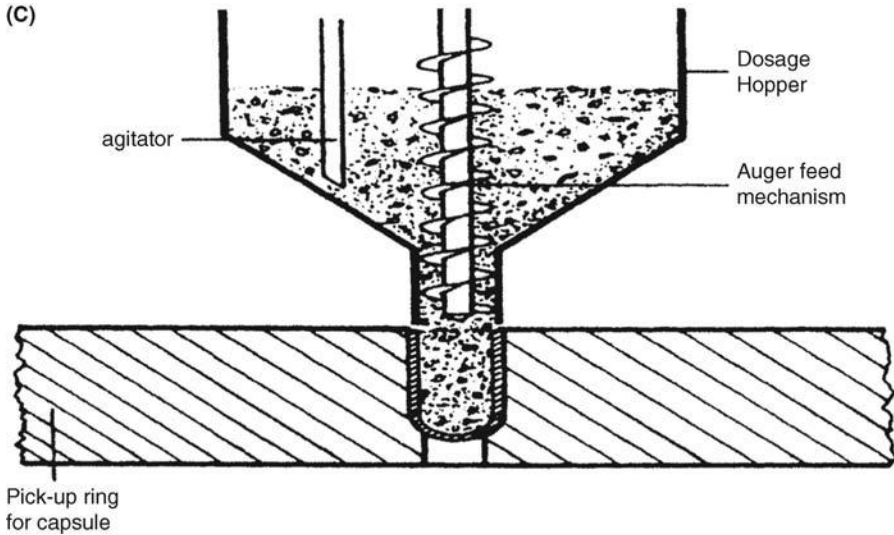

FIGURE 14.4 (Continued)

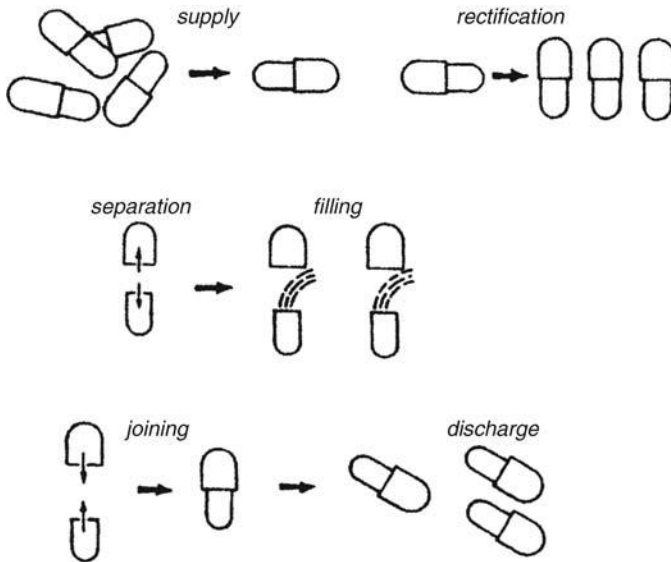
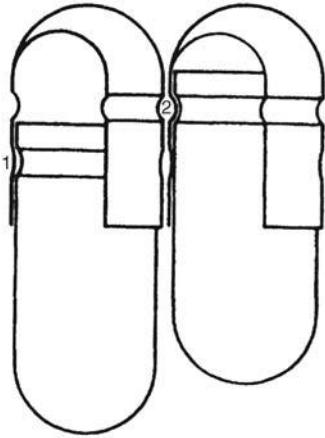

FIGURE 14.5 Capsule manufacturing process.

mechanisms have been developed for capsules shown in Figure 14.6. A cleaning and polishing step also follows the manufacturing procedure to improve product appearance.

The product is visually inspected following production, its potency and uniformity are evaluated, and it is transferred hygienically to the final



**FIGURE 14.6** Capsule locks.

packaging. If the product is hygroscopic, it may be necessary to package capsules with desiccant to avoid moisture uptake. Alternatively, impervious packaging materials, such as aluminum blisters, may be used. Capsules are easier to prepare than tablets, are quite flexible with respect to dose, and are easily combined with other solid dosage forms since other capsules or tablets can be incorporated into larger capsules.

## TABLETS

Additional processes are required for tablet production beyond those described previously. Because these processes are not ubiquitous in pharmaceutical manufacturing, they are dealt with only briefly here. Many of them are required for all solid dosage forms. Each process must be conducted while balancing the effects of the respective excesses.

Compressed solids, tablets, or caplets are prepared by placing the blend of component additives in a cylinder or die, above a movable piston or punch. An upper punch is brought into the top of the piston, and pressure applied to the distal ends of the punches forces the powder into a compact (Fig. 14.7). Product quality depends on the cohesive forces acting on the powder under compression. These cohesive forces are influenced by the selection of additives in the dosage formulation. One method of evaluating tablet manufacture considers the effect of applied pressure on porosity of the compressed powder (Carstensen, 1993). Data may be plotted as the negative natural logarithm of porosity against applied pressure in the form of a Heckel plot (Heckel, 1961). The slope is proportional to the yield value ( $\varphi$ , elastic limit)  $1/3\varphi$ .

The tooling of a tablet press varies according to the tablet design. Consideration must be given to the distribution of forces across the faces of the tablet punches as they are brought together to compress the tablet in the die. As more unusually shaped tablets are produced and more elaborate embossing tools are required, the forces are not distributed evenly across the punches, and care must be taken if they are to have a reasonable, useful life span. Mathematically, finite element analysis can be used to characterize these forces and to calculate the requirement for preserving the tools for extended periods.



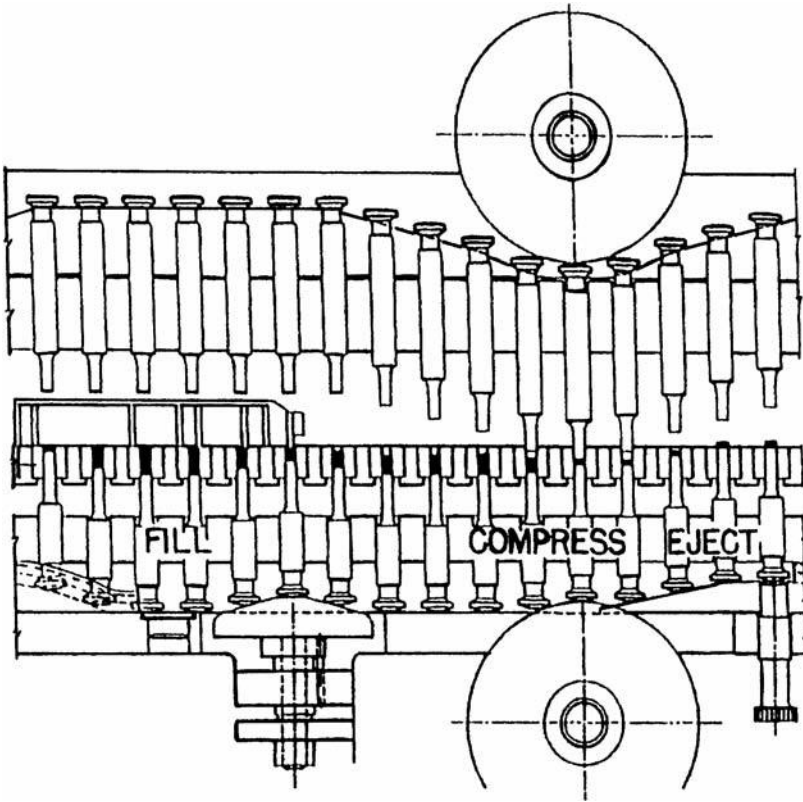

**FIGURE 14.7** Tablet manufacture depicting the three steps of filling, compression, and ejection.

Coating is achieved by placing a batch of tablets in a coating pan and spraying or coating from solution with the required polymer. The Accela-Cota (Fig. 14.8) is one of the more common coating systems.

Tablets have been prepared with different characteristics and for different purposes. The most common tablets are uncoated, coated, chewable, or effervescent. Some specialized dosage forms have been developed for sublingual and buccal delivery. A typical uncoated conventional tablet might have the composition shown in Table 14.1. Examples of such systems include generic aspirin and Valium. These tablets are designed for rapid dissolution.

Tablets may be coated for a variety of reasons, including better appearance, taste masking, ease of swallowing, protection from light, protection from gastrointestinal irritation, facilitating tablet printing, and control release. The formulation of a coated tablet is similar to that of an uncoated tablet. Usually, it is coated from a solution of polymer, for example, methylcellulose, enteric polymer. Bayer aspirin or erythromycin products are examples of coated tablets.

Chewable tablets are usually flavored and contain additives that contribute to a smooth texture, including glycerin and sugars such as mannitol and sorbitol. An example is Tylenol chewable tablets.

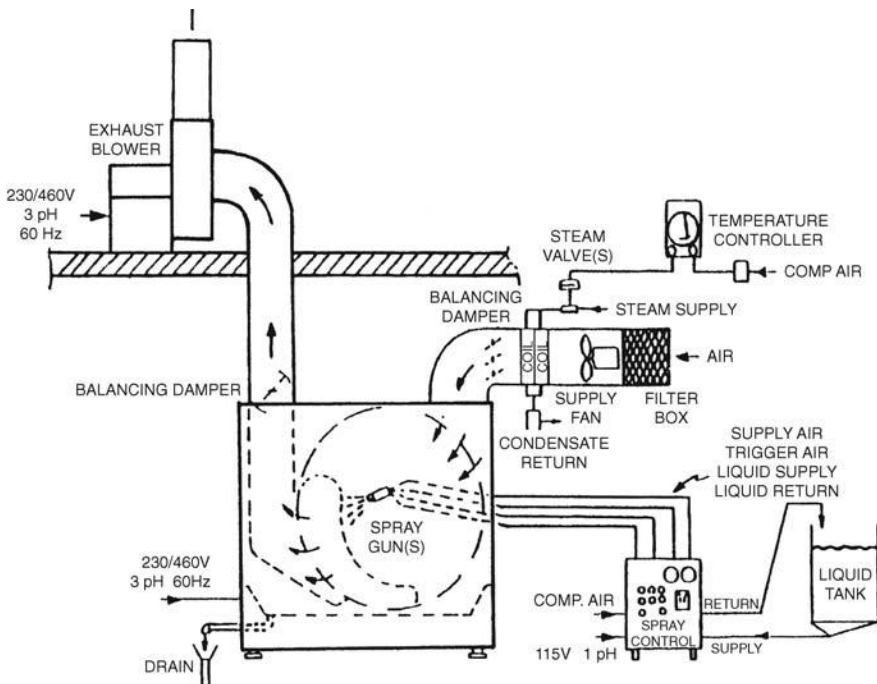

**FIGURE 14.8** Accela-Cota. *Source:* Courtesy of Thomas Engineering, Hoffmann Estates, Illinois, U.S.

**TABLE 14.1** Tablet Composition

Purpose	Examples
Drug	Generic aspirin, Valium
Filler	Lactose, sucrose, phosphates
Binder	Starch, polyvinylpyrrolidone, cellulose
Glidant	Talc, silicon dioxide
Lubricant	Magnesium stearate
Disintegrant	Starch, sodium starch glycolate
Colorant	Various

Effervescent tablets are formulated so that an acid-base reaction occurs when they are combined with water. This is achieved by using weak acids (e.g., citric, malic, tartaric, or fumaric acids) or bases (e.g., sodium or potassium carbonates) in the product. The best known of these products is Alka-Seltzer.

Sublingual tablets are designed to disintegrate and dissolve instantly. Hence, they must have structural integrity sufficient for storage, transport, and administration but capable of dissolution on the oral mucosa under the tongue. Nitroglycerin tablets designed for treating angina are prepared in a compositionally simple formulation of lactose massed with 60% ethanol. This route of administration is intended to avoid first-pass liver metabolism. Testosterone tablets have been prepared for buccal delivery by slow dissolution. The tablet

does not contain a disintegrant and is intended to have an extended residence time in the buccal cavity at the rear of the mouth. Since release is not immediate, drug dosage may be significantly reduced by this route.

### INHALATION PRODUCTS

Solid particles are employed in two types of inhalation product: the pressurized metered-dose inhaler (pMDI) and the dry powder inhaler (DPI). In both cases, the method of choice for manufacturing particles in an appropriate size range to deposit in the lungs ( $<5\ \mu\text{m}$ ) is attrition milling by air jet mill.

The pMDI product is prepared as a nonaqueous suspension in which surfactant is used to disperse the drug particles in high-vapor pressure propellants. Once the particles are prepared, the product formulation depends only on the particle dispersion in suspension, their ease of redispersion, and their physical stability upon aerosolization. Figure 14.9 shows a typical filling line for pMDI product.

DPI formulations usually involve a combination of the micronized drug with a carrier, notably lactose. The carrier particles are usually larger than the drug particles and outside the range required for lung deposition ( $>30\ \mu\text{m}$ ). The purpose of these large particles is to help disperse the respirable drug particles carrying them into the inspiratory airflow where they are stripped from the surface as a function of the large shear forces. These formulations are prepared in capsules, blisters, or reservoir devices. The filling technology has been developed to accurately meter small doses into the unit-dose packaging.

Other methods of particle preparation have been evaluated, including spray drying and supercritical fluid manufacture. The capacity to manufacture particles with known and optimized particle size, shape, and surface characteristics is intriguing, and it seems likely that these methods will become more significant in the future and may even surpass micronization for aerosol delivery of drugs.

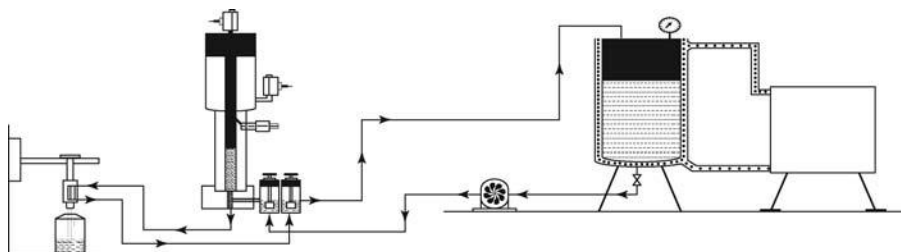

**FIGURE 14.9** Metered-dose inhaler filling line.

**INTRODUCTION**

Sterilization processes do not result in a product that can be described as absolutely sterile or nonsterile. The process is a statistical phenomenon. A variety of techniques are available (Avis and Akers, 1986). These methods include heat, radiation, ethylene oxide sterilization, and sterile filtration.

**THERMAL STABILIZATION**

The use of heat to sterilize is dependent on the magnitude ( $T$ ), duration ( $t$ ), and amount of moisture present.

$$t \propto 1/T$$

It is thought that the heat coagulates protein in the living cell. The temperature required for this phenomenon to occur is inversely proportional to moisture present.

**Dry Heat**

Relatively stable substances that resist degradation at high temperatures ( $>313$  K) are suitable candidates for dry heat sterilization. Two-hour exposure at 353 K or 45-minute exposure at 433 K kills spores as well as vegetative forms of microorganisms. These exposure periods do not include the lag time from loading of the oven until sterilization temperature is achieved. The lag time depends on the geometry and operating features of the oven and characteristics of the load.

The oven types that can be employed are natural and forced convection, both of which are described in chapter 7, "Drying." The forced convection oven offers the advantages of uniformity of heat distribution and reduction in lag time in comparison with the natural convection system.

This method is reserved almost exclusively for glass or metal, as other materials char (cellulose), oxidize (rubber), or melt (plastic) at these temperatures.

**Moist Heat**

Moist heat offers the advantage of greater effectiveness at low temperatures. The thermal capacity of steam is much greater than that of hot air.

Spores and vegetative forms of bacteria may be effectively destroyed in an autoclave employing steam (394 K) under pressure ( $1.03 \times 10^5$  N/m<sup>2</sup>) for 20 minutes or ( $1.86 \times 10^5$  N/m<sup>2</sup> at 405 K) for 3 minutes. The lag time to complete exposure of the material to be sterilized is important.

**RADIATION**

Ultraviolet (UV) light is frequently employed to reduce airborne microbial contamination and for surface sterilization. This is usually achieved by utilizing mercury vapor lamps with an emitted light of  $2.537 \times 10^{-7}$  m.

Radiation sterilization includes the use of the ionizing radiation of X rays and  $\gamma$  rays. X rays are derived from bombardment of a heavy metal target with electrons.  $\gamma$  Rays are obtained from atomic nucleus decay from the excited state to the ground state.

The energy evolved from radiation can be equated to photon behavior as follows:

$$E = h\nu$$

and

$$\nu = \frac{C}{\lambda}$$

where  $E$  and  $\nu$  are the energy and frequency of a photon, respectively,  $h$  is Planck's constant, and  $C$  and  $\lambda$  are the speed and wavelength of light, respectively.

The energy absorbed from the radiation sources equates to the dose.

$$\begin{aligned} 1 \text{ rad} &= 100 \text{ ergs/g of material absorbing} \\ &= 6.24 \times 10^{13} \text{ eV/g} \\ &= 2.4 \times 10^{-6} \text{ cal/g} \end{aligned}$$

There are a variety of radiation sources.  $^{60}\text{Cobalt}$  ( $^{60}\text{Co}$ ) decays to  $^{59}\text{Co}$  in the core of a nuclear reactor to emit two photons ( $1.17 \times 10^6$  eV and  $1.33 \times 10^6$  eV) and an electron ( $0.31 \times 10^6$  eV). The half-time for decay is 5.3 years.  $^{137}\text{Cesium}$  ( $^{137}\text{Cs}$ ) decays emitting one photon ( $0.661 \times 10^6$  eV). Cesium has a 33-year half-life. An electron beam can be accelerated to energy equivalent to  $5 \times 10^6$  to  $10 \times 10^6$  eV. At energies below  $5 \times 10^6$  eV, penetration is insufficient for sterilization. Energy above 10 MeV may induce untoward effects of radioactivity. The depth of penetration of radiation can be correlated with energy levels. For example, materials with density equivalent to water ( $\rho = 10^6 \text{ g/m}^3$ ) are penetrated  $5 \times 10^7 \text{ m/eV}$ .  $^{60}\text{Co}$  gives rise to radiation that penetrates 0.3 m through water. Accelerating electrons have high dose rate, and exposure is only required for seconds.  $^{60}\text{Co}$  has a lower dose rate, so an exposure for hours is required.

Ionizing radiation arises from the photoelectric effect, the Compton effect, or ion pair production.  $\gamma$  Radiation causes local and intense damage and may break chemical bonds. The primary target is the deoxyribonucleic acid (DNA) of the microorganism. In addition, free radicals may be formed, that is, peroxides that result in intracellular and extracellular peroxides by a chain reaction that cause damage.

### Resistance to Damage

Damage depends on the amount of energy absorbed relative to the number and resistance of the microorganisms being irradiated. Unicellular organisms have greater resistance than multicellular ones. Gram-positive bacteria have greater resistance than gram-negative bacteria. Finally, bacterial spores have greater resistance than vegetative forms. Viruses are more resistant than bacteria. The energy required to reduce the population of viruses by 90% (D-value) is  $5 \times 10^5$  rad. Fungi are equivalent to bacterial spores in their resistance.

To evaluate the dose, a number of parameters must be known. What magnitude of source (e.g.,  $^{60}\text{Co}$ ) is available? A typical source ranges between

500,000 and 2 million curies (Ci) where 1 Ci is  $3.7 \times 10^{10}$  disintegrations/sec. The product geometry and the speed of the conveyor carrying it to the source must be known. The dose can be evaluated by a variety of dosimetric techniques. In bulk or ampules containing liquids, ferric ammonium sulfate and ceric sulfate can be used to show an absorbance change, evaluated by UV spectrophotometry. This is only accurate for  $^{60}\text{Co}$  and  $^{137}\text{Cs}$ .

Radiochromic solids can be utilized and evaluated by visible spectrophotometry. Amber and red polymethylmethacrylate are used to evaluate  $0.1 \times 10^6$  to  $1.0 \times 10^6$  or  $0.5 \times 10^6$  to  $5.0 \times 10^6$  rad, respectively. Nylon film is examined for opacity following exposure and may be used to evaluate exposures of  $0.1 \times 10^6$  to  $5.0 \times 10^6$  rad.

Validation requires the determination of the bioburden and the D-value. These represent the dose required to achieve sterilization and the estimated dose.

The dose may be regarded as overkill if low D-values are obtained. *Bacillus pumulis* exhibits inherently high resistance to  $\gamma$ -ionization radiation with D-values of  $0.15 \times 10^6$  to  $0.22 \times 10^6$  rad. The Food and Drug Administration would like a 12-log reduction in microorganisms. The dose required is approximately  $2.6 \times 10^6$  rad.

### Product Development

The product, container, and closure must be evaluated for physical and chemical stability. A number of radiation-induced changes can potentially occur. The product may change in color, odor, flavor, potency, biocompatibility, and toxicity. The container may lose rigidity, become brittle, label adhesion, and become leachable. The product and container may be assessed by exposure to multiple doses and single high doses of radiation. The long-term stability can then be evaluated under ambient storage conditions, at elevated temperatures, and under worst-case shipping conditions.

Dose mapping can be performed by determining the minimum radiation point in the load. Multiple dosimeters can be used to view vertical quadrant through the load. Dosimeters are routinely set to measure the minimum dose.

### ETHYLENE OXIDE

Ethylene oxide is a gaseous alkylating agent. It alkylates proteins, ribonucleic acid and DNA in microorganisms. It replaces labile oxygen with ethylene hydroxide. Ethylene oxide is utilized as a surface sterilant. Bulk crystalline materials can occlude vegetative bacterial cells or spores, with crystals. Consequently, ethylene oxide will not reach them. The final step prior to sterilization is an aseptic recrystallization step.

Ethylene oxide is a colorless gas with an aromatic odor. The threshold limit for the odor is 700 ppm. The OSHA specification for worker exposure is 10 ppm. The toxicity of ethylene oxide is similar to that of ammonia. It causes conjunctival and respiratory irritation, dizziness, headaches, and vomiting. It is known to be mutagenic and may be carcinogenic. There are some byproducts of ethylene oxide (boiling point 283.8 K) including ethylene glycol (boiling point 471.9 K) and ethylene chlorohydrin (boiling point 401.4 K). Pure ethylene oxide is flammable and explosive. It is generally mixed with propellant (88:12) or carbon dioxide (90:10). Ethylene oxide polymerizes in the liquid state. In this

form, it may plug lines or spray polymerized sludge on the product. The product expires in 90 to 120 days because of the polymerization.

Ethylene oxide inactivates all microorganisms. The cidal rate depends on the concentration of gas, the temperature of sterilization, the duration of exposure, and the water content of the microorganism. Inactivation follows classical first-order kinetics. Inactivation is irreversible. Relative humidity is synergistic with ethylene oxide. At 30% to 60% relative humidity, the microorganism hydrates. The water acts as a vehicle to transport the gas through polyethylene and polypropylene. Polystyrene traps ethylene oxide and dissipates it over years and is thus not appropriate for ethylene oxide sterilization. Temperatures of 313 to 333 K are suitable for heat-labile items. Cycle times are longer if temperatures, relative humidities, or ethylene oxide concentrations are lower. Generally, concentrations of 350 to 700 mg/mL are employed. Cycle times vary from 4 to 12 hours.

Following sterilization, the load is degassed. This is a dynamic process wherein filtered air is passed over the product. The time for degassing is 12 to 72 hours. This is usually performed in the treatment chamber but may be moved to a sterile facility. The process is monitored using *Bacillus subtilis var. niger* as a biological indicator. Spore strips ( $10^6$  spores/strip) can be purchased for this purpose. During validation, the load is probed with thermocouples in addition to *B. subtilis* spore strips. Gaseous mixture is sampled from different points in the sterilizer for gas chromatographic analysis.

## STERILE FILTRATION

Several filter geometries are available to perform sterile filtration. These consist of flat membranes in a stainless steel press ( $<0.293$  m), pleated membranes housed in stainless steel cartridges, and stacked plates in the form of flat segments of membrane filters.

Matrix filters consist of fibers with pores having a depth of up to  $1.2 \times 10^{-4}$  m. Cellulose nitrate may be dissolved in the highly volatile solvents amyl acetate, ether, and dioxane. A gel-forming solvent, acetone, ethanol, or propanol, may be added. The mixture is poured on a flat plate and placed in a controlled-temperature environment to dry. Pore size is dependent on the gel-forming solvent concentration. A number of other substances may be used as filter material. These include other cellulose esters, acetate and butyrate; polyamides (nylon); polysulfones; fluorocarbons (Durapore membranes), polyvinylidenedifluoride (hydrophobic) or surface modified with organic amides (hydrophilic); acrylic polymers; and polyvinyl chloride. To make some membranes hydrophilic, surfactants may be added including Tween 80, Triton X-100, hydroxypropyl cellulose, and glycerol. Sieve filters are made of polycarbonate (nucleopore  $10^{-5}$  m thick). Collimated uranium fission products form nucleation tracks in film. Etching chemical exposure determines pore size.

## Adsorption and Screening

Most membrane filters, when wetted, have negative charge. Bacteria have a similar negative charge and do not necessarily remain on the filter. Filters with other characteristics can be selected under these circumstances. Positively charged (AMF Zeta Plus Membrane) or protein- and peptide-adsorbing (Pall Posidyne Nylon 66) filters can be selected.

Ionic strength, pH, pressure, and flow rate all effect adsorption of particles. The flow rate through a filter is described in equation (1).

$$Q = \frac{C_i A P}{V} \quad (15.1)$$

where  $C_i$  is the inherent resistance of the filter to flow (a function of void volumes),  $A$  is the surface area,  $P$  is the pressure, and  $V$  is the viscosity.

Filters are related according to nominal pore size and absolute pore size (the largest pore in the filter). This recognizes that a pore size distribution exists.

### Filter Integrity

The filter integrity can be evaluated by a number of techniques. The destructive test involves filtering a suspension of bacterial cells (*Pseudomonas diminuta*,  $0.3 \times 10^{-6}$  m) through a  $2 \times 10^{-7}$  m filter. Six liters of suspension containing  $1 \times 10^{10}$  org/L grow up on an agar plate. Downstream of a  $10^{-6}$ -m filter, there should be nothing and an 8-log reduction would have occurred. The bubble point test assumes that pores can be characterized as capillaries. When totally wetted, all the capillaries should be full of water or solution. The pore length is generally much greater than the diameter. Pressure is applied to the wetted filter. The bubble point pressure ( $P$ ) may be described as follows:

$$P = \frac{4 \gamma \cos \theta}{D} \quad (15.2)$$

where  $\gamma$  is the surface tension ( $7.2 \text{ N/m}^2$ ),  $\theta$  is the contact angle, and  $D$  is the diameter of capillary.

The bubble point test is performed before and after sterile filtration.

### Product Development Considerations

A specified area of filter must be soaked in a specified volume of product for a designated time. The accelerated stability of a product in the presence of a filter can be performed at 313 to 333 K for 60 days. The extent of damage, nature and quantity of extractables, and potency of active ingredients must be evaluated prior to selection of a filter for a particular process.



---

## **16** Bioprocessing

### **INTRODUCTION**

Bioprocess engineering utilizes microbial growth to produce therapeutic agents of biological origin. In the current climate of recombinant (DNA) technology, this often means using host microorganisms as expression vectors for a product, most frequently a protein or peptide. Many of the principles employed in bioprocess engineering encompass fundamentals and unit processes described elsewhere in the text. All of the fundamentals apply, namely fluid flow and heat and mass transfer. Therefore, unit processes such as pumping (pumps and pipes), sterilization, filtration, heating, and ventilation have an application in bioprocessing. This section covers topics not dealt with earlier: pharmaceutical water systems, bioreactor design, integration and control systems, and product purification.

### **PHARMACEUTICAL WATER SYSTEMS**

In general, pharmaceutical water systems employ combinations of technologies described earlier. However, since the objective is unique, we review some of these methods while introducing issues that are specifically related to the production of different qualities of water (Kuhlman and Coleman, 1995). Table 16.1 summarizes water treatments and uses.

#### **Pretreatment and Sources of Water**

Potable (drinking) water is not suitable for pharmaceutical purposes. The United States Environmental Protection Agency limits allow 500 recoverable microorganisms per milliliter, none of which can be coliform organisms in drinking water. Drinking water requires further treatment to meet the requirements for use in pharmaceutical processes.

Water is pretreated to remove materials likely to be detrimental to the purification equipment. This pretreatment takes many forms. A multimedia bed (different gravels in a carbon steel vessel) is used to remove solids from the municipal water. Common problems include high bacterial or particulate counts in the effluent. This technique is highly inefficient because the container is susceptible to corrosion, the media is porous, and the piping contains dead legs, cracks, and crevices.

#### **Water for Injection**

Water for injection (WFI) is prepared following pretreatment and further purification, including ion exchange, distillation, and reverse osmosis (Kuhlman and Coleman, 1995). WFI must contain 50 recoverable bacterial colonies or less per milliliter for immediate use. Its preparation by distillation or reverse osmosis renders it sterile, from which it must be protected from contamination by endotoxins or microorganisms.

**TABLE 16.1** Water Treatment

Type of water	Treatment steps
Water source (reservoir, ground)	Prefilter, sand, gravel Zeolite, alum Filter
Drinking water	Chemical treatment ( $\text{Cl}^-$ , $\text{F}^-$ ) Multiple ion exchange (anion, cation) Charcoal ( $\text{Cl}^-$ , $\text{F}^-$ ) Multiple filters (size discrimination) Reverse osmosis/distillation
WFI	

Abbreviation: WFI, water for injection.

Source: Modified from Groves (1988).

### *Ion Exchange*

Zeolite water softener is an exchanger that replaces calcium ions with magnesium ions. Regeneration of the resin is necessary and usually conducted with brine. Consequently, chloride ions that attack certain types of composite membranes may enter the feedwater stream. Bacteria may also propagate in this system.

Activated carbon filters employ a carbon steel tank filled with gravel and covered with activated charcoal (anthracite). Again, this is a source of bacteria and chloride ions. Deionized water is produced by passing treated water through a mixed-bed or a two-bed cation/anion exchange resin system. The resulting water is deionized because hydrogen ions replace cations and hydroxyl ions replace anions. Deionized water has little or no bacteria and is easily regenerated. The potential for microbial contamination during some of these purification procedures renders additional steps necessary to prepare water suitable for pharmaceutical processing.

### *Distillation*

Distillation separates water from other soluble and insoluble components by elevating the temperature to that at which vapor forms ( $100^\circ\text{C}$ ) in a boiling chamber and then condensing the vapor into a receiving vessel. The nature of hydrogen bonding of water imparts a unique property to water. Although it can be raised to  $100^\circ\text{C}$  with a relatively small amount of energy (80 kcal), it takes almost seven times this amount (540 kcal) to break the hydrogen bonds and release the water as steam at the same temperature. Consequently, in the condensation phase, eight times as much water at  $5^\circ\text{C}$  (refrigeration temperature) is required to condense the water as steam. These large exchanges of heat may be used in an efficiently designed still to heat up water entering a second still. Alternatively, the combined gas law can be utilized by compressing vapor and therefore elevating its temperature (vapor compression still).

### *Reverse Osmosis*

Reverse osmosis units vary in design, construction materials, and membrane type more than any other unit in the pretreatment process. Usually it is a single-pass system (may not eliminate chlorides). Transmembrane pressures must

be maintained. Osmosis is the process whereby a solution separated from pure water by a semipermeable membrane induces movement of water toward the region of high solute concentration. This would ordinarily give rise to an osmotic pressure. If pressure is applied against the osmotic pressure head, the flow of water can be induced in the opposite direction, thereby reversing osmosis. This process, which may be regarded as a form of filtration, removes materials of sizes down to 200-Da molecular weight in a sequence that usually removes particulates and viable microorganisms and contaminates molecules sequentially according to size (i.e., large particles, bacteria, viruses, pyrogens, and ions). Softened pH-adjusted water is used to maximize the efficiency of ion removal. The ionic radius affects ion removal, with multivalent ions more readily removed than monovalent ions.

### **Storage and Distribution**

The water temperature at the point of use must be such that the water can be handled without risk. A recirculating ambient loop or a heat exchanger at the point of use may be required. A sophisticated system of loops and heat exchangers is required to elevate the water temperature before it returns to a storage tank. One approach is to maintain an ambient loop during the day and heat the water during the night. If the water is maintained at ambient temperatures for not more than 24 hour, the conditions do not violate current good manufacturing practice (cGMP) regulations.

### **Quality Control**

Conductivity and resistivity are convenient online measures that ensure water quality. As it circulates, water loses resistivity, stabilizing at about 5 M $\Omega$ /cm. Some corrosion may take place in the distribution system, which may ultimately lead to adulteration of the water. Endotoxin levels are monitored by sampling. Sampled water may be subjected to the limulus amebocyte lysate test to measure the presence of endotoxin. This *in vitro* assay was predated by rabbit pyrogen testing, which involves monitoring the rabbit's core body temperature in response to injection with a water sample. Endotoxin may cause mild immune responses that will be detected by an increase in body temperature.

### **Validation**

Validation of any process is required in pharmaceutical manufacturing. The validation master plan outlines the required content and method of preparing validation documentation. Validation is integral to the start-up of the entire plant. Three major sections of the validation procedure are the following:

1. Installation qualification (IQ): establishes and documents that the unit or system was installed correctly per the manufacturer's specification
2. Operational qualification (OQ): establishes and documents that the unit or system operates as intended
3. Production qualification (PQ): establishes and documents that the unit or system can fulfill its intended purpose on a reproducible basis when challenged with realistic worst-case conditions

The master plan should include a listing of documentation included in validation files for each system (reference files, vendor data, calibration reports,

standard operating procedures, and inventories). Critical path schedules, manpower estimates, operator responsibilities, auditing procedures, and outside validation resources should be included in validation documentation. Outside validation resources should be recruited. They may include purchase of validation protocols from commercial vendors, acquisition of data on validation exercises from equipment vendors, use of testing laboratories for performance qualification, contracting with other qualified agencies to perform water sampling, and, in the extreme case, contract with a qualified agency to perform the entire validation exercise (including writing protocols and performing validation testing). The scale of operation and internal resources dictate which option to select.

## CELL KINETICS

### Definitions

The principles of bioreactor design require understanding the phenomena intended to take place in these controlled environments. This relates to the growth kinetics of prokaryotic or eukaryotic cells derived from animal, plant, or microbial origins. The complexity of biochemical reactions and transport phenomena render accurate predictive mathematical modeling impossible since the system consists of multiple phases having many components. Attempts have been made to estimate growth kinetics based on a matrix combining unstructured or structured approaches to distributed or segregated models (Table 16.2).

### Growth Cycle

The growth cycle of cells has been documented for over a century. It consists of six phases that describe cells growth from an initial period of accommodation or acclimatization through to exhaustion or overpopulation of the environment. The lag phase, which occurs when cells are introduced into a medium, is a period of time when no net change in cell number occurs. This phase is followed by an accelerated growth phase when the cell numbers start to increase and the division rate increases to reach a maximum in the exponential growth phase, where the division rate is proportional to  $d \ln C_{n0}/dt$ , which is constant at maximum value. Following this maximal growth rate, a deceleration in both growth and division occurs. The cell population finally reaches a maximum value, but the death of growing cells occurs as nutrients are depleted.

**TABLE 16.2** Various Models for Cell Kinetics

Population	Cell components	
	Unstructured	Structured
Distributed	Single cells are homogeneously distributed throughout the culture	Cell aggregates are homogeneously distributed throughout the culture
Segregated	Single cells are heterogeneously distributed throughout the culture	Cell aggregates are heterogeneously distributed throughout the culture

Source: Modified from Lee (1992).

### Monod Kinetic Parameters

Much has been written regarding the growth of cells in fermenters and chemostats (Lee, 1992). The kinetic considerations in these systems are briefly summarized below.

The Monod equation is an empirical expression describing the effect of substrate concentration on the specific growth rate, and it takes a form similar to Michaelis–Menton enzyme kinetics or the Langmuir adsorption isotherm:

$$\mu = \frac{\mu_{\max} C_s}{K_s + C_s} \quad (16.1)$$

where  $\mu$  and  $\mu_{\max}$  are growth rate and specific growth rate at half-maximum value, and  $K_s$  and  $C_s$  are a system coefficient and concentration of the limiting substrate in the medium, respectively.

Monod kinetic parameters specific growth rate at half-maximum and the system coefficient cannot be estimated with a series of individual studies as easily as Michaelis–Menton kinetics for enzyme action. The initial reaction rate can be measured accurately as a function of substrate concentration for enzymes. Cell cultures undergo an initial lag phase in growth in which Monod kinetics do not apply. Even though the Monod equation has the same form as the Michaelis–Menton equation, the rate equation is different.

The Michaelis–Menton equation describing enzyme activity takes the form

$$\frac{dC_p}{dt} = \frac{r_{\max} C_s}{K_m + C_s} \quad (16.2)$$

where  $C_p$  and  $C_s$  are product concentration and substrate concentration, respectively, and  $K_m$  is the rate constant. The Monod equation takes the form

$$\frac{dC_x}{dt} = \frac{\mu_{\max} C_s C_x}{K_m + C_s} \quad (16.3)$$

Note that the cell concentration term  $C_x$  in the Monod equation is absent from the Michaelis–Menton equation.

Measuring the steady-state substrate concentration at various flow rates, one can test various kinetic models and estimate the value of the kinetic parameters.

A linear relationship can be derived as follows:

$$\frac{1}{\mu} = \frac{K_s}{\mu_{\max} C_s} + \frac{1}{\mu_{\max}} \quad (16.4)$$

where  $\mu$  is equal to the dilution rate ( $D$ ) for a chemostat. If a certain microorganism follows Monod kinetics, the plot of  $1/\mu$  versus  $1/C_s$  yields the values of  $\mu_{\max}$  and  $K_s$  by reading the intercept and the slope of the straight line. This plot is the same as the Lineweaver–Burk plot for Michaelis–Menton kinetics. Since  $1/\mu$  approaches infinity as the substrate concentration decreases, the data is weighted too heavily at low substrate concentrations and insufficiently at high substrate concentrations. Nevertheless, this approach has the advantage of showing the relationship between the independent ( $C_s$ ) and dependent variables ( $\mu$ ). Figure 16.1 illustrates the manner in which the specific growth rate may be derived from a plot of reciprocal dilution rate versus reciprocal substrate rate.

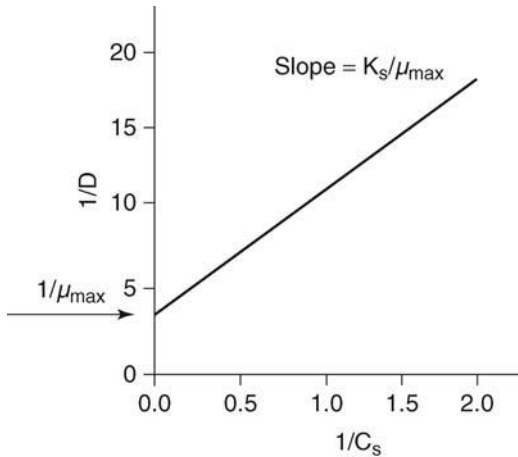

**FIGURE 16.1** Reciprocal dilution rate for a chemostat plotted against reciprocal substrate concentration.

## BIOREACTOR DESIGN

### Background

A bioreactor is a device within which biochemical transformations are caused by the action of enzymes or living cells. The simple method of shaking cells in a flask to enhance oxygenation through the liquid surface and to aid mass transfer of nutrients without cell damage has to be scaled up for industrial processing.

The use of biotechnology in the manufacture of pharmaceuticals is of increasing interest. Consequently, these techniques require attention in the planning of unit processes.

Bioprocessing can be considered in terms of small-scale bioreactors, or fermenters, and the translation of such processes into large-scale economically viable production operations (Hofmann, 1992; Tatterson, 1994). Bioprocessing is by no means a new field. The topicality of this subject is due to the increasing interest in the use of isolated cells and microorganisms as manufacturing tools. It might well be argued that the technology was developed millennia ago for the purposes of wine and beer production. More recently, the use of attenuated microorganisms or isolated antigenic materials for vaccination resulted in further developments. In the last decade, interest in genetic engineering and manipulation of the genetic code of certain microorganisms has produced a revolution in pharmaceutical manufacturing.

The major difference between a biotechnological process and other pharmaceutical manufacturing operations is the need for a bioreactor (Fig. 16.2). A bioreactor may be required to produce expressed proteins utilizing bacteria, yeast, insect, or mammalian cells. Table 16.3 illustrates the various processes (Prokop and Bajpai, 1991). It would be difficult to describe the various bioreactor elements and their permutations. Some of the simplest examples of bioreactors are shown in Figure 16.3.

Some important factors in bioreactor design are (i) sterility, (ii) broth rheology, (iii) mass transfer, (iv) mixing, (v) heat transfer, (vi) suspension homogenization, and (vii) shear sensitivity of microorganisms. The importance of these design considerations depends on the nature of the biological systems considered.

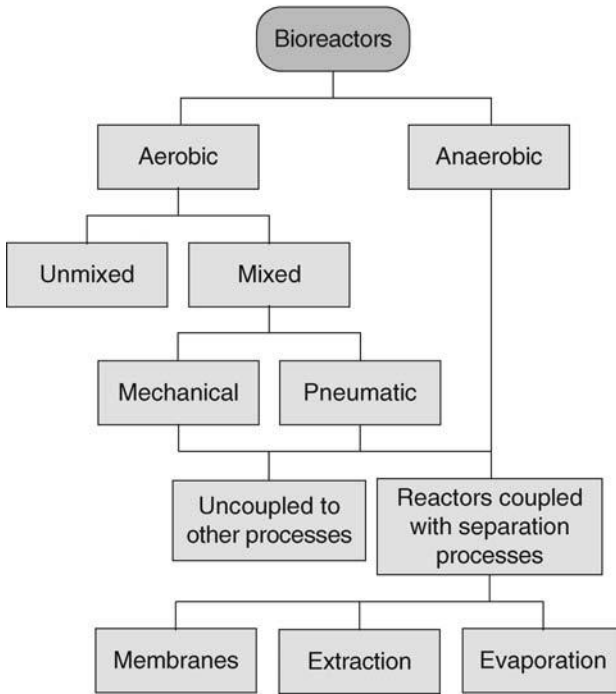

FIGURE 16.2 Types of bioreactors.

TABLE 16.3 Biotechnological Processing

Stage	Activity	Impact
First	Reactions: catabolic, anabolic, enzymatic, degradation, and stoichiometric	Molecular
Second	Metabolite translocation: compartment differentiation; genetic changes	Individual cells
Third	Growth; dispersed, segregated, and mixed culture interactions	Population of cells
Fourth	Reaction mixers: mass and heat transfer; dynamics and control; coupled to processes	Bioreactor
Fifth	Separation unit operations; process synthesis and integration; quantitative and qualitative evaluation for process design	Process design

**Rheology**

The presence of organized structures in the form of mycelial cells or bio-polymers tends to induce non-Newtonian properties in broth. The power law of plastic systems (Martin, 1993) may be employed to describe broth rheology. The viscosity and shear rate are related to the concentration of cell mass in the system. These correlations are species specific and depend on the stage of growth in the cell cycle.

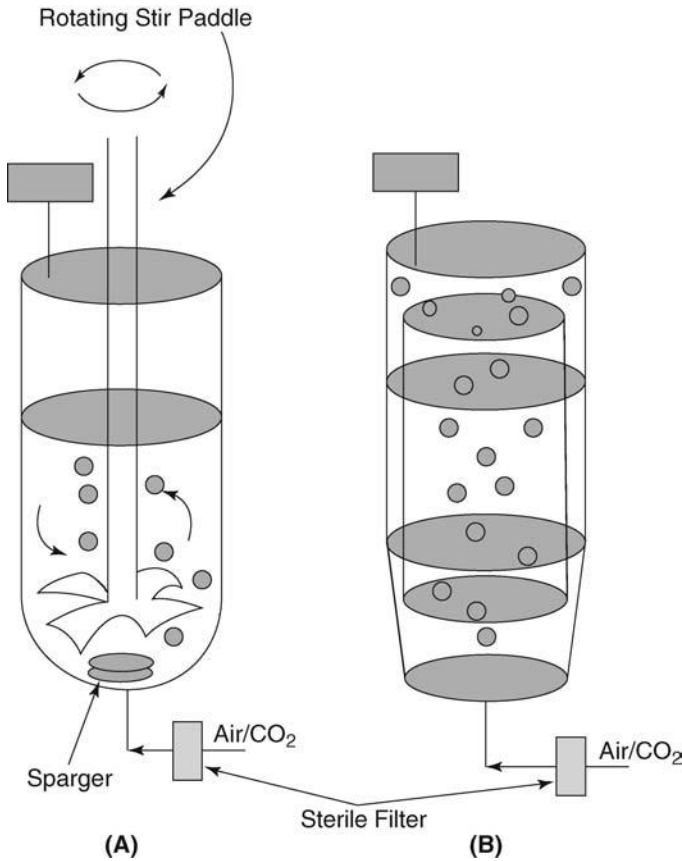

**FIGURE 16.3** Bioreactors: (A) stirred tank reactor and (B) airlift fermenter.

### Mass Transfer

Although all nutrient, waste product, and cell integrity issues in growth may be considered in terms of mass transfer, the most notable of these is oxygen transfer for aerobic growth. A maximum uptake rate of oxygen exists for any system, and the design should be based on an understanding of this limitation. Also the oxygen uptake rate of cells shows a saturation dependence on dissolved oxygen concentration ( $C_L$ ). Assuming a pseudo-steady state of dissolved oxygen concentration, a design value of gas-liquid mass transfer coefficient,  $\kappa_L\alpha$  for a biological system can be specified for a specific reactor as

$$\kappa_L\alpha \geq \frac{\text{Maximum oxygen demand}}{C_L^* - C_{L,\text{critical}}}$$

The term “critical” refers to the point in the oxygen uptake rate versus dissolved oxygen concentration plot ( $C_L$ ) at which saturation is achieved and no further oxygen can be dissolved. The gas-liquid mass transfer coefficient often changes during the course of fermentation because of changes in broth rheology or through additives, such as antifoaming agents.



### **Mixing**

Concentration and temperature are influenced by mixing in bioreactors. Total homogeneity within a system is rarely, if ever, achieved and local variations in mixing within vessels may affect growth, metabolism, or other molecular expression phenomena. Operating conditions influence terminal mixing time (time to reach designated variability associated with complete mixing) and mean circulation time (time to circulate through specific region once). Characterization of mixing times and the influence of geometric features of reactors under different operating conditions and scales of operation (bench, pilot, and full scale) are important if efficiency (time and cost) is to be optimized.

### **Heat Transfer**

Heat is dissipated mainly by convection across the walls of the jacket or coils. In aerated systems, metabolic heat production is correlated with oxygen uptake rate. The maximum metabolic load should be considered in design calculations as in gas-liquid oxygen transfer. Handbook values are available for heat transfer on the jacket side, vessel side, and in tubes. In general, heat transfer becomes a problem only in very large scale operations and in dense microbial populations, which are frequent with recombinant cells. In other cases, gas-liquid mass transfer and mixing are the major concerns.

### **Shear**

Agitation is required to maintain suspensions of the cells. Agitated bioreactors are designed to maintain complete suspension (no cell mass at the bottom of the reactor) or a homogeneous suspension. These terms imply stable flocculations (aggregates) in suspension or homogeneous cell distribution throughout the suspension.

The mechanism of shear damage to the cells is not clear. Mycelial or protozoan cells exhibit shear rate-limited growth, and cell damage has been monitored by analyzing the concentration of low-molecular-weight nucleotides in the culture broth.

## **BIOPROCESSING PLANT DESIGN**

The foregoing discussion focused on major elements of bioprocessing activities, namely water treatment and reactor design. Heating, ventilation, and air conditioning (HVAC) and steam production, described elsewhere in this text, are also requirements for bioprocessing. The design of a bioprocessing plant is subject to cGMPs, which emphasize control and reproducibility. It is clear that the application of such principles to other pharmaceutical processes of a more mechanical nature may readily be achieved. The biological nature of the processes being controlled challenges the engineers and scientists involved.

As with any regulated process, specifications must be prepared in advance and acceptance criteria established for subsequent quality control checks. Validation of the facility and process should be considered essential to design, construction, and start-up. Documentation of design and construction ensures appropriate specifications for subsequent validation.

## **PROTEIN PURIFICATION**

The purpose of bioprocess engineering is to utilize resources necessary to promote the growth of microorganisms in a controlled environment for the purpose

**TABLE 16.4** Purification Steps of Soluble Proteins

Chromatography	Adsorption ion exchange Hydrophobic interaction Cell affinity High-pressure liquid chromatography
Precipitation	Ammonium sulfate Organic solvents High-molecular-weight polymers
Extraction	Liquid-liquid Solid-liquid
Concentration	Ultrafiltration
Buffer exchange	Ultrafiltration Gel chromatography

of producing a product of biological origin. Note that additional processing is required to purify the product obtained from these systems. The purification from cell culture of soluble proteins may be conducted by combining traditional purification steps (Harrison, 1994). These steps are shown in Table 16.4. Each step focuses on particular physicochemical properties; for example, ion exchange, hydrophobic interaction, and gel chromatography separate molecules based on charge, hydrophobicity, and molecular size, respectively. Inclusion bodies with complex tertiary structures undergo additional steps, including washing, solubilizing, and refolding of proteins before further purification steps are adopted.

As with all of the foregoing processes, validation of purification steps is required. Indeed, the sequence of designing protein purification processes may be described as follows (Nelson, 1991):

- Stepwise recovery yields
- Impurity removal
- Scalability of protein purification steps
- Validation of protein purification steps

Biotechnological innovation occurs as a result of complex integrated bio-processes based on molecular and cellular biology. The key processes have been described briefly in this chapter, and discourses of some length are available on each of these topics in the literature. Since the next generation of pharmaceutical products is likely to be developed by these methods, readers are strongly encouraged to familiarize themselves with these topics and with the more fundamental issues of molecular and cellular biology not covered in this text (Bolsover et al., 1997).