

## 24

Electrolysis and  
Electrical Conductance

## CHAPTER

## CONTENTS

MECHANISM OF ELECTROLYSIS

ELECTRICAL UNITS

FARADAY'S LAWS OF  
ELECTROLYSIS

FARADAY'S FIRST LAW

FARADAY'S SECOND LAW

IMPORTANCE OF THE FIRST  
LAW OF ELECTROLYSISIMPORTANCE OF THE SECOND  
LAW OF ELECTROLYSISCONDUCTANCE OF  
ELECTROLYTES

SPECIFIC CONDUCTANCE

EQUIVALENT CONDUCTANCE

SUMMARY OF  
ELECTROCHEMICAL  
QUANTITIES

STRONG ELECTROLYTES

WEAK ELECTROLYTES

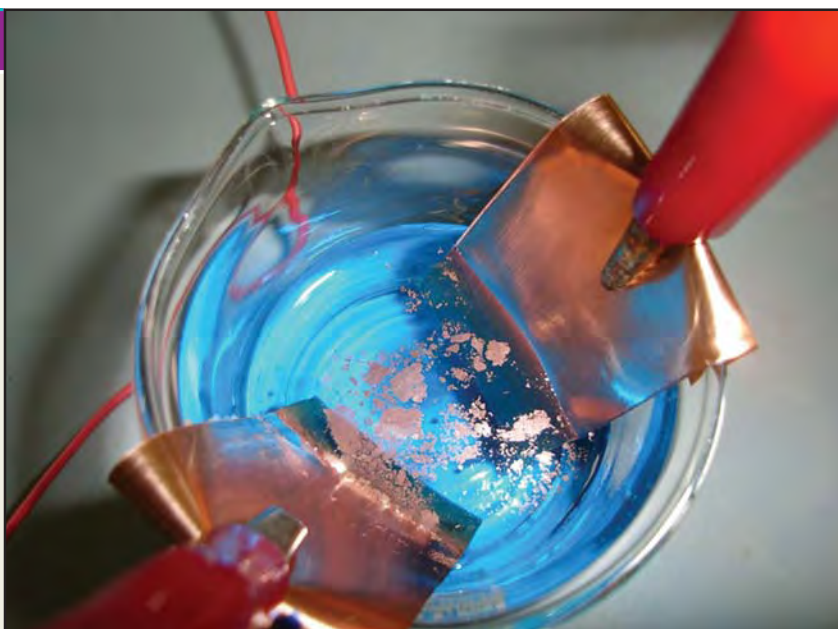
MEASUREMENT OF  
ELECTROLYTIC CONDUCTANCEDETERMINATION OF THE CELL  
CONSTANT

Water-soluble substances are distinguished as *electrolytes* or *nonelectrolytes*.

**Electrolytes are electrovalent substances that form ions in solution which conduct an electric current.** Sodium chloride, copper (II) sulphate and potassium nitrate are examples of electrolytes.

Nonelectrolytes, on the other hand, are covalent substances which furnish neutral molecules in solution. Their water-solutions do not conduct an electric current. Sugar, alcohol and glycerol are typical nonelectrolytes.

An electrolyte invariably undergoes chemical decomposition as a result of the passage of electric current through its solution.

**The phenomenon of decomposition of an electrolyte by passing electric current through its solution is termed Electrolysis** (*lyo* = breaking).

The process of electrolysis is carried in an apparatus called the **Electrolytic cell**. The cell contains water-solution of an electrolyte in which two metallic rods (electrodes) are dipped. These rods are connected to the two terminals of a battery (source of electricity). The electrode connected to the positive terminal

of the battery attracts the negative ions (anions) and is called **anode**. The other electrode connected to the negative end of the battery attracts the positive ions (cations) and is called **cathode**.

### MECHANISM OF ELECTROLYSIS

How the electrolysis actually takes place, is illustrated in Fig 24.1. The cations migrate to the cathode and form a neutral atom by accepting electrons from it. The anions migrate to the anode and yield a neutral particle by transfer of electrons to it. As a result of the loss of electrons by anions and gain of electrons by cations at their respective electrodes chemical reaction takes place.

**Example.** Let us consider the electrolysis of hydrochloric acid as an example. In solution, HCl is ionised,

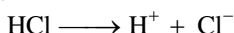

In the electrolytic cell  $\text{Cl}^-$  ions will move toward the anode and  $\text{H}^+$  ions will move toward the cathode. At the electrodes, the following reactions will take place.

At cathode :



As you see, each hydrogen ion picks up an electron from the cathode to become a hydrogen atom. Pairs of hydrogen atoms then unite to form molecules of hydrogen gas,  $\text{H}_2$ .

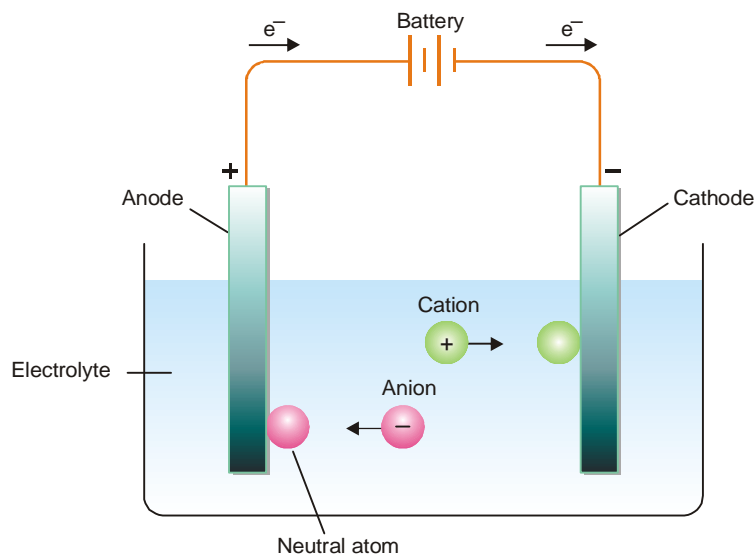

■ **Figure 24.1**  
The mechanism of electrolysis.

At Anode :



After the chloride ion loses its electron to the anode, pair of chlorine atoms unite to form chlorine gas,  $\text{Cl}_2$ .

The net effect of the process is the decomposition of HCl into hydrogen and chlorine gases. The overall reaction is :



### ELECTRICAL UNITS

There are a few electrical units which we should understand before taking up the study of quantitative aspects of electrolysis. These are :

**Coulomb**

A coulomb is a **unit quantity of electricity**. It is the amount of electricity which will deposit 0.001118 gram of silver from a 15 per cent solution of silver nitrate in a coulometer.

**Ampere**

An ampere is a **unit rate of flow of electricity**. It is that current which will deposit 0.001118 gram of silver in one second. In other words, an ampere is a current of one coulomb per second.

**Ohm**

An ohm is a **unit of electrical resistance**. It is the resistance offered at 0°C to a current by a column of mercury 106.3 cm long of about 1 sq mm cross-sectional area and weighing 14.4521 grams.

**Volt**

A volt is a **unit of electromotive force**. It is the difference in electrical potential required to send a current of one ampere through a resistance of one ohm.

**FARADAY'S LAWS OF ELECTROLYSIS**

Michael Faraday studied the quantitative aspect of electrolysis. He discovered that there exists a definite relationship between the amounts of products liberated at the electrodes and the quantity of electricity used in the process. In 1834, he formulated two laws which are known as **Faraday's Laws of Electrolysis**. These are :

**First Law**

The amount of a given product liberated at an electrode during electrolysis is directly proportional to the quantity of electricity which passes through the electrolyte solution.

**Second Law**

When the same quantity of electricity passes through solutions of different electrolytes, the amounts of the substances liberated at the electrodes are directly proportional to their chemical equivalents.

**Definition of Electrochemical equivalent in light of First Law**

If  $m$  is the mass of substance (in grams) deposited on electrode by passing  $Q$  coulombs of electricity, then

$$m \propto Q \quad (\text{First Law})$$

We know that  $Q = I \times t$

where  $I$  is the strength of current in amperes and  $t$  is the time in second for which the current has been passed.

Therefore,  $m \propto I \times t$

or  $m = Z \times I \times t$

where  $Z$  is the constant known as the Electrochemical equivalent of the substance (electrolyte).

If  $I = 1$  ampere and  $t = 1$  second, then

$$m = Z$$

Thus, **the electrochemical equivalent is the amount of a substance deposited by 1 ampere current passing for 1 second (i.e., one coulomb)**.

**The Electrical unit Faraday**

It has been found experimentally that the quantity of electricity required to liberate one gram-equivalent of a substance is 96,500 coulombs. This quantity of electricity is known as **Faraday** and is denoted by the symbol  $F$ .

It is obvious that the quantity of electricity needed to deposit 1 mole of the substance is given by the expression.

$$\text{Quantity of electricity} = n \times F$$

where  $n$  is the valency of its ion. Thus the quantity of electricity required to discharge :

$$\text{one mole of Ag}^+ = 1 \times F = 1F$$

$$\text{one mole of Cu}^{2+} = 2 \times F = 2F$$

$$\text{one mole of Al}^{3+} = 3 \times F = 3F$$

We can represent the reactions on the cathode as :

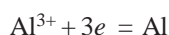
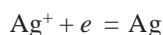

It is clear that the moles of electrons required to discharge one mole of ions  $\text{Ag}^+$ ,  $\text{Cu}^{2+}$  and  $\text{Al}^{3+}$  is one, two and three respectively. Therefore it means that the quantity of electricity in one Faraday is one mole of electrons. Now we can say that.

$$1 \text{ Faraday} = 96,500 \text{ coulombs} = 1 \text{ Mole electrons}$$

### Importance of the First law of Electrolysis

With the help of the first law of electrolysis we are able to calculate :

- (1) the value of electrochemical equivalents of different substances; and
- (2) the masses of different substances produced by passing a known quantity of electricity through their solutions.

### Verification of the Second law of Electrolysis

According to this law when the same quantity of electricity is passed through different electrolyte solutions, the masses of the substances deposited on the electrodes are proportional to their chemical equivalents.

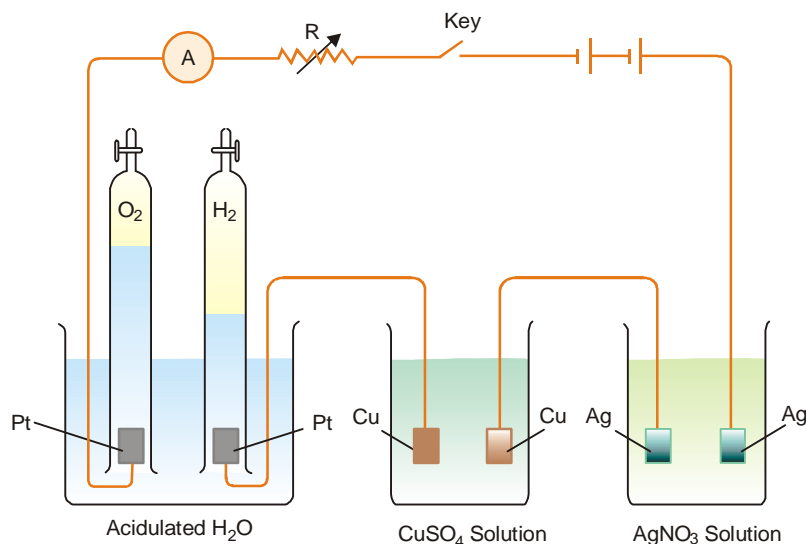

■ **Figure 24.2**  
**Illustrating Faraday's Second Law of Electrolysis.**

To verify the law, let us take an arrangement of the type shown in Fig. 24.2. Pass the same quantity of electricity through the three **coulometers** (the term 'coulometer' is now in practice

replaced by the older term 'voltmeter') containing solution of dilute  $\text{H}_2\text{SO}_4$ ,  $\text{CuSO}_4$  and  $\text{AgNO}_3$  respectively. These coulometers are fitted with platinum, copper and silver electrodes as shown in Fig. 24.2. The masses of hydrogen, copper and silver liberated/deposited at the respective cathodes are in the ratio of their equivalent weights. That is,

$$\frac{\text{mass of hydrogen liberated}}{\text{mass of copper deposited}} = \frac{\text{Eq. Wt. of hydrogen}}{\text{Eq. Wt. of copper}}$$

and

$$\frac{\text{mass of copper deposited}}{\text{mass of silver deposited}} = \frac{\text{Eq. Wt. of copper}}{\text{Eq. Wt. of silver}}$$

From this experiment, we can calculate the mass of hydrogen, copper and silver liberated at their respective cathodes by one coulomb of electricity. We find these are always :

$$\text{Hydrogen} = 0.00001036 \text{ g}$$

$$\text{Copper} = 31.78 \times 0.00001036 = 0.0003292 \text{ g}$$

$$\text{Silver} = 107.88 \times 0.00001036 = 0.001118 \text{ g}$$

Since the equivalent weights of hydrogen, copper and silver are 1, 31.78 and 107.88 respectively, it follows that **the chemical equivalents are proportional to the chemical equivalents** (or equivalent weights).

#### Importance of the Second law of Electrolysis

The second law of electrolysis helps to calculate :

- (1) the equivalent weights of metals
- (2) the unit of electric charge
- (3) the Avogadro's number

**SOLVED PROBLEM 1.** 0.1978 g of copper is deposited by a current of 0.2 ampere in 50 minutes. What is the electrochemical equivalent of copper?

#### SOLUTION

Here  $t = 50$  minutes =  $50 \times 60$  seconds;  $I = 0.2$  ampere. Quantity of electricity used is

$$Q = I \times t = 0.2 \times 50 \times 60 = 600 \text{ coulombs}$$

$$\text{Amount of copper deposited by 600 coulombs} = 0.1978 \text{ g}$$

$$\text{Amount of copper deposited by 1 coulomb} = \frac{0.1978}{600} \text{ g} = 0.0003296 \text{ g}$$

$$\therefore \text{Electrochemical equivalent of copper} = 0.0003296$$

**SOLVED PROBLEM 2.** What current strength in amperes will be required to liberate 10 g of iodine from potassium iodide solution in one hour?

#### SOLUTION

$$127 \text{ g of iodine (1 g eqvt) is liberated by} = 96,500 \text{ coulomb}$$

$$\therefore 10 \text{ g of iodine is liberated by} = \frac{96,500}{127} \times 10 \text{ coulomb}$$

$$\text{Let current strength be} = I$$

$$\text{Time in seconds} = 1 \times 60 \times 60$$

We know that the quantity of electricity,  $Q$ , used is given by the expression

$$Q = I \times \text{time in seconds}$$

$$\therefore \text{Current strength, } I = \frac{Q}{t} = \frac{96,500 \times 10}{127 \times 60 \times 60}$$

$$= 2.11 \text{ ampere}$$

**SOLVED PROBLEM 3.** An electric current is passed through three cells in series containing respectively solution of copper sulphate, silver nitrate and potassium iodide. What weights of silver and iodine will be liberated while 1.25 g of copper is being deposited?

**SOLUTION** 
$$\frac{\text{Wt. of copper}}{\text{Wt. of Iodine}} = \frac{\text{Eqvt. wt. of copper}}{\text{Eqvt. wt. of Iodine}}$$

or 
$$\frac{1.25}{x} = \frac{31.7}{127}$$

Hence 
$$x = 5.0 \text{ g of iodine}$$

Also, 
$$\frac{\text{Wt. of copper}}{\text{Wt. of silver}} = \frac{1.25}{y} = \frac{\text{Eqvt. wt. of Cu (= 31.7)}}{\text{Eqvt. wt. of silver (= 108)}}$$

$$\therefore \text{Wt. of silver (y)} = \frac{108 \times 1.25}{31.7} = 4.26 \text{ g}$$

### CONDUCTANCE OF ELECTROLYTES

We have seen that electrolyte solutions conduct electric currents through them by movement of the ions to the electrodes. The power of electrolytes to conduct electric currents is termed **conductivity** or **conductance**. Like metallic conductors, electrolytes obey Ohm's law. According to this law, the current  $I$  flowing through a metallic conductor is given by the relation.

$$I = \frac{E}{R}$$

where  $E$  is the potential difference at two ends (in volts); and  $R$  is the resistance measured in ohms (or  $\Omega$ ). The resistance  $R$  of a conductor is directly proportional to its length,  $l$ , and inversely proportional to the area of its cross-section,  $A$ . That is,

$$R \propto \frac{l}{A}$$

or 
$$R = \rho \times \frac{l}{A} \quad \dots(1)$$

where  $\rho$  "rho" is a constant of proportionality and is called **resistivity** or **specific resistance**. Its value depends upon the material of the conductor. From (1) we can write

$$\rho = R \times \frac{A}{l}$$

If  $l = 1 \text{ cm}$  and  $A = 1 \text{ sq cm}$ , then

$$\rho = R$$

Thus it follows that the **Specific resistance** of a conductor is the resistance in ohms which one centimetre cube of it offers to the passage of electricity.

### Specific Conductance

It is evident that a substance which offers very little resistance to the flow of current allows more current to pass through it. Thus the power of a substance to conduct electricity or conductivity is the converse of resistance. The reciprocal of specific resistance is termed **Specific conductance** or **Specific conductivity**.

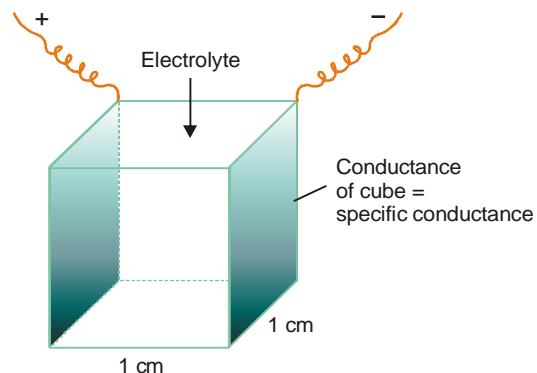

■ **Figure 24.3**  
Diagrammatic illustration of definition of specific conductance.

It is defined as : **the conductance of one centimetre cube (cc) of a solution of an electrolyte.**

The specific conductance is denoted by the symbol  $\kappa$  (kappa). Thus,

$$\kappa = \frac{1}{\rho} = \frac{1}{R} \times \frac{l}{A}$$

#### Units of Specific conductance

Specific conductance is generally expressed in reciprocal ohms (r.o) or **mhos** or **ohm<sup>-1</sup>**. Its unit can be derived as follows :

$$\begin{aligned} \kappa &= \frac{1}{A} \times \frac{l}{R} = \frac{1}{\text{ohm}} \times \frac{\text{cm}}{\text{cm}^2} \\ &= \text{ohm}^{-1}\text{cm}^{-1} \end{aligned}$$

The internationally recommended unit for ohm<sup>-1</sup> (or mho) is **Siemens, S**. When S is used, the conductance is expressed as **S cm<sup>-1</sup>**. It may be noted that Siemens is not a plural, the unit is named after Sir William Siemens—a noted electrical engineer.

The specific conductance increases with : (i) ionic concentration, and (ii) speeds of the ions concerned.

In measuring the specific conductance of the aqueous solution of an electrolyte, the volume of water in which a certain amount of the electrolyte is dissolved is always measured in cubic centimeters (cc) and this is known as **dilution**. If the volume of a solution is  $V_{cc}$ , the specific conductance of the solution is written as  $\kappa$ .

#### Equivalent Conductance

It is defined as **the conductance of an electrolyte obtained by dissolving one gram-equivalent of it in V cc of water.**

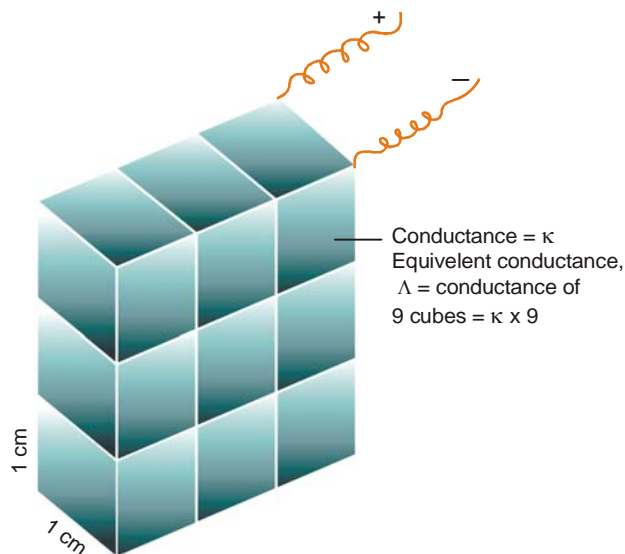

■ **Figure 24.4**  
**Solution of 1 g-eqvt. dissolved in 9 cc water between electrode plates 1 cm apart has  $L = \kappa \times 9$ .**

The equivalent conductance is denoted by  $\Lambda$ . It is equal to the product of the specific conductance,  $\kappa$  and the volume  $V$  in cc containing one gram-equivalent of the electrolyte at the dilution  $V$ .

Thus,

$$\Lambda = \kappa \times V$$

This is illustrated in Fig. 24.4. A solution having one gram-equivalent of the electrolyte dissolved in, say, 9cc water be placed between two electrodes 1 cm apart. The solution could be considered as consisting of nine cubes, each of which has a conductance  $\kappa$  (specific conductance). Thus the total conductance of the solution will be  $9 \times \kappa$ . Similarly,  $V$ cc of solution will form  $V$  cubes and the total conductance will be  $\kappa \times V$ .

In general, if an electrolyte solution contains  $N$  gram-equivalents in 1000 cc of the solution, the volume of the solution containing 1 gram-equivalent will be  $1000/N$ . Thus,

$$\Lambda = \frac{\kappa \times 1000}{N}$$

### Unit of Equivalent conductance

The unit of equivalent conductance may be deduced as follows :

$$\begin{aligned} \Lambda &= \kappa \times V \\ &= \frac{1}{R} \times \frac{l}{A} \times V \\ &= \frac{1}{\text{ohm}} \times \frac{\text{cm}}{\text{cm}^2} \times \frac{\text{cm}^3}{\text{eqvt}} \\ &= \text{ohm}^{-1} \text{cm}^2 \text{eqvt}^{-1} \end{aligned}$$

### Variation of Equivalent conductance with Concentration (or Dilution)

The equivalent conductance of a solution does not vary linearly with concentration. The effect of concentration on equivalent conductance can be studied by plotting  $\Lambda$  values against the square root of the concentration. It has been found that variation of equivalent conductance with  $\sqrt{C}$  depends upon the nature of electrolyte. Fig. 24.5 shows the behaviour of strong and weak electrolytes with change of concentration.

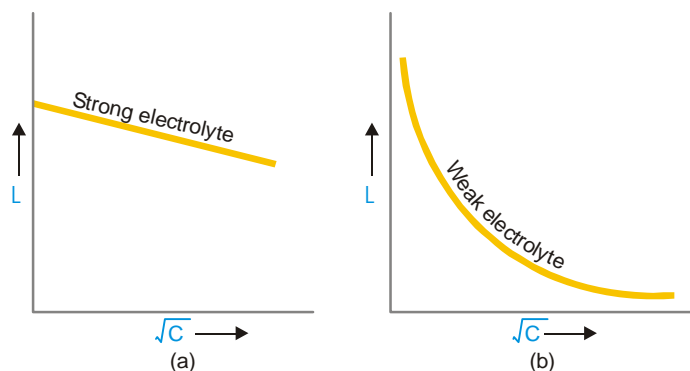

■ **Figure 24.5**  
Variation of equivalent conductivity,  $L$  with  $\sqrt{C}$  :  
(a) for strong electrolyte; (b) for weak electrolyte.

Strong electrolytes are completely ionised at all concentrations (or dilutions). The increase in equivalent conductance is not due to the increase in the number of current carrying species. This is, in fact, due to the decrease in forces of attraction between the ions of opposite charges with the decrease in concentration (or increase in dilution). At higher concentration, the forces of attraction between the opposite ions increase ( $F \propto q_1 q_2 / r^2$ ). Consequently, it affects the speed of the ions



with which they move towards oppositely charged electrodes. This phenomenon is called **ionic interference**. As the solution becomes more and more dilute, the equivalent conductance increases, till it reaches a limitary value. This value is known as equivalent conductance at infinite dilution (zero concentration) and is denoted by  $\Lambda$ .

Weak electrolytes have low ionic concentrations and hence interionic forces are negligible. Ionic speeds are not affected with decrease in concentration (or increase in dilution). The increase in equivalent conductance with increasing dilution is due to the increase in the number of current-carrier species. In other words, the degree of ionisation ( $\alpha$ ) increases. Thus **increase in equivalent conductance ( $\Lambda$ ) in case of a weak electrolyte is due to the increase in the number of ions**.

In case of a weak electrolyte  $\Lambda_\infty$  is the equivalent conductance when ionisation is complete. So, the conductance ratio  $\Lambda/\Lambda_\infty$  is the degree of ionisation. That is,

$$\alpha = \frac{\Lambda}{\Lambda_\infty}$$

**SOLVED PROBLEM 1.** 0.5 Normal solution of a salt placed between two platinum electrodes, 20 cm apart and of area of cross-section 4.0 sq cm has a resistance of 25 ohms. Calculate the equivalent conductance of the solution.

**SOLUTION**

**Calculation of specific conductance**

$$l = 20 \text{ cm} \quad A = 4.0 \text{ sq cm} \quad R = 25 \text{ ohms}$$

$$\begin{aligned} \text{Specific conductance } \kappa &= \frac{1}{R} \times \frac{l}{A} \\ &= \frac{1}{25} \times \frac{20}{4} \\ &= 0.2 \text{ ohm}^{-1} \text{ cm}^{-1} \end{aligned}$$

**Calculation of Equivalent conductance**

$$\begin{aligned} \text{Equivalent conductance} &= \kappa \times \frac{1000}{N} = \frac{0.2 \times 1000}{0.5} \\ &= 400 \text{ ohm}^{-1} \text{ cm}^2 \text{ eqvt}^{-1} \end{aligned}$$

**SOLVED PROBLEM 2.** The resistance of a N/10 solution of a salt is found to be  $2.5 \times 10^3$  ohms. Calculate the equivalent conductance of the solution. Cell constant =  $1.15 \text{ cm}^{-1}$ .

**SOLUTION**

**Calculation of Specific conductance**

$$\begin{aligned} \text{Specific conductance } \kappa &= \frac{1}{R} \times \text{cell constant} \\ &= \frac{1}{2.5 \times 10^3} \times 1.15 \end{aligned}$$

**Calculation of Equivalent conductance**

$$\begin{aligned} \text{Equivalent conductance} &= \frac{\kappa \times 1000}{N} \\ &= \frac{1.15 \times 1000}{2.5 \times 10^3 \times 0.1} = \frac{115}{25} \\ &= 4.60 \text{ ohm}^{-1} \text{ cm}^2 \text{ eqvt}^{-1} \end{aligned}$$

**Molar Concentration**

It is another quantity which helps in comparing the conductivities of electrolytes. It is defined as : **the conductance of all ions produced by one mole (one gram-molecular weight) of an electrolyte when dissolved in a certain volume V cc.**

Molar conductance is denoted by  $\mu$ . Its value is obtained by multiplying the specific conductance,  $\kappa$ , by the volume in cc containing one mole of the electrolyte.

Thus,

Molar conductance,  $\mu = \kappa \times V$  where V is the volume of the solution in cc containing one mole of the electrolyte.

**Units of Molar Concentration**

$$\begin{aligned} \text{Since } \kappa &= \frac{1}{R} \times \frac{l}{A} \\ \mu &= \frac{1}{R} \times \frac{l}{A} \times V \\ &= \frac{1}{\text{ohm}} \times \frac{\text{cm}}{\text{cm}^2} \times \frac{\text{cm}^3}{\text{mol}} \\ &= \text{ohm}^{-1} \text{ cm}^2 \text{ mol}^{-1} \end{aligned}$$

**Calculation of Molar conductance**

Molar conductance can be calculated by using the relation :

$$\mu = \frac{\kappa \times 1000}{M}$$

where  $M$  is the number of moles of the electrolyte present in 1000 cc of solution.

**Upon dilution specific conductance decreases, while Equivalent conductance and Molar conductance increases.**

It is important to note that specific conductance decreases with dilution. It is the conductance of one cc of the solution. Upon diluting the solution, the concentration of ions per cc decreases. Hence the specific conductance falls. On the other hand, the equivalent and molar conductance show an increase as these are the products of specific conductance and the volume of the solution containing one gram-equivalent or one mole of the electrolyte respectively. With dilution, the first factor decreases, while the other increases. The increase in the second factor is much more than the decrease in the first factor. The specific and molar conductance of NaCl solution at 18°C are shown in Table 24.1.

**TABLE 24.1. SPECIFIC AND MOLAR CONDUCTANCE OF NaCl SOLUTION AT 18°C**

Volume, V in cc containing 1 g mol	Specific conductance, $\text{ohm}^{-1} \text{ cm}^2 \text{ eqvt}^{-1}$	Molar conductance $\text{ohm}^{-1} \text{ cm}^2 \text{ mol}^{-1}$
1,000	0.0744	74.4
5,000	0.01760	88.2
20,000	0.0479	95.9
500,000	0.000213	106.7
1,000,000	0.0001078	107.3
2,000,000	0.0000542	108.5
5,000,000	0.0000218	109.2
10,000,000	0.00001097	109.7

The equivalent conductance of some common electrolytes at 18°C is given in Table 24.2.

Volume, V in cc containing 1 g equivalent	Equivalent conductance $\Lambda$ , $\text{ohm}^{-1} \text{cm}^2 \text{eqvt}^{-1}$				
	NaOH	KCl	HCl	CH <sub>3</sub> COOH	CH <sub>3</sub> COONa
1,000	160	98.3	301	1.32	41.2
2,000	172	120.4	327	2.01	49.4
10,000	183	112.0	351	4.60	61.1
20,000	190	115.9	360	6.48	64.2
100,000	200	122.4	370	14.3	70.2
200,000	203	124.4	372	20.0	72.4
500,000	206	126.3	376	30.2	74.3
	210	127.3	377	41.0	75.2

### Summary of Electrochemical Quantities

A summary of the electrochemical terms, their symbols and units in which they are expressed are listed in Table 24.3 for reference.

Quantity	Symbol	Unit
Resistance	$R$	ohm or $\Omega$
Resistivity or Specific resistance	$\rho$ (rho)	ohm cm
Conductance	$1/R$	$\text{ohm}^{-1}$ or Siemens
Specific conductance	$\kappa$ (kappa)	$\text{ohm}^{-1} \text{cm}^{-1}$
Dilution	$V$	cc
Equivalent conductance	$\Lambda$	$\text{ohm}^{-1} \text{cm}^2 \text{eqvt}^{-1}$
Molar conductance	$\mu$	$\text{ohm}^{-1} \text{cm}^2 \text{mol}^{-1}$

### Variation of Conductance with Temperature

The conductance of a solution of an electrolyte generally increases with rise in temperature. It has been found by experiment that the conductance of a given solution increases by 2-3 per cent for one degree rise in temperature. For example, the conductances of 0.1 M KCl at two different temperatures are

$$1.12 \times 10^{-2} \text{ohm}^{-1} \text{cm}^{-1} \text{ at } 18^\circ\text{C}$$

$$1.29 \times 10^{-2} \text{ohm}^{-1} \text{cm}^{-1} \text{ at } 25^\circ\text{C}$$

The conductance of a given electrolyte depends on two factors :

- (1) The number of ions present in unit volume of solution
- (2) The speed at which ions move towards the electrodes

At a given temperature, the first factor remains the same for a particular electrolyte. Thus the increase in conductance with rise in temperature is due to the influence of factor (2). With rise in temperature the viscosity of the solvent (water) decreases which makes the ions to move freely toward the electrodes.

For weak electrolytes, the influence of temperature on conductance depends upon the value of  $\Delta H$  accompanying the process of ionisation. If the ionisation is exothermic ( $-\Delta H$ ), the degree of ionisation is less at higher temperature (Le Chatelier's principle) and conductance decreases. Conversely, if the ionisation is endothermic ( $+\Delta H$ ), the degree of ionisation is more at higher temperature and conductance increases.

### STRONG AND WEAK ELECTROLYTES

Electrolytes may be divided into two classes :

- (a) Strong electrolytes
- (b) Weak electrolytes

#### Strong Electrolytes

A strong electrolyte is a substance that gives a solution in which almost all the molecules are ionised. The solution itself is called a **strong electrolytic solution**. Such solutions are good conductors of electricity and have a high value of equivalent conductance even at low concentrations. The strong electrolytes are :

- (1) **The strong acids** *e.g.*, HCl,  $H_2SO_4$ ,  $HNO_3$ ,  $HClO_4$ , HBr and HI.
- (2) **The strong bases** *e.g.*, NaOH, KOH,  $Ca(OH)_2$ ,  $Mg(OH)_2$ , etc.
- (3) **The salts**. Practically all salts (NaCl, KCl, etc) are strong electrolytes.

#### Weak Electrolytes

A weak electrolyte is a substance that gives a solution in which only a small proportion of the solute molecules are ionised. Such a solution is called a **weak electrolytic solution**, that has low value of equivalent conductance. The weak electrolytes are :

- (1) **The weak acids** : All organic acids such as acetic acid, oxalic acid, sulphurous acid ( $H_2SO_3$ ) are examples of weak electrolytes.
- (2) **The weak bases** : Most organic bases *e.g.*, alkyl amines ( $C_2H_5NH_2$ ) are weak electrolytes.
- (3) **Salts**. A few salts such as mercury (II) chloride and lead (II) acetate are weak electrolytes.

#### Measurement of Electrolytic conductance

We know that conductance is the reciprocal of resistance. Therefore it can be determined by measuring the resistance of the electrolytic solution. This can be done in the laboratory with the help of a **Wheatstone bridge**.

The solution whose conductance is to be determined is placed in a special type of cell known as the **conductance cell**.

A simple type of conductance cell used in the laboratory is shown in Fig. 24.6. The electrodes fitted in the cell are made of platinum plates coated with platinum black. These are welded to platinum wires fused in two thin glass tubes. The contact with copper wires of the circuit is made by dipping them in mercury contained in the tubes.

The arrangement commonly used for the measurement of resistance of the conductance cell is shown in Fig. 24.7. It may be noted that a *head-phone* is used in place of a galvanometer. AB is a manganin wire tightly stretched over a meter rule graduated in millimeters. A sliding contact H (shown by arrow-head) moves along this wire. R is a

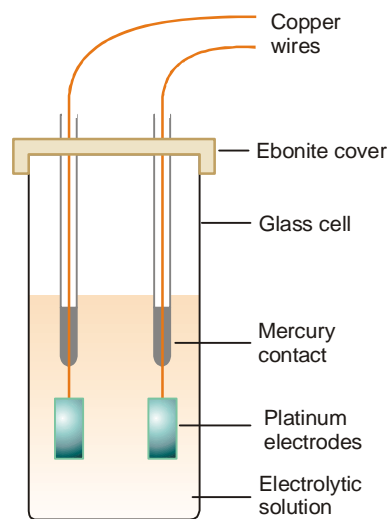

■ **Figure 24.6**  
A Conductance cell.

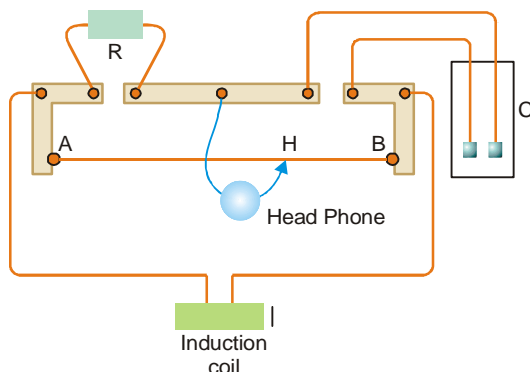

■ **Figure 24.7**  
Apparatus for Conductance measurement.

resistance box. C is the conductance cell containing electrolytic solution. I is the induction coil from which alternating current is led as shown in the diagram. When the current is flowing, any resistance is unplugged in the resistance box R. The sliding contact H is moved until the sound in the head-phone is minimum. When this occurs, we have

$$\frac{\text{resistance of C}}{\text{resistance of R}} = \frac{\text{resistance BH}}{\text{resistance AH}} = \frac{\text{length BH}}{\text{length AH}}$$

$$\text{or} \quad \text{resistance of C} = \frac{\text{length BH}}{\text{length AH}} \times \text{resistance R}$$

The resistance of a solution in the conductance cell as measured above can be converted to specific conductance by using the equation

$$\kappa = \frac{1}{R} \times \frac{l}{A} \quad \dots(1)$$

$$\text{or} \quad \kappa = \frac{1}{R} \times x \quad \dots(2)$$

The ratio  $l/A$  has been put equal to  $x$ . That is,

$$\frac{\text{distance between electrodes}}{\text{area of electrode}} = x \text{ (cell constant)}$$

The value of  $x$  is the same for a given cell and is called the **cell constant**.

After determining the specific conductance,  $\kappa$ , the equivalent conductance,  $\Lambda$ , and the molar conductance of the solution can be calculated by using the expressions.

$$\Lambda = \frac{\kappa \times 1000}{N}$$

$$\mu = \frac{\kappa \times 1000}{M}$$

where  $N$  is the gram-equivalent and  $M$  is the gram-mole of the electrolyte.

#### Determination of the Cell constant

The exact value of the cell constant ( $l/A$ ) can be determined by measuring the distance between the electrodes ( $l$ ) and their area of cross sections ( $A$ ). Actual measurement of these dimensions is very difficult. Therefore an indirect method is employed to determine the value of cell constant.

We know that :

$$\text{specific conductance } \kappa = \frac{1}{R} \times \frac{l}{A}$$

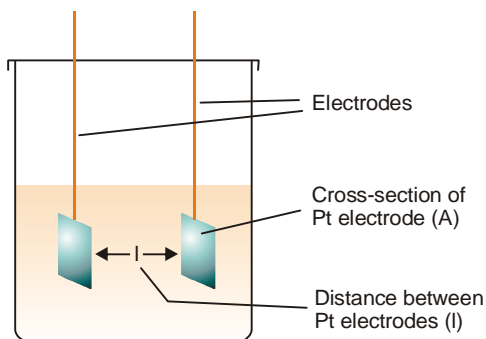

■ **Figure 24.8**  
Dimensions of a Conductance cell.

or  $\kappa = \text{observed conductance} \times \text{cell constant}$

$$\therefore \text{cell constant, } x = \frac{\text{specific conductance}}{\text{observed conductance}}$$

To determine the cell constant, a standard solution of KCl whose specific conductance at a given temperature is known, is used. Then a solution of KCl of the same strength is prepared and its conductance determined experimentally at the same temperature. Substituting the two values in the above expression, the cell constant can be calculated.

For example, according to Kohlrausch the specific conductance of N/50 solution at 25°C is 0.002765 mho. Now, an N/50 solution of KCl is prepared by dissolving 0.372 g pure KCl in 250 cc 'extra-pure' water (conductance water) and its conductance determined at 25°C. The cell constant is then calculated by substituting the observed conductance in the expression

$$\text{cell constant} = \frac{0.002765}{\text{observed conductance}}$$

**SOLVED PROBLEM 1.** The specific conductance of an N/50 solution of KCl at 25°C is 0.002765 mho. If the resistance of a cell containing this solution is 400 ohms, what is the cell constant?

**SOLUTION**

$$\begin{aligned} \text{cell constant, } x &= \frac{0.002765}{\text{observed conductance}} \\ &= 0.002765 \times \text{resistance} \\ &= 0.002765 \times 400 \\ &= \mathbf{1.106} \end{aligned}$$

**SOLVED PROBLEM 2.** The resistance of decinormal solution of a salt occupying a volume between two platinum electrodes 1.80 cm apart and 5.4 cm<sup>2</sup> in area was found to be 32 ohms. Calculate the equivalent conductance of the solution.

**SOLUTION**

Here  $l = 1.80 \text{ cm}$  and  $A = 5.4$

$$\therefore \text{cell constant } x = \frac{l}{A} = \frac{1.80}{5.4} = \frac{1}{3}$$

$$\text{observed conductance} = \frac{1}{32} \text{ mhos}$$

Since the solution is N/10,  $V = 10,000 \text{ ml}$

Now, specific conductance =  $x \times \text{obs. conductance}$

$$\kappa = \frac{1}{3} \times \frac{1}{32} = \frac{1}{96} \text{ mhos}$$

or

$$\Lambda = \kappa \times V$$

$$= \frac{1}{96} \times 10,000$$

$$= \mathbf{104.1 \text{ mhos cm}^2 \text{ equiv}^{-1}}$$

**SOLVED PROBLEM 3.** A conductance cell on being filled with a 0.02 molar solution of KCl at 25°C showed a resistance of 165 ohms. The specific conductance of the KCl solution used is  $2.77 \times 10^{-3} \text{ mho cm}^{-1}$ . The same cell containing 0.01 molar NaCl solution gave an electrical resistance of 384 ohms. Calculate the specific and equivalent conductance of the NaCl solution.

**SOLUTION:** cell constant =  $\frac{\text{specific conductance}}{\text{observed conductance}}$

Given conductance of KCl =  $2.77 \times 10^{-3} \text{ mho cm}^{-1}$

Observed conductance of KCl =  $\frac{1}{165} \text{ mho}$

$\therefore$  cell constant =  $\frac{2.77 \times 10^{-3}}{1/165} = 0.45705 \text{ cm}^{-1}$

specific conductance of NaCl = cell constant  $\times$  obs. conductance

$$= 0.45705 \times 1/384 = 1.1902 \times 10^{-3} \text{ ohm}^{-1} \text{ cm}^{-1}$$

$\therefore$  Eqvt conductance of NaCl =  $\frac{\text{sp. conductance} \times 1000}{N}$

$$= \frac{1.1902 \times 10^{-3} \times 1000}{0.01}$$

$$= \mathbf{119.02 \text{ ohm}^{-1} \text{ cm}^2 \text{ eqvt}^{-1}}$$

## EXAMINATION QUESTIONS

- Define or explain the following terms :
 

(a) Electrolysis	(b) Coulomb
(c) Faraday's laws of electrolysis	(d) Specific conductance
(e) Equivalent conductance	(f) Molar conductance
(g) Degree of Dissociation	(h) Cell constant
- Define specific and molar conductance.
  - In a particular cell, 0.01 M solution of KCl gave a resistance of 15.0 ohms at 298 K while 0.01 M solutions of HCl gave a resistance of 51.4 ohm at the same temperature. If the specific conductance of 0.01 M KCl is  $0.1409 \text{ S m}^{-1}$  at 280 K, calculate the cell constant, specific conductance and equivalent conductance of the HCl solution.

**Answer.** 21.13;  $41.10 \text{ ohm}^{-1} \text{ cm}^{-1}$ ;  $4110 \text{ ohm}^{-1}$

- The specific conductance of N/5 KCl solution at 25°C is 0.002780 mho. The resistance of the cell containing this solution is 500 ohm. Calculate cell constant.

**Answer.** 1.39

4. If equivalent conductance at infinite dilution of NaCl, HCl and  $\text{CH}_3\text{COONa}$  are 126.45, 426.16 and 91.0 respectively, find the equivalent conductance of acetic acid at infinite dilution.  
**Answer.**  $390.71 \text{ ohm}^{-1}$
5. The equivalent conductance of ammonium chloride at infinite dilution is 149.7 mho; for sodium hydroxide it is 247.8 mho; and for sodium chloride is 126.45 mho at  $25^\circ\text{C}$ . Calculate the equivalent conductance for ammonium hydroxide in mho at infinite dilution at the same temperature.  
**Answer.**  $271.05 \text{ ohm}^{-1}$
6. The resistance of a 0.5 N solution of an electrolyte occupying a volume between two platinum electrodes which are 1.72 cm apart and have an area of 4.5 sq cm is 25 ohms. Calculate the equivalent conductance of the solution.  
**Answer.**  $30.75 \text{ ohm}^{-1} \text{ cm}^2 \text{ eqvt}^{-1}$
7. State and explain Faraday's laws of Electrolysis. Following results were obtained by conductance measurements of potassium sulphate using the cell with cell constant 0.2281. The observed conductance of potassium sulphate solution is  $3 \times 10^{-3}$  mhos. The equivalent conductance of potassium sulphate solution is 140 mhos  $\text{cm}^2$ . Calculate the concentration of potassium sulphate solution.  
**Answer.** 0.0048 N
8. How is the specific conductance of an electrolyte solution determined? Describe the experimental method.  
 The resistance of a N/100 solution of an electrolyte was found to be 210 ohm at  $25^\circ\text{C}$ . Calculate the equivalent conductance of the solution at  $25^\circ\text{C}$ . (Cell constant = 0.88)  
**Answer.**  $419 \text{ ohm}^{-1} \text{ cm}^2 \text{ eqvt}^{-1}$
9. A conductance cell had a resistance of 165 ohms when filled with 0.02 molar KCl solution at  $25^\circ\text{C}$ . For such solution specific conductance is 0.00277 mhos/cm. The same cell filled with 0.01 molar NaCl had a resistance of 384 ohms. Calculate specific conductance and equivalent conductance of solution.  
**Answer.**  $1.902 \times 10^{-3} \text{ ohm}^{-1} \text{ cm}^{-1}$ ;  $119 \text{ ohm}^{-1} \text{ cm}^2 \text{ eqvt}^{-1}$
10. The conductance of N/10  $\text{AgNO}_3$  solution taken in a cell with cell constant  $0.9555 \text{ cm}^{-1}$  is  $0.0099 \text{ ohm}^{-1}$ . Calculate :  
 (a) Specific conductance (b) Equivalent conductance  
**Answer.** (a)  $0.00946 \text{ mho-cm}^{-1}$ ; (b)  $94.59 \text{ mhos cm}^2 \text{ eqvt}^{-1}$
11. The resistance of a cell containing 0.02 M KCl solution at  $25^\circ\text{C}$  was found to be 175 ohms. The specific conductance of this solution is  $27.7 \times 10^{-4} \text{ ohm}^{-1} \text{ cm}^{-1}$  at  $25^\circ\text{C}$ . An exactly 0.01 M solution of another substance in the same cell had a resistance of 579 ohms. Calculate the equivalent conductance of this substance.  
**Answer.**  $83.72 \text{ ohm}^{-1} \text{ cm}^2 \text{ eqvt}^{-1}$
12. What is cell constant? How is it determined experimentally? The specific conductance of N/50 KCl solution is  $0.002765 \text{ ohm}^{-1} \text{ cm}^{-1}$  at  $25^\circ\text{C}$ . If the resistance of the solution contained in the cell is 100 ohms, calculate the cell constant.  
**Answer.**  $0.2765 \text{ cm}^{-1}$
13. Define equivalent conductance and give its units. (Guru Nanak Dev BSc, 2000)
14. Define conductance, specific conductance, equivalent conductance and molar conductance. (Himachal Pradesh BSc, 2000)
15. Explain the factors affecting the conductance of an electrolyte. (Punjabi BSc, 2001)
16. Define specific conductance and equivalent conductance. Derive the relationship between them. (Himachal Pradesh BSc, 2001)
17. Calculate equivalent conductivity from the following data :  
 (i) 0.1 N solution has a resistance of  $2.5 \times 10^2$  ohms  
 (ii) Cell constant =  $1.15 \text{ cm}^{-1}$   
**Answer.**  $46 \text{ ohm}^{-1} \text{ cm}^2 \text{ eqvt}^{-1}$  (Andhra BSc, 2002)



18. (a) Write a short note on variation of equivalent conductance with dilution.  
 (b) Write down the methods for determination of equivalent conductance at infinite dilution for strong and weak electrolytes.  
 (c) How would you measure the conductivity of an aqueous salt solution. (Aligarh BSc, 2002)
19. Explain the difference between molecular and equivalent conductance of a solution. What are the units for the two terms. (Delhi BSc, 2002)
20. "On progressive dilution, specific conductance of an electrolyte decreases but molar conductance increases" discuss. (Arunachal BSc, 2002)
21. Define specific conductance, conductivity, equivalent conductivity and molar conductivity. What are the relations between them? What effect do they produce upon dilution? (HS Gaur BSc, 2002)
22. Describe the applications of conductance measurements. (Allahabad BSc, 2002)
23. Show that:

$$\text{Equivalent conductance} = \text{specific conductance} \times \frac{1000}{C}$$

where 'C' is concentration in g eqvt. per litre. (Allahabad BSc, 2002)

24. 0.5 N solution of a salt surrounding two platinum electrodes 2.1 cm apart and 2.4 square cm in area was found to offer a resistance of 250 ohms. Calculate the equivalent conductance of the solution.  
**Answer.** 7.0 ohm<sup>-1</sup> cm<sup>2</sup> eqvt<sup>-1</sup> (Arunachal BSc, 2003)
25. Using the plot of molar conductance versus concentration of the solution, discuss how the molar conductance at infinite dilution of the solution can be obtained. (Kalyani BSc, 2003)
26. The resistance of 0.1 N solution of an electrolyte in a cell of cell constant 0.84 cm<sup>-1</sup> is 60 ohm. Calculate the resistivity of the cell.  
**Answer.** 71.428 ohm cm<sup>-1</sup> (Sambalpur BSc, 2003)
27. Define equivalent conductance and molar conductance. Establish the relation between specific conductance and equivalent conductance. (Kalyani BSc, 2003)
28. The molar conductance of a solution of aluminium chloride is found to be 130 ohm cm<sup>2</sup> mol<sup>-1</sup> at 298 K. What would be its equivalent conductance at the same temperature.  
**Answer.** 43.33 ohm<sup>-1</sup> cm<sup>2</sup> eqvt<sup>-1</sup> (Sambalpur BSc, 2003)
29. The conductivity of a solution containing 1 g of anhydrous BaCl<sub>2</sub> in 200 cm<sup>3</sup> of water has been found to be 0.0058 ohm<sup>-1</sup> cm<sup>-1</sup>. What is the  
 (i) Molar conductance and  
 (ii) Equivalent conductance of the solution? (Atomic mass of Ba = 137 and Cl = 35.5)  
**Answer.** 241.66 ohm<sup>-1</sup> cm<sup>2</sup> mol<sup>-1</sup>; 120.83 ohm<sup>-1</sup> cm<sup>2</sup> eqvt<sup>-1</sup> (Arunachal BSc, 2004)
30. (a) Define (i) Specific conductance (ii) Equivalent conductance (iii) Molecular conductance and (iv) Cell constant. Give their units.  
 (b) Find specific conductivity of the solution if 0.5 solution of a salt occupying a volume between two Pt electrodes 1.72 cm apart and of area 4.5 sq cm has a resistance of 15 ohms.  
**Answer.** (b) 0.02548 ohm<sup>-1</sup> cm<sup>-1</sup> (Delhi BSc, 2004)
31. 0.5 N NaCl is placed between two electrodes 1.5 cm apart and having an area of each 3.0 sq cm offered a resistance of 25.0 ohms. Calculate the equivalent conductance.  
**Answer.** 40 ohm<sup>-1</sup> cm<sup>2</sup> eqvt<sup>-1</sup> (Andhra BSc, 2004)
32. The resistance of an N/10 solution is found to be 2.5 × 10<sup>3</sup> ohms. Calculate the equivalent conductance of the solution. Cell constant = 1.15 cm<sup>-1</sup>.  
**Answer.** 4.60 ohm<sup>-1</sup> cm<sup>2</sup> eqvt<sup>-1</sup> (Shivaji BSc, 2004)
33. (a) Define Molar, Equivalent and Specific conductance and discuss the effect of dilution.  
 (b) Resistance of 0.01 M aqueous solution of an electrolyte at room temperature is 420 ohm and cell constant is 0.80 cm<sup>-1</sup>. Calculate the Molar conductance.  
**Answer.** (b) 200 ohm<sup>-1</sup> m<sup>2</sup> mol<sup>-1</sup> (Madras BSc, 2004)
34. When molten lithium chloride, LiCl, is electrolysed, lithium metal is liberated at the cathode. How many

grams of lithium are liberated when  $500^{\circ}\text{C}$  of charge passes through the cell ?

**Answer.** 0.360 g (Sambalpur BSc, 2005)

35. Calculate the quantity of electricity that will be required to produce 355 g chlorine gas by the electrolysis of a concentrated solution of NaCl. Also calculate the volume of hydrogen gas liberated at  $27^{\circ}\text{C}$  and 1 atm pressure during the process.

**Answer.** 10 F ; 123.07 lit (Andhra BSc, 2005)

36. Specific conductance of 0.1 N solution of an electrolyte is  $0.02 \text{ ohm}^{-1}\text{cm}^{-1}$ . Calculate its equivalent conductance.

**Answer.**  $200 \text{ ohm}^{-1}\text{cm}^2\text{eqvt}^{-1}$  (Agra BSc, 2005)

37. A solution of copper sulphate weighing 20g was electrolysed using 0.02 Faraday of electricity. Calculate the weight of the resulting solution.

**Answer.** 9.205 g (Madurai BSc, 2005)

38. Specific conductance of 0.02 N KCl at 298 K is  $0.002768 \text{ ohm}^{-1}$  and it has resistance of 500 ohms. An 0.25 N solution of another salt kept in the same cell was found to have resistance of 300 ohms at 298 K. Calculate the cell constant and equivalent conductance of the salt solution.

**Answer.** 1.384;  $18.45 \text{ ohm}^{-1}\text{cm}^2\text{eqvt}^{-1}$  (Vidyasagar BSc, 2006)

39. A current 4.0 amperes is passed for 8 hours between nickel electrodes in 500 ml of 2M solution of nickel nitrate. What will be the molarity of the solution at the end of electrolysis ?

**Answer.** 0.806 M (Burdwan BSc, 2006)

### MULTIPLE CHOICE QUESTIONS

1. One faraday of electricity is passed through an HCl electrolyte solution. Select the correct electrode result.

- (a) 1 gram of chloride ions is deposited at the anode  
 (b) 1 gram of hydrogen ions is deposited at the cathode  
 (c) 5 grams of hydrogen ions are deposited at the anode  
 (d) 35 grams of chloride ions are deposited at the anode

**Answer.** (b)

2. One faraday will oxidize \_\_\_\_\_ mole(s) of Cu to  $\text{Cu}^{2+}$  ions.

- (a) 0 (b) 1/2  
 (c) 1/4 (d) 1

**Answer.** (b)

3. How much time (in hours) is required to plate out 25.0 g of gold metal from a solution of  $\text{Au}(\text{NO}_3)_3$  when the current is 2.00 amperes and the electrode efficiency is only 65%?

- (a) 9.36 hr (b) 2.88 hr  
 (c) 3.11 hr (d) 7.85 hr

**Answer.** (d)

4. How many faradays of charge are required to electroplate 127 g of copper from a 2 M cuprous chloride solution?

- (a) 1 (b) 2  
 (c) 4 (d) 6

**Answer.** (d)

5. Cu metal displaces  $\text{Ag}^+(\text{aq})$  from an aqueous solution. Which of the following is correct?

- (a) Ag is a better reducing agent than Cu      (b)  $\text{Ag}^+$  is easier to reduce than  $\text{Cu}^{2+}$   
(c)  $\text{Cu}^{2+}$  is a better oxidizing agent than  $\text{Ag}^+$       (d) Ag is easier to oxidize than Cu

**Answer.** (b)

6. Predict the products from the electrolysis of aqueous silver sulfate.

- (a) silver metal and sulfur      (b) hydrogen and oxygen  
(c) hydrogen and sulfur      (d) silver metal and oxygen

**Answer.** (d)

7. Which of these metals will not dissolve in hydrochloric acid under standard conditions?

- (a) zinc      (b) aluminium  
(c) copper      (d) magnesium

**Answer.** (c)

8. Which two of the following metals do not react with  $\text{HCl}(\text{aq})$ ?

Mg, Ag, Zn, Fe, Au

- (a) Ag and Zn      (b) Mg and Fe  
(c) Ag and Au      (d) Zn and Mg

**Answer.** (c)

9. What mass in grams of copper will be deposited from a solution of  $\text{Cu}^{2+}$  by a current of 2.50 A in 2.00 hr?

- (a) 23.7      (b) 0.187  
(c) 1.65      (d) 5.93

**Answer.** (d)

10. How many ml of  $\text{H}_2(\text{g})$ , measured at STP, are produced at a platinum cathode in the electrolysis of  $\text{H}_2\text{SO}_4(\text{aq})$  by 2.45 A of electric current in 5.00 min?

- (a)  $7.70 \times 10^{-3}$  ml  $\text{H}_2$       (b) 85.4 ml  $\text{H}_2$   
(c) 171 ml  $\text{H}_2$       (d) 1.42 ml  $\text{H}_2$

**Answer.** (b)

11. In the electrolysis of aqueous NaCl, how many liters of  $\text{Cl}_2(\text{g})$  (at STP) are generated by a current of 7.50 A for a period of 100 min?

- (a) 10.4 L      (b) 45000 L  
(c) 5.22 L      (d) 0.466 L

**Answer.** (c)

12. What volume (in litres) of dry oxygen gas (at STP) could be generated at the anode by the electrolysis of water over a 6.0 hour period with a current of 1.5 amperes?

- (a) 1.9 L      (b) 2.1 L  
(c) 2.5 L      (d) 3.2 L

**Answer.** (a)

13. Among lead, iron, chromium, and copper, the least easily oxidized metal is

- (a) chromium      (b) copper  
(c) iron      (d) lead

**Answer.** (b)

14. Select the incorrect statement among the following :

- (a) gold is the least active metal      (b) iron will replace manganese in a compound  
(c) potassium is most easily oxidized      (d) silver is relatively unreactive

**Answer.** (b)

15. Select the incorrect statement about the chemical activity at electrodes during electrolysis.

- (a) anions give up electrons      (b) cations take up electrons



- (a) 5.9 g (b)  $1.8 \times 10^4$  g  
 (c)  $9.3 \times 10^{-2}$  g (d) 11.9 g

**Answer.** (a)

25. Chromium metal can be produced from an acidic solution of chromate,  $\text{CrO}_4^{2-}$ .

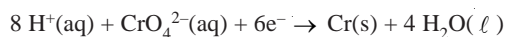

How many grams of chromium can be produced by the passage of 1 Amp for 10 hours?

Faraday constant :  $1 \text{ F} = 96,485 \text{ C/mol}$ . molar atomic mass (Cr) = 51.996 g/mol.

- (a) 0.40 g (b) 3.23 g  
 (c) 19.4 g (d) 40.8 g

**Answer.** (b)

26. Specific conductance is the conductance of

- (a) one centimeter cube of solution of an electrolyte  
 (b) one centimeter cube of a solid electrolyte  
 (c) one gram of the solution of an electrolyte  
 (d) one gram of the solid electrolyte

**Answer.** (a)

27. The units of specific conductance are

- (a) ohm cm (b) ohm  $\text{cm}^{-1}$   
 (c) ohm $^{-1}$  cm (d) ohm $^{-1}$   $\text{cm}^{-1}$

**Answer.** (d)

28. The equivalent conductance of a solution of an electrolyte

- (a) increases with dilution (b) decreases with dilution  
 (c) does not vary with dilution (d) none of these

**Answer.** (a)

29. The units of equivalent conductance are

- (a) ohm cm eqvt (b) ohm $^{-1}$   $\text{cm}^{-1}$  eqvt $^{-1}$   
 (c) ohm $^{-1}$   $\text{cm}^2$  eqvt $^{-1}$  (d) ohm $^{-1}$   $\text{cm}^{-2}$  eqvt $^{-1}$

**Answer.** (c)

30. The molar conductance of solution of an electrolyte is measured in

- (a) ohm cm mol $^{-1}$  (b) ohm $^{-1}$   $\text{cm}^{-1}$  mol $^{-1}$   
 (c) ohm  $\text{cm}^{-1}$  mol $^{-1}$  (d) ohm $^{-1}$   $\text{cm}^2$  mol $^{-1}$

**Answer.** (d)

31. With rise in temperature the conductance of a solution of an electrolyte generally

- (a) decreases (b) increases  
 (c) remains constant (d) none of these

**Answer.** (b)

32. The cell constant can be obtained by

- (a) dividing specific conductance by observed conductance  
 (b) dividing observed conductance by specific conductance  
 (c) multiplying specific conductance by observed conductance  
 (d) multiplying specific conductance by equivalent conductance

**Answer.** (a)

33. The cell constant is the ratio of

- (a) distance between electrodes to area of electrode  
 (b) area of electrode to distance between electrodes

- (c) specific conductance to area of electrode  
 (d) specific conductance to distance between the electrodes

**Answer.** (d)

34. When electricity is passed through acidulated water, 224 ml of hydrogen gas at STP is collected at the cathode in 965 sec. The current passed in ampere is  
 (a) 0.5 (b) 1.0  
 (c) 1.5 (d) 2.0

**Answer.** (d)

35. What weight of copper will be deposited by passing 1 Faraday of electricity through cupric salt?  
 (a) 3.175 g (b) 2.0 g  
 (c) 63.5 g (d) 31.75 g

**Answer.** (d)

36. Which out of the following will decompose on passing electric current?  
 (a) glucose (b) urea  
 (c) silver nitrate (d) ethyl alcohol

**Answer.** (c)

37. An ion is reduced to the element when it absorbs  $6 \times 10^{19}$  electrons. The number of equivalents of the ion is  
 (a) 0.0001 (b) 0.001  
 (c) 0.01 (d) 0.1

**Answer.** (a)

38. On passing 0.1 Faraday of electricity through  $\text{AlCl}_3$ , the amount of aluminium metal deposited on the cathode is (at mass of Al = 27)  
 (a) 0.27 g (b) 0.81 g  
 (c) 0.9 g (d) 13.5 g

**Answer.** (c)

39. When 96500 coulombs of electricity is passed through an aqueous solution of Nickel Chloride (at mass of Ni = 58.5) the weight of nickel metal deposited would be  
 (a) 5.85 g (b) 29.25 g  
 (c) 58.5 g (d) 117 g

**Answer.** (b)

40. The equivalent weight of a metal is given by

(a) $\frac{c \times t \times 96500}{m}$	(b) $\frac{96500 \times m}{c \times t}$
(c) $\frac{c \times m}{t \times 96500}$	(d) $\frac{c \times t}{m \times 96500}$

**Answer.** (b)

41. Two electrolytic cells, one containing Cuprous chloride and the other Cupric chloride, are connected in series. The ratio of ions deposited at cathodes in two cells when electricity is passed through the cells will be  
 (a) 1:1 (b) 1:2  
 (c) 2:1 (d) 1:3

**Answer.** (c)

42. On passing 96500 coulombs of electricity through a dilute solution of an acid, the volume of hydrogen collected at STP is

- (a) 1120 ml (b) 11200 ml  
(c) 2240 ml (d) 22400 ml

**Answer.** (b)

43. A solution of sodium sulphate in water is electrolysed using platinum electrodes. The products at anode and cathode respectively are

- (a)  $\text{SO}_2, \text{O}_2$  (b)  $\text{Na}, \text{O}_2$   
(c)  $\text{H}_2, \text{O}_2$  (d)  $\text{O}_2, \text{H}_2$

**Answer.** (d)

44. The cathodic reaction in electrolysis of dilute sulphuric acid with platinum electrode is

- (a) neutralization (b) oxidation  
(c) reduction (d) oxidation & reduction

**Answer.** (a)

45. If the specific conductance and conductance of a solution are same, then the cell constant is equal to

- (a) 0 (b) 0.5  
(c) 1.0 (d) 10.0

**Answer.** (c)

46. On passing one faraday of electricity, one mole of metal is deposited from the solution of

- (a)  $\text{KCl}$  (b)  $\text{BaCl}_2$   
(c)  $\text{AlCl}_3$  (d) none of these

**Answer.** (a)

47. A certain current liberated 1.008 g of hydrogen in 2 hours. How many grams of copper can be deposited by the same current flowing for the same time in  $\text{CuSO}_4$  solution. (at mass of  $\text{Cu} = 63.5$ )

- (a) 31.75 g (b) 63.5 g  
(c) 127 g (d) 15.875 g

**Answer.** (a)

48. The specific conductance of a 0.01 M solution of  $\text{KCl}$  is  $1.4 \times 10^{-3} \text{ ohm}^{-1} \text{ cm}^{-1}$  at 298 K. Its equivalent conductance is

- (a) 0.14 (b) 1.4  
(c) 14.0 (d) 140

**Answer.** (d)

49. The distance between two electrodes of a cell is 3.0 cm and area of each electrode is 6.0 cm. The cell constant is

- (a) 2.0 (b) 1.0  
(c) 0.5 (d) 18

**Answer.** (c)

50. The specific conductance of  $\text{NaCl}$  solution at  $18^\circ\text{C}$  is  $0.0124 \text{ ohm}^{-1} \text{ cm}^2 \text{ eqvt}^{-1}$  and the resistance of the cell containing the solution at the same temperature is 50.0 ohm. The cell constant will be

- (a) 0.62 (b) 0.31  
(c) 0.124 (d) 0.000248

**Answer.** (a)