



Conjugated Unsaturated Systems

W

hat do the colors of a plant, a carrot, your favorite pair of blue jeans, and our ability to see all have in common? They all result from molecules that have a sequence of alternating double and single bonds. This bonding pattern leads to a phenomenon known as conjugation. Conjugated compounds include β -carotene, which produces the orange color of carrots, chlorophyll a, which is the green pigment that carries on photosynthesis, and indigo, the pigment that gives your blue jeans their distinctive color. It is the conjugation of their double bonds and the way these compounds interact with light (both visible and ultraviolet) that produces their colors. Moreover, such molecules also have unique aspects of reactivity because the anions, cations, and radical species formed from them possess greater than normal stabilization. As a result, they can participate in a large and unique spectrum of organic chemistry.

IN THIS CHAPTER WE WILL CONSIDER:

- conjugation and resonance structures based on radicals, cations, and anions
- the unique physical properties of conjugated systems, especially as observed by UV-Vis spectroscopy
- a special transformation, named the Diels-Alder reaction, that can combine conjugated molecules known as 1,3-dienes with certain partners to create six-membered rings containing up to four new chirality centers

[WHY DO THESE TOPICS MATTER?] At the end of the chapter, we will see just how Otto Diels and Kurt Alder first discovered the reaction that would later bear their names and garner them the Nobel Prize, noting that it was nearly discovered by a number of other people who had done the same chemistry, but could not figure out what they had made!

13.1 INTRODUCTION

At its essence, a **conjugated system** involves at least one atom with a p orbital adjacent to at least one π bond. The adjacent atom with the p orbital can be part of another π bond, as in 1,3-butadiene, or a radical, cationic, or anionic reaction intermediate. If an example derives specifically from a propenyl group, the common name for this group is **allyl**. In general when we are considering a radical, cation, or anion that is adjacent to one or more π bonds in a molecule other than propene, the adjacent position is called **allylic**. Below we show the formula for butadiene, resonance hybrids for the allyl radical and an **allylic carbocation**, and molecular orbital representations for each one.

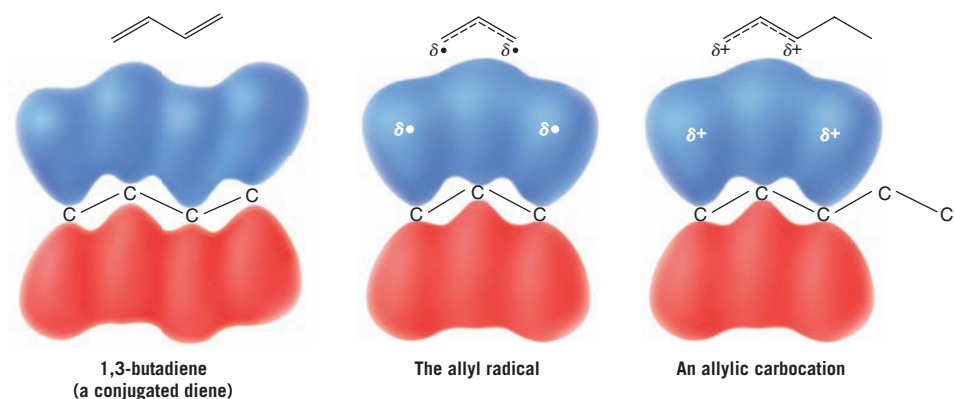

Radical substitution at an allylic position, as we saw in Chapter 10, is especially favorable precisely because the intermediate radical is part of a conjugated system.

SOLVED PROBLEM 13.1

Identify all of the positions bearing allylic hydrogen atoms in cryptoxanthin (a natural pigment).

STRATEGY AND ANSWER: Allylic hydrogen atoms in cryptoxanthin are found on the sp^3 -hybridized carbons adjacent to π bonds. These positions are labeled by boxes in the formula below.

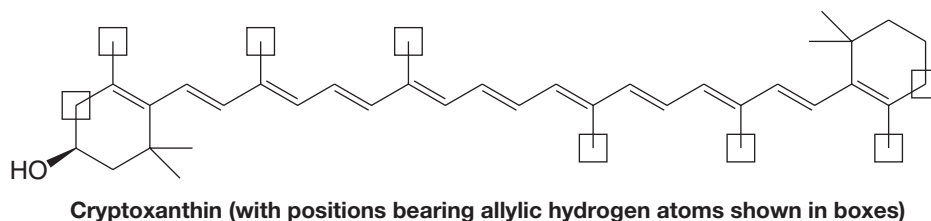

13.2 THE STABILITY OF THE ALLYL RADICAL

An explanation of the stability of the allyl radical can be approached in two ways: in terms of molecular orbital theory and in terms of resonance theory (Section 1.8). As we shall see soon, both approaches give us equivalent descriptions of the allyl radical. The molecular orbital approach is easier to visualize, so we shall begin with it. (As preparation for this section, it may help the reader to review the molecular orbital theory given in Sections 1.11 and 1.13.)

13.2A Molecular Orbital Description of the Allyl Radical

As an allylic hydrogen atom is abstracted from propene (see the following diagram), the sp^3 -hybridized carbon atom of the methyl group changes its hybridization state to sp^2 (see



Section 10.6). The p orbital of this new sp^2 -hybridized carbon atom overlaps with the p orbital of the central carbon atom.

- In the allyl radical three p orbitals overlap to form a set of π molecular orbitals that encompass all three carbon atoms.
- The new p orbital of the allyl radical is said to be *conjugated* with those of the double bond, and the allyl radical is said to be a *conjugated unsaturated system*.

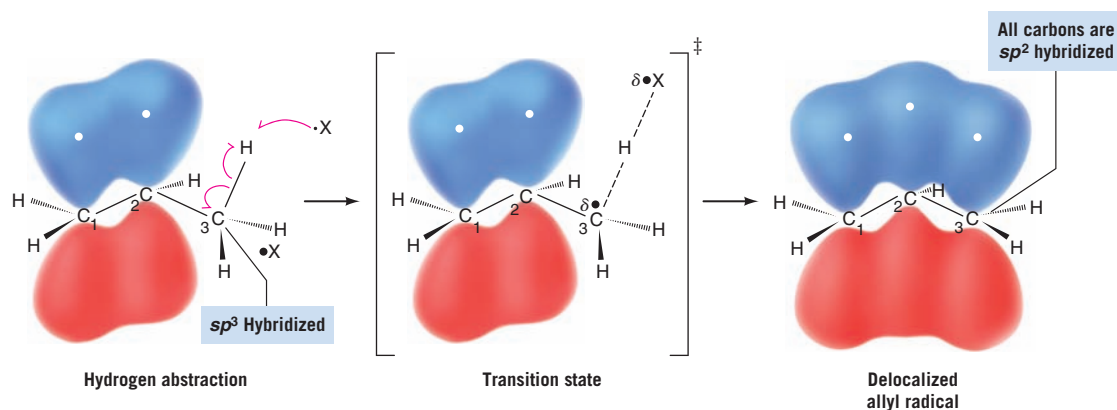

- The unpaired electron of the allyl radical and the two electrons of the π bond are **delocalized** over all three carbon atoms.

Delocalization of the unpaired electron accounts for the greater stability of the allyl radical when compared to primary, secondary, and tertiary radicals. Although some delocalization occurs in primary, secondary, and tertiary radicals, delocalization is not as effective because it occurs only through hyperconjugation (Section 6.11B) with σ bonds.

The diagram in Fig. 13.1 illustrates how the three p orbitals of the allyl radical combine to form three π molecular orbitals. (*Remember:* The number of molecular orbitals that results always equals the number of atomic orbitals that combine; see Section 1.11.) The bonding π molecular orbital is of lowest energy; it encompasses all three carbon atoms and is occupied by two spin-paired electrons. This bonding π orbital is the result of having p orbitals with lobes of the same sign overlap between adjacent carbon atoms. This type of overlap, as we recall, increases the π -electron density in the regions between the atoms where it is needed for bonding. The nonbonding π orbital is occupied by one unpaired electron, and it has a node at the central carbon atom. This node means that the unpaired electron is located in the vicinity of carbon atoms 1 and 3 only. The antibonding π molecular orbital results when orbital lobes of opposite sign overlap between adjacent carbon atoms. Such overlap means that in the antibonding π orbital there is a node between each pair of carbon atoms. This antibonding orbital of the allyl radical is of highest energy and is empty in the ground state of the radical.

We can illustrate the picture of the allyl radical given by molecular orbital theory with the following structure:

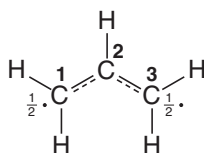

We indicate with dashed lines that both carbon-carbon bonds are partial double bonds. This accommodates one of the things that molecular orbital theory tells us: *that there is a π bond encompassing all three atoms*. We also place the symbol $\frac{1}{2}$ beside the C1 and C3 atoms. This presentation denotes a second thing molecular orbital theory tells us: *that electron density from the unpaired electron is equal in the vicinity of C1 and C3*. Finally, implicit in the molecular orbital picture of the allyl radical is this: the two ends of the allyl radical are *equivalent*. This aspect of the molecular orbital description is also implicit in the formula just given.

FIGURE 13.1 Combination of three atomic p orbitals to form three π molecular orbitals in the allyl radical. The bonding π molecular orbital is formed by the combination of the three p orbitals with lobes of the same sign overlapping above and below the plane of the atoms. The nonbonding π molecular orbital has a node at C2. The antibonding π molecular orbital has two nodes: between C1 and C2 and between C2 and C3. The shapes of molecular orbitals for the allyl radical calculated using quantum mechanical principles are shown alongside the schematic orbitals.

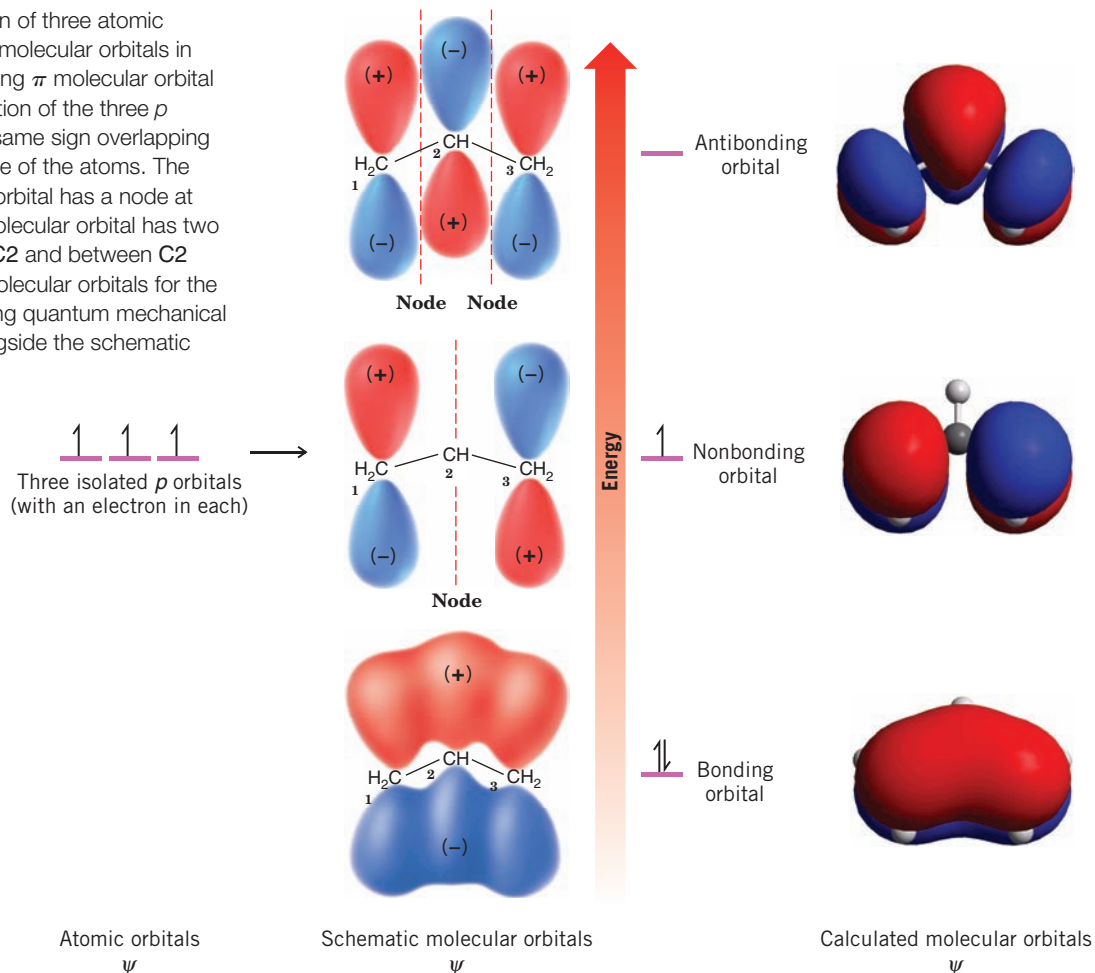

13.2B Resonance Description of the Allyl Radical

One structure that we can write for the allyl radical is **A**:



However, we might just as well have written the equivalent structure, **B**:



In writing structure **B**, we do not mean to imply that we have simply taken structure **A** and turned it over. We have not moved the nuclei. What we have done is move the electrons in the following way:



Resonance theory (Section 1.8) tells us that whenever we can write two structures for a chemical entity *that differ only in the positions of the electrons*, the entity cannot be represented by either structure alone but is a *hybrid* of both. We can represent the hybrid in two ways. We can write both structures **A** and **B** and connect them with a double-headed arrow, the special arrow we use to indicate that they are resonance structures:



Or we can write a single structure, **C**, that blends the features of both resonance structures:

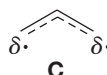



We see, then, that resonance theory gives us exactly the same picture of the allyl radical that we obtained from molecular orbital theory. Structure **C** describes the carbon-carbon bonds of the allyl radical as partial double bonds. The resonance structures **A** and **B** also tell us that the unpaired electron is associated only with the C1 and C3 atoms. We indicate this in structure **C** by placing a δ beside C1 and C3. Because resonance structures **A** and **B** are equivalent, the electron density from the unpaired electron is shared equally by C1 and C3.

Another rule in resonance theory is the following:

- Whenever equivalent **resonance structures** can be written for a chemical species, the chemical species is much more stable than any single resonance structure would indicate.

If we were to examine either **A** or **B** alone, we might decide incorrectly that it resembled a primary radical. Thus, we might estimate the stability of the allyl radical as approximately that of a primary radical. In doing so, we would greatly underestimate the stability of the allyl radical. Resonance theory tells us, however, that since **A** and **B** are *equivalent resonance structures*, the allyl radical should be much more stable than either, that is, much more stable than a primary radical. This correlates with what experiments have shown to be true: **the allyl radical is even more stable than a tertiary radical.**

We should point out that a structure that would indicate an unpaired electron on the central carbon of the allyl system, as shown here, is not a proper resonance structure because resonance theory dictates that all resonance structures must have the same number of unpaired electrons (Section 13.4A). This structure shows three unpaired electrons, whereas the other resonance structures for the allyl radical have only one unpaired electron.

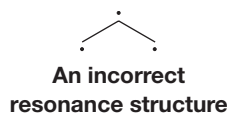

SOLVED PROBLEM 13.2

Subjecting propene labeled with ^{13}C at carbon 1 to allylic chlorination (see below) leads to a 50:50 mixture of 1-chloropropene labeled at C1 and at C3. Write a mechanism that explains this result. (An asterisk * next to a carbon atom indicates that the carbon atom is ^{13}C .)

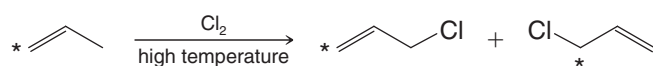

STRATEGY AND ANSWER: We recall (Section 10.8A) that the mechanism for allylic chlorination involves the formation of a resonance-stabilized radical created by having a chlorine atom abstract an allylic hydrogen atom. Because the radical formed in this case is a hybrid of two structures (which are equivalent except for the position of the label), it can react with Cl_2 at either end to give a 50 : 50 mixture of the differently labeled products.

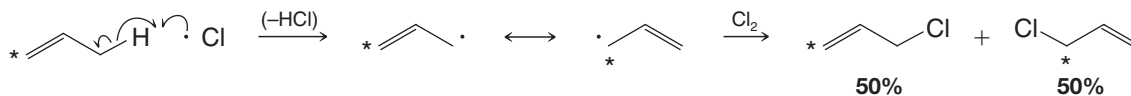

Consider the allylic bromination of cyclohexene labeled at C3 with ^{13}C . Neglecting stereoisomers, what products would you expect from this reaction?

PRACTICE PROBLEM 13.1

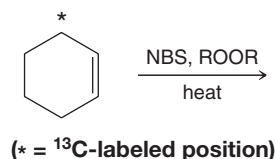

13.3 THE ALLYL CATION

Carbocations can be allylic as well.

- The **allyl (propenyl) cation** ($\text{CH}_2=\text{CH}-\text{CH}_2^+$) is even more stable than a secondary carbocation and is almost as stable as a tertiary carbocation.

In general terms, the relative order of stabilities of carbocations is that given here.

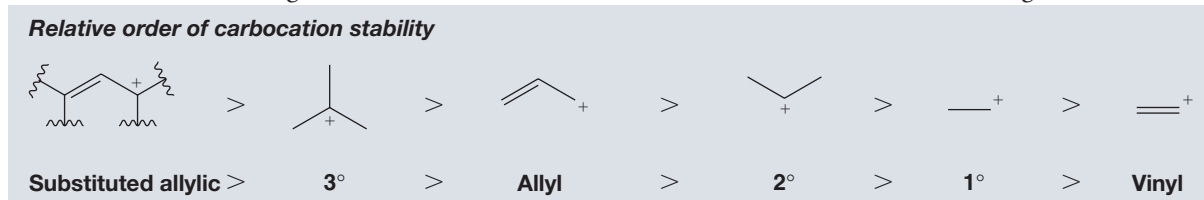

The molecular orbital description of the allyl cation is shown in Fig. 13.2.

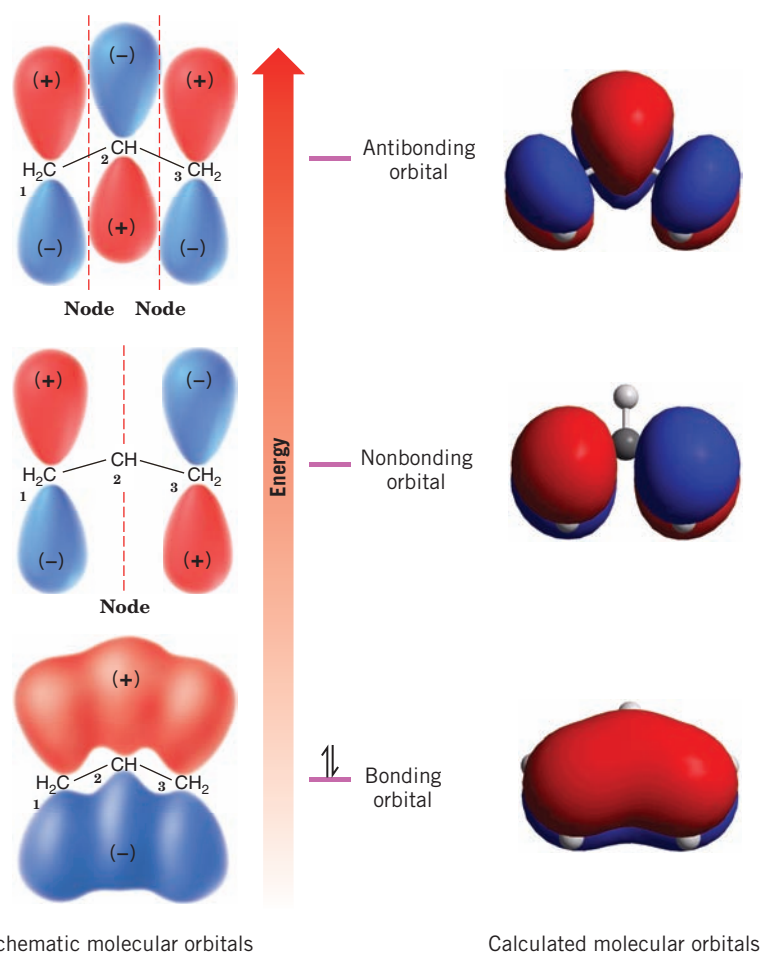
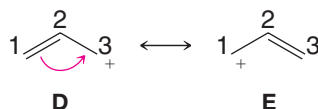

FIGURE 13.2 The π molecular orbitals of the allyl cation. The allyl cation, like the allyl radical (Fig. 13.1), is a conjugated unsaturated system. The shapes of molecular orbitals for the allyl cation calculated using quantum mechanical principles are shown alongside the schematic orbitals.

The bonding π molecular orbital of the allyl cation, like that of the **allyl radical** (Fig. 13.1), contains two spin-paired electrons. The nonbonding π molecular orbital of the allyl cation, however, is empty.

Resonance theory depicts the allyl cation as a hybrid of structures **D** and **E** represented here:



Because **D** and **E** are *equivalent* resonance structures, resonance theory predicts that the allyl cation should be unusually stable. Since the positive charge is located on **C3** in **D** and on **C1** in **E**, resonance theory also tells us that the positive charge should be delocalized over both carbon atoms. Carbon atom 2 carries none of the positive charge. The hybrid structure **F** includes charge and bond features of both **D** and **E**:

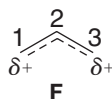

SOLVED PROBLEM 13.3

Allyl bromide (3-bromo-1-propene) forms a carbocation readily. For example, it undergoes S_N1 reactions. Explain this observation.

STRATEGY AND ANSWER: Ionization of allyl bromide (at right) produces an allyl cation that is unusually stable (far more stable than a simple primary carbocation) because it is resonance stabilized.



- (a) Draw resonance structures for the carbocation that could be formed from (*E*)-2-butenyl trifluoromethanesulfonate.

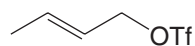

- (b) One of the resonance structures for this carbocation should be a more important contributor to the resonance hybrid than the other. Which resonance structure would be the greater contributor?
- (c) What products would you expect if this carbocation reacted with a chloride ion?

PRACTICE PROBLEM 13.2

13.4 RESONANCE THEORY REVISITED

We have already used **resonance** theory in earlier chapters, and we have been using it extensively in this chapter because we are describing radicals and ions with delocalized electrons (and charges) in π bonds. Resonance theory is especially useful with systems like this, and we shall use it again and again in the chapters that follow. In Section 1.8 we had an introduction to resonance theory and an initial presentation of some rules for writing resonance structures. It should now be helpful, in light of our previous discussions of relative carbocation stability and radicals, and our growing understanding of conjugated systems, to review and expand on those rules as well as those for the ways in which we estimate the relative contribution a given structure will make to the overall hybrid.

Helpful Hint

Resonance is an important tool we use frequently when discussing structure and reactivity.

13.4A HOW TO Write Proper Resonance Structures

- 1. Resonance structures exist only on paper.** Although they have no real existence of their own, **resonance structures** are useful because they allow us to describe molecules, radicals, and ions for which a single Lewis structure is inadequate. Instead, we write two or more Lewis structures, calling them resonance structures or resonance contributors. We connect these structures by double-headed arrows (\longleftrightarrow), and we say that the hybrid of all of them represents the real molecule, radical, or ion.
- 2. In writing resonance structures, we are only allowed to move electrons.** The positions of the nuclei of the atoms must remain the same in all of the structures. Structure **3**

is not a resonance structure for the allylic cation, for example, because in order to form it we would have to move a hydrogen atom and this is not permitted:

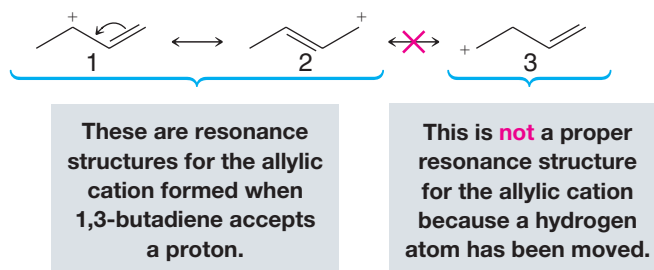

Generally speaking, when we move electrons we move only those of π bonds (as in the example above) and those of lone pairs.

3. **All of the structures must be proper Lewis structures.** We should not write structures in which carbon has five bonds, for example:

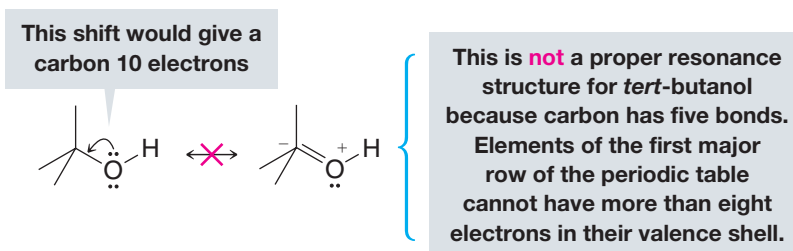

4. **All resonance structures must have the same number of unpaired electrons.** The structure on the right is not a proper resonance structure for the allyl radical because it contains three unpaired electrons whereas the allyl radical contains only one:

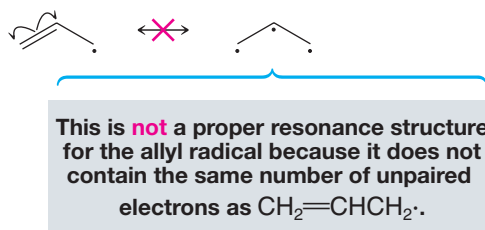

5. **All atoms that are part of the delocalized π -electron system must lie in a plane or be nearly planar.** For example, 2,3-di-*tert*-butyl-1,3-butadiene behaves like a *non-conjugated* diene because the large *tert*-butyl groups twist the structure and prevent the double bonds from lying in the same plane. Because they are not in the same plane, the *p* orbitals at C2 and C3 do not overlap and delocalization (and therefore resonance) is prevented:



2,3-Di-*tert*-butyl-1,3-butadiene

6. **The energy of the actual molecule is lower than the energy that might be estimated for any contributing structure.** The actual allyl cation, for example, is more stable than either resonance structure **4** or **5** taken separately would indicate. Structures **4** and **5** resemble primary carbocations and yet the allyl cation is more stable (has lower energy) than a secondary carbocation. Chemists often call this kind of stabilization *resonance stabilization*:

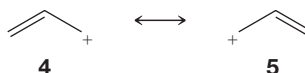



In Chapter 14 we shall find that benzene is highly resonance stabilized because it is a hybrid of the two equivalent forms that follow:

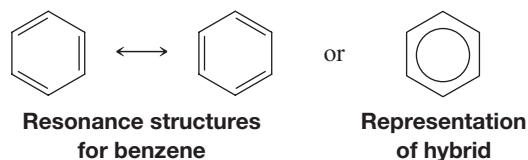

- 7. Equivalent resonance structures make equal contributions to the hybrid, and a system described by them has a large resonance stabilization.** Structures **4** and **5** above make equal contributions to the allylic cation because they are equivalent. They also make a large stabilizing contribution and account for allylic cations being unusually stable. The same can be said about the contributions made by the equivalent structures **A** and **B** (Section 13.2B) for the allyl radical.
- 8. The more stable a structure is (when taken by itself), the greater is its contribution to the hybrid.** Structures that are not equivalent do not make equal contributions. For example, the following cation is a hybrid of structures **6** and **7**. Structure **6** makes a greater contribution than **7** because structure **6** is a more stable tertiary carbocation while structure **7** is a primary cation:

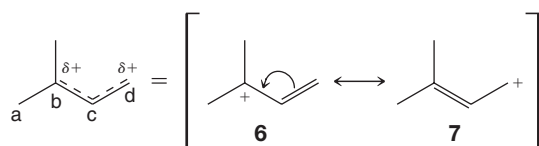

That **6** makes a larger contribution means that the partial positive charge on carbon **b** of the hybrid will be larger than the partial positive charge on carbon **d**. It also means that the bond between carbon atoms **c** and **d** will be more like a double bond than the bond between carbon atoms **b** and **c**.

13.4B HOW TO Estimate the Relative Stability of Contributing Resonance Structures

The following rules will help us in making decisions about the relative stabilities of resonance structures.

- a. The more covalent bonds a structure has, the more stable it is.** This is exactly what we would expect because we know that forming a covalent bond lowers the energy of atoms. This means that of the following structures for 1,3-butadiene, **8** is by far the most stable and makes by far the largest contribution because it contains one more bond. (It is also more stable for the reason given under rule **c**.)

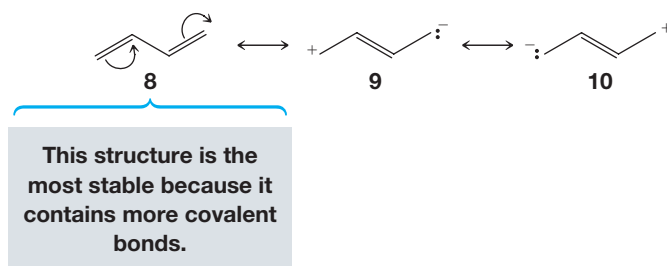

- b. Structures in which all of the atoms have a complete valence shell of electrons (i.e., the noble gas structure) are especially stable and make large contributions to the hybrid.** Again, this is what we would expect from what we know about bonding. This means, for example, that **12** makes a larger stabilizing contribution to

the cation below than **11** because all of the atoms of **12** have a complete valence shell. (Notice too that **12** has more covalent bonds than **11**; see rule a.)

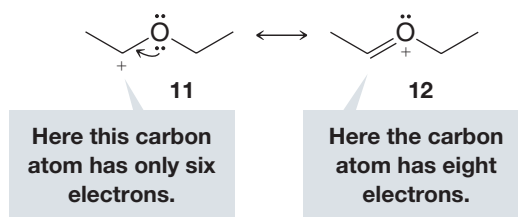

- c. Charge separation decreases stability.** Separating opposite charges requires energy. Therefore, structures in which opposite charges are separated have greater energy (lower stability) than those that have no charge separation. This means that of the following two structures for vinyl chloride, structure **13** makes a larger contribution because it does not have separated charges. (This does not mean that structure **14** does not contribute to the hybrid; it just means that the contribution made by **14** is smaller.)



SOLVED PROBLEM 13.4

Write resonance structures for and tell which structure would be the greater contributor to the resonance hybrid.

STRATEGY AND ANSWER: We write the structure for the molecule and then move the electron pairs as shown below. Then we examine the two structures. The second structure contains separated charges (which would make it less stable) and the first structure contains more bonds (which would make it more stable). Both factors tell us that the first structure is more stable. Consequently, it should be the greater contributor to the hybrid.



PRACTICE PROBLEM 13.3 Write the important resonance structures for each of the following:

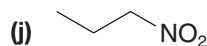
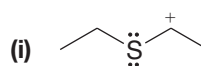
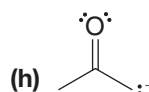
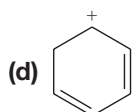
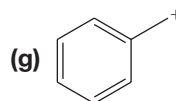
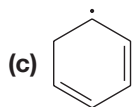
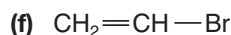
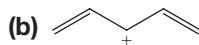
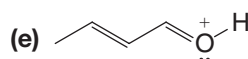
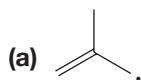



From each set of resonance structures that follow, designate the one that would contribute most to the hybrid and explain your choice:

PRACTICE PROBLEM 13.4

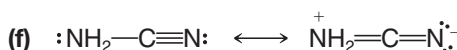
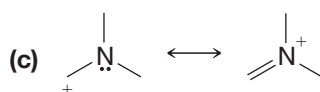
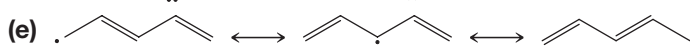
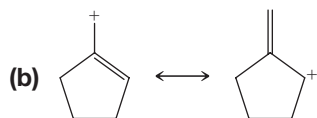
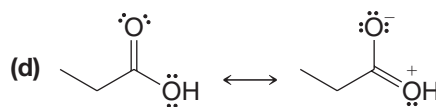
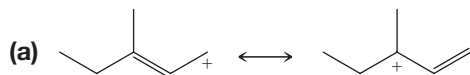

The following enol (an *alkene-alcohol*) and keto (a *ketone*) forms of C_2H_4O differ in the positions for their electrons, but they are not resonance structures. Explain why they are not.

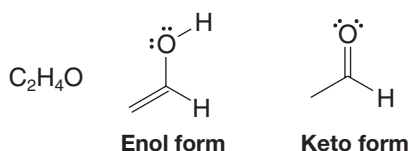

PRACTICE PROBLEM 13.5

13.5 ALKADIENES AND POLYUNSATURATED HYDROCARBONS

Many hydrocarbons are known that contain more than one double or triple bond. A hydrocarbon that contains two double bonds is called an **alkadiene**; one that contains three double bonds is called an **alkatriene**, and so on. Colloquially, these compounds are often referred to simply as dienes or trienes. A hydrocarbon with two triple bonds is called an **alkadiyne**, and a hydrocarbon with a double and triple bond is called an **alkenyne**.

The following examples of polyunsaturated hydrocarbons illustrate how specific compounds are named. Recall from IUPAC rules (Sections 4.5 and 4.6) that the numerical locants for double and triple bonds can be placed at the beginning of the name or immediately preceding the respective suffix. We provide examples of both styles.

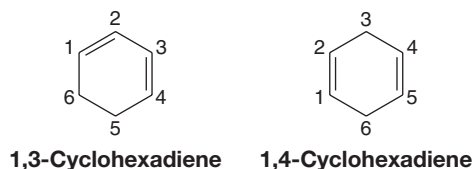
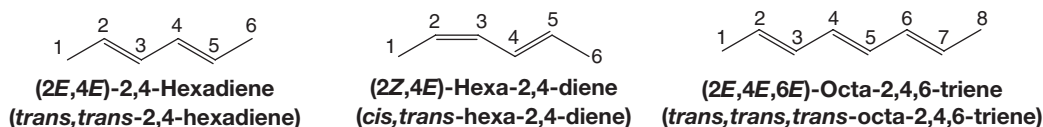
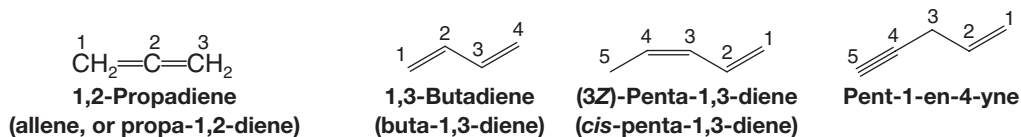

The multiple bonds of polyunsaturated compounds are classified as being **cumulated**, **conjugated**, or **isolated**.

- The double bonds of a 1,2-diene (such as 1,2-propadiene, also called allene) are said to be **cumulated** because one carbon (the central carbon) participates in two double bonds.

Hydrocarbons whose molecules have cumulated double bonds are called **cumulenes**. The name **allene** (Section 5.18) is also used as a class name for molecules with two cumulated double bonds:

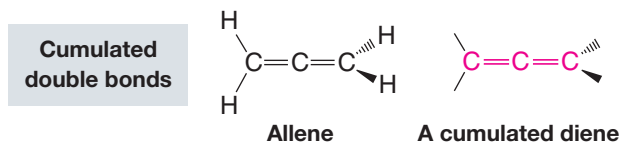

An example of a conjugated diene is 1,3-butadiene.

- In **conjugated** polyenes the double and single bonds *alternate* along the chain:

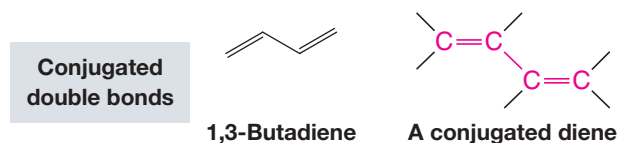

(2*E*,4*E*,6*E*)-Octa-2,4,6-triene is an example of a conjugated alkatriene.

- If one or more saturated carbon atoms intervene between the double bonds of an alkadiene, the double bonds are said to be **isolated**.

An example of an isolated diene is 1,4-pentadiene:

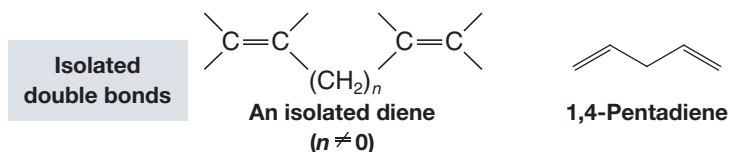

- PRACTICE PROBLEM 13.6**
- Which other compounds in Section 13.5 are conjugated dienes?
 - Which other compounds are isolated dienes?
 - Which compound is an isolated enyne?

In Chapter 5 we saw that appropriately substituted cumulated dienes (allenes) give rise to chiral molecules. Cumulated dienes have had some commercial importance, and cumulated double bonds are occasionally found in naturally occurring molecules. In general, cumulated dienes are less stable than isolated dienes.

The double bonds of isolated dienes behave just as their name suggests—as isolated “enes.” They undergo all of the reactions of alkenes, and, except for the fact that they are capable of reacting twice, their behavior is not unusual. Conjugated dienes are far more interesting because we find that their double bonds interact with each other. This interaction leads to unexpected properties and reactions. We shall therefore consider the chemistry of conjugated dienes in detail.

13.6 1,3-BUTADIENE: ELECTRON DELOCALIZATION

13.6A Bond Lengths of 1,3-Butadiene

The carbon–carbon bond lengths of 1,3-butadiene have been determined and are shown here:

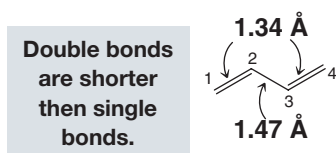



The C1—C2 bond and the C3—C4 bond are (within experimental error) the same length as the carbon–carbon double bond of ethene. The central bond of 1,3-butadiene (1.47 Å), however, is considerably shorter than the single bond of ethane (1.54 Å).

This should not be surprising. All of the carbon atoms of 1,3-butadiene are sp^2 hybridized and, as a result, the central bond of butadiene results from overlapping sp^2 orbitals. And, as we know, a sigma bond that is sp^3-sp^3 is *longer*. There is, in fact, a steady decrease in bond length of carbon–carbon single bonds as the hybridization state of the bonded atoms changes from sp^3 to sp (Table 13.1).

TABLE 13.1 CARBON–CARBON SINGLE-BOND LENGTHS AND HYBRIDIZATION STATE

Compound	Hybridization State	Bond Length (Å)
H ₃ C—CH ₃	sp^3-sp^3	1.54
CH ₂ =CH—CH ₃	sp^2-sp^3	1.50
CH ₂ =CH—CH=CH ₂	sp^2-sp^2	1.47
HC≡C—CH ₃	$sp-sp^3$	1.46
HC≡C—CH=CH ₂	$sp-sp^2$	1.43
HC≡C—C≡CH	$sp-sp$	1.37

13.6B Conformations of 1,3-Butadiene

There are two possible planar conformations of 1,3-butadiene: the *s-cis* and the *s-trans* conformations.

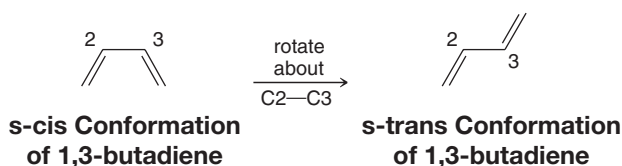

These are not true cis and trans forms since the *s-cis* and *s-trans* conformations of 1,3-butadiene can be interconverted through rotation about the single bond (hence the prefix *s*). The *s-trans* conformation is the predominant one at room temperature. We shall see that the *s-cis* conformation of 1,3-butadiene and other 1,3-conjugated alkenes is necessary for the Diels–Alder reaction (Section 13.10).

SOLVED PROBLEM 13.5

Provide an explanation for the fact that many more molecules are in the *s-trans* conformation of 1,3-butadiene at equilibrium.

STRATEGY AND ANSWER: The *s-cis* conformation of 1,3-butadiene is less stable, and therefore less populated, than the *s-trans* conformer because it has steric interference between the hydrogen atoms at carbons 1 and 4. Interference of this kind does not exist in the *s-trans* conformation, and therefore, the *s-trans* conformation is more stable and more populated at equilibrium.

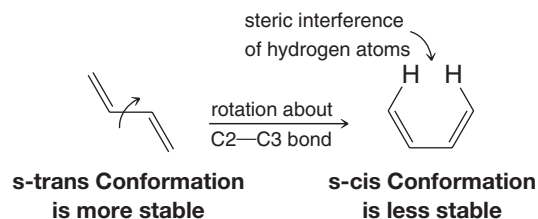

13.6C Molecular Orbitals of 1,3-Butadiene

The central carbon atoms of 1,3-butadiene (Fig. 13.3) are close enough for overlap to occur between the p orbitals of C2 and C3. This overlap is not as great as that between the orbitals of C1 and C2 (or those of C3 and C4). The C2–C3 orbital overlap, however,

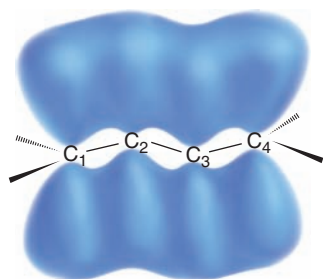

FIGURE 13.3 The p orbitals of 1,3-butadiene. (See Fig. 13.4 for the shapes of calculated molecular orbitals for 1,3-butadiene.)

gives the central bond partial double-bond character and allows the four π electrons of 1,3-butadiene to be delocalized over all four atoms.

Figure 13.4 shows how the four p orbitals of 1,3-butadiene combine to form a set of four π molecular orbitals.

- Two of the π molecular orbitals of 1,3-butadiene are bonding molecular orbitals. In the ground state these orbitals hold the four π electrons with two spin-paired electrons in each.
- The other two π molecular orbitals are antibonding molecular orbitals. In the ground state these orbitals are unoccupied.

An electron can be excited from the highest occupied molecular orbital (HOMO) to the lowest unoccupied molecular orbital (LUMO) when 1,3-butadiene absorbs light with a wavelength of 217 nm. (We shall study the absorption of light by unsaturated molecules in Section 13.8.)

- The delocalized bonding that we have just described for 1,3-butadiene is characteristic of all conjugated polyenes.

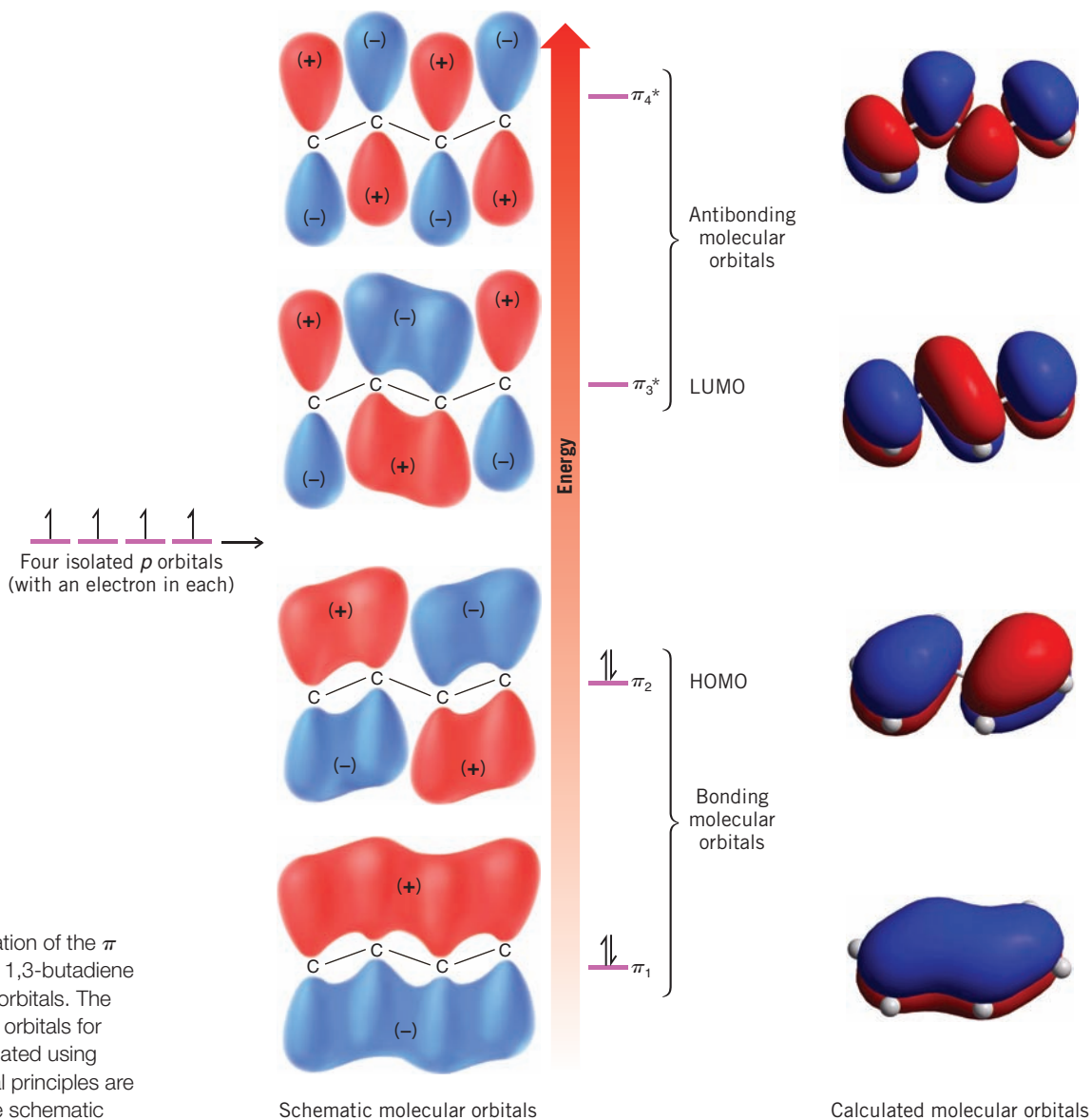

FIGURE 13.4 Formation of the π molecular orbitals of 1,3-butadiene from four isolated p orbitals. The shapes of molecular orbitals for 1,3-butadiene calculated using quantum mechanical principles are shown alongside the schematic orbitals.



13.7 THE STABILITY OF CONJUGATED DIENES

- Conjugated alkadienes are thermodynamically more stable than isomeric isolated alkadienes.

Two examples of this extra stability of conjugated dienes can be seen in an analysis of the heats of hydrogenation given in Table 13.2.

TABLE 13.2 HEATS OF HYDROGENATION OF ALKENES AND ALKADIENES

Compound	H ₂ (mol)	ΔH° (kJ mol ⁻¹)
1-Butene	1	-127
1-Pentene	1	-126
<i>trans</i> -2-Pentene	1	-115
1,3-Butadiene	2	-239
<i>trans</i> -1,3-Pentadiene	2	-226
1,4-Pentadiene	2	-254
1,5-Hexadiene	2	-253

In itself, 1,3-butadiene cannot be compared directly with an isolated diene of the same chain length. However, a comparison can be made between the heat of hydrogenation of 1,3-butadiene and that obtained when two molar equivalents of 1-butene are hydrogenated:

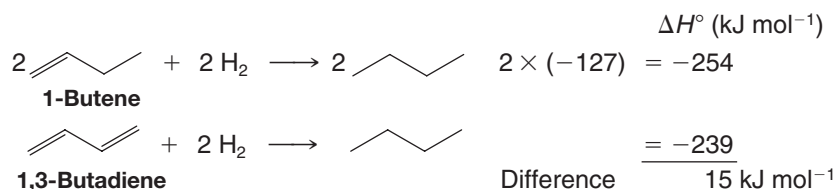

Because 1-butene has a monosubstituted double bond like those in 1,3-butadiene, we might expect hydrogenation of 1,3-butadiene to liberate the same amount of heat (254 kJ mol⁻¹) as two molar equivalents of 1-butene. We find, however, that 1,3-butadiene liberates only 239 kJ mol⁻¹, 15 kJ mol⁻¹ less than expected. We conclude, therefore, that conjugation imparts some extra stability to the conjugated system (Fig. 13.5).

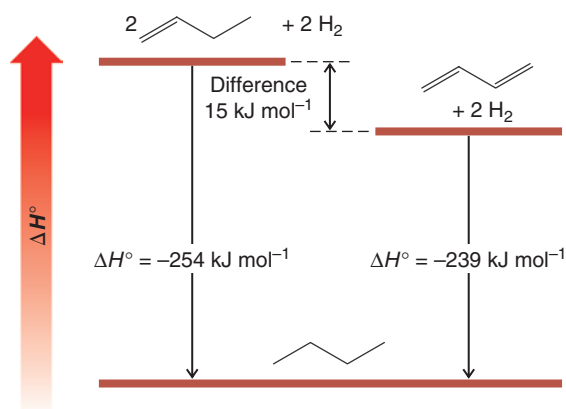
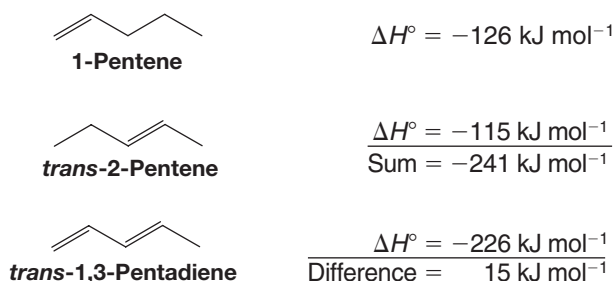

FIGURE 13.5 Heats of hydrogenation of 2 mol of 1-butene and 1 mol of 1,3-butadiene.

An assessment of the stabilization that conjugation provides *trans*-1,3-pentadiene can be made by comparing the heat of hydrogenation of *trans*-1,3-pentadiene to the sum of

the heats of hydrogenation of 1-pentene and *trans*-2-pentene. This way we are comparing double bonds of comparable types:



We see from these calculations that conjugation affords *trans*-1,3-pentadiene an extra stability of 15 kJ mol^{-1} , a value that is equivalent, to two significant figures, to the one we obtained for 1,3-butadiene (15 kJ mol^{-1}).

When calculations like these are carried out for other conjugated dienes, similar results are obtained; *conjugated dienes are found to be more stable than isolated dienes*. The question, then, is this: what is the source of the extra stability associated with conjugated dienes? There are two factors that contribute. The extra stability of conjugated dienes arises in part from the stronger central bond that they contain and, in part, from the additional delocalization of the π electrons that occurs in conjugated dienes.

SOLVED PROBLEM 13.6

Which diene would you expect to be more stable: 1,3-cyclohexadiene or 1,4-cyclohexadiene? Why? What experiment could you carry out to confirm your answer?

STRATEGY AND ANSWER: 1,3-Cyclohexadiene is conjugated, and on that basis we would expect it to be more stable. We could determine the heats of hydrogenation of the two compounds, and since on hydrogenation each compound yields the same product, the diene with the smaller heat of hydrogenation would be the more stable one.

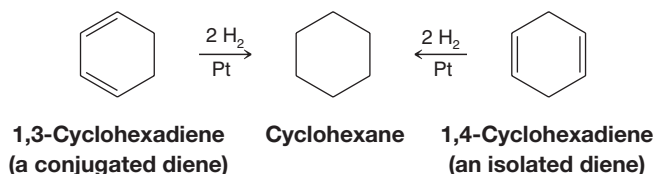

13.8 ULTRAVIOLET-VISIBLE SPECTROSCOPY

The extra stability of conjugated dienes when compared to corresponding unconjugated dienes can also be seen in data from **ultraviolet-visible (UV-Vis) spectroscopy**. When electromagnetic radiation in the UV and visible regions passes through a compound containing multiple bonds, a portion of the radiation is usually absorbed by the compound. Just how much radiation is absorbed depends on the wavelength of the radiation and the structure of the compound.

- The absorption of UV-Vis radiation is caused by transfer of energy from the radiation beam to electrons that can be excited to higher energy orbitals.

In Section 13.8C we shall return to discuss specifically how data from UV-Vis spectroscopy demonstrate the additional stability of conjugated dienes. First, in Section 13.8A we briefly review the properties of electromagnetic radiation, and then in Section 13.8B we look at how data from a UV-Vis spectrophotometer are obtained.



13.8A The Electromagnetic Spectrum

According to quantum mechanics, electromagnetic radiation has a dual and seemingly contradictory nature.

- Electromagnetic radiation can be described as a wave occurring simultaneously in electrical and magnetic fields. It can also be described as if it consisted of particles called quanta or photons.

Different experiments disclose these two different aspects of electromagnetic radiation. They are not seen together in the same experiment.

- A wave is usually described in terms of its **wavelength** (λ) or its **frequency** (ν).

A simple wave is shown in Fig. 13.6. The distance between consecutive crests (or troughs) is the wavelength. The number of full cycles of the wave that pass a given point each second, as the wave moves through space, is called the *frequency* and is measured in cycles per second (cps), or **hertz (Hz)**.*

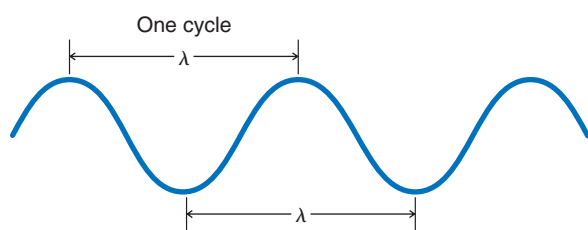

FIGURE 13.6 A simple wave and its wavelength, λ .

All electromagnetic radiation travels through a vacuum at the same velocity. This velocity (c), called the velocity of light, is $2.99792458 \times 10^8 \text{ m s}^{-1}$ and relates to wavelength and frequency as $c = \lambda\nu$. The wavelengths of electromagnetic radiation are expressed either in meters (m), millimeters ($1 \text{ mm} = 10^{-3} \text{ m}$), micrometers ($1 \mu\text{m} = 10^{-6} \text{ m}$), or nanometers ($1 \text{ nm} = 10^{-9} \text{ m}$). [An older term for micrometer is *micron* (abbreviated μ) and an older term for nanometer is *millimicron*.]

The energy of a quantum of electromagnetic energy is directly related to its frequency:

$$E = h\nu$$

where h = Planck's constant, $6.63 \times 10^{-34} \text{ J s}$

ν = frequency (Hz)

The higher the frequency (ν) of radiation, the greater is its energy.

X-rays, for example, are much more energetic than rays of visible light. The frequencies of X-rays are on the order of 10^{19} Hz , while those of visible light are on the order of 10^{15} Hz .

Since $\nu = c/\lambda$, the energy of electromagnetic radiation is inversely proportional to its wavelength:

$$E = \frac{hc}{\lambda}$$

where c = velocity of light

The shorter the wavelength (λ) of radiation, the greater is its energy.

X-rays have wavelengths on the order of 0.1 nm and are very energetic, whereas visible light has wavelengths between 400 and 750 nm and is, therefore, of lower energy than X-rays.†

*The term hertz (after the German physicist H. R. Hertz), abbreviated Hz, is used in place of the older term *cycles per second* (cps). Frequency of electromagnetic radiation is also sometimes expressed in *wavenumbers*—that is, the number of waves per centimeter.

†A convenient formula that relates wavelength (in nm) to the energy of electromagnetic radiation is the following:

$$E \text{ (in kJ mol}^{-1}\text{)} = \frac{1.20 \times 10^{-9} \text{ kJ mol}^{-1}}{\text{wavelength in nanometers}}$$

It may be helpful to point out, too, that for visible light, wavelengths (and thus frequencies) are related to what we perceive as colors. The light that we call red light has a wavelength of approximately 650 nm. The light we call violet light has a wavelength of approximately 400 nm. All of the other colors of the visible spectrum (the rainbow) lie in between these wavelengths.

The different regions of the **electromagnetic spectrum** are shown in Fig. 13.7. Nearly every portion of the electromagnetic spectrum from the region of X-rays to that of microwaves and radio waves has been used in elucidating structures of atoms and molecules. Although techniques differ according to the portion of the electromagnetic spectrum in which we are working, there is a consistency and unity of basic principles.

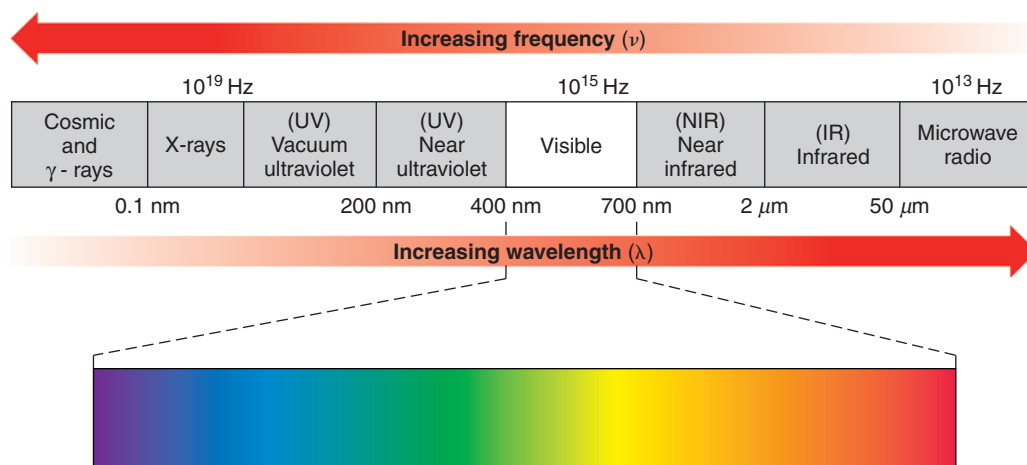

FIGURE 13.7 The electromagnetic spectrum.

13.8B UV-Vis Spectrophotometers

- A UV-Vis spectrophotometer (Fig. 13.8) measures the amount of light absorbed by a sample at each wavelength of the UV and visible regions of the electromagnetic spectrum.

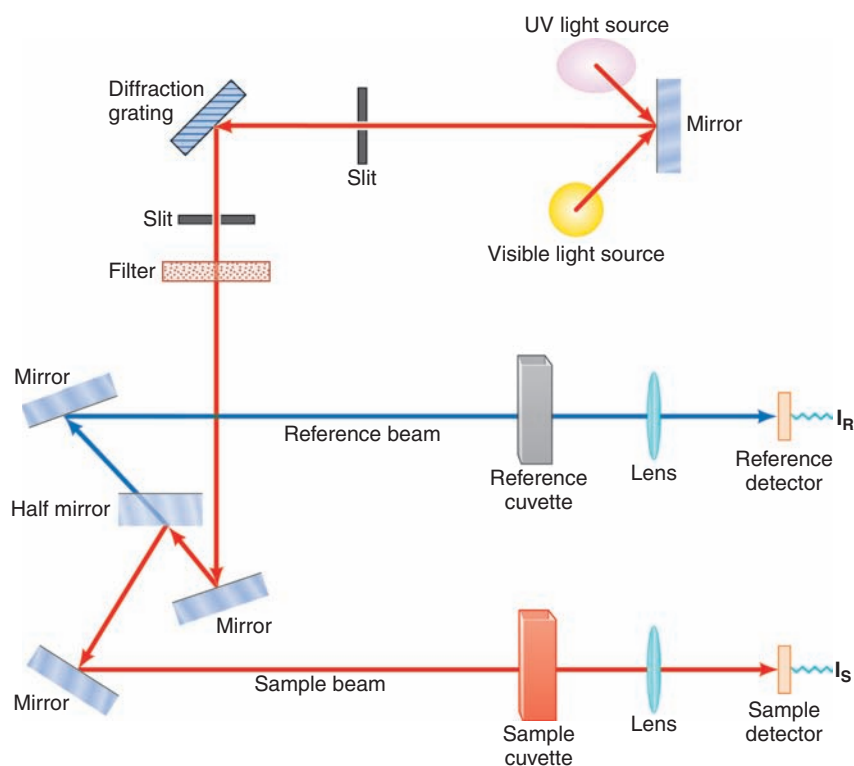

FIGURE 13.8 A diagram of a UV-Vis spectrophotometer.

(Courtesy William Reusch, <http://www2.chemistry.msu.edu/faculty/reusch/VirtTxtJml/Spectrpy/UV-Vis/uvspec.htm#uv1>. © 1999)



UV and visible radiation are of higher energy (shorter wavelength) than infrared radiation (used in IR spectroscopy) and radio frequency radiation (used in NMR) but not as energetic as X-radiation (Fig. 13.7).

In a standard UV-Vis spectrophotometer (Fig. 13.8) a beam of light is split; one half of the beam (the sample beam) is directed through a transparent cell containing a solution of the compound being analyzed, and one half (the reference beam) is directed through an identical cell that does not contain the compound but contains the solvent. Solvents are chosen to be transparent in the region of the spectrum being used for analysis. The instrument is designed so that it can make a comparison of the intensities of the two beams as it scans over the desired region of wavelengths. If the compound absorbs light at a particular wavelength, the intensity of the sample beam (I_S) will be less than that of the reference beam (I_R). The absorbance at a particular wavelength is defined by the equation $A_\lambda = \log(I_R/I_S)$.

- Data from a UV-Vis spectrophotometer are presented as an **absorption spectrum**, which is a graph of wavelength (λ) versus sample absorbance (A) at each wavelength in the spectral region of interest.

In diode-array UV-Vis spectrophotometers the absorption of all wavelengths of light in the region of analysis is measured simultaneously by an array of photodiodes. The absorption of the solvent is measured over all wavelengths of interest first, and then the absorption of the sample is recorded over the same range. Data from the solvent are electronically subtracted from the data for the sample. The difference is then displayed as the absorption spectrum for the sample.

A typical UV absorption spectrum, that of 2,5-dimethyl-2,4-hexadiene, is given in Fig. 13.9. It shows a broad absorption band in the region between 210 and 260 nm, with the maximum absorption at 242.5 nm.

- The wavelength of maximum absorption in a given spectrum is usually reported in the chemical literature as λ_{\max} .

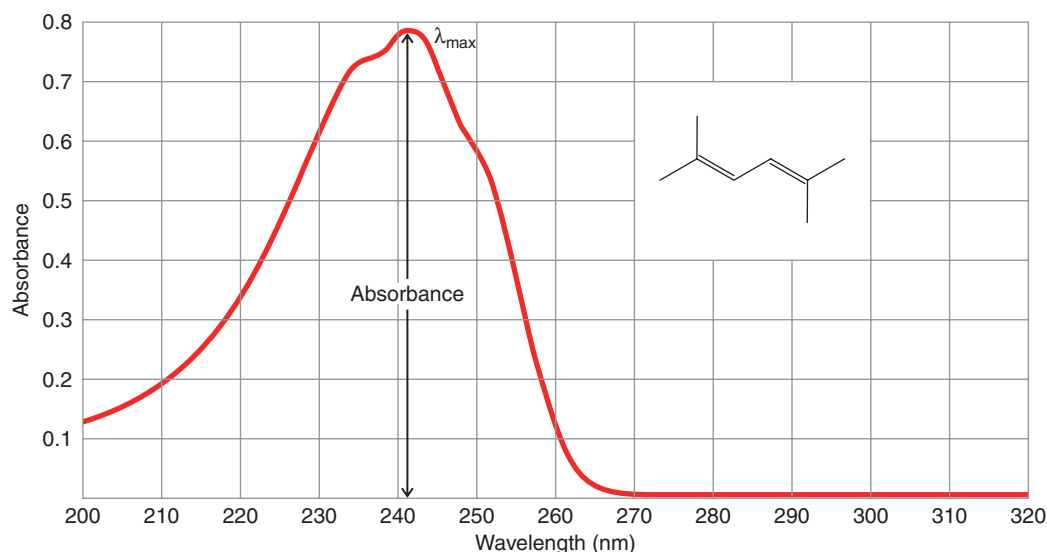

FIGURE 13.9 The UV absorption spectrum of 2,5-dimethyl-2,4-hexadiene in methanol at a concentration of 5.95×10^{-5} M in a 1.00-cm cell.

(©Bio-Rad Laboratories, Inc. Informatics Division, Sadtler Software & Databases. (2012) All Rights Reserved. Permission for the publication herein of Sadtler Spectra has been granted by Bio-Rad Laboratories, Inc., Informatics Division.)

In addition to reporting the wavelength of maximum absorption (λ_{\max}), chemists often report another quantity called the molar absorptivity, ϵ . In older literature, the molar absorptivity, ϵ , is often referred to as the molar extinction coefficient.

- The **molar absorptivity** (ϵ , in units of $M^{-1} \text{cm}^{-1}$) indicates the intensity of the absorbance for a sample at a given wavelength. It is a proportionality constant that relates absorbance to molar concentration of the sample (M) and the path length (l , in cm) of light through the sample.
- The equation that relates absorbance (A) to concentration (C) and path length (l) via molar absorptivity (ϵ) is called **Beer's law**.

$$A = \epsilon \times C \times l \quad \text{or} \quad \epsilon = \frac{A}{C \times l} \quad \text{Beer's law}$$

For 2,5-dimethyl-2,4-hexadiene dissolved in methanol the molar absorptivity at the wavelength of maximum absorbance (242.5 nm) is $13,100 M^{-1} \text{cm}^{-1}$. In the chemical literature this would be reported as

$$2,5\text{-Dimethyl-2,4-hexadiene, } \lambda_{\text{max}}^{\text{methanol}} 242.5 \text{ nm} \quad (\epsilon = 13,100)$$

13.8C Absorption Maxima for Nonconjugated and Conjugated Dienes

As we noted earlier, when compounds absorb light in the UV and visible regions, electrons are excited from lower electronic energy levels to higher ones. For this reason, visible and UV spectra are often called **electronic spectra**. The absorption spectrum of 2,5-dimethyl-2,4-hexadiene is a typical electronic spectrum because the absorption band (or peak) is very broad. Most absorption bands in the visible and UV region are broad because each electronic energy level has associated with it vibrational and rotational levels. Thus, electron transitions may occur from any of several vibrational and rotational states of one electronic level to any of several vibrational and rotational states of a higher level.

- Alkenes and nonconjugated dienes usually have absorption maxima (λ_{max}) below 200 nm.

Ethene, for example, gives an absorption maximum at 171 nm; 1,4-pentadiene gives an absorption maximum at 178 nm. These absorptions occur at wavelengths that are out of the range of operation of most ultraviolet–visible spectrometers because they occur where the oxygen in air also absorbs. Special air-free techniques must be employed in measuring them.

- Compounds containing *conjugated* multiple bonds have absorption maxima (λ_{max}) at wavelengths longer than 200 nm.

1,3-Butadiene, for example, absorbs at 217 nm. This longer wavelength absorption by conjugated dienes is a direct consequence of conjugation.

We can understand how conjugation of multiple bonds brings about absorption of light at longer wavelengths if we examine Fig. 13.10.

Helpful Hint

The λ_{max} in a UV–Vis spectrum can give evidence regarding presence of conjugated and nonconjugated π -electron systems.

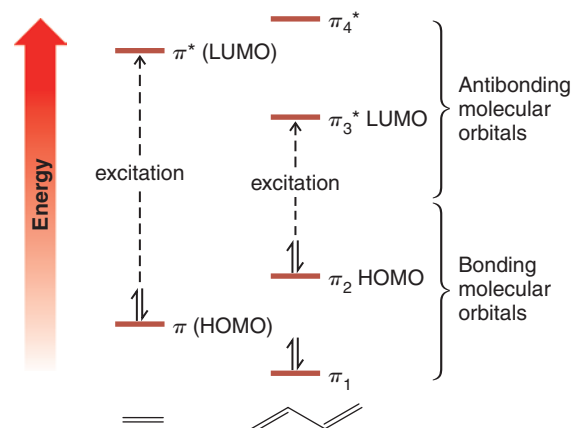

FIGURE 13.10 The relative energies of the π molecular orbitals of ethene and 1,3-butadiene (Section 13.6C).



- When a molecule absorbs light at its longest wavelength, an electron is excited from its **highest occupied molecular orbital (HOMO)** to the **lowest unoccupied molecular orbital (LUMO)**.
- For most alkenes and alkadienes the HOMO is a bonding π orbital and the LUMO is an antibonding π^* orbital.

The wavelength of the absorption maximum is determined by the difference in energy between these two levels. The energy gap between the HOMO and LUMO of ethene is greater than that between the corresponding orbitals of 1,3-butadiene. Thus, the $\pi \longrightarrow \pi^*$ electron excitation of ethene requires absorption of light of greater energy (shorter wavelength) than the corresponding $\pi_2 \longrightarrow \pi_3^*$ excitation in 1,3-butadiene. The energy difference between the HOMOs and the LUMOs of the two compounds is reflected in their absorption spectra. Ethene has its λ_{\max} at 171 nm; 1,3-butadiene has a λ_{\max} at 217 nm.

The narrower gap between the HOMO and the LUMO in 1,3-butadiene results from the conjugation of the double bonds. Molecular orbital calculations indicate that a much larger gap should occur in isolated alkadienes. This is borne out experimentally. Isolated alkadienes give absorption spectra similar to those of alkenes. Their λ_{\max} are at shorter wavelengths, usually below 200 nm. As we mentioned, 1,4-pentadiene has its λ_{\max} at 178 nm.

Conjugated alkatrienes absorb at longer wavelengths than conjugated alkadienes, and this too can be accounted for in molecular orbital calculations. The energy gap between the HOMO and the LUMO of an alkatriene is even smaller than that of an alkadiene.

- In general, *the greater the number of conjugated multiple bonds in a molecule, the longer will be its λ_{\max} .*

Polyenes with eight or more conjugated double bonds absorb light in the visible region of the spectrum. For example, β -carotene, a precursor of vitamin A and a compound that imparts its orange color to carrots, has 11 conjugated double bonds; β -carotene has an absorption maximum at 497 nm, well into the visible region. Light of 497 nm has a blue-green color; this is the light that is absorbed by β -carotene. We perceive the complementary color of blue-green, which is red-orange.

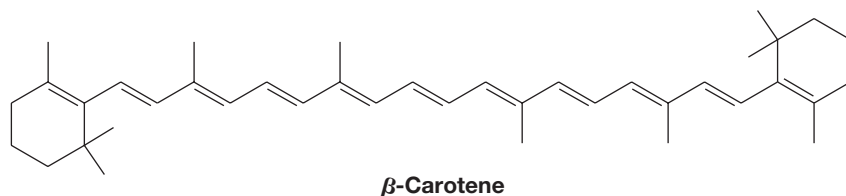

Lycopene, a compound partly responsible for the red color of tomatoes, also has 11 conjugated double bonds. Lycopene has an absorption maximum at 505 nm where it absorbs intensely. (Approximately 0.02 g of lycopene can be isolated from 1 kg of fresh, ripe tomatoes.)

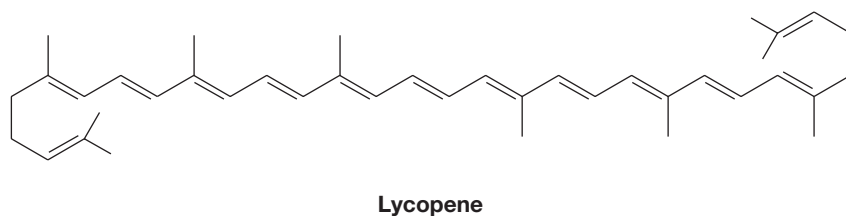

Table 13.3 gives the values of λ_{\max} for a number of unsaturated compounds.

TABLE 13.3 LONG-WAVELENGTH ABSORPTION MAXIMA OF UNSATURATED HYDROCARBONS

Compound	Structure	λ_{\max} (nm)	ϵ_{\max} ($M^{-1} \text{ cm}^{-1}$)
Ethene	$\text{CH}_2 = \text{CH}_2$	171	15,530
<i>trans</i> -3-Hexene		184	10,000
Cyclohexene		182	7,600
1-Octene		177	12,600
1-Octyne		185	2,000
1,3-Butadiene		217	21,000
<i>cis</i> -1,3-Pentadiene		223	22,600
<i>trans</i> -1,3-Pentadiene		223.5	23,000
But-1-en-3-yne		228	7,800
1,4-Pentadiene		178	17,000
1,3-Cyclopentadiene		239	3,400
1,3-Cyclohexadiene		256	8,000
<i>trans</i> -1,3,5-Hexatriene		274	50,000

Compounds with carbon–oxygen double bonds also absorb light in the UV region. Acetone, for example, has a broad absorption peak at 280 nm that corresponds to the excitation of an electron from one of the unshared pairs (a nonbonding or “ n ” electron) to the π^* orbital of the carbon–oxygen double bond:

Acetone

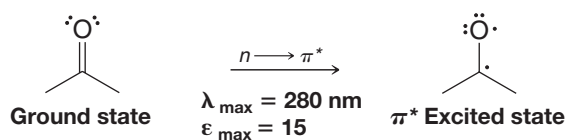

Compounds in which the carbon–oxygen double bond is conjugated with a carbon–carbon double bond have absorption maxima corresponding to $n \rightarrow \pi^*$ excitations and $\pi \rightarrow \pi^*$ excitations. The $n \rightarrow \pi^*$ absorption maxima occur at longer wavelengths but are much weaker (i.e., have smaller molar absorptivity (ϵ) values):

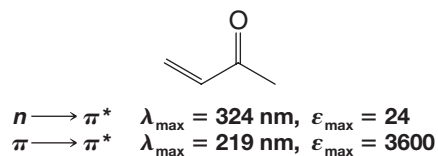

13.8D Analytical Uses of UV–Vis Spectroscopy

UV–Vis spectroscopy can be used in the structure elucidation of organic molecules to indicate whether conjugation is present in a given sample. Although conjugation in a



molecule may be indicated by data from IR, NMR, or mass spectrometry, UV-Vis analysis can provide corroborating information.

A more widespread use of UV-Vis spectroscopy, however, has to do with determining the concentration of an unknown sample. As mentioned in Section 13.8B, the relationship $A = \epsilon Cl$ indicates that the amount of absorption by a sample at a certain wavelength is dependent on its concentration. This relationship is usually linear over a range of concentrations suitable for analysis. To determine the unknown concentration of a sample, a graph of absorbance versus concentration is made for a set of standards of known concentrations. The wavelength used for analysis is usually the λ_{\max} of the sample. The concentration of the sample is obtained by measuring its absorbance and determining the corresponding value of concentration from the graph of known concentrations. Quantitative analysis using UV-Vis spectroscopy is routinely used in biochemical studies to measure the rates of enzymatic reactions. The concentration of a species involved in the reaction (as related to its UV-Vis absorbance) is plotted versus time to determine the rate of reaction. UV-Vis spectroscopy is also used in environmental chemistry to determine the concentration of various metal ions (sometimes involving absorption spectra for organic complexes with the metal) and as a detection method in high-performance liquid chromatography (HPLC).

SOLVED PROBLEM 13.7

Two isomeric compounds, **A** and **B**, have the molecular formula C_7H_{12} . Compound **A** shows no absorption in the UV-visible region. The ^{13}C NMR spectrum of **A** shows only three signals. Compound **B** shows a UV-visible peak in the region of 180 nm, its ^{13}C NMR spectrum shows four signals, and its DEPT ^{13}C NMR data show that none of its carbon atoms is a methyl group. On catalytic hydrogenation with excess hydrogen, **B** is converted to heptane. Propose structures for **A** and **B**.

STRATEGY AND ANSWER: On the basis of their molecular formulas, both compounds have an index of hydrogen deficiency (Section 4.17) equal to 2. Therefore on this basis alone, each could contain two double bonds, one ring and one double bond, two rings, or a triple bond. Consider **A** first. The fact that **A** does not absorb in the UV-visible region suggests that it does not have any double bonds; therefore, it must contain two rings. A compound with two rings that would give only three signals in its ^{13}C spectrum is bicyclo[2.2.1]heptane (because it has only three distinct types of carbon atoms).

Now consider **B**. The fact that **B** is converted to heptane on catalytic hydrogenation suggests that **B** is a heptadiene or a heptyne with an unbranched chain. UV-visible absorption in the 180-nm region suggests that **B** does not contain conjugated π bonds. Given that the DEPT ^{13}C data for **B** shows the absence of any methyl groups, and only four ^{13}C signals in total, **B** must be 1,6-hexadiene.

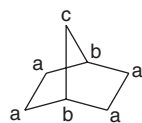

A

Bicyclo[2.2.1]heptane
(three ^{13}C signals)

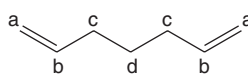

B

1,6-Hexadiene
(four ^{13}C signals,
none comes from a methyl group)

Two compounds, **A** and **B**, have the same molecular formula, C_6H_8 . Both **A** and **B** react with two molar equivalents of hydrogen in the presence of platinum to yield cyclohexane. Compound **A** shows three signals in its broadband decoupled ^{13}C NMR spectrum. Compound **B** shows only two ^{13}C NMR signals. Compound **A** shows an absorption maximum at 256 nm, whereas **B** shows no absorption maximum at wavelengths longer than 200 nm. What are the structures of **A** and **B**?

PRACTICE PROBLEM 13.7

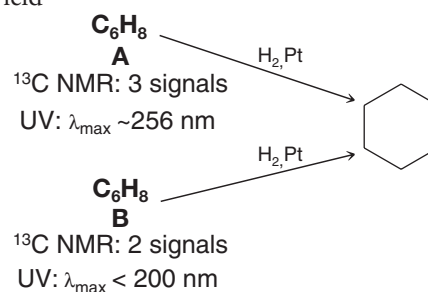

PRACTICE PROBLEM 13.8 Propose structures for **D**, **E**, and **F**.

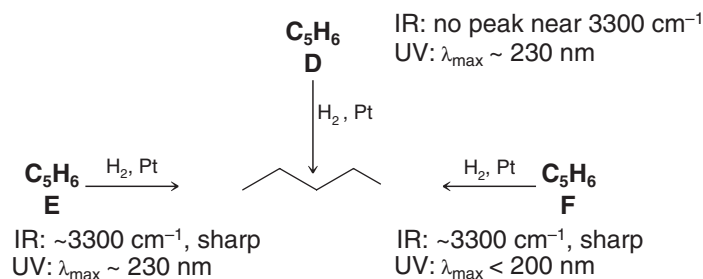

13.9 ELECTROPHILIC ATTACK ON CONJUGATED DIENES: 1,4-ADDITION

Not only are conjugated dienes somewhat more stable than nonconjugated dienes, they also display special behavior when they react with electrophilic reagents.

- Conjugated dienes undergo both 1,2- and 1,4-addition through an allylic intermediate that is common to both.

For example, 1,3-butadiene reacts with one molar equivalent of hydrogen chloride to produce two products, 3-chloro-1-butene and 1-chloro-2-butene:

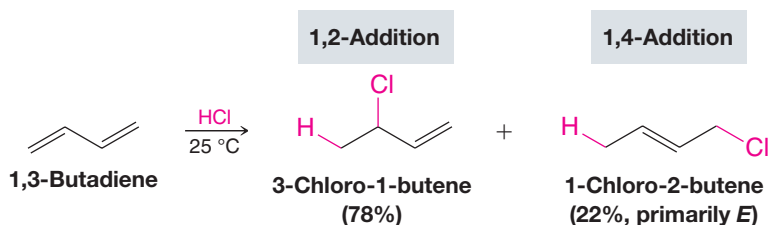

If only the first product (3-chloro-1-butene) were formed, we would not be particularly surprised. We would conclude that hydrogen chloride had added to one double bond of 1,3-butadiene in the usual way. It is the second product, 1-chloro-2-butene, that is initially surprising. Its double bond is between the central atoms, and the elements of hydrogen chloride have added to the C1 and C4 atoms.

To understand how both 1,2- and 1,4-addition products result from reaction of 1,3-butadiene with HCl, consider the following mechanism.

Step 1

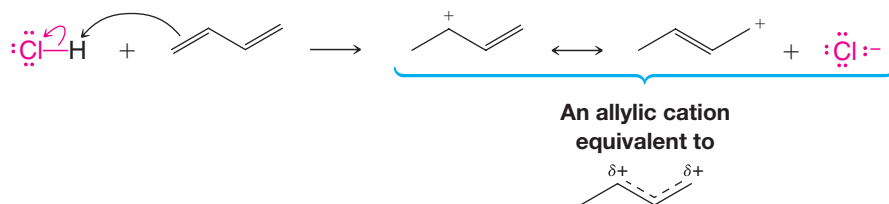

Step 2

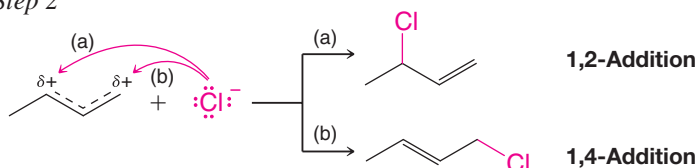

In step 1 a proton adds to one of the terminal carbon atoms of 1,3-butadiene to form, as usual, the more stable carbocation, in this case a resonance-stabilized allylic cation.



Addition to one of the inner carbon atoms would have produced a much less stable primary cation, one that could not be stabilized by resonance:

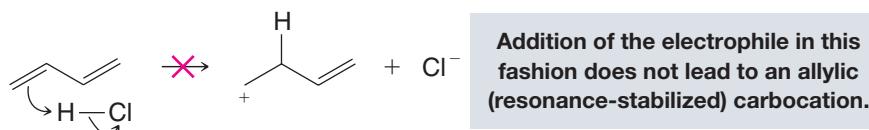

In step 2 a chloride ion forms a bond to one of the carbon atoms of the allylic cation that bears a partial positive charge. Reaction at one carbon atom results in the 1,2-addition product; reaction at the other gives the 1,4-addition product.

Note that the designations 1,2 and 1,4 only coincidentally relate to the IUPAC numbering of carbon atoms in this example.

- Chemists typically use 1,2 and 1,4 to refer to modes of addition to any conjugated diene system, regardless of where the conjugated double bonds are in the overall molecule.

Thus, addition reactions of 2,4-hexadiene would still involve references to 1,2 and 1,4 modes of addition.

Predict the products of the following reactions.



●●●
PRACTICE PROBLEM 13.9

1,3-Butadiene shows 1,4-addition reactions with electrophilic reagents other than hydrogen chloride. Two examples are shown here, the addition of hydrogen bromide (in the absence of peroxides) and the addition of bromine:

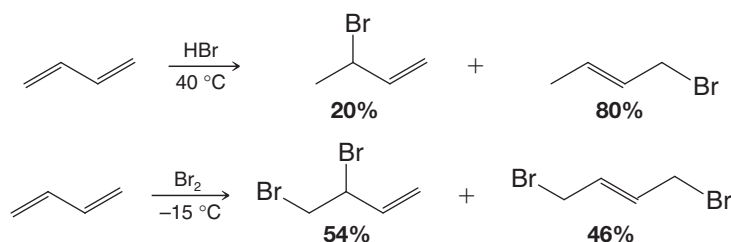

Reactions of this type are quite general with other conjugated dienes. Conjugated trienes often show 1,6-addition. An example is the 1,6-addition of bromine to 1,3,5-cyclooctatriene:

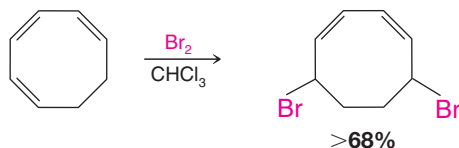

13.9A Kinetic Control versus Thermodynamic Control of a Chemical Reaction

The addition of hydrogen bromide to 1,3-butadiene allows the illustration of another important aspect of reactivity—the way temperature affects product distribution in a reaction that can take multiple paths. In general:

- The favored products in a reaction at *lower temperature* are those formed by the pathway having the smallest energy of activation barrier. In this case the reaction is said to be under **kinetic (or rate) control**, and the predominant products are called the **kinetic products**.
- The favored products at *higher temperature* in a *reversible* reaction are those that are most stable. In this case the reaction is said to be under **thermodynamic (or equilibrium) control**, and the predominant products are called the **thermodynamic (or equilibrium) products**.

Let's consider specific reaction conditions for the ionic addition of hydrogen bromide to 1,3-butadiene.

Case 1. When 1,3-butadiene and hydrogen bromide react at low temperature (-80°C), the major product is formed by 1,2-addition. We obtain 80% of the 1,2-product and 20% of the 1,4-product.

Case 2. When 1,3-butadiene and hydrogen bromide react at high temperature (40°C), the major product is formed by 1,4-addition. We obtain about 20% of the 1,2-product and about 80% of the 1,4-product.

Case 3. When the product mixture from the low temperature reaction is warmed to the higher temperature, the product distribution becomes the same as when the reaction was carried out at high temperature—that is, the 1,4-product predominates.

We summarize these scenarios here:

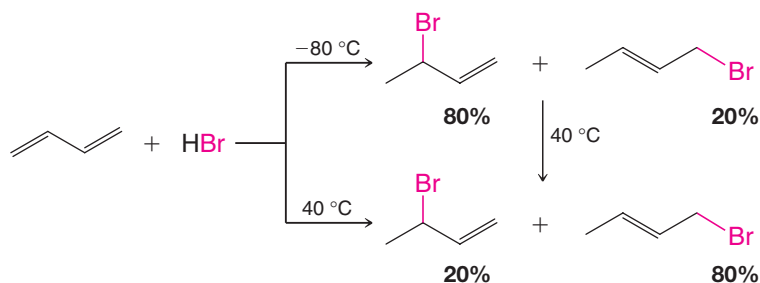

Furthermore, when a pure sample of 3-bromo-1-butene (the predominant product at low temperature) is subjected to the high temperature reaction conditions, an equilibrium mixture results in which the 1,4-addition product predominates.

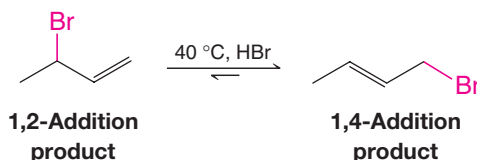

Because this equilibrium favors the 1,4-addition product, *that product must be more stable*.

The reactions of hydrogen bromide with 1,3-butadiene serve as a striking illustration of the way that the outcome of a chemical reaction can be determined, in one instance, by relative rates of competing reactions and, in another, by the relative stabilities of the final products. At the lower temperature, the relative amounts of the products of the addition are determined by the relative rates at which the two additions occur; 1,2-addition occurs faster so the 1,2-addition product is the major product. At the higher temperature, the relative amounts of the products are determined by the position of an equilibrium. The 1,4-addition product is the more stable, so it is the major product.

This behavior of 1,3-butadiene and hydrogen bromide can be more fully understood if we examine the diagram shown in Fig. 13.11.

- The step that determines the overall outcome of this reaction is the step in which the hybrid allylic cation combines with a bromide ion.

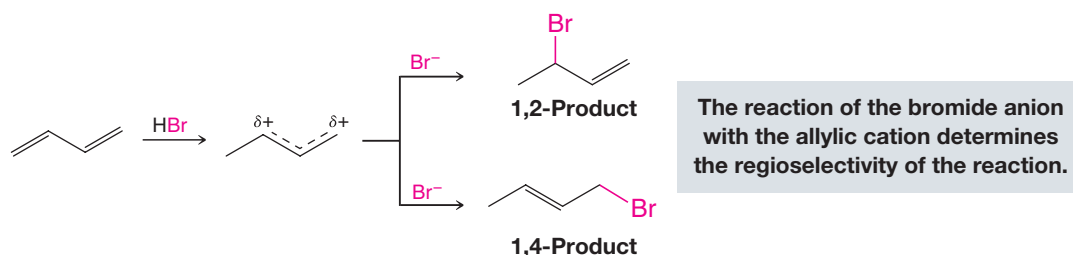

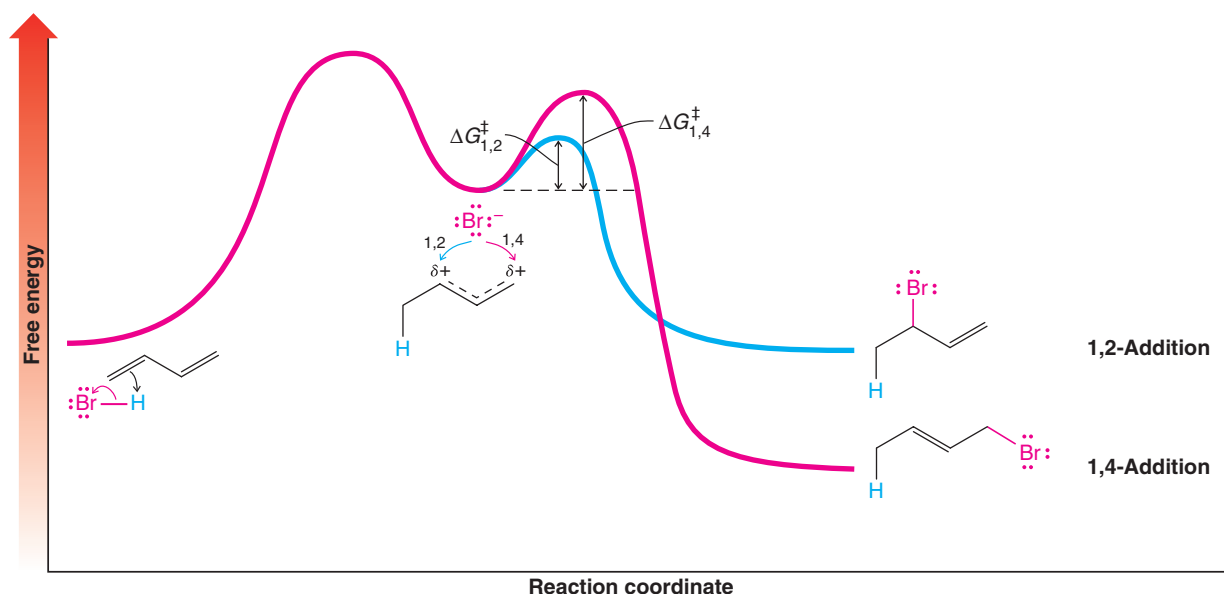
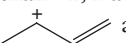
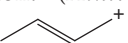

FIGURE 13.11 A schematic free-energy versus reaction coordinate diagram for the 1,2- and 1,4-addition of HBr to 1,3-butadiene. An allylic carbocation is common to both pathways. The energy barrier for attack of bromide ion on the allylic cation to form the 1,2-addition product is less than that to form the 1,4-addition product. The 1,2-addition product is kinetically favored. The 1,4-addition product is more stable, and so it is the thermodynamically favored product.

We see in Fig. 13.11 that the free energy of activation leading to the 1,2-addition product is less than the free energy of activation leading to the 1,4-addition product, even though the 1,4-product is more stable.

- At **low temperature**, the fraction of collisions capable of surmounting the higher energy barrier leading to formation of the 1,4-product is smaller than the fraction that can cross the barrier leading to the 1,2-product.
- At low temperature, formation of the 1,2- and 1,4-products is essentially *irreversible* because there is not enough energy for either product to cross back over the barrier to reform the allylic cation. Thus, the 1,2-product predominates at lower temperature because it is formed faster and it is not formed reversibly. It is the **kinetic product** of this reaction.
- At **higher temperature**, collisions between the intermediate ions are sufficiently energetic to allow rapid formation of *both* the 1,2- and 1,4-products. *But*, there is also sufficient energy for both products to revert to the **allylic carbocation**.
- Because the 1,2-product has a smaller energy barrier for conversion back to the allylic cation than does the 1,4-product, more of the 1,2-product reverts to the allylic cation than does the 1,4-product. But since both the 1,4- and the 1,2-products readily form from the allylic cation at high temperature, eventually this equilibrium leads to a preponderance of the 1,4-product because it is more stable. The 1,4-product is the **thermodynamic** or **equilibrium product** of this reaction.

Before we leave this subject, one final point should be made. This example clearly demonstrates that predictions of relative reaction rates made on the basis of product stabilities alone can be wrong. This is not always the case, however. For many reactions in which a common intermediate leads to two or more products, the most stable product is formed fastest.

- (a) Suggest a structural explanation for the fact that the 1,2-addition reaction of 1,3-butadiene and hydrogen bromide occurs faster than 1,4-addition? (*Hint*: Consider the relative contributions that the two forms  and  make to the resonance hybrid of the allylic cation.)
- (b) How can you account for the fact that the 1,4-addition product is more stable?

PRACTICE PROBLEM 13.10

13.10 THE DIELS–ALDER REACTION: A 1,4-CYCLOADDITION REACTION OF DIENES



In 1928 two German chemists, Otto Diels and Kurt Alder, developed a **1,4-cycloaddition** reaction of dienes that has since come to bear their names. The reaction proved to be one of such great versatility and synthetic utility that Diels and Alder were awarded the Nobel Prize in Chemistry in 1950.

An example of the Diels–Alder reaction is the reaction that takes place when 1,3-butadiene and maleic anhydride are heated together at 100°C. The product is obtained in quantitative yield:

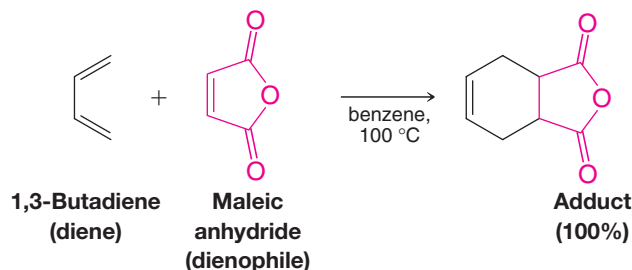

- In general terms, the **Diels–Alder reaction** is one between a conjugated **diene** (a 4π -electron system) and a compound containing a double bond (a 2π -electron system) called a **dienophile** (diene + *philia*, Greek: to love). The product of a Diels–Alder reaction is often called an **adduct**.

Helpful Hint

The Diels–Alder reaction is a very useful synthetic tool for preparing cyclohexene rings.

In the Diels–Alder reaction, two new σ bonds are formed at the expense of two π bonds of the diene and dienophile. The adduct contains a new six-membered ring with a double bond. Since σ bonds are usually stronger than π bonds, formation of the adduct is usually favored energetically, *but most Diels–Alder reactions are reversible*.

We can account for all of the bond changes in a Diels–Alder reaction like that above by using curved arrows in the following way:

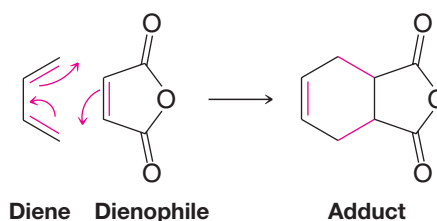

The Diels–Alder reaction is an example of a **pericyclic reaction** (see Special Topic H in *WileyPLUS*). **Pericyclic reactions are concerted reactions that take place in one step through a cyclic transition state in which symmetry characteristics of molecular orbitals control the course of the reaction.**

We will discuss the mechanism of the Diels–Alder reaction in terms of molecular orbitals in Special Topic H in *WileyPLUS*. For the moment we will continue to describe the Diels–Alder reaction using bonds and curved arrows to describe the movement of electrons that take place.

The simplest example of a Diels–Alder reaction is the one that takes place between 1,3-butadiene and ethene. This reaction, however, takes place much more slowly than the reaction of butadiene with maleic anhydride and also must be carried out under pressure:

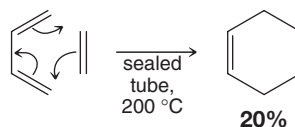



Another example is the preparation of an intermediate in the synthesis of the anticancer drug Taxol (paclitaxel) by K. C. Nicolaou (The Scripps Research Institute and the University of California, San Diego):

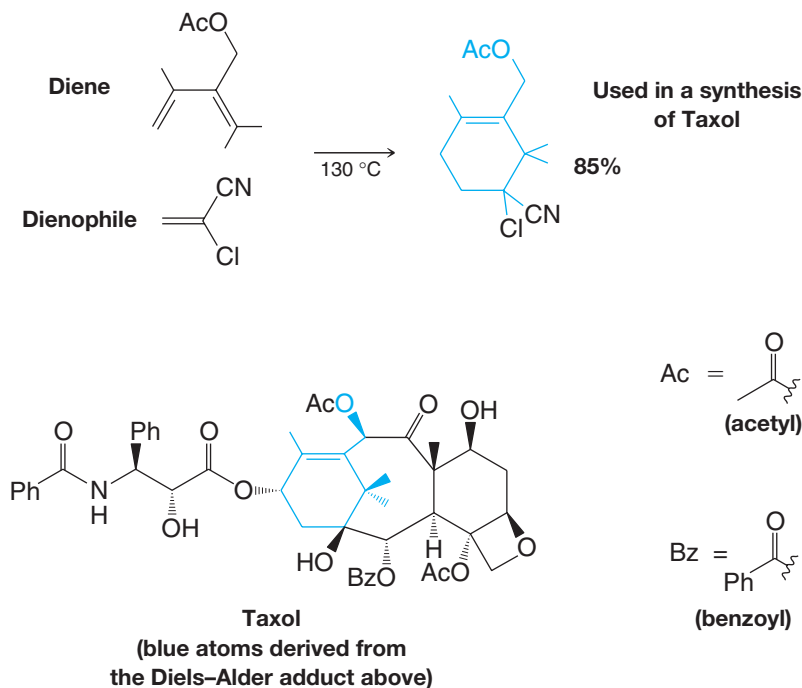

In general, the dienophile reacts with a conjugated diene by 1,4-addition to form a six-membered ring. The process is called a [4+2] **cycloaddition**, named according to the number of atoms from each reactant that join to form the ring, and it is brought about by heat (a thermal reaction). Any position on either side of the diene or dienophile can be substituted. Some representative electron-withdrawing groups that can be part of the dienophile are shown below as Z and Z'.

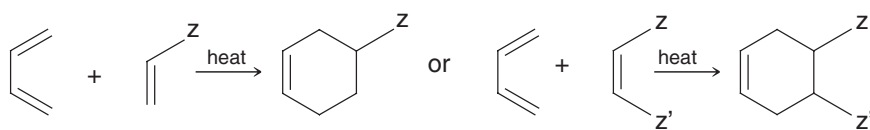

Where Z and Z' can be CHO, COR, CO₂H, CO₂R, CN, Ar, CO-O-CO, or halogen, as well as others.

Pericyclic reactions in which two alkenes combine in the following way are also known.

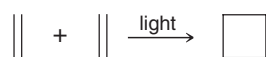

These are called [2 + 2] cycloadditions and require light energy (they are photochemical reactions). We discuss them in Special Topic H in *WileyPLUS*.

13.10A Factors Favoring the Diels–Alder Reaction

Alder originally stated that the Diels–Alder reaction is favored by the presence of electron-withdrawing groups in the dienophile and by electron-releasing groups in the diene. Maleic anhydride, a very potent dienophile, has two electron-withdrawing carbonyl groups on carbon atoms adjacent to the double bond.

The helpful effect of electron-releasing groups in the diene can also be demonstrated; 2,3-dimethyl-1,3-butadiene, for example, is nearly five times as reactive in Diels–Alder reactions as is 1,3-butadiene. The methyl groups inductively release electron density, just

as alkyl groups do when stabilizing a carbocation (though no carbocations are involved here). When 2,3-dimethyl-1,3-butadiene reacts with propenal (acrolein) at only 30°C, the adduct is obtained in quantitative yield:

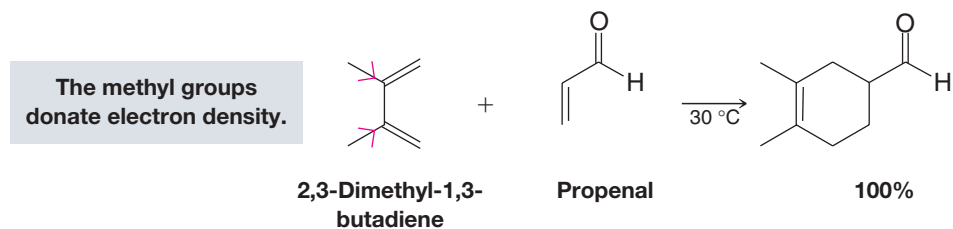

Research (by C. K. Bradsher of Duke University) has shown that the locations of electron-withdrawing and electron-releasing groups in the dienophile and diene can be reversed without reducing the yields of the adducts. Dienes with electron-withdrawing groups have been found to react readily with dienophiles containing electron-releasing groups.

Besides the use of dienes and dienophiles that have complementary electron-releasing and electron-donating properties, other factors found to enhance the rate of Diels–Alder reactions include high temperature and high pressure. Another widely used method is the use of Lewis acid catalysts. The following reaction is one of many examples where Diels–Alder adducts form readily at ambient temperature in the presence of a Lewis acid catalyst. (In Section 13.10C we see how Lewis acids can be used with chiral ligands to induce asymmetry in the reaction products.)

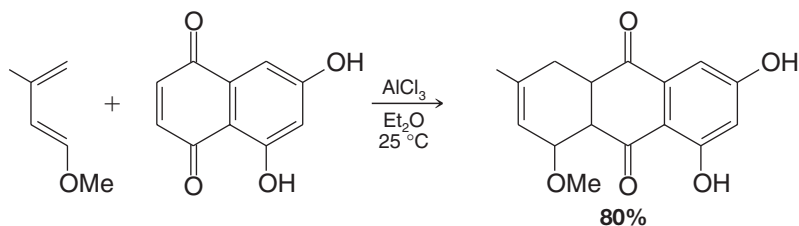

13.10B Stereochemistry of the Diels–Alder Reaction

Now let us consider some stereochemical aspects of the Diels–Alder reaction. The following factors are among the reasons why Diels–Alder reactions are so extraordinarily useful in synthesis.

1. **The Diels–Alder reaction is stereospecific: the reaction is a syn addition, and the configuration of the dienophile is retained in the product.** Two examples that illustrate this aspect of the reaction are shown here:

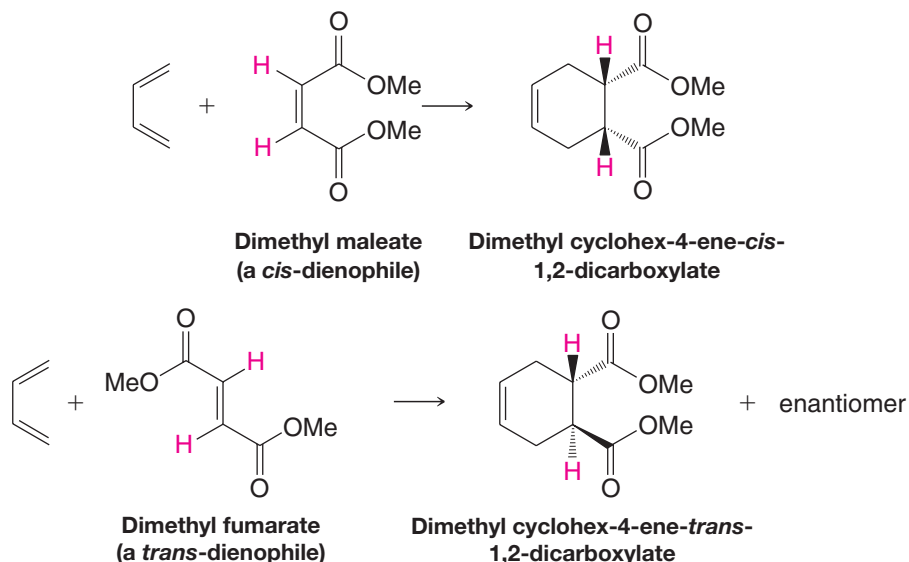



In the first example, a dienophile with *cis* ester groups reacts with 1,3-butadiene to give an adduct with *cis* ester groups. In the second example just the reverse is true. A *trans*-dienophile gives a *trans* adduct.

2. The diene, of necessity, reacts in the *s-cis* rather than in the *s-trans* conformation:

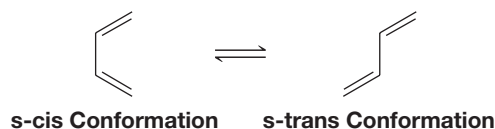

Reaction in the *s-trans* conformation would, if it occurred, produce a six-membered ring with a highly strained *trans* double bond. This course of the Diels–Alder reaction has never been observed.

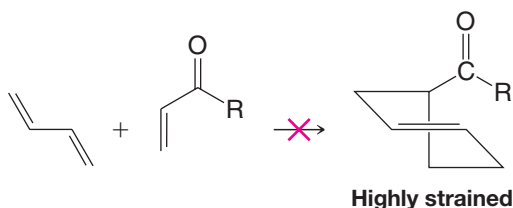

Helpful Hint

Use handheld molecular models to investigate the strained nature of hypothetical *trans*-cyclohexene.

Cyclic dienes in which the double bonds are held in the *s-cis* conformation are usually highly reactive in the Diels–Alder reaction. Cyclopentadiene, for example, reacts with maleic anhydride at room temperature to give the following adduct in quantitative yield:

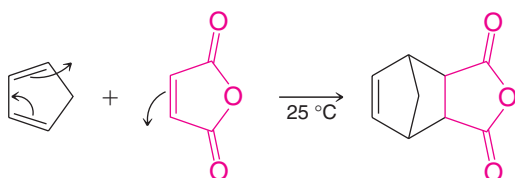

Cyclopentadiene is so reactive that on standing at room temperature it slowly undergoes a Diels–Alder reaction with itself:

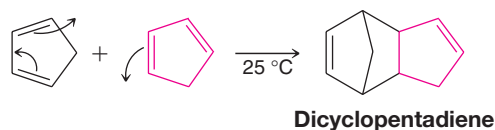

The reaction is reversible, however. When dicyclopentadiene is distilled, it dissociates (is “cracked”) into two molar equivalents of cyclopentadiene.

The reactions of cyclopentadiene illustrate a third stereochemical characteristic of the Diels–Alder reaction.

3. The Diels–Alder reaction occurs primarily in an *endo* rather than an *exo* fashion when the reaction is kinetically controlled.

A dienophile often contains an electron-withdrawing group, such as a carbonyl or other electronegative group with π electrons, as in the example below and in all of the examples we have shown thus far.

- In Diels–Alder reactions, *endo* and *exo* refer to the orientation of the dienophile and its electron-withdrawing group when it reacts with the diene.
- When the dienophile reacts such that the π electron orbitals of its electron-withdrawing group align under (or above) the π electron orbitals of the diene, the orientation of approach is called **endo**.
- When the electron-withdrawing group of the dienophile is aligned away from the π electrons of the diene in the transition state, the orientation of approach is called **exo**.
- When a Diels–Alder reaction takes place, products from both the *endo* and *exo* transition states can be formed, but the *endo* product typically predominates because the *endo* transition state is usually of lower energy.

Although we shall not discuss the details here, the reason that the endo approach is generally favored has to do with orbital overlap that lowers the transition state energy in the endo orientation. For this reason, the endo product is formed faster (it is the kinetic product).

Consider the example in Figure 13.12 involving (2*E*,4*E*)-hexa-2,4-diene and methyl propenoate. Note that the manner of approach, endo or exo, affects the product stereochemistry of the electron-withdrawing group from the dienophile.

(a)

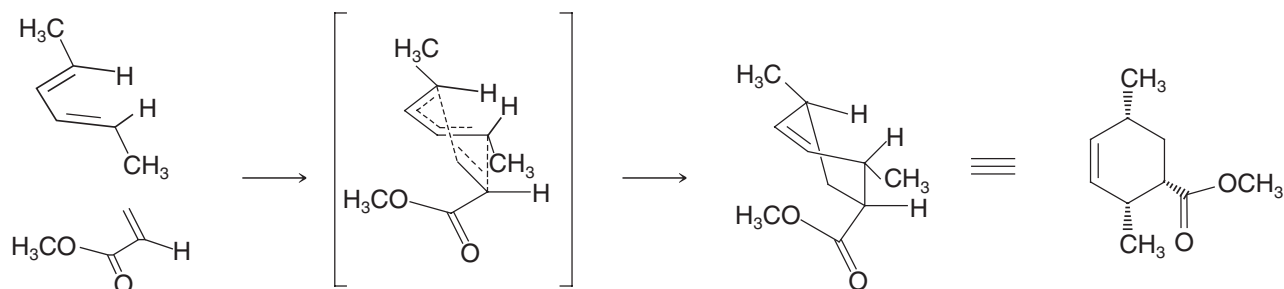

(plus enantiomer)

Endo approach: the dienophile aligns with its electron-withdrawing substituent underneath the π system, as shown, or directly above it (not shown). The two possible endo approaches lead to enantiomers.

(b)

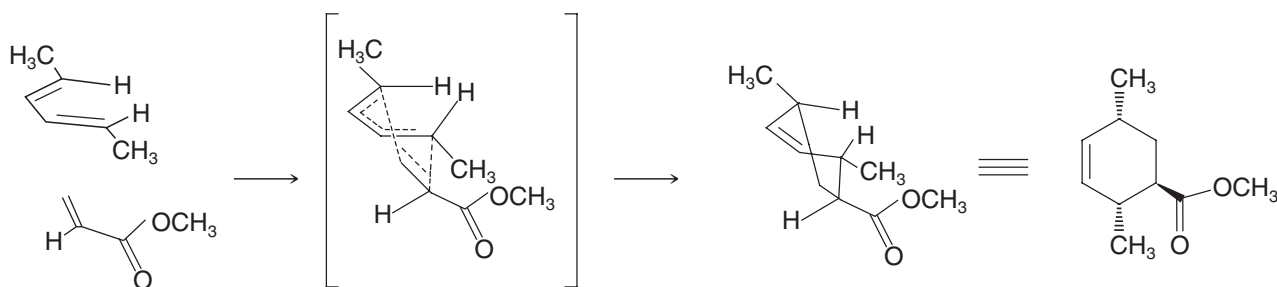

(plus enantiomer)

Exo approach: the dienophile aligns with its electron-withdrawing substituent below and away from the diene π system, as shown, or above it and away (not shown). The two possible exo approaches lead to enantiomers.

FIGURE 13.12 The Diels-Alder reaction of (2*E*,4*E*)-hexa-2,4-diene and methyl propenoate showing (a) endo and (b) exo approaches. The endo transition state is favored over exo because the π electron orbitals of the electron-withdrawing group in the dienophile align closer to the π electron orbitals of the diene.

Although in both the endo and exo examples that we have shown in Figure 13.12 the dienophile approaches the diene from below, the dienophile can also approach the diene from above, which is why the enantiomer of the product that we have drawn is formed in each case. In general, Diels-Alder reactions result in the formation of enantiomers unless one or both of the reactants is chiral or there is an influence from a chiral catalyst.

PRACTICE PROBLEM 13.11

Draw transition states for the endo and exo Diels-Alder reaction of maleic anhydride with cyclopentadiene. The transition state leading to only one enantiomer need be shown in each case.



PRACTICE PROBLEM 13.12

If we were to write a chemical equation for the reaction of $(2E,4E)$ -hexa-2,4-diene and methyl propenoate we might write it as shown below. **(a)** Explain why we can predict that the endo and exo products will each be formed as a pair of enantiomers. **(b)** What is the stereochemical relationship between either one of the endo enantiomers and either of the exo enantiomers?

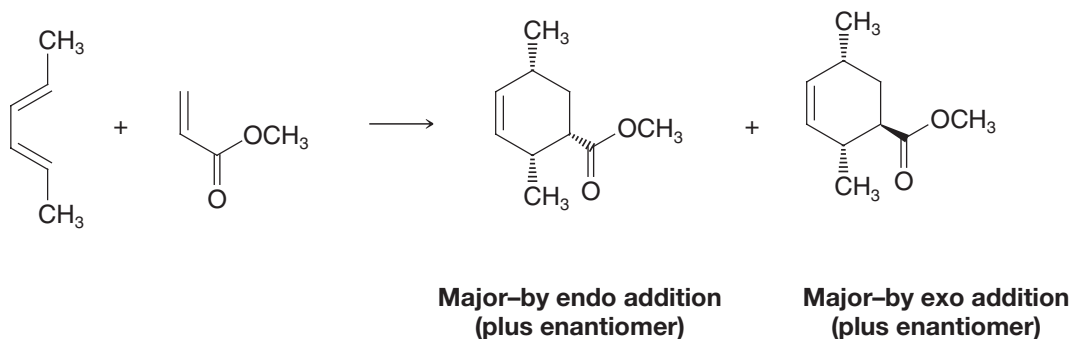

The terms endo and exo are also used to designate the orientation of substituents at tetrahedral carbons in the bridges of bicyclic ring systems.

- In a bicyclic system, a substituent is exo if the bond attaching it to the bridge is oriented away from the longest of the two remaining bridges in the system, and endo if the bond to the substituent is oriented toward the longest of the two remaining bridges.

The following illustration shows an R group in an exo position and an endo position.

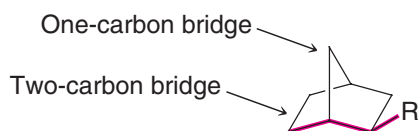

**R is exo
(oriented away from the longest bridge)**

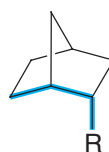

**R is endo
(oriented closer to the longest bridge)**

Consider the Diels–Alder reaction of cyclopentadiene with methyl propenoate shown below. The ester group in the major product is endo because the ester substituent is oriented closer to the two-carbon (the longer) bridge than to the one-carbon (shorter) bridge. In the minor product the ester substituent is exo because it is oriented away from the longest bridge.

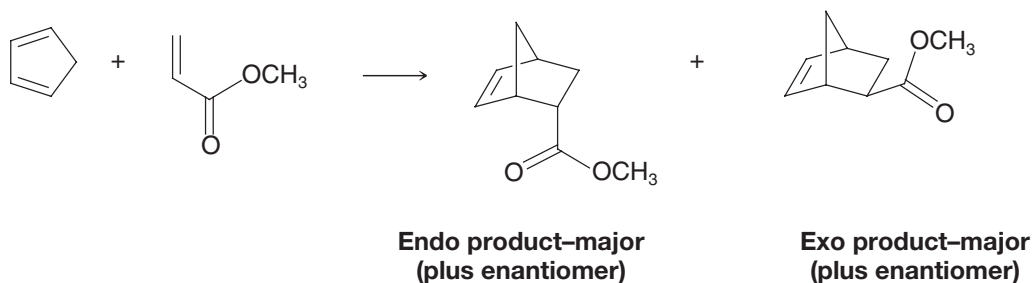

4. **The configuration of the diene is retained in a Diels–Alder reaction.** Just as the configuration of the dienophile is retained in the adduct of a Diels–Alder reaction (see 1 above), the configuration of the diene is also retained. What we mean is that the E,Z alkene stereochemistry of both the diene and the dienophile are transferred

to new tetrahedral chirality centers in the Diels–Alder adduct. Consider the reactions below of maleic anhydride with $(2E,4E)$ -hexa-2,4-diene, and with the alkene diastereomer and $(2E,4Z)$ -hexa-2,4-diene, showing the endo (major) product in each case.

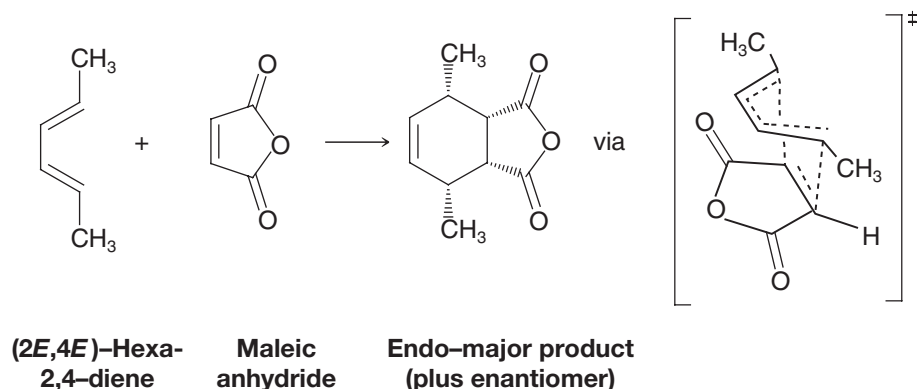

When the diene stereochemistry is changed, the stereochemistry of the adduct differs accordingly, as shown below.

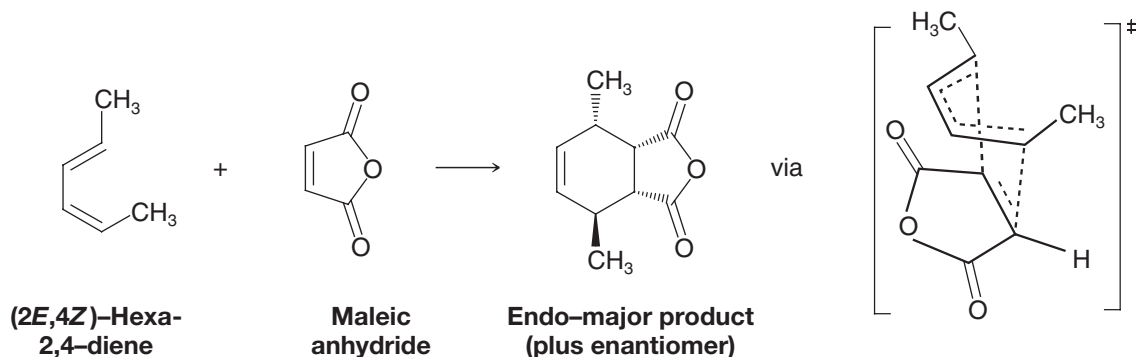

If the diene substituents are both on the outside of the diene component when the diene is in the *s-cis* conformation the substituents will be *cis*.

Consideration of the transition states for each reaction, as given above, helps to show how the stereochemistry is transferred from the diene to the adduct in each case.

PRACTICE PROBLEM 13.13

If $(2Z,4Z)$ -hexa-2,4-diene were able to undergo a Diels–Alder reaction with methyl propenoate, what would be the products? (*Hint*: There are four products comprised of two pairs of enantiomers. One enantiomer pair would predominate.) In reality, this Diels–Alder reaction is impractical because the *s-cis* conformation of the diene required for the reaction is of high energy due to steric hindrance between the methyl groups.

13.10C HOW TO Predict the Products of a Diels–Alder Reaction

Problem: Predict the product of the Diels–Alder reaction between the following compounds.

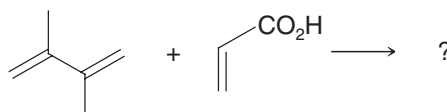



Strategy and Solution: Draw the diene component in the *s-cis* conformation so that the ends of both double bonds are near the double bond of the dienophile. Then show the movement of electron pairs that will convert the two molecules into one cyclic molecule.

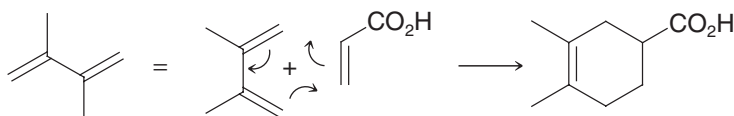

13.10D HOW TO Use a Diels–Alder Reaction in a Retrosynthetic Analysis

Problem: Outline a stereospecific synthesis of the all-*cis* stereoisomer of 1,2,3,4-tetramethylcyclohexane (that is, where the methyl groups are all on the same side of the ring).

Retrosynthetic Analysis and Solution: Devising this synthesis will help you see how a Diels–Alder reaction can be used to impart specific stereochemistry in a synthesis. It will also help you review some other reactions you have just learned. Here is our retrosynthetic scheme:

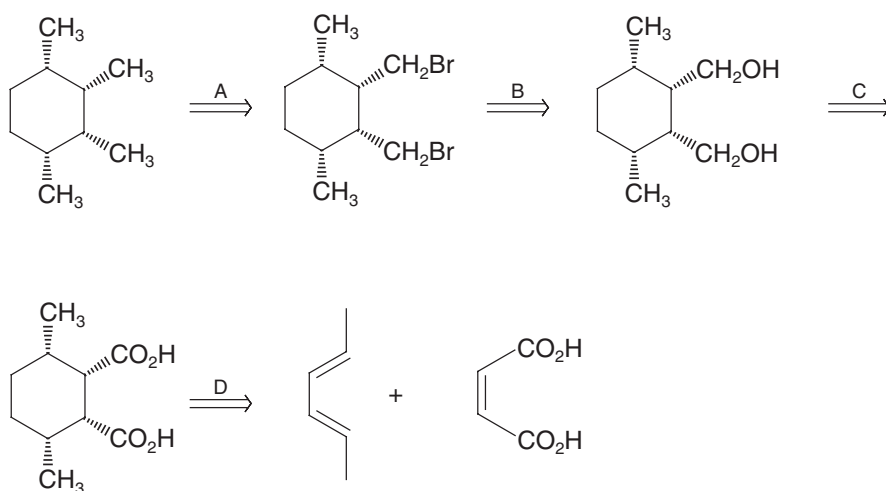

Here is our synthesis. We use a Diels–Alder reaction to create a six-membered ring with the all-*cis* stereochemistry from the endo product. Then we convert the two $\text{—CO}_2\text{H}$ groups to $\text{—CH}_2\text{OH}$ groups, then to $\text{—CH}_2\text{Br}$ groups, and finally to —CH_3 groups.

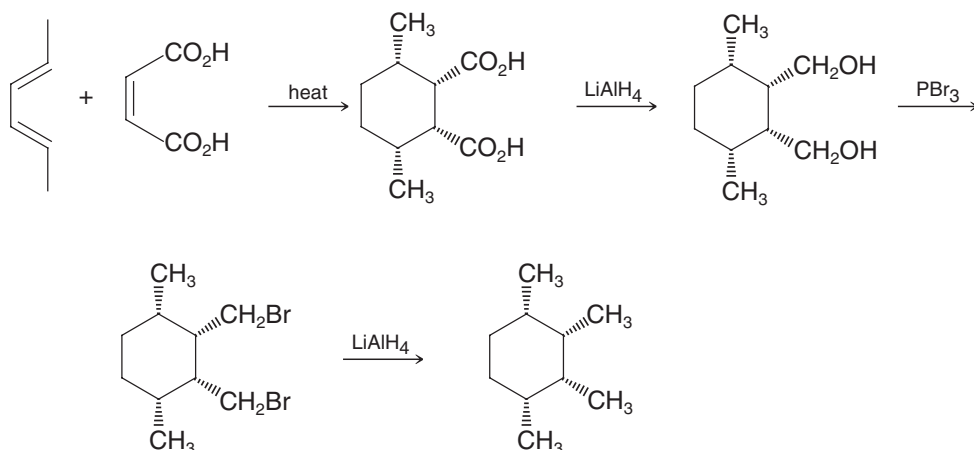

PRACTICE PROBLEM 13.14 What products would you expect from the following reactions?

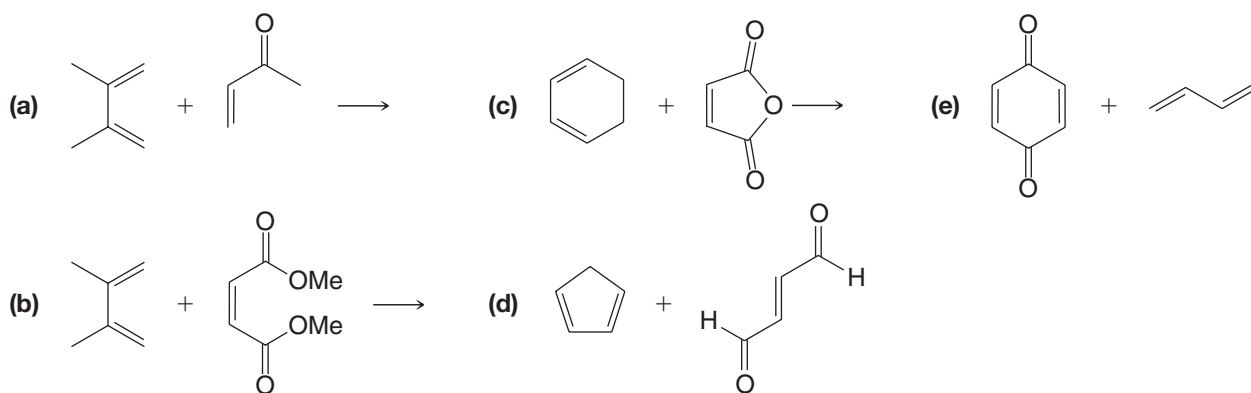

PRACTICE PROBLEM 13.15 Which diene and dienophile would you employ to synthesize the following compounds?

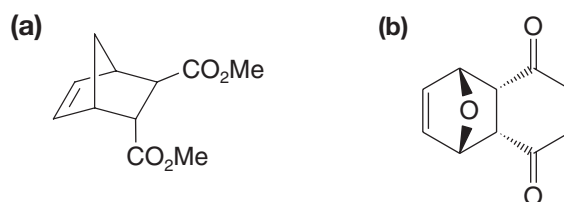

PRACTICE PROBLEM 13.16 Diels–Alder reactions also take place with triple-bonded (acetylenic) dienophiles. Which diene and which dienophile would you use to prepare the following?

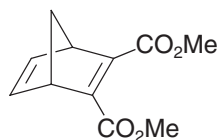

PRACTICE PROBLEM 13.17 1,3-Butadiene and the dienophile shown below were used by A. Eschenmoser in his synthesis of vitamin B₁₂ with R. B. Woodward. Draw the structure of the enantiomeric Diels–Alder adducts that would form in this reaction and the two transition states that lead to them.

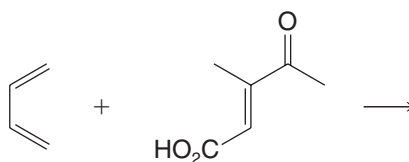



THE CHEMISTRY OF... Molecules with the Nobel Prize in Their Synthetic Lineage

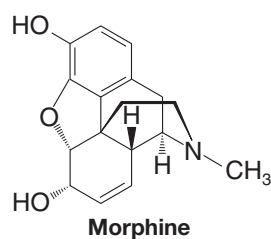
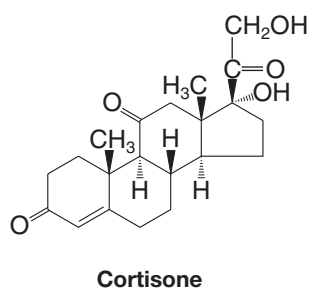

Many organic molecules from among the great targets for synthesis have the Diels–Alder reaction in their synthetic lineage. As we have learned, from acyclic precursors the Diels–Alder reaction can form a six-membered ring, with as many as four new chirality centers created in a single stereospecific step. It also produces a double bond that can be used to introduce other functionalities. The great utility of the Diels–Alder reaction earned Otto Diels and Kurt Alder the Nobel Prize in Chemistry in 1950 for developing the reaction that bears their names.

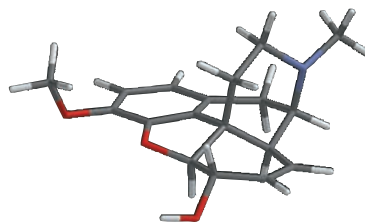
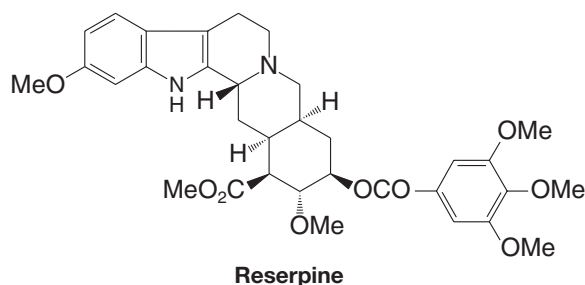

Morphine, the synthesis of which involved the Diels–Alder reaction.

Molecules that have been synthesized using the Diels–Alder reaction (and the chemists who led the work) include morphine (above, and shown as a model), the hypnotic sedative used after many surgical procedures (M. Gates); reserpine (above), a clinically used antihypertensive agent (R. B. Woodward); cholesterol, precursor of all steroids in the body, and cortisone (also above), the antiinflammatory agent (both by R. B. Woodward); prostaglandins $F_{2\alpha}$ and E_2 (Section 13.10C), members of a family of hormones that mediate blood pressure, smooth muscle contraction, and inflammation (E. J. Corey); vitamin B_{12} (Section 7.16A), used in the production of blood and nerve cells (A. Eschenmoser and R. B. Woodward); and Taxol (chemical name paclitaxel, Section 13.10), a potent cancer chemotherapy agent (K. C. Nicolaou). This list alone is a veritable litany of monumental synthetic accomplishments, yet there are many other molecules that have also succumbed to synthesis using the Diels–Alder reaction. It could be said that all of these molecules have a certain sense of “Nobel-ity” in their heritage.

[WHY Do These Topics Matter?

A REACTION THAT COULD HAVE HAD A DIFFERENT NAME

The specific reaction that Otto Diels (the professor) and Kurt Alder (his graduate student) reported in their famous 1928 paper was the merger of two molecules of cyclopentadiene with benzoquinone, as shown below. We have already highlighted the importance and significance of this general reaction process in facilitating the synthesis of complex molecules, something Diels and Alder themselves recognized at the time they made their discovery: “*Thus it appears to us that the possibility of synthesis of complex compounds related to or identical with natural products such as terpenes, sesquiterpenes, perhaps even alkaloids, has been moved to the near prospect.*” In fact, it is because of its broad applicability and utility that this reaction won them the Nobel Prize in 1950.



Associated Press (AP Photo)



Science Source/Photo Researchers, Inc.

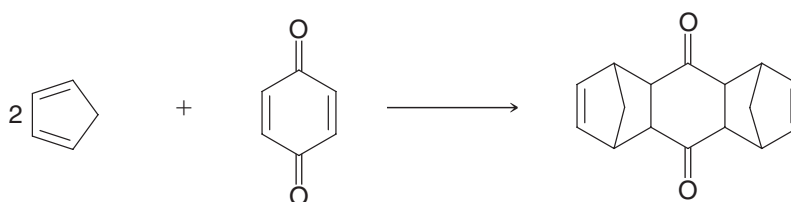

Cyclopentadiene

p-Benzoquinone

(continues on next page)

However, what you may not know is that Diels and Alder were not the first to explore the addition of cyclopentadiene to benzoquinone. Several others, in fact, had performed the same reaction before them. The first was Johannes Thiele and his graduate student Walther Albrecht, who did their work in 1906; based on past experiments, Thiele thought that merger of these two reactants would yield the molecule shown below, while Albrecht believed that it was instead a different addition product. The next exploration of this reaction came from Hermann Staudinger, who, in 1912, proposed a third structure for the product. As we now know, all of these earlier proposals were wrong. Still, it would be difficult to fault these investigators given the absence of spectroscopic tools to aid in structure determination and the fact that reactivity involving a 1,4-cycloaddition was without precedent at the time. Therefore, a major part of the true genius of Diels and Alder lies in the fact that they were the first to recognize just what, in fact, had been formed from the experiment and to suggest that the reaction involved could be a general process.

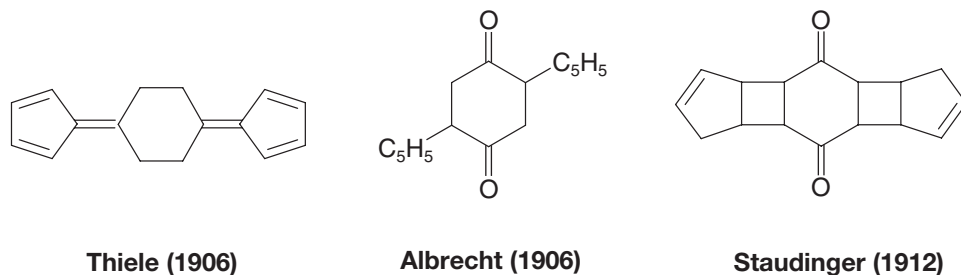

As a final twist to the story, there was yet another professor-and-student team who had run a similar transformation, and correctly predicted a 1,4-cycloaddition product eight years before Diels and Alder. That work was by Hans von Euler and Karl Josephson as shown below. However, they were tentative in their structural assignment, and though they promised to perform a follow-up study to prove their proposal in that paper, for whatever reason that work never appeared. Diels and Alder, by contrast, did much work with the process and expanded it dramatically, hence the reaction bears their names.

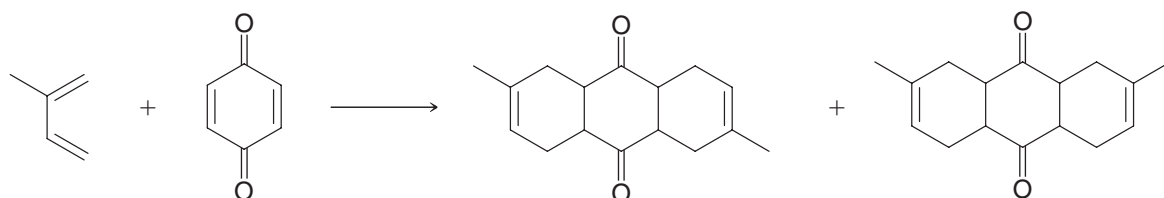

Above structure adapted with permission from Berson, J., *Tetrahedron* 1992, 48, 3–17, Wiley-VCH and Berson, J., *Chemical Creativity: Ideas from the Work of Woodward, Hückel, Meerwein, and Others*, © 1999, Wiley-VCH

To learn more about these topics, see:

1. Berson, J. "Discoveries missed, discoveries made: creativity, influence, and fame in chemistry" in *Tetrahedron* **1992**, 48, 3–17.
2. Berson, J. *Chemical Creativity: Ideas from the Work of Woodward, Hückel, Meerwein, and Others*. Wiley-VCH: Weinheim, **1999**, p.198.

SUMMARY AND REVIEW TOOLS

The study aids for this chapter include key terms and concepts (which are hyperlinked to the Glossary from the bold, blue terms in the *WileyPLUS* version of the book at wileyplus.com) and a Concept Map relating to properties and reactivity of conjugated systems and the Diels–Alder reaction.

PROBLEMS

Note to Instructors: Many of the homework problems are available for assignment via *WileyPLUS*, an online teaching and learning solution.

CONJUGATED SYSTEMS

13.18 Provide the reagents needed to synthesize 1,3-butadiene starting from

(a) 1,4-Dibromobutane

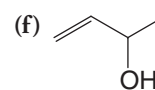
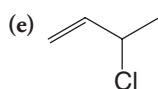
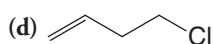
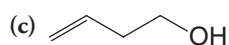
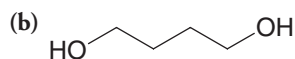

13.19 What product would you expect from the following reaction?

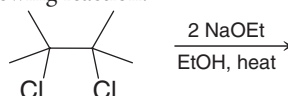



13.20 What products would you expect from the reaction of 1 mol of 1,3-butadiene and each of the following reagents? (If no reaction would occur, you should indicate that as well.)

- (a) 1 mol of Cl_2 (d) 2 mol of H_2 , Ni (f) Hot KMnO_4 (excess)
(b) 2 mol of Cl_2 (e) 1 mol of Cl_2 in H_2O (g) H_2O , cat. H_2SO_4
(c) 2 mol of Br_2

13.21 Provide the reagents necessary to transform 2,3-dimethyl-1,3-butadiene into each of the following compounds.



13.22 Provide the reagents necessary for each of the following transformations. In some cases several steps may be necessary.

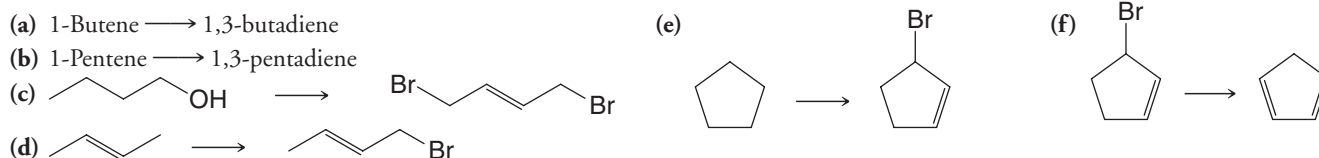

13.23 Conjugated dienes react with radicals by both 1,2- and 1,4-addition. Write a detailed mechanism to account for this fact using the peroxide-promoted addition of one molar equivalent of HBr to 1,3-butadiene as an illustration.

13.24 UV-Vis, IR, NMR, and mass spectrometry are spectroscopic tools we use to obtain structural information about compounds. For each pair of compounds below, describe at least one aspect from each of two spectroscopic methods (UV-Vis, IR, NMR, or mass spectrometry) that would distinguish one compound in a pair from the other.

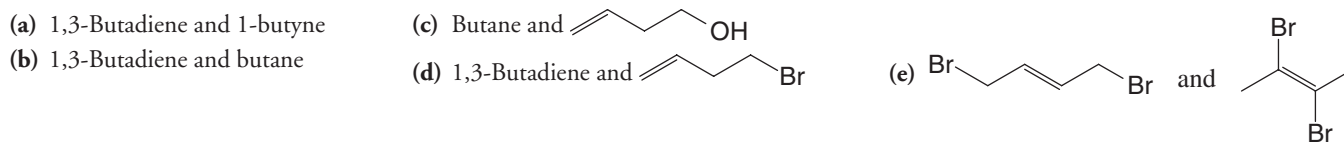

13.25 When 2-methyl-1,3-butadiene (isoprene) undergoes a 1,4-addition of hydrogen chloride, the major product that is formed is 1-chloro-3-methyl-2-butene. Little or no 1-chloro-2-methyl-2-butene is formed. How can you explain this?

13.26 When 1-pentene reacts with *N*-bromosuccinimide (NBS), two products with the formula $\text{C}_5\text{H}_9\text{Br}$ are obtained. What are these products and how are they formed?

13.27 (a) The hydrogen atoms attached to C3 of 1,4-pentadiene are unusually susceptible to abstraction by radicals. How can you account for this? (b) Can you provide an explanation for the fact that the protons attached to C3 of 1,4-pentadiene are more acidic than the methyl hydrogen atoms of propene?

13.28 Provide a mechanism that explains formation of the following products. Include all intermediates, formal charges, and arrows showing electron flow.

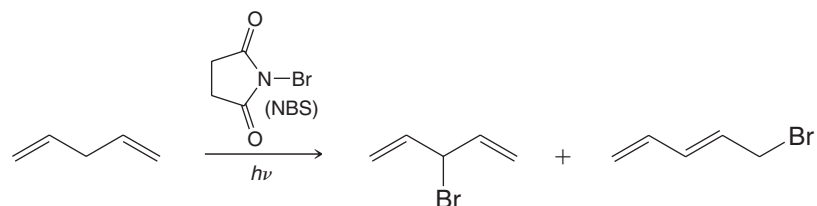

13.29 Provide a mechanism for the following reaction. Draw a reaction energy coordinate diagram that illustrates the kinetic and thermodynamic pathways for this reaction.

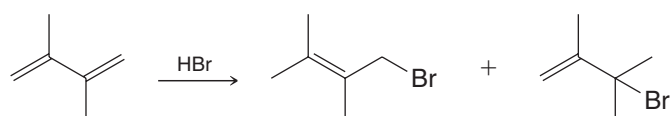

13.30 Predict the products of the following reactions.

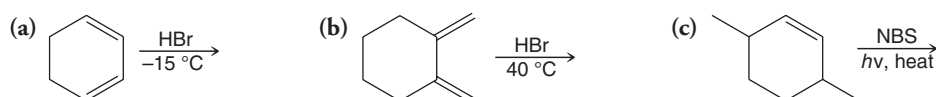

13.31 Provide a mechanism that explains formation of the following products.

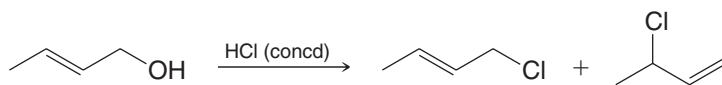

13.32 Provide a mechanism that explains formation of the following products.

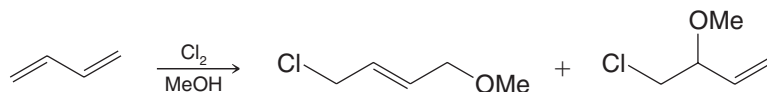

13.33 Treating either 1-chloro-3-methyl-2-butene or 3-chloro-3-methyl-1-butene with Ag_2O in water gives (in addition to AgCl) the following mixture of alcohol products.

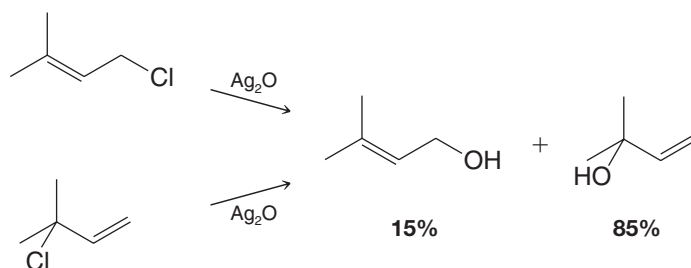

- (a) Write a mechanism that accounts for the formation of these products.
 (b) What might explain the relative proportions of the two alkenes that are formed?

13.34 Dehydrohalogenation of 1,2-dihalides (with the elimination of two molar equivalents of HX) normally leads to an alkyne rather than to a conjugated diene. However, when 1,2-dibromocyclohexane is dehydrohalogenated, 1,3-cyclohexadiene is produced and not cyclohexyne. What factor accounts for this?

13.35 The heat of hydrogenation of allene is 298 kJ mol^{-1} , whereas that of propyne is 290 kJ mol^{-1} . (a) Which compound is more stable? (b) Treating allene with a strong base causes it to isomerize to propyne. Explain.

13.36 Although both 1-bromobutane and 4-bromo-1-butene are primary halides, the latter undergoes elimination more rapidly. How can this behavior be explained?

DIELS-ALDER REACTIONS

13.37 Complete the molecular orbital description for the ground state of cyclopentadiene shown at right. Shade the appropriate lobes to indicate phase signs in each molecular orbital according to increasing energy of the molecular orbitals. Label the HOMO and LUMO orbitals, and place the appropriate number of electrons in each level, using a straight single-barbed arrow to represent each electron.

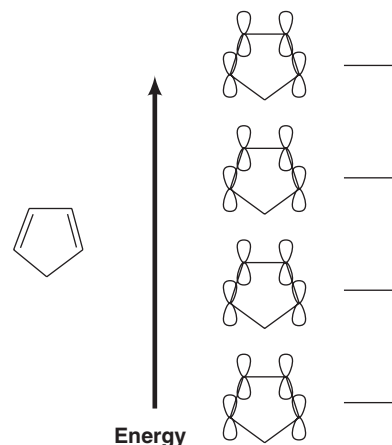

13.38 Why does the molecule shown below, although a conjugated diene, fail to undergo a Diels-Alder reaction?

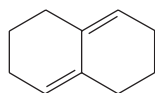

13.39 Rank the following dienes in order of increasing reactivity in a Diels-Alder reaction (1 = least reactive, 4 = most reactive). Briefly explain your ranking.

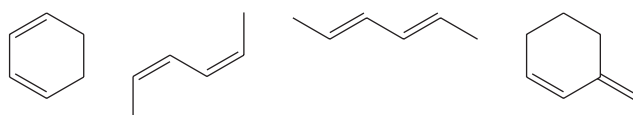



13.40 Give the structures of the products that would be formed when 1,3-butadiene reacts with each of the following:



13.41 Cyclopentadiene undergoes a Diels–Alder reaction with ethene at 160–180°C. Write the structure of the product of this reaction.

13.42 Acetylenic compounds may be used as dienophiles in the Diels–Alder reaction (see Practice Problem 13.16). Write structures for the adducts that you expect from the reaction of 1,3-butadiene with

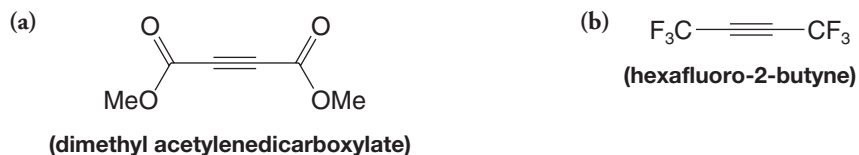

(dimethyl acetylenedicarboxylate)

13.43 Predict the products of the following reactions.

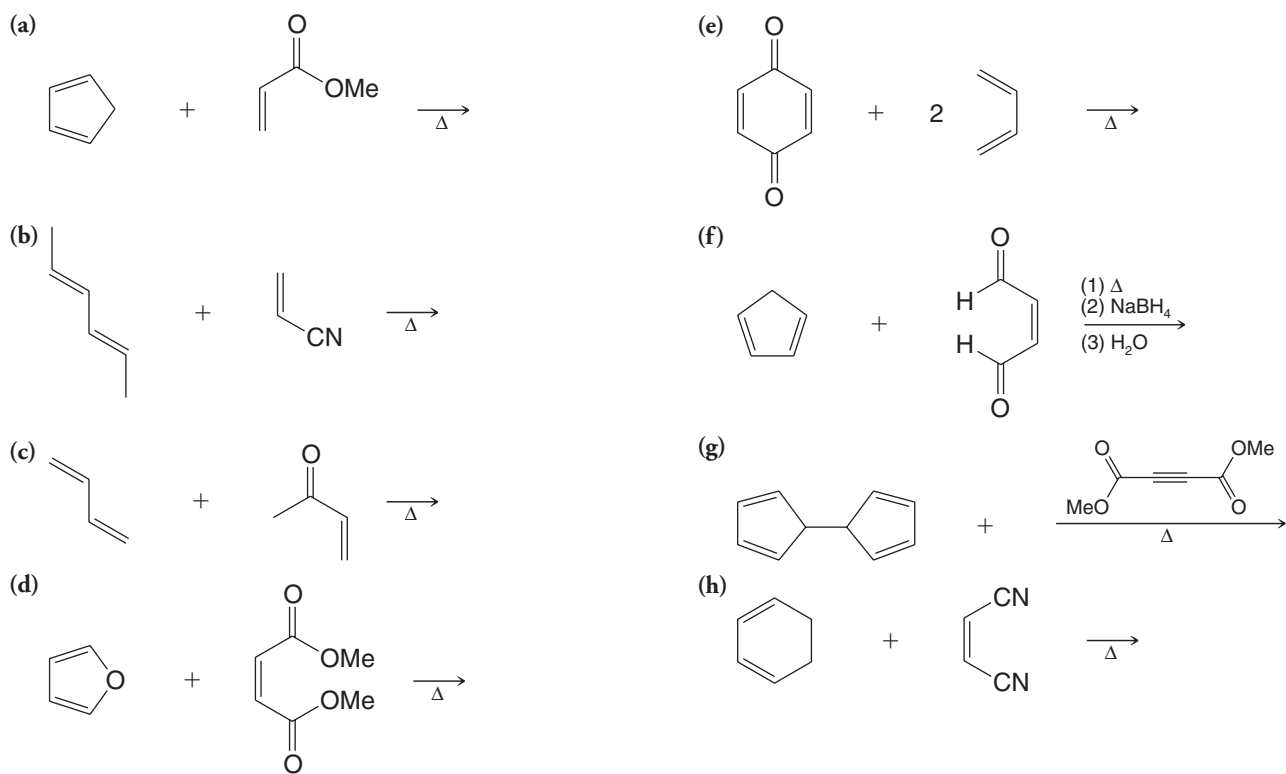

13.44 Which diene and dienophile would you employ in a synthesis of each of the following?

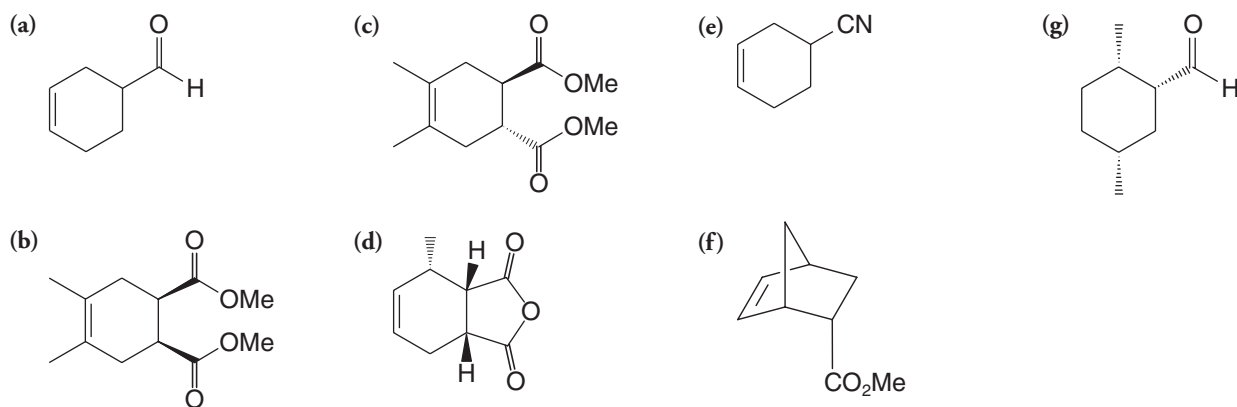

13.45 When furan and maleimide undergo a Diels–Alder reaction at 25°C, the major product is the endo adduct **G**. When the reaction is carried out at 90°C, however, the major product is the exo isomer **H**. The endo adduct isomerizes to the exo adduct when it is heated to 90°C. Propose an explanation that will account for these results.

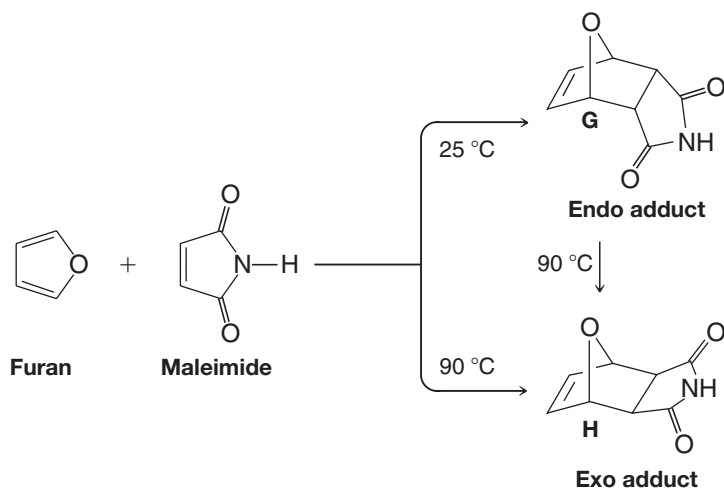

13.46 Two controversial “hard” insecticides are aldrin and dieldrin. [The Environmental Protection Agency (EPA) halted the use of these insecticides because of possible harmful side effects and because they are not biodegradable.] The commercial synthesis of aldrin began with hexachlorocyclopentadiene and norbornadiene. Dieldrin was synthesized from aldrin. Show how these syntheses might have been carried out.

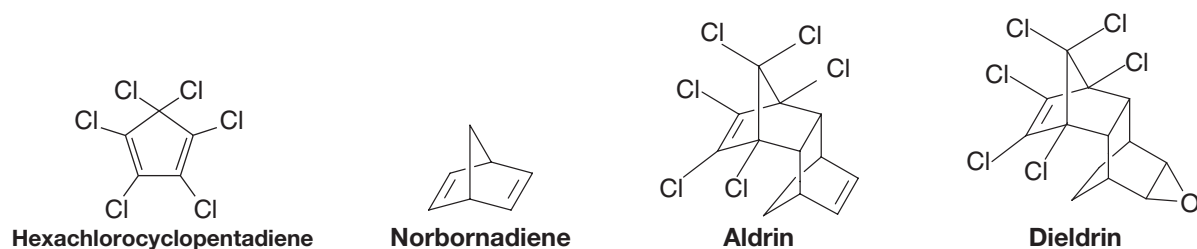

13.47 (a) Norbornadiene for the aldrin synthesis (Problem 13.46) can be prepared from cyclopentadiene and acetylene. Show the reaction involved. (b) It can also be prepared by allowing cyclopentadiene to react with vinyl chloride and treating the product with a base. Outline this synthesis.

13.48 Two other hard insecticides (see Problem 13.46) are chlordan and heptachlor. Show how they could be synthesized from cyclopentadiene and hexachlorocyclopentadiene.

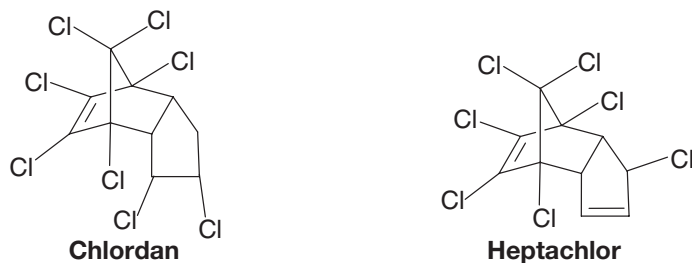

13.49 Isodrin, an isomer of aldrin, is obtained when cyclopentadiene reacts with the hexachloronorbornadiene, shown here. Propose a structure for isodrin.

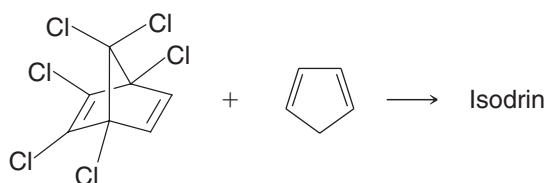



13.50 Provide the reagents necessary to achieve the following synthetic transformations. More than one step may be required.

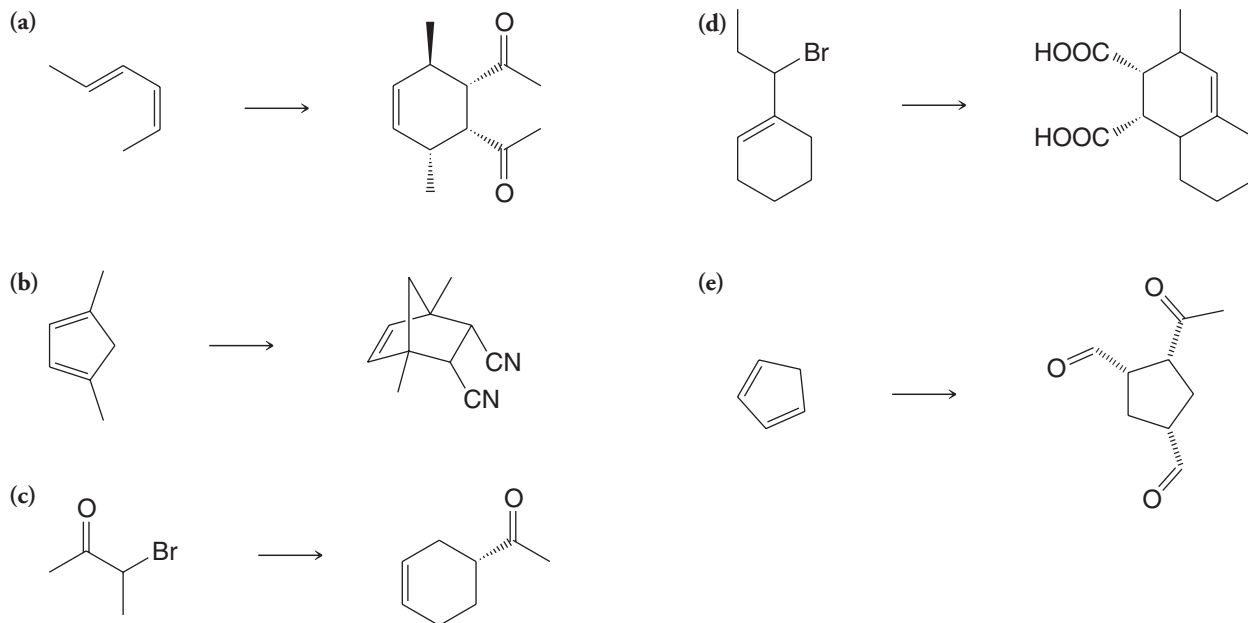

CHALLENGE PROBLEMS

13.51 Explain the product distribution below based on the polarity of the diene and dienophile, as predicted by contributing resonance structures for each.

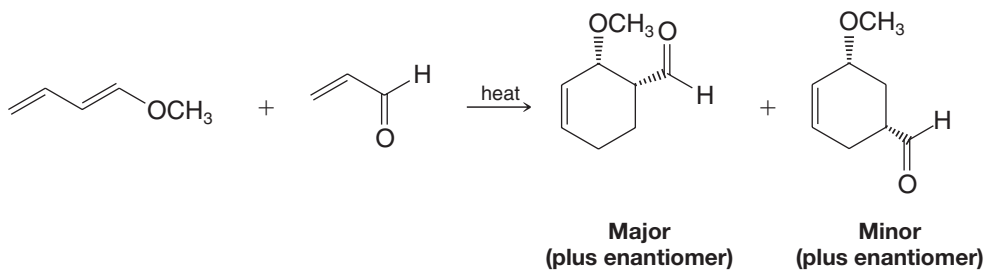

13.52 Mixing furan (Problem 13.45) with maleic anhydride in diethyl ether yields a crystalline solid with a melting point of 125 °C. When melting of this compound takes place, however, one can notice that the melt evolves a gas. If the melt is allowed to resolidify, one finds that it no longer melts at 125 °C but instead it melts at 56 °C. Consult an appropriate chemistry handbook and provide an explanation for what is taking place.

13.53 Draw the structure of the product from the following reaction (formed during a synthesis of one of the endiandric acids by K. C. Nicolaou):

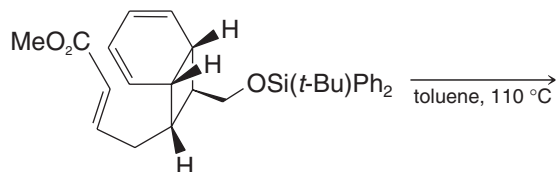

13.54 Draw all of the contributing resonance structures and the resonance hybrid for the carbocation that would result from ionization of bromine from 5-bromo-1,3-pentadiene. Open the computer molecular model at the book's website depicting a map of electrostatic potential for the pentadienyl carbocation. Based on the model, which is the most important contributing resonance structure for this cation? Is this consistent with what you would have predicted based on your knowledge of relative carbocation stabilities? Why or why not?

LEARNING GROUP PROBLEMS

1. Elucidate the structures of compounds **A** through **I** in the following “road map” problem. Specify any missing reagents.

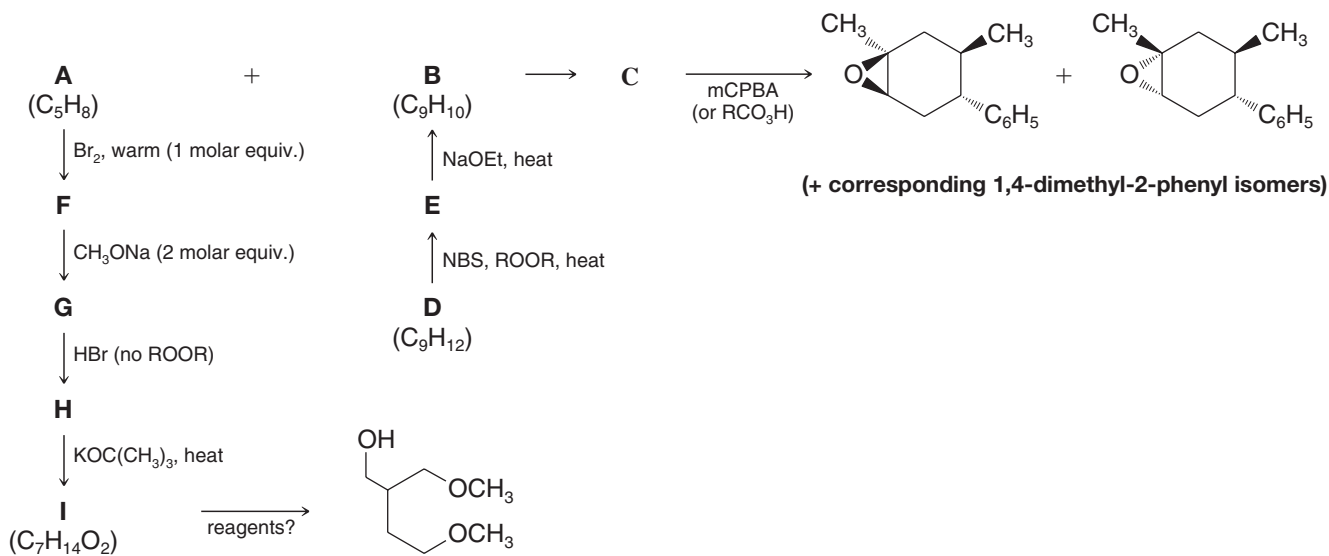

2. (a) Write reactions to show how you could convert 2-methyl-2-butene into 2-methyl-1,3-butadiene.
 (b) Write reactions to show how you could convert ethylbenzene into the following compound:

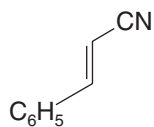

- (c) Write structures for the various Diels–Alder adduct(s) that could result on reaction of 2-methyl-1,3-butadiene with the compound shown in part (b).

[CONCEPT MAP]

